

1. Report No. FHWA/TX-11/0-6112-1		2. Government Accession No.		3. Recipient's Catalog No.	
4. Title and Subtitle DEVELOPMENT OF GUIDELINES FOR TRIPLE LEFT AND DUAL RIGHT-TURN LANES: TECHNICAL REPORT				5. Report Date January 2011 Published: July 2011	
				6. Performing Organization Code	
7. Author(s) Scott A. Cooner, Stephen E. Ranft, Yatin K. Rathod, Yi Qi, Lei Yu, Yubian Wang, and Sammy Chen				8. Performing Organization Report No. Report 0-6112-1	
9. Performing Organization Name and Address Texas Transportation Institute The Texas A&M University System College Station, Texas 77843-3135				10. Work Unit No. (TRAIS)	
				11. Contract or Grant No. Project 0-6112	
12. Sponsoring Agency Name and Address Texas Department of Transportation Research and Technology Implementation Office P. O. Box 5080 Austin, Texas 78763-5080				13. Type of Report and Period Covered Technical Report: September 2008–August 2010	
				14. Sponsoring Agency Code	
15. Supplementary Notes Project performed in cooperation with the Texas Department of Transportation and Federal Highway Administration. Project Title: Development of Guidelines for Triple Left and Dual Right-Turn Lanes URL: <a href="http://tti.tamu.edu/documents/0-6112-1.pdf">http://tti.tamu.edu/documents/0-6112-1.pdf</a>					
16. Abstract Left- or right-turn lanes at intersections improve safety and operations by separating turning and through vehicles. At intersections with heavy turning demand, it may be necessary to provide multiple turn lanes. Triple left-turn (TLT) and dual right-turn (DRT) lanes are still considered as relatively new designs that many agencies are reluctant to use, so they are somewhat limited in Texas. Guidelines for TLT or DRT lanes are almost nonexistent, leaving traffic engineers to rely on judgment for their designs. Therefore, this research was needed to develop consistent guidance. The 0-6112 project achieved two primary project goals: (1) development of geometric and signal design guidelines for TLT and DRT lanes; and (2) evaluation of the safety and operational performance of TLT and DRT sites in Texas.  Researchers conducted field studies at 5 TLT and 20 DRT, primarily in the Dallas-Fort Worth and Houston urban areas, in order to evaluate lane utilization patterns, saturation flow rates, conflicts, and other operational factors. The research team also analyzed safety performance by investigating the crash history of the 25 sites using three techniques: collision diagrams, field conflict study, and comparison study. The results revealed that TLT lanes do not experience any major safety issues and also concluded that, in general, a well-designed DRT lane does not cause significantly higher crash frequency or severity compared to single right-turn lanes.  Based on the results of this research and the geometric and signal design guidelines, TxDOT and other agencies should be confident that well-designed TLT and DRT lanes can be implemented to address heavy turning demand at key intersections. The evaluation of these multiple turn lane sites in Texas revealed that they perform well from both operational and safety standpoints.  TLT and DRT lanes are not appropriate for all situations, and their use should be supported by an operational analysis. Other techniques (grade separation, signal timing, etc.) might be better solutions for a particular site, especially when considering the effects of adjacent intersections, pedestrian/bicycle movements, and other key factors. Researchers developed a product, <i>Keys to Successful Public Outreach</i> , which is useful for implementing multiple turn lane projects.					
17. Key Words Triple, Dual, Left-Turn Lane, Right-Turn Lane, Signal, Intersection Design				18. Distribution Statement No restrictions. This document is available to the public through NTIS: National Technical Information Service Alexandria, Virginia 22312 <a href="http://www.ntis.gov">http://www.ntis.gov</a>	
19. Security Classif.(of this report) Unclassified		20. Security Classif.(of this page) Unclassified		21. No. of Pages 190	22. Price



**DEVELOPMENT OF GUIDELINES FOR  
TRIPLE LEFT AND DUAL RIGHT-TURN LANES:  
TECHNICAL REPORT**

by

Scott A. Cooner, P.E.  
Program Manager/Research Engineer, Texas Transportation Institute

Stephen E. Ranft, E.I.T.  
Assistant Research Specialist, Texas Transportation Institute

Yatin K. Rathod, P.E.  
Associate Transportation Researcher, Texas Transportation Institute

Yi Qi, Ph.D.  
Assistant Professor/Interim Chair, Department of Transportation Studies,  
Texas Southern University

Lei Yu, Ph.D., P.E.  
Professor/Dean, College of Science and Technology, Texas Southern University

Yubian Wang  
Graduate Student, Department of Transportation Studies, Texas Southern University

and

Sammy Chen  
Doctoral Student, Department of Transportation Studies, Texas Southern University

Report 0-6112-1  
Project 0-6112  
Project Title: Development of Guidelines for Triple Left and Dual Right-Turn Lanes

Performed in cooperation with the  
Texas Department of Transportation  
and the  
Federal Highway Administration

January 2011  
Published: July 2011

TEXAS TRANSPORTATION INSTITUTE  
The Texas A&M University System  
College Station, Texas 77843-3135



## **DISCLAIMER**

The contents of this report reflect the views of the authors, who are responsible for the facts and accuracy of the data presented herein. The contents do not necessarily reflect the official views or policies of the Federal Highway Administration (FHWA) and/or Texas Department of Transportation (TxDOT). This report does not constitute a standard or regulation, and is not intended for construction, bidding, or permit purposes. Products mentioned in this report are for informational purposes only and do not imply endorsement by the Texas Transportation Institute (TTI). The engineer in charge of this project was Scott A. Cooner, P.E. #86225 (Texas).

## ACKNOWLEDGMENTS

The activities reported herein were performed by the Texas Transportation Institute (TTI) and Texas Southern University (TSU) as part of a project entitled: *Development of Guidelines for Triple Left and Dual Right-Turn Lanes*, which was sponsored by TxDOT and the FHWA. Mr. Scott A. Cooner, P.E., of the Texas Transportation Institute, served as Research Supervisor, and Mr. Rohit Parikh, P.E., of the Texas Department of Transportation, Fort Worth District, served as the Project Director.

In addition to the project director, the authors acknowledge the following members of the Project Monitoring Committee (PMC), who provided assistance and guidance throughout the project activities:

- Ms. Jane Lundquist, P.E., TxDOT, Design Division – Project Advisor.
- Mr. John Black, P.E., City of Lewisville – Project Advisor.
- Mr. Stuart Corder, P.E., TxDOT, Houston District – Project Advisor.
- Mr. John Gianotti, P.E., TxDOT, San Antonio District – Project Advisor.
- Mr. Mark Mathis, City of Fort Worth – Project Advisor.
- Mr. David Worley, P.E., City of Sugar Land – Project Advisor.
- Mr. Wade Odell, P.E., TxDOT, Research and Technology Implementation Office – Research Engineer.

The authors also appreciate the following important contributions to the research team:

- Mr. Troy Walden and TTI Safety Center student workers for providing and assisting in the analysis of crash data.
- Mr. Tony Voigt and TTI Houston office staff for sharing information regarding the evaluation of a site in Sugar Land, Texas.
- Mr. Frank Espinosa (TxDOT Research and Technology Implementation Office) for his logistical support in organizing project meetings, tracking deliverables, and general support.
- Numerous TxDOT staff that participated in web surveys and provided key performance data on multiple turn-lane sites throughout the state.
- Numerous state and city staff who participated in web surveys and provide key performance data on multiple turn-lane sites throughout the United States.
- Mrs. Christy Harris (TTI) for administrative and editorial support.
- Ms. Diana Wallace (TTI) for data collection supervision and support for the Dallas-Fort Worth area field studies.

# TABLE OF CONTENTS

	<b>Page</b>
List of Figures .....	ix
List of Tables .....	xii
List of Abbreviations .....	xiii
1 INTRODUCTION .....	1-1
1.1 Background and Significance of Research .....	1-1
1.2 Research Work Plan.....	1-2
1.3 Report Organization.....	1-3
2 STATE-OF-THE-PRACTICE LITERATURE REVIEW .....	2-1
2.1 Operational Studies .....	2-1
2.2 Safety Studies.....	2-10
2.3 Existing Warrants and Guidelines .....	2-17
2.4 State-of-the-Practice Summary .....	2-41
2.5 References.....	2-42
3 STATE AND NATIONAL SURVEY OF MULTIPLE TURN LANES .....	3-1
3.1 Survey Design and Distribution.....	3-1
3.2 State Survey Results .....	3-1
3.3 National Survey Results.....	3-9
3.4 Synthesis of Survey Findings.....	3-16
4 FIELD STUDIES .....	4-1
4.1 Field Study Plan.....	4-1
4.2 Selection of Study Sites .....	4-2
4.3 Field Data Collection .....	4-3
4.4 Operational Data Analysis .....	4-7
4.5 Innovative Triple Left-Turn Implementation.....	4-10
4.6 Summary of Field Studies.....	4-12
5 SAFETY PERFORMANCE EVALUATION .....	5-1
5.1 Study Sites and Methodology .....	5-1
5.2 Collision Diagram Safety Performance Analysis .....	5-4
5.3 Field Traffic Conflict Study.....	5-13
5.4 Comparison Study.....	5-19
5.5 Summary of Safety Performance Evaluation.....	5-26
5.6 References.....	5-26

## TABLE OF CONTENTS (Continued)

	<b>Page</b>
6 GEOMETRIC DESIGN GUIDELINES.....	6-1
6.1 Geometric Design Guidelines Framework.....	6-1
6.2 Geometric Design Guidance for Dual Right-Turn Lanes.....	6-1
6.3 Geometric Design Guidance for Triple Left-Turn Lanes.....	6-5
6.4 References.....	6-10
7 SIGNAL DESIGN GUIDELINES.....	7-1
7.1 Signal Design Guidelines Framework.....	7-1
7.2 Signal Design Guidance for Multi-Turn Lanes.....	7-1
7.3 Signal Design Guidance for Dual Right-Turn Lanes.....	7-5
7.4 Signal Design Guidance for Triple Left-Turn Lanes.....	7-13
7.5 References.....	7-15
8 KEY FINDINGS AND RECOMMENDATIONS.....	8-1
8.1 Summary of Key Findings.....	8-1
8.2 Project Recommendations.....	8-2
APPENDIX A: Collision Diagrams for Dual Right-Turn Lanes.....	A-1
APPENDIX B: Collision Diagrams for Triple Left-Turn Lanes.....	B-1
APPENDIX C: Texas Transportation Code 544.007C.....	C-1



## LIST OF FIGURES

Figure	Page
2-1	Shadowed or Unshadowed Triple Left-Turn Lanes ..... 2-5
2-2	Added Crosswalk with Increased Radius ..... 2-8
2-3	Collision Diagram for Intersection SR 969 (NW 72 <sup>nd</sup> Avenue) at NW 12 <sup>th</sup> Street..... 2-12
2-4	Intersection with Storage Areas “Trapped” within a Wide Median Area ..... 2-13
2-5	Shared Right-Turn Lane with No Island, Merge, and No Additional Control ..... 2-14
2-6	Exclusive Right-Turn Lane with No Island, Merge, and No Additional Control. .... 2-14
2-7	Exclusive Right-Turn Lane with Raised Island, Add Lane, and No Additional Control..... 2-14
2-8	Exclusive Right-Turn Lane with Raised Island, Merge, and Yield Control ..... 2-15
2-9	Shared Right-Turn Lane with Raised Island, Large Turning Radius, Merge, and Yield Control..... 2-15
2-10	Summaries of Crashes by Right-Turn Treatment Type ..... 2-16
2-11	Triple Left-Turn Lanes with Downstream Lane Drop ..... 2-19
2-12	Types of Triple Left-Turn Lanes Configuration ..... 2-21
2-13	Average Delay vs. Left-Turn Volume for Development of Left-Turn Volume-Based Warrants..... 2-23
2-14	Two Problems in Left-Turn Operations ..... 2-24
2-15	Types of Treatments for Right-Turn Movements ..... 2-29
2-16	Warrants for Right-Turn Treatments on Two-Lane Highways..... 2-30
2-17	Warrants for Right-Turn Treatments on Four-Lane Highways..... 2-31
2-18	Warrants for Right-Turn Lanes ..... 2-33
2-19	Typical State Design Manual Guideline for Right-Turn Lanes at Unsignalized Intersections on Two-Lane Highways..... 2-35
2-20	Right-Turn Lane and Right Turning Roadway Examples..... 2-37
2-21	Details of Corner Island Designs for Turning Roadways (Urban Locations)..... 2-39
3-1	Three Types of Triple Left-Turn Implementation..... 3-2
3-2	Design Criteria for Triple Left-Turn Installations (State Survey)..... 3-2
3-3	Installation Criteria for Triple Left-Turn Installations (State Survey)..... 3-3
3-4	Design and Operational Issues for Triple Left-Turn Installations (State Survey)..... 3-3
3-5	Three Types of Dual Right-Turn Implementation. .... 3-5
3-6	Design Criteria for Dual Right-Turn Installations (State Survey). .... 3-6
3-7	Installation Criteria for Dual Right-Turn Installations (State Survey)..... 3-7
3-8	Design and Operational Issues for Dual Right-Turn Installations (State Survey). .... 3-8
3-9	Design Criteria for Triple Left-Turn Installations (National Survey)..... 3-10
3-10	Installation Criteria for Triple Left-Turn Installations (National Survey).... 3-11
3-11	Design and Operational Issues for Triple Left-Turn Installations (National Survey).... 3-11
3-12	Design Criteria for Dual Right-Turn Installations (National Survey)..... 3-13
3-13	Installation Criteria for Dual Right-Turn Installations (National Survey)..... 3-14
3-14	Design and Operational Issues for Dual Right-Turn Installations (National Survey) .... 3-15
4-1	Example of Autoscope Van In-Field Setup..... 4-4

## LIST OF FIGURES (Continued)

Figure	Page
4-2 Intersection Layout with Lane Widths – West Bay Area Blvd at IH-45 .....	4-4
4-3 Advanced Traffic Sign – Southbound Gerault Road Approach.....	4-5
4-4 Pavement Markers at FM 2499 at Gerault Road Intersection .....	4-5
4-5 Lane Numbering Convention Used in Research Report .....	4-6
4-6 Lane Utilization for Dual Right-Turn Lane Sites (DFW Area) .....	4-8
4-7 Lane Utilization for Dual Right-Turn Lane Sites (Houston Area).....	4-9
4-8 Lane Utilization for Triple Left-Turn Lane Sites .....	4-9
4-9 Triple Left-Turn LPM System in Sugar Land, Texas (Daytime).....	4-11
4-10 Triple Left-Turn LPM System in Sugar Land, Texas (Nighttime) .....	4-11
5-1 Crash Map in Houston.....	5-3
5-2 Identification Process of Crashes Related to Study Intersections .....	5-3
5-3 Rear-End Crash Hot Spots at Six Flags Drive at SH 360 .....	5-7
5-4 Rear-End Crash Hot Spots at AT&T Center Parkway at IH-35.....	5-8
5-5 Rear-End Crash Hot Spots at Kirby Drive at IH-610.....	5-8
5-6 Illustration of Short Deceleration Distance as a Contributor to Rear-End Crashes (Babcock Road at WB IH-410, San Antonio).....	5-9
5-7 Lane Configurations for the Dual Right-Turn Lanes .....	5-10
5-8 Main Street at IH-35E .....	5-10
5-9 Sherwin Street at Washington Avenue.....	5-11
5-10 Illustration of Heavy Vehicle as a Cause of Angle Crashes.....	5-11
5-11 Illustration of Unclear or Confusing Turning Guide Lines as a Contributor to Angle Crashes (Main Street at SB DNT) .....	5-12
5-12 Illustration of Unclear or Confusing Turning Guide Lines as a Contributor to Angle Crashes (Legacy Drive at NB DNT) .....	5-12
5-13 Illustration of Cross-Movement Conflicts.....	5-14
5-14 Triple Left-Turn Lanes on Westcott Street at Memorial Drive.....	5-15
5-15 Dual Right-Turn Lanes with Significant Numbers of Cross-Movements (Saturn Lane at NASA Parkway) .....	5-18
5-16 Illustration of Lane Blockage .....	5-19
6-1 Dual Right-Turn with Bicycle Lane .....	6-3
6-2 General Triple Left-Turn Lane Delineation .....	6-7
6-3 Triple Left-Turn Lane Configurations .....	6-8
7-1 Lateral and Longitudinal Locations of Primary Signal Faces .....	7-2
7-2 Advance Overhead Sign for Dual Right-Turn Lane .....	7-4
7-3 Supplemental Signs with Downstream Lane Configurations.....	7-5
7-4 Typical Positions of Shared Signal Faces for Protected Only Mode Right Turns .....	7-6
7-5 Signal Indications for Approaches with a Shared Left-Turn/Right-Turn Lane and No Through Movement or Conflicting Vehicular or Pedestrian Movements.....	7-6
7-6 Signal Indications for Approaches with a Shared Left-Turn/Right-Turn Lane and No Through Movement with Pedestrian or Vehicular Conflicts.....	7-7
7-7 Saturn Lane at NASA Parkway .....	7-8

## LIST OF FIGURES (Continued)

Figure	Page
7-8 Dual Right-Turn Lanes with an Entrance Ramp at the Nearby Cross-Street Downstream Location .....	7-9
7-9 Precinct Line at SH 183 Dual Right-Turn Lane Signs and Markings.....	7-10
7-10 Forest Lane at IH-635.....	7-11
7-11 No Turn on Red Sign R10-11d.....	7-12
7-12 Other Sign Options for Prohibiting Right-Turn on Red Movements.....	7-12
7-13 Blank-Out Signs Used to Control Right-Turn Movements by Time of Day .....	7-13
7-14 Separation between Concurrent Opposing Left-Turns.....	7-14

## LIST OF TABLES

Table	Page
2-1 Summary of Operational Studies on Triple Left-Turn Lanes .....	2-9
2-2 Summary of Operational Studies on Right-Turn Lanes .....	2-10
2-3 Minimum Merging Section Lengths for Triple Left-Turn Lanes .....	2-20
2-4 Guidelines for Determining the Minimum Required Merging Section Length .....	2-26
2-5 Length of Dual Left-Turn or Right-Turn Lanes on Urban Streets .....	2-26
2-6 Summary of Existing Warrants for Triple Left-Turn Lanes .....	2-27
2-7 Summary of Existing Guidelines for Triple Left-Turn Lanes .....	2-27
2-8 Minimum Right-Turn Directional Design Hour Volumes (DDHV) Required to Warrant Right-Turn Treatments for Two-Lane Highways .....	2-34
2-9 Minimum Right-Turn Directional Design Hour Volumes (DDHV) Required to Warrant Right-Turn Treatments for Four-Lane Highways .....	2-34
2-10 Right-Turn Lane Designs .....	2-35
2-11 Warrants for Right-Turn Lanes Used by State DOTs .....	2-40
2-12 Summary of Existing Warrants for Right-Turn Lanes .....	2-41
3-1 Summary of Survey Results .....	3-16
4-1 Triple Left-Turn Sites for Field Data Collection .....	4-2
4-2 Dual Right-Turn Sites for Field Data Collection .....	4-3
4-3 Static Data Summary for Dual Right-Turn Intersections .....	4-7
4-4 Static Data Summary for Triple Left-Turn Intersections .....	4-7
4-5 Average Saturation Flow for Triple Left-Turn and Dual Right-Turn Sites .....	4-10
5-1 Study Sites for Collision Diagrams-Based Study and Comparison Study .....	5-1
5-2 Study Sites for Field Traffic Conflict Study .....	5-2
5-3 Dual Right and Triple Left-Turn Related Crashes (Six-Year Counts: 2003-2008) .....	5-5
5-4 Intersection Geometric Conditions (Dual Right-Turn Lanes) .....	5-6
5-5 Traffic Conflict Counts in the Field Studies .....	5-14
5-6 Characteristics of the Field Traffic Conflict Study Locations .....	5-16
5-7 Severity of Crashes at Dual Right-Turn Lanes (20 Locations, 6-Year Period) .....	5-21
5-8 Severity of Crashes at Triple Left-Turn Lanes (5 Locations, 6-Year Period) .....	5-21
5-9 Frequency of Crashes at Dual Right-Turn Lanes (20 Locations, 6-Year Period) .....	5-22
5-10 Frequency of Crashes at Triple Left-Turn Lanes (5 Locations, 6-Year Period) .....	5-22
5-11 Implementation of Study Intersections in Houston .....	5-22
5-12 Number of Crashes Before and After Dual Right-Turn Implementation in Houston .....	5-22
5-13 Crash Counts for Each Six-Month Period .....	5-23
5-14 Overall Crash Experience of Dual Right-Turn Lanes and Comparative Single Right-Turn Lanes .....	5-24
5-15 Overall Crash Experience of Dual Right-Turn Lanes and Comparative Single Right-Turn Lanes (Part II) .....	5-25
8-1 Basic Guidance Framework for Outreach for Multiple Turn Lane Facilities .....	8-3

## LIST OF ABBREVIATIONS

AASHTO	American Association of State Highway and Transportation Officials
AADT	Annual Average Daily Traffic
ANOVA	Analysis of Variance
AVE	Avenue
BLVD	Boulevard
CRIS	Crash Records Information System
DDHV	Directional Design Hour Volume
DFW	Dallas-Fort Worth
DHV	Design Hour Volume
DNT	Dallas North Tollway
DR	Drive
DRT	Dual Right-Turn
DOT	Department of Transportation
E	East
EB	Eastbound
EIT	Engineer-in-Training
FHWA	Federal Highway Administration
FM	Farm-to-Market
FR	Frontage Road
HCM	Highway Capacity Manual
HCS	Highway Capacity Software
HGAC	Houston-Galveston Area Council
IH	Interstate Highway
ITE	Institute of Transportation Engineers
LN	Lane
LPM	Lighted Pavement Marker
LT	Left-Turn
MCB	Multiple Comparison with the Best
MOE	Measure of Effectiveness
MPH	Miles per Hour
MUTCD	Manual on Uniform Traffic Control Devices
N	North
NASA	National Aeronautics and Space Administration
NB	Northbound
NCHRP	National Highway Cooperative Research Program
PCPHPL	Passenger Cars per Hour per Lane
PCPHGPL	Passenger Cars per Hour Green per Lane
PE	Professional Engineer
PGBT	President George Bush Turnpike
PKWY	Parkway
PMC	Project Monitoring Committee
PPLT	Protected-Permissive Left Turn

## LIST OF ABBREVIATIONS (Continued)

RD	Road
RMC	Research Management Committee
ROW	Right-of-Way
RPM	Raised Pavement Marker
RT	Right-Turn
RTOR	Right-Turn-on-Red
SB	Southbound
SH	State Highway
SPSS	Statistical Package for the Social Sciences
S	South
ST	Street
SU	Single Unit
TLT	Triple Left-Turn
TRB	Transportation Research Board
TSU	Texas Southern University
TTC	Texas Transportation Code
TTI	Texas Transportation Institute
TxDOT	Texas Department of Transportation
US	United States
VPH	Vehicles per Hour
VPHPL	Vehicles per Hour per Lane
VPHGPL	Vehicles per Hour Green per Lane
W	West
WB	Westbound

# CHAPTER 1

## INTRODUCTION

### 1.1 BACKGROUND AND SIGNIFICANCE OF RESEARCH

Left-turn or right-turn lanes are provided at intersections for improving the intersection safety and operations by separating turning vehicles from through vehicles. At intersections with heavy turning movements, it may be necessary to consider providing multiple turn lanes to accommodate the increasing turning demand volumes. Dual left-turn lanes are commonly used for this purpose. Triple left-turn lanes and dual right-turn lanes are still considered as relatively new design alternatives that many agencies are reluctant to approve. These designs have been implemented in a very limited number of intersections in Texas. The guidelines to implement triple left-turn lanes or dual right-turn lanes are almost nonexistent, leaving traffic engineers to rely on engineering judgment for their design. Therefore, research is needed to develop consistent design and operational procedures for both triple left-turn and dual right-turn lanes.

This research developed geometric design and installation guidelines for triple left-turn and dual right-turn lane sites. It also investigated the current usage of triple left-turn and dual right-turn lanes in Texas from operational, safety, and design perspectives, and developed guidance based on these findings. The research team designed the project work plan to answer the following questions:

- When should triple left-turn lanes or dual right-turn lanes be provided?
- What should be considered in the design of triple left-turn or dual right-turn lanes?
- How do you operate intersections with triple left-turn or dual right-turn lanes to make them work efficiently and safely?

To develop a full context for these questions, researchers reviewed the following four topics associated with the design and operation of triple left-turn and dual right-turn lanes:

- Existing warrants and guidelines.
- Geometric design issues.
- Operational characteristics.
- Safety impacts.

Overall, the existing guidelines on the design and operation of triple left-turn lanes and dual right-turn lanes are very limited. There is a lack of detailed and quantitative guidelines for these new design options. For example, the qualitative criteria for throat width and turning guide line width are only available for dual left-turn lanes, but not for triple left-turn lanes. In addition, safety is still a major concern for many traffic engineers to implement these new design options. Thus, research is needed to fully understand the safety impacts of these multiple turn lanes and to develop more detailed and easy-to-use design guidelines for field implementation purposes.

## 1.2 RESEARCH WORK PLAN

In light of the context provided in the above background of research, project 0-6112 is intended to achieve two goals: (1) develop geometric design and installation guidelines for triple left-turn and dual right-turn lanes, and (2) evaluate the safety and operational performances of existing triple left-turn and dual right-turn lane sites in Texas. To this end, the research will employ the following specific objectives:

- Review existing design guidelines and practices regarding triple left-turn lanes and dual right-turn lanes around the country.
- Perform studies of existing triple left-turn and dual right-turn locations to document existing design issues and concerns, operational performance, and safety performance (both vehicle and pedestrian).
- Identify important factors that affect the design, operation, and safety of triple left-turn and dual right-turn lanes.
- Develop geometric design criteria for triple left-turn and dual right-turn lanes, such as the throat width, dotted line lane width, departure lane widths, storage bay and taper lengths.
- Develop installation criteria for determining when triple left-turn or dual right-turn lanes should be installed.
- Develop guidance on the signal design for installation of triple left-turn or dual right-turn lanes.

The research utilized a work plan, consisting of the following 12 tasks, to accomplish the objectives:

- Task 1- Develop Project Website (<http://www.turnlanes.net/>).
- Task 2- Perform State-of-the-Practice Literature Review.
- Task 3- Conduct National Survey.
- Task 4- Conduct Statewide Survey.
- Task 5- Develop Plan for Field Studies.
- Task 6- Collect Field Data.
- Task 7- Analyze the Design and Operational Characteristics of the Study Sites.
- Task 8- Assess the Safety Performance of the Study Sites.
- Task 9- Develop Geometric Design Guidelines for Triple Left-Turn and Dual Right-Turn Lanes.
- Task 10- Develop Guidance on the Signal Design for Installation of Triple Left-Turn or Dual Right-Turn Lanes.
- Task 11- Develop Public Education and Information Materials.
- Task 12- Document Research Findings.



### **1.3 REPORT ORGANIZATION**

The focus of report 0-6112-1 is to document all of the research activities performed during the project. Chapter 1 (Introduction) provides the reader with an overview of the report and how it is organized.

Chapter 2 (State-of-the-Practice Literature Review) summarizes the state-of-the-practice literature review on the design and operation of triple left-turn lanes and dual right-turn lanes. The research team utilized several methods, including transportation research databases and internet searches.

Chapter 3 (State and National Survey of Multiple Turn Lanes) describes the results of a state and national survey on multiple turn lane design and operation. Researchers developed a 22-question survey instrument that was designed to gather key information about the design and operations of triple left-turn and dual right-turn lanes around the country.

Chapter 4 (Field Studies) contains a detailed description of the study methodology and results from field studies at triple left-turn and dual right-turn lane sites in Texas. The research team conducted analysis of operational data, including traffic volumes, saturation flow rates, and conflicts, in order to assess the multiple turn lane performance.

Chapter 5 (Safety Performance Evaluation) includes a description of the site selection methodology and results from a safety evaluation of triple left-turn and dual right-turn lane sites in Texas. Researchers evaluated safety performance by investigating the crash history of the 25 sites using three techniques: collision diagrams, field conflict study, and comparison study.

Chapter 6 (Geometric Design Guidelines) outlines the geometric design guidelines for assisting in the decision process related to dual right and triple left-turn projects. The research team based the guidance on the results of the state-of-the-practice literature review, the web-based survey of transportation professionals, and the operational and safety performance assessment of Texas sites.

Chapter 7 (Signal Design Guidelines) explains the specific issues and concerns related to traffic signal design and operations associated with triple left-turn and dual right-turn lanes. As with the geometric design guidance, researchers also used the results from previous tasks to develop the recommended guidance.

Chapter 8 (Key Findings and Recommendations) summarizes the key findings, conclusions, and recommendations of the research team based on the study of triple left and dual right-turn lanes in Texas.



## CHAPTER 2 STATE-OF-THE-PRACTICE LITERATURE REVIEW

Left-turn or right-turn lanes are provided at intersections for improving the intersection safety and operations by separating turning vehicles from through vehicles. At intersections with heavy turning movements, it may be necessary to consider providing multiple turn lanes to accommodate the increasing turning demand. The objective of this research is to develop consistent design and operational guidelines for both triple left-turn (TLT) and dual right-turn (DRT) lanes. For this purpose, the research team focused the state-of-the-practice literature review on the following three areas associated with the design and operation of TLT and DRT lanes:

- Operational studies.
- Safety studies.
- Existing warrants and guidelines.

It is important to note that, since existing studies/guidelines on DRT lanes are very limited, researchers reviewed studies/guidelines on single right-turn lanes instead.

### 2.1 OPERATIONAL STUDIES

#### Triple Left-Turn Lanes

The research team found that existing operational studies on TLT lanes focused on the operational efficiency, with emphasis on saturation flow rates and lane utilization. The following subsections briefly summarize six of the most significant studies on the topic of TLT operations.

##### *Leonard (1994)*

In this study, in order to determine the operational characteristics of TLT lanes, Leonard first calculated the saturation flow rates of each TLT lane at five studied intersections based on the data manually collected using an electronic counting board. After that, Leonard investigated the impacts of the influencing factors, such as site location, lane location, time of day, and day of week, on the saturation flow rates of triple left-turn lanes using a statistical method called Analysis of Variance (ANOVA). Leonard's major findings included:

- Saturation flow rates: The average saturation flow rates for the inner, middle, and outer lanes are 1,946 vphgpl (vehicles per hour of green per lane), 1,950 vphgpl, and 1,891 vphgpl, respectively. The average saturation flow for the five intersections with TLT lanes was 1,930 vphgpl, which is much larger than the ideal saturation flow rate of 1,800 vphgpl suggested by the *Highway Capacity Manual* (HCM, 1994).
- Overall impacts of site location, lane location, time of day, and day of week: Leonard found no significant differences in saturation flow rates for different sites during different weekdays (e.g., Monday through Friday). However, he did find significant differences between lanes (e.g., inner and middle versus outer), time of day (morning, midday, and afternoon), and time of week (weekday versus weekend).

- Impacts of lane location: Leonard found a significant difference between the saturation flow rates of different lanes at the TLT lane sites. It was found that the outer lane (with an observed mean saturation flow rate of 1,891 vphgpl) exhibits reduced saturation flow rates from the inner and middle lanes (with an observed mean saturation flow rate of 1,946 vphgpl and 1,950 vphgpl). In addition, there is also a significant difference in the utilization of different lanes. It was found that the lane utilization factors for the inner/middle lane group is 1.01, and for the outer lane group is 0.98. Note that the lane utilization factors were calculated by Equation (1):

$$fLU = Vg / (Vg1 * N) \quad (1)$$

Where:

Vg = the unadjusted demand flow for the lane group in vehicles per hour.

Vg1 = the unadjusted demand flow on a single lane in the lane group with the highest volume in vehicles per hour.

N = the number of lanes in the lane group.

- Impacts of time of day: Leonard verified a significant difference between the saturation flow rates of different time periods of day and determined:
  - The average saturation flow rate during a.m. peak period is 1,990 vphgpl.
  - The average saturation flow rate during the midday period is 1,860 vphgpl.
  - The average saturation flow rate during p.m. peak period is 1,920 vphgpl.

Leonard asserted that this impact may be due to the difference in the population of drivers where drivers can be classified into two subpopulations: commuting and non-commuting. He indicated that the commuting drivers tended to be more aggressive and accepted smaller headways, and that the driver population in these three periods had the following features:

- The a.m. peak period consists of primarily commuter drivers.
- The midday period consists of primarily non-commuting drivers.
- The p.m. peak consists of a mix of commuting and non-commuting drivers.

As a result, Leonard found that the saturation flow rate during the p.m. period is approximately the midpoint of those in the a.m. and midday periods.

- Impacts of day of week: Leonard established that the average saturation flow rate during the weekend is significantly less than that during the weekdays. He found that the observed average saturation flow rate during the weekend is 1,810 vphgpl and that during the weekdays is 1,940 vphgpl. He asserted that it may also be due to a difference in the population of drivers. In the weekday, commuter drivers count a big portion of the driver population while in the weekend most of the drivers are non-commuter drivers.
- Lane utilization: According to the field observations, Leonard found that there are more chances to observe queues in the inner and middle lanes than in the outer lane, which indicates that vehicles prefer the inner and middle lanes to the outer lane.

### ***ITE Technical Council Committees 5P-5 and 5P-1 (1995)***

The Institute of Transportation Engineers (ITE) Technical Council Committee 5P-1 conducted a study at 17 TLT lane intersections in seven states to investigate the saturation flow rates of triple left-turn lanes. The results of this ITE study revealed the following key findings:

- ***Saturation flow rates:*** An overall average saturation flow rate for these 17 TLT lane intersections is approximately 1,830 passenger cars per hour green per lane (pcphgpl). This saturation flow rate is within about 5 percent of the rates Leonard reported.
- ***Impacts of lane location:*** There is no significant difference in the saturation flow rates between each of the three turn lanes, or between the turn lanes and the adjacent through lane. This result suggested that a left-turn adjustment factor ( $f_{LT}$ ) of 1.00 may be appropriate for triple left-turn lanes. Note that the left-turn adjustment factor,  $f_{LT}$ , is defined by Equation (2):

$$f_{LT} = S_{LT} / S_{TH} \quad (2)$$

Where:

$S_{LT}$  = the average saturation flow rate of the three left-turn lanes.

$S_{TH}$  = the saturation flow rate of the adjacent through lane.

### ***Ackeret (1996)***

Ackeret conducted a field study at 23 intersections with single left-turn lanes, 36 intersections with double left-turn lanes, and three intersections with TLT lanes in the Las Vegas metropolitan area. In this study, Ackeret calculated the saturation flow rates for both left-turn lanes and their adjacent through lanes based on the saturation headways measured between the 4<sup>th</sup> and 8<sup>th</sup> vehicles in a queue. The major results of this Ackeret study are:

- ***Saturation flow rates:*** For TLT lanes, the average saturation flow rates for the outside, middle, and inside left-turn lanes are 1,825 pcphpl, 1,809 pcphpl, and 1,773 pcphpl, respectively. Ackeret found that the studied TLT intersections in Las Vegas had lower saturation flow rates than the intersections Leonard studied in Orange County, California.
- ***Left-turn adjustment factor  $f_{LT}$  [see Equation (2)]:*** The average  $f_{LT}$  in this study is 0.95, which is the same as what the HCM recommended.

### ***Courage et al. (2002)***

The authors conducted four different studies to investigate the operational characteristic of TLT lanes at seven intersections in South Florida. The research team provides a brief description of these studies in the following list:

- ***Saturation flow rates:*** The authors calculated the combined saturation flow rate for each study intersection to determine whether there were any conspicuous patterns among these sites. The results showed that the “combined saturation flow rate” (per lane) at these TLT lane locations are within the range of 1,544 to 2,150 pcphgpl, and that intersections with similar geometric characteristics yielded very similar saturation flow rates.
- ***Impacts of lane location:*** The authors calculated the average weighted volume per cycle (with trucks treated as equivalent to two passenger cars) for each left-turn lane at each study intersection to determine whether there were any lane preferences. The results showed that there is little evidence on general preferences for one lane over others.

- Impacts of time of day: The authors chose a special site, which is a Y-intersection and only allows left-turn movement, and compared the weighted volumes per cycle (with trucks treated as equivalent to two passenger cars) during different time periods of day of these three left-turn lanes. The results showed that the difference between lanes at this intersection was also marginal, but the difference with the time of day was profound.
- Impacts of trucks: The authors compared the standard deviations of vehicle headways in the periods with and without the presence of trucks to determine the impacts of trucks on TLT lane operations. The results showed that the presence of trucks, compared to autos alone, introduces a significant degree of increased variability in headway, and trucks in the inner lane had the greatest effect.

### ***Sando and Mussa (2003)***

Sando and Mussa conducted five different studies to analyze the influence of a number of geometric factors on the operation of TLT lanes. They conducted these studies at 15 intersections with TLT lanes in Florida and investigated the following operational issues: saturation flow rate, lane usage, and lane utilization. The results of the Sando and Mussa study revealed the following key findings:

- Saturation flow rate: The authors collected data about the intersection saturation headway using an electronic turning-movement counter. Then, the saturation flow rates for each left-turn lane at each intersection during different time periods were calculated based on the collected headway data. The results of this study showed that the average saturation flow rates for the outer, middle, and inner left-turn lanes are 1,858 pcphgpl, 1,867 pcphgpl, and 1,852 pcphgpl, respectively. The overall average saturation flow rate for these 15 intersections with triple left-turn lanes is 1,859 pcphgpl; there is no significant difference in the saturation flow rates between the outer, middle, and inner left-turn lanes. There was also no significant difference in saturation flow rates during three different time periods (morning peak-hour, midday, and evening peak-hour).
- Impacts of geometric factors on saturation flow rates: The authors analyzed the influence of the various geometric factors, including intersection types (T-type or 4-leg), skew (right angle or skewed), street type (one-way or two-way), approach grade (slope or level), shadowed (with or without storage bay), presence of railroad crossings, and approach type (curved or not), on the saturation flow rates by using the ANOVA statistic method. The results showed that the intersection type, shadowing effect, and presence of railway crossing have no significant impacts on the saturation flow rates of triple left-turn lanes. On the other hand, the intersection skew, street type, approach grade, and approach type have significant impacts on the saturation flow rates. After that, the authors also investigated the factors that have the most significant impacts on the saturation flow rates by using Hsu's multiple comparison with the best (MCB) test. Sando and Mussa found that downgrade slope and skews are the two factors that most contribute to the high saturation flow rates, whereas one-way streets and curved approaches appear to be the two factors that most contribute to the low saturation flow rates.
- Left-turn factor: Equation (2) estimated the left-turn factor in this study by based on the collected saturation flow rates. The estimated left-turn factor is 0.915, which is lower than the values the ITE Technical Council, Ackeret, and the HCM have reported.
- Lane utilization: Sando and Mussa estimated the lane utilization factor in this study by Equation (1) based on the collected saturation flow rates. The estimated lane utilization

factor is 0.88, which indicates the unequal lane utilization of the TLT lanes as a lane group.

- Impacts of geometric configurations on lane utilization: This study analyzed the influences of geometric configurations, including shadowed or unshadowed (see Figure 2-1), length of storage bay, and lane utilization at the TLT lane sites. The results showed that the innermost lanes of the shadowed intersections are less utilized as compared with the innermost lanes of the unshadowed intersections, and the longer the storage bays of the shadowed lanes are, the higher the lane usage rate of the innermost lane.

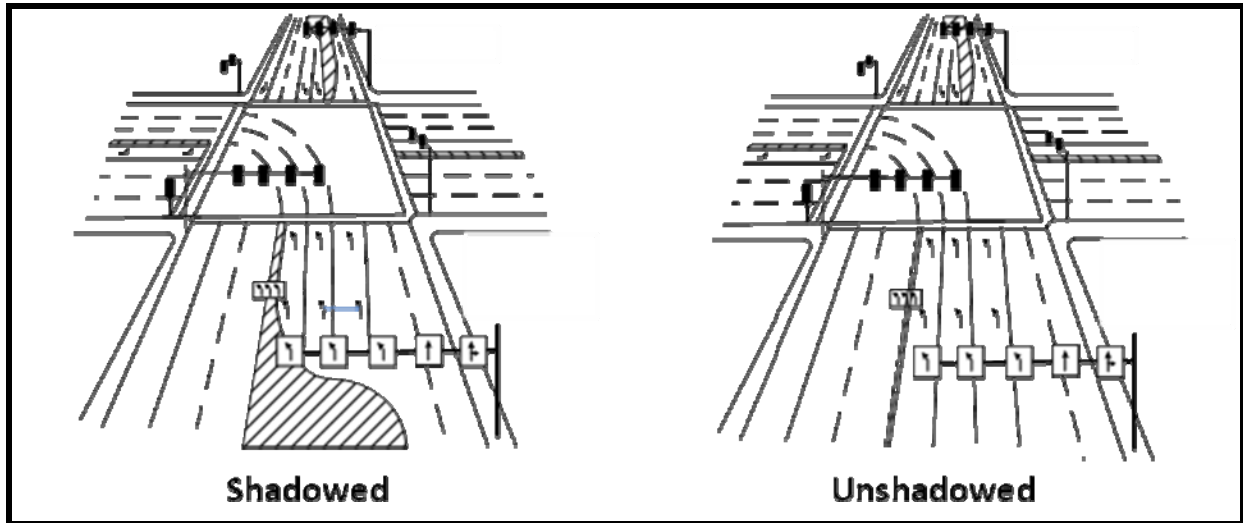


Figure 2-1. Shadowed or Unshadowed Triple Left-Turn Lanes.

### Right-Turn Lanes

#### *Fitzpatrick and Schneider (2004)*

This study focused on speed on right-turn lanes, including the 85<sup>th</sup> percentile speed and free flow speeds, and factors that could affect the pedestrian's path.

- Speed on right-turn lane: The authors conducted a study to collect the free flow speed of vehicles traveling through a right-turn lane. In this study, the free flow condition was defined as the right-turning vehicle having a minimum of 5 seconds headway and a minimum of 3 seconds separation with the following vehicle. They collected data using pneumatic tubes and a video camera. The authors investigated the impacts of the variables, including corner radius, channelization, right-turn lane length, and right-turn lane width, on the turning speeds. They used the analysis of covariance method for developing models for the speed at the beginning of the turn and near the middle of the turn, respectively. The results showed that:
  - Variables that affect the turning speed at an exclusive right-turn lane include: type of channelization present (either lane line or raised island), right-turn lane length, and corner radius.

- Variables that affect the turning speed at an exclusive right-turn with island design include: corner radius, right-turn lane length, and island size at the beginning of the turn and corner radius, right-turn lane length, and turning roadway width near the middle of the turn.
- 85<sup>th</sup> percentile speed: The results of this study showed that the 85<sup>th</sup> percentile speed near the middle of the right-turn lane ranged from 13.1 to 20.5 mph, and ranged from 17.4 to 28.5 mph at the beginning of the right-turn lane. The authors also used a regression analysis to predict the 85<sup>th</sup> percentile speed at the beginning of a right-turn lane and near the middle of the right-turn lane based on the 85<sup>th</sup> percentile speed data. The developed equation for predicting the speed at the beginning of the right-turn lane is:

$$V_{85BT} = 17.50 - 1.00 \text{ Chan} + 0.10 \text{ CR} - 0.006 \text{ Len} + 0.13 \text{ Wid} \quad (3)$$

Where:

$V_{85BT}$  = 85<sup>th</sup> percentile free-flow speed near the beginning of the right-turn (mph).

Chan = channelization present at site, Chan = 0 for raised island and 1 for lane line.

CR = corner radius (ft).

Len = length of right-turn lane (ft).

Wid = width of right-turn lane at start of right-turn (ft).

If the length and width of the right-turn lane is not readily available and the average values of 12 ft for lane width and 193 ft for lane length are assumed, the Equation (3) becomes:

$$V_{85BT} = 17.90 - 1.00 \text{ Chan} + 0.10 \text{ CR} \quad (4)$$

Note that, in this study, all the equations were developed based on the data collected at 17 single right-turn lanes that have the following features:

- Corner radius range is 33 to 86 ft.
- Right-turn lane length range is 115 to 300 ft.
- Right-turn lane width range is 9 to 15 ft.

The equation for predicting the speed near the middle of the right-turn lane is:

$$V_{85MT} = 13.03 + 0.23 \text{ Chan} + 0.06 \text{ CR} - 0.01 \text{ Len} + 0.40 \text{ Wid} \quad (5)$$

Where:

$V_{85MT}$  = 85<sup>th</sup> percentile free-flow speed near the middle of the right-turn (mph).

Chan = channelization present at site, Chan = 0 for raised island and 1 for lane line.

CR = corner radius (ft).

Len = length of right-turn lane (ft).

Wid = width of right-turn lane at start of right-turn (ft).

If the length and width of the right-turn lane is not readily available and the average values of 12 ft for lane width and 193 ft for lane length are assumed, the Equation (5) becomes:

$$V_{85BT} = 15.90 + 0.23 \text{ Chan} + 0.06 \text{ CR} \quad (6)$$



- *Free-flow speed:* The authors also developed a regression model for predicting the average free-flow speed at the beginning of a right-turn and near the middle of the right-turn. The equations developed for predicting the speed near the beginning of the right-turn are:

$$VBT_{\text{island}} = 18.25 + 0.08 \text{ CR} - 0.02 \text{ Len} + 0.13 \text{ Wid} \quad (7)$$

$$VBT_{\text{line}} = 13.65 + 0.21 \text{ CR} - 0.02 \text{ Len} + 0.06 \text{ Wid} \quad (8)$$

Where:

$VBT_{\text{island}}$  = free-flow speed near the beginning of the right-turn when an island is present (mph).

$VBT_{\text{line}}$  = free-flow speed near the beginning of the right-turn when only a line separates the right-turn lane from the through lane (mph).

CR = corner radius (ft).

Len = length of right-turn lane (ft).

Wid = width of right-turn lane at start of right-turn (ft).

The developed equation for predicting the speed near the middle of the right-turn is:

$$VMT_{\text{island}} = 18.93 + 0.06 \text{ CR} - 0.03 \text{ Len} - 0.06 \text{ Wid} \quad (9)$$

$$VMT_{\text{line}} = 4.47 + 0.10 \text{ CR} - 0.01 \text{ Len} + 0.70 \text{ Wid} \quad (10)$$

Where:

$VMT_{\text{island}}$  = free-flow speed near the middle of the right-turn when an island is present (mph).

$VMT_{\text{line}}$  = free-flow speed near the middle of the right-turn when only a line separates the right-turn lane from the through lane (mph).

CR = corner radius (ft).

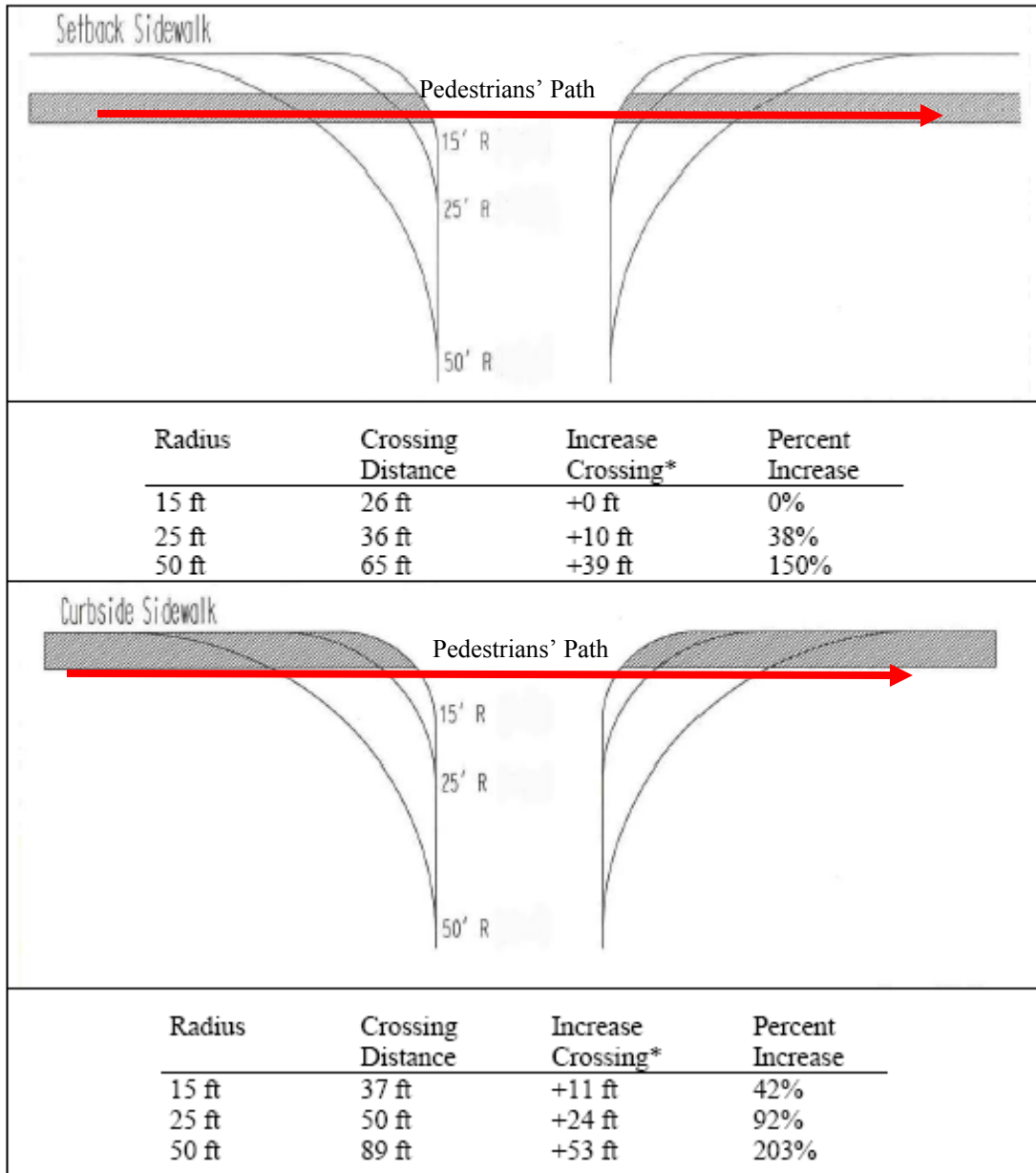
Len = length of right-turn lane (ft).

Wid = width of right-turn lane at start of right-turn (ft).

- *Impacts of geometric design on pedestrian's path:* According to Figure 2-2 provided by the American Association of State Highway and Transportation Officials (AASHTO), the authors concluded that curb radius can affect the pedestrian's path. That is, if the crosswalk is located inside the corner, the pedestrian's path increases as the curb radius increases. This could lead to longer crossing times for pedestrians and subsequently increases the clearance interval for the traffic signal timing.

## Summary of Operational Studies

The following two tables summarize the major findings of operational studies on triple left-turn lanes and right-turn lanes. Table 2-1 shows the findings on triple left-turn lanes, and Table 2-2 shows the findings on right-turn lanes.



\* Based on comparison with setback sidewalk with 15 ft radius. *Source: AASHTO (2001)*

**Figure 2-2. Added Crosswalk with Increased Radius.**  
 (Illustrated Using a 26 ft Roadway, 5 ft Sidewalk, and 6 ft Planting Strip for the Setback Sidewalk)

**Table 2-1. Summary of Operational Studies on Triple Left-Turn Lanes.**

Saturation Flow Rates				Influencing Factors on Saturation Flow Rates		Left-Turn Factor ( $f_{LT}^*$ )	Lane Utilization ( $f_{LU}^{**}$ )	Reference
Inner	Middle	Outer	Average	Factors that have Significant Impacts	Factors that Do Not Have Significant Impacts			
1,946	1,950	1,891	1,930	<ul style="list-style-type: none"> <li>Lane location</li> <li>Time of day</li> <li>Time of week</li> </ul>	<ul style="list-style-type: none"> <li>Site location</li> <li>Weekdays</li> </ul>		Drivers prefer inner and middle lanes to outer lane	Leonard (1994)
			1,830		Lane location	1.0		ITE Technical Council Committees 5P-5 and 5P-1 (1995)
1,773	1,809	1,825				0.95		Ackeret (1996)
			A range of 1,544 to 2,150	Time of day	Lane location			Courage et al. (2002)
1,852	1,867	1,858	1,859	<ul style="list-style-type: none"> <li>Skewness</li> <li>Street type</li> <li>Approach grade</li> <li>Approach type</li> </ul>	<ul style="list-style-type: none"> <li>Intersection type</li> <li>Shadowing effect</li> <li>Railway effect</li> </ul>	0.915	$f_{LU} = 0.88$ Affected by the geometric configuration factors	Sando and Mussa (2003)

\*:  $f_{LT}$  is the ratio between the average saturation flows of the left-turning vehicles and those of the through vehicles

\*\* :  $f_{LU} = V_g / (V_{g1} * N)$  where  $V_g$  = the unadjusted demand flow for the lane group in vehicles per hour

$V_{g1}$  = the unadjusted demand flow on a single lane in the lane group with the highest volume in vehicles per hour

N = the number of lanes in the lane group

**Table 2-2. Summary of Operational Studies on Right-Turn Lanes.**

85 <sup>th</sup> Percentile Free Flow Speed (mph)		Influencing Factors on Speed		Impacts of Geometric Design on Pedestrian's Path	Reference
Beginning of Right-Turn Lane	Middle of Right-Turn Lane	Exclusive Right-Turn Lane without Island Design	Exclusive Right-Turn Lane with Island Design		
Range from 13.1 to 20.5	Range from 17.4 to 28.5	<ul style="list-style-type: none"> <li>• Type of channelization present (lane line or raised island).</li> <li>• Right-turn lane length corner radius.</li> </ul>	<p>At the beginning of the turn:</p> <ul style="list-style-type: none"> <li>• Right-turn lane length.</li> <li>• Island size.</li> <li>• Corner radius.</li> </ul> <p>In the middle of the turn:</p> <ul style="list-style-type: none"> <li>• Corner radius.</li> <li>• Right-turn lane length.</li> <li>• Turning roadway width.</li> </ul>	Increase of curb radius will result in the increase of the length of the pedestrian's path.	Fitzpatrick and Schneider (2004)

## 2.2 SAFETY STUDIES

### Triple Left-Turn Lanes

Safety studies on triple left-turns have focused on the frequency and severity of the crashes involving triple left-turn movements. The following is a brief introduction of the previous studies on this topic.

#### *Mitchell (1993)*

Mitchell conducted a safety study at six intersections with triple left-turn lanes. The results of this study showed that:

- At one of the six intersections, the triple left-turn related accidents account for more than 20 percent of the total crashes at that intersection.
- There was no indication of any degree of confusion, surprise, or uncertainty of the drivers who use the triple left-turn lanes.
- Advance signing and proper markings are important in advising drivers using the triple left-turn lanes.
- Turning radii must be adequate for given design speeds.

#### *Belluccia et al. (1996)*

In this study, a project was conducted for the installation of a triple left-turn at an intersection in the City of St. Petersburg, Florida. In this project, the researchers conducted two different analyses.

- First, the authors conducted a fatal flaw analysis to find out the benefits of installing triple left-turn lanes at this intersection which produced these safety-related results:
  - Installing triple left-turn lanes solve a potential hazardous condition at this intersection by eliminating excessive vehicular queuing.
  - Installing triple left-turn lanes can provide immediate improvements that reduce unsafe conditions at the intersection.

- Second, the authors reviewed crashes at other triple left-turn lane intersections with similar traffic and geometric conditions. These intersections included four intersections in Florida with similar driver population, and four other intersections in Georgia, Nevada, and California, with similar intersection configurations (they are all 4-leg intersections). The results of this study showed that:
  - Less than 10 percent of the intersection crashes occurred in the triple left-turn approach.
  - All these triple left-turn related crashes were angle crashes involving left-turning vehicles colliding with opposing through vehicles perpendicular to the triple left-turn approach. These angle crashes were usually due to inadequate red phases or sight distance problems, and they were most likely not attributable to the operation of the triple left-turn lanes.

***Ackeret et al. (1999)***

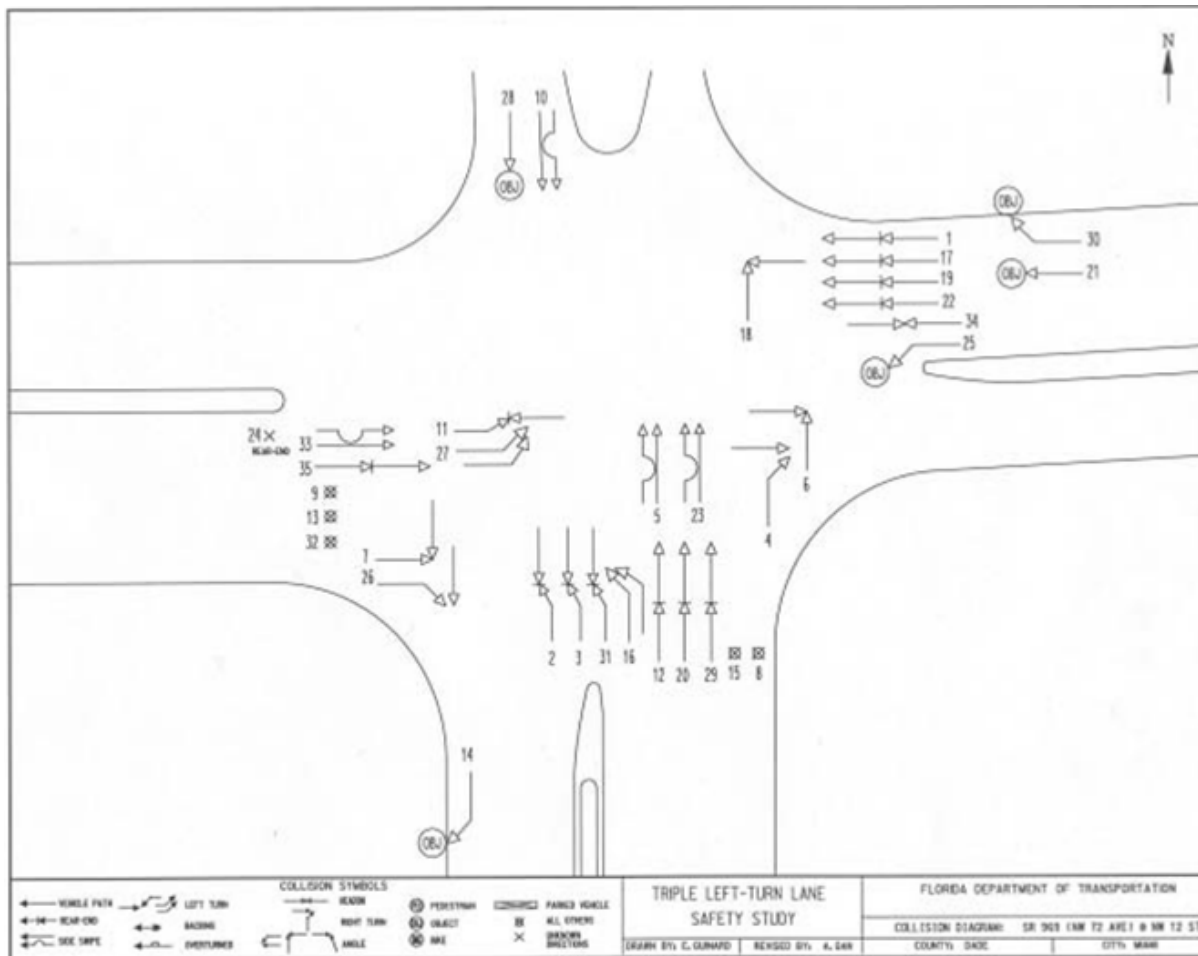
Ackeret et al. (1999) compared the number of sideswipe crashes, the percentage of sideswipe crashes, and the percentage of triple left-turn related sideswipe crashes of the total sideswipe crashes, at five double left-turn lanes and three triple left-turn lanes in Las Vegas, Nevada, based on crash records from 1988 to 1997. The major findings of this study showed:

- The average sideswipe crash percentages at three triple left-turn lanes are significantly higher than those at the five double left-turn lanes.
- Upon further investigation, the higher sideswipe crash rate at the triple left-turn lane sites is due to the deficiency in the turning path geometry and the existence of downstream busy bus stops. The authors suggested that properly designed triple left-turn lanes may correct these adverse conditions and will result in similar crash rates as those of double left-turn lanes.

***Courage et al. (2002)***

The authors analyzed the safety performance of 11 triple left intersections in Florida to find if safety is compromised at triple left-turn sites. In this study, the following four different analyses were conducted:

- The authors visually presented the crash records at individual triple left-turn sites by using collision diagrams (see Figure 2-3 as an example). From these collision diagrams, most of the crashes were of the rear-end type, with few of them occurring on the triple left-turn approach; and that the most common types of crashes here were sideswipe, angle, and left-turn. Additionally, according to accident reports, crashes during daytime were found to occur more often when peak hour volumes were present in the intersection.



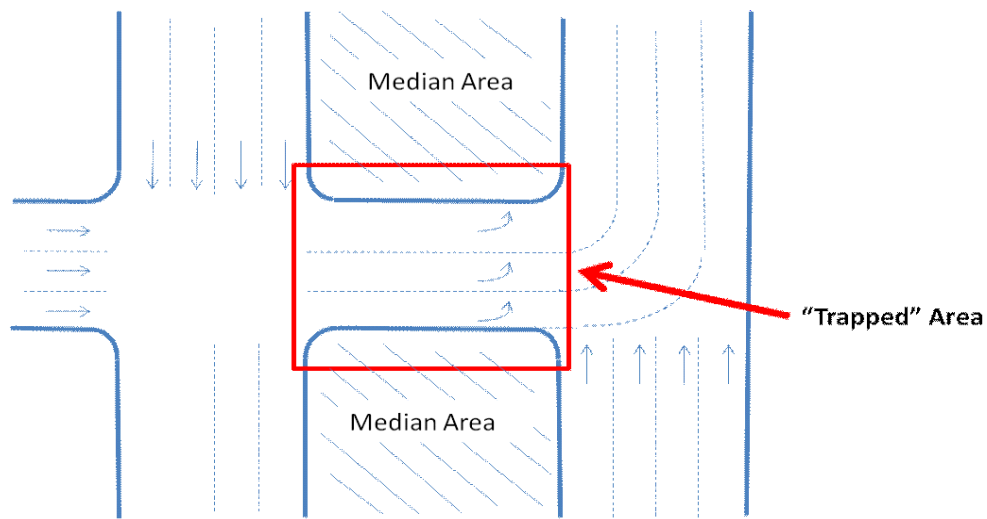
**Figure 2-3. Collision Diagram for Intersection SR 969 (NW 72<sup>nd</sup> Avenue) at NW 12<sup>th</sup> Street.**

*Source: Courage et al. (2002)*

- The authors examined the overall safety performance of 11 triple left-turn lanes at studied intersections by two types of studies:
  - Using crash frequency analysis, the authors compared the percentage of crashes involving triple left-turn traffic (TLT crash percentage) with the percentage of triple left-turn movements (TLT movements) at the intersection. The basic idea is that if TLT crash percentage is less than the percentage of TLT movements, it means that triple left-turns do not cause a disproportionately higher number of crashes compared with the single or double left-turn approaches at the same sites. Otherwise, it means that triple left-turns can have adverse impacts on safety. The results of this study showed that triple left-turn lanes did not contribute a higher proportion of left-turn related crashes compared to the single and double left-turn lanes at the same intersections.
  - Using crash severity analysis, the authors compared the percentage of injury crashes involving triple left-turn lanes with the percentage of injury crashes involving non-triple left-turn lanes. The basic idea is that if the percentage of the injury crashes involving triple left-turn lanes is less than those involving non-triple left-turn lanes, it means that triple left-turn lanes do not cause more severe crashes. Otherwise, it

means that triple left-turn lanes do cause more severe crashes. The results of this study showed that triple left-turn lanes do not cause more severe crashes.

- To control the impacts of other influencing factors, such as geometric and traffic conditions, the studied intersections were grouped into three:
  - Four 3-legged intersections that serve high left-turn volumes with medium to high approach speeds;
  - Four intersections with storage areas “trapped” within a wide median area (see Figure 2-4).
  - Three 4-legged intersections that have minor opposing movements and have moderate to high approach speeds and volumes. Then, similarly, crash frequency and severity analysis were conducted for the intersections in each group. Triple left-turn traffic did not contribute a higher proportion of left-turn related crashes compared to the single and double left-turn movements at the same intersections, and crashes involving triple and non-triple left-turn traffic have the same severity level.



**Figure 2-4. Intersection with Storage Areas “Trapped” within a Wide Median Area.**

- The authors compared the crash rates at the double left-turn lane and the triple left-turn lane sites for different type of crashes with different severity levels, during different time periods of days, and under different road surface conditions. The results indicate that there are no significant differences in crash rates between triple left-turn lanes and double left-turn lanes for all these conditions.

### **Right-Turn Lane**

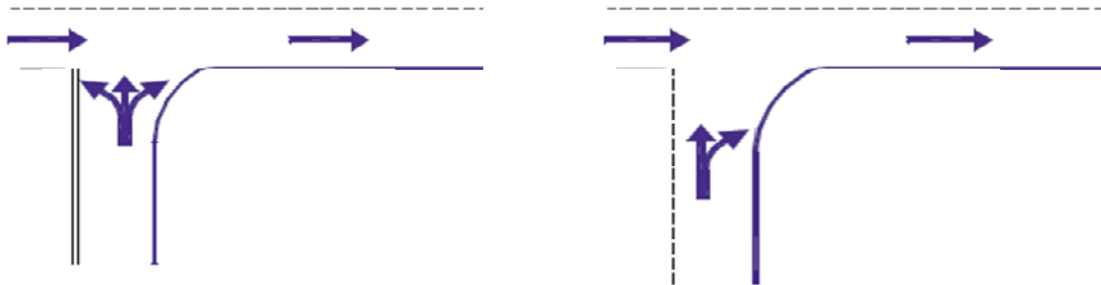
Safety studies on right-turn lanes have focused on the frequency and location of the crashes that occurred on right-turn lanes. The following is a brief introduction of the previous studies on this topic:

#### ***Dixon et al. (1999)***

Dixon et al. (1999) conducted a study at 17 signalized intersections located in Cobb County, Georgia, to evaluate the safety impact of different right-turn treatments. In this study, the

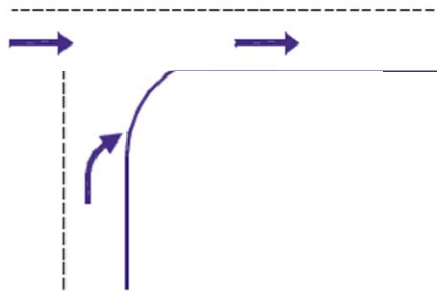
researchers selected a total of 70 right-turn movements at different intersections. The treatments of these right-turn movements can be grouped into five common types:

- A5—Shared right, no island, merge, no additional control (see Figure 2-5).



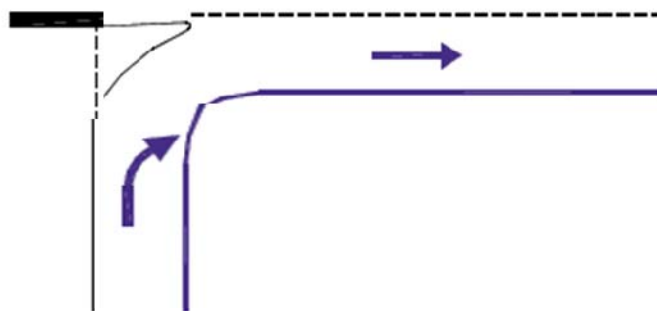
**Figure 2-5. Shared Right-Turn Lane with No Island, Merge, and No Additional Control.**

- B5—Exclusive right, no island, merge, no additional control (see Figure 2-6).



**Figure 2-6. Exclusive Right-Turn Lane with No Island, Merge, and No Additional Control.**

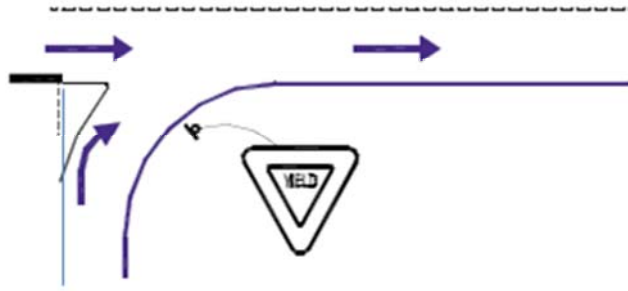
- D1—Exclusive right, raised island, add lane, no additional control (see Figure 2-7).



**Figure 2-7. Exclusive Right-Turn Lane with Raised Island, Add Lane, and No Additional Control.**

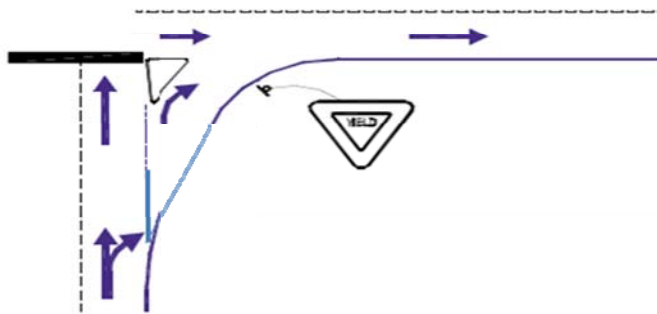


- D2—Exclusive right, raised island, merge, yield control (see Figure 2-8).



**Figure 2-8. Exclusive Right-Turn Lane with Raised Island, Merge, and Yield Control.**

- E2—Shared right, raised island, large turning radius, merge, yield control (see Figure 2-9).



**Figure 2-9. Shared Right-Turn Lane with Raised Island, Large Turning Radius, Merge, and Yield Control.**

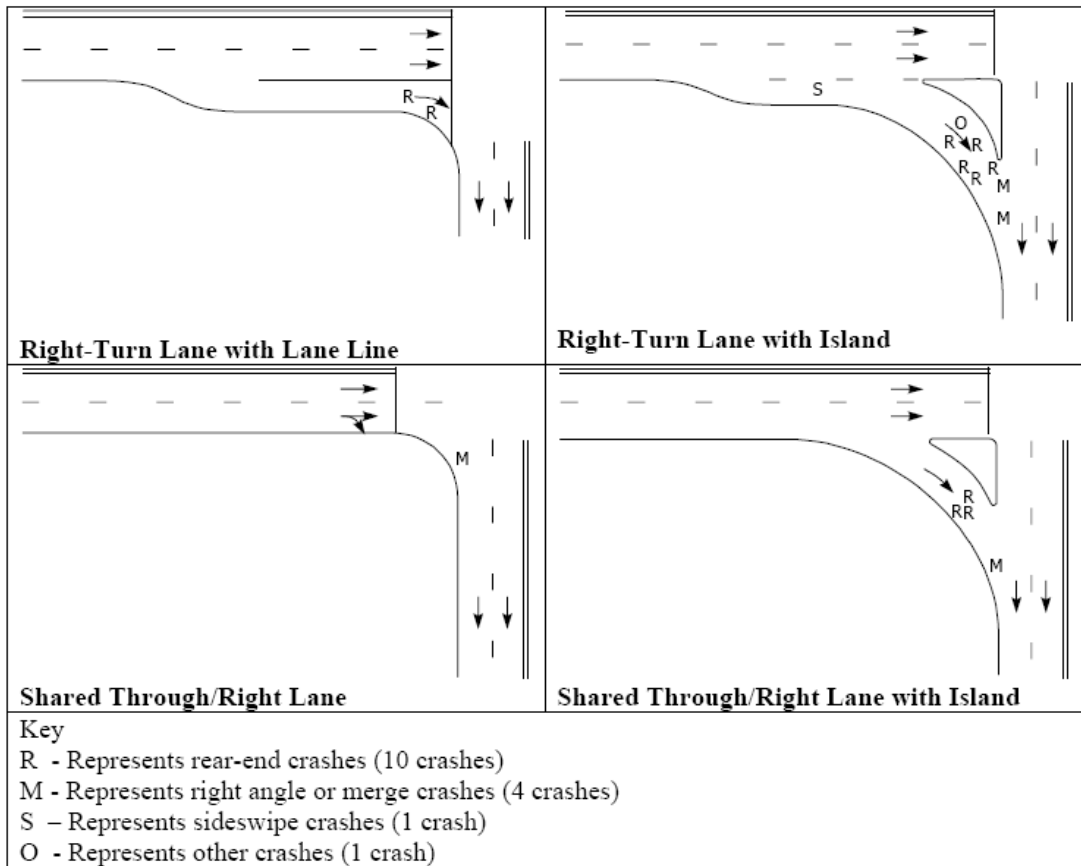
For each of these types, the frequency of crashes in a two-year period is estimated directly without considering the impacts of traffic exposure (the traffic volume). By comparing the estimated frequency of different types of crashes, these major findings can be obtained:

- Findings directly given in this report:
  - The use of a traffic island appears to reduce the number of right angle crashes.
  - The addition of an exclusive right-turn lane appears to correspond to elevated sideswipe accidents.
  - When no additional control is implemented, the addition of an exclusive right-turn lane on the cross street for right-turn vehicles does not appear to reduce the number of rear-end crashes.
- Other findings based on the results presented in this paper:
  - The addition of an exclusive right-turn lane appears to increase the average number of right-turn crashes per site per year. Note that this result may be due to the fact that the intersections with an exclusive right-turn lane have relative higher turning volumes that increase the risk of sideswipe accidents.
  - The use of a traffic island appears to increase the average number of right-turn crashes per site per year.

**Fitzpatrick and Schneider (2004)**

The authors conducted two studies to evaluate the right-turn lane crashes based on the crash data collected at five intersections in Irving and four intersections in College Station, Texas. These two studies are:

- **Crash frequency study:** The authors grouped the crashes into six categories—including rear-end type I (through or left-turn lane), rear-end type II (right-turn lane), angle type I (through lane), angle type II (left-turn lane), sideswipe, and others—to find the percentage of different types of crashes involving a right-turn vehicle. These results showed that only a small percentage (16/211) of the crashes involve right-turn vehicles.
- **Affects of right-turn treatments:** The authors determined the locations of right-turn lane crashes with respect to the types of right-turn treatments. These types include right-turn lane with lane line, right-turn lane with island, shared through/right lane, and shared through/right lane with island (see Figure 2-10).



**Figure 2-10. Summaries of Crashes by Right-Turn Treatment Type.**

*Source: Fitzpatrick and Schneider (2004)*

The results showed that:

- Sites with islands have a higher number of crashes than sites without islands. This result is consistent with the findings in Dixon et al. (1999), i.e., the use of a traffic island appears to increase the average number of right-turn crashes per site per year.
- The shared through/right-turn lane had the lowest number of crashes. This result is consistent with the findings in Dixon et al. (1999), i.e., the addition of an exclusive right-

turn lane appears to correspond to an elevated average number of right-turn crashes per site per year.

### ***Summary of Safety Studies***

The findings from the safety studies on triple left-turn and right-turn lanes are summarized as follows:

- *For triple left-turn lanes*, three of the four studies found that the triple left-turn lane does not cause higher crash rates and more severe crashes. Only one study found that triple left-turn lanes cause higher crash rates. However, upon further investigation, the authors suggested that properly designed triple left-turn lanes may correct these adverse conditions and will result in similar crash rates as those of double left-turn lanes.
- *For right-turn lanes*, the major findings are:
  - The use of a traffic island appears to reduce the number of right angle crashes; however, it increases the average number of right-turn crashes per site per year.
  - The addition of an exclusive right-turn lane appears to increase the number of sideswipe accidents, and when no additional traffic control is implemented, it does not appear to reduce the number of rear-end crashes.

## **2.3 EXISTING WARRANTS AND GUIDELINES**

### **Triple Left-Turn Lanes**

This section includes three parts:

- Results from existing studies.
- Current practice.
- Summary.

### ***Results from Existing Studies***

Existing studies were used to investigate and develop the existing warrants and guidelines on the design and installation of triple left-turn.

#### ***Ackeret (1994)***

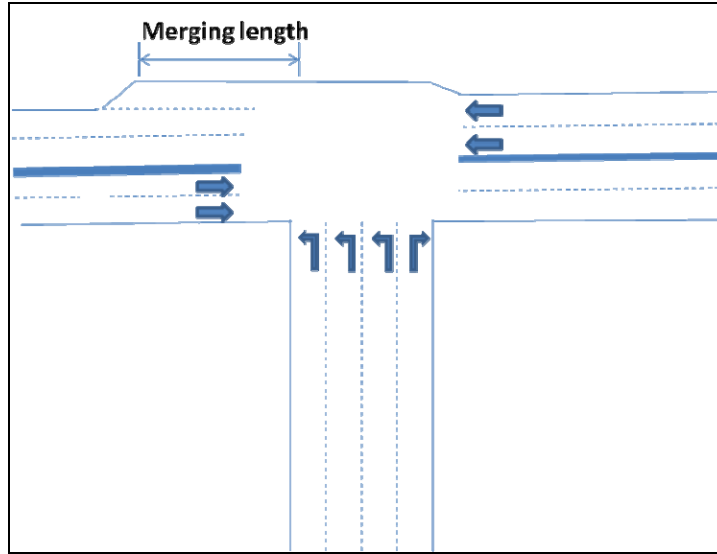
Based on the design and operational experiences collected from the traffic engineers within the Las Vegas Metropolitan area of Clark County, Nevada, this study recommended the following general guidelines for the geometric design of triple left-turn lanes:

- *Inappropriate Conditions for Installation of Triple Left-Turn Lanes.*
  - There is a potential for a high number of pedestrian-vehicle conflicts.
  - Left-turning vehicles are not anticipated to queue evenly within the provided left-turn storage lanes due to downstream conditions.
  - Certain conditions may obscure or result in confusing pavement channelization markings within the intersection.
  - Right-of-way (ROW) restrictions prohibit adequate design vehicle turning maneuver space within the intersection.
  - The installation is not economically justified when compared with other alternatives to improve intersection capacity.

- *Geometric Design Guidelines.*
  - For roadways in truck-restricted areas, select the design vehicle governed by a single-unit truck/bus. Otherwise, select the design vehicle governed by WB-50 (a type of semi trailer, see Harwood et al. 2003).
  - The lateral clearance between the running design vehicles should be at least 2 ft on each side of the design vehicle overhang limits within the turning maneuver.
  - The lateral vehicle body clearance between opposing vehicles, measured between the opposing turning paths, should be 10 ft.
  - Left-turn approach lane widths to a triple left-turn lane approach should be at least 11 ft (12 ft desirable).
  - Similarly, the downstream departure lane widths should be at least 11 ft (12 ft desirable).
  - The median islands should be at least 2 ft wide, with a desirable width of 4 ft.
  - Determination of the length of storage bay is based on the anticipated left-turn arrival rates, the signal cycle length, and the need to provide sufficient left-turn storage bay length to prevent vehicles from queuing into the adjacent through lane.
  - Determination of approach taper length to the triple left-turn bay is based on the roadway design speed and a local preference for reverse curves versus taper sections.
- *Roadway Delineation and Signage Guidelines.*
  - Advance overhead signage should be used to inform drivers of lane options. These signs should be supplemented with appropriate downstream lane destination messages if they will reduce downstream weaving maneuvers.
  - Skip lines, preferably comprised of raised pavement markers (RPMs), should be used through the intersection with appropriate spacing to control the multiple turning paths and keep each vehicle within its lane.
- *Traffic Signal Control Guidelines.*
  - A fully protected signal phase is required for triple left-turn lanes.
  - All three left-turn lanes should be provided with a signal indication over each turning lane.
  - Split phasing of the signal operation is required for the triple left-turn approaches with outer lane shared with through movements to prevent conflicts with opposing left-turn and through movements on two-way streets.
  - Special mast arm and signal pole equipment with cantilever mast arm lengths of 60 – 70 ft have been required to provide left-turn signal faces over each turning lane.

Shen (2001)

- *Merging Section Guidelines:* Researchers sought to develop models for determining the minimum length of the merging section for downstream lane reductions at triple left-turn lanes. Note that if the number of receiving lanes is less than the number of left-turn lanes, a sufficient number of receiving lanes with enough length must be built before the installation of multiple left-turn lanes. This situation creates a merging section with a lane-drop condition someplace downstream of the triple left-turn lanes. The length of this merging section is measured from the beginning of the departing approach downstream of the triple left-turn to the beginning of the lane-drop location, excluding the lane-drop taper section. Figure 2-11 shows an example of such a geometric configuration and the associated merging section.



**Figure 2-11. Triple Left-Turn Lanes with Downstream Lane Drop.**

*Source: Shen (2001)*

The authors first selected the appropriate measure of effectiveness (MOE), such as the average delay, for measuring the quality of traffic flow at the downstream merging section of triple left-turn lanes. Then, the influencing factors, including minimum merging section length, green time splits, the percentage of heavy vehicles and the design free-flow speed, on the selected MOEs were identified. After that, the CORSIM model was used for simulating the traffic operation in different scenarios with different values of the influencing factors. By changing the merging section lengths from long to short in the traffic simulation, the minimum required lengths of the merging section were derived for different scenarios. Table 2-3 presents the results.

**Table 2-3. Minimum Merging Section Lengths for Triple Left-Turn Lanes.**

Green time(s)	Percent of heavy vehicles						
	0%	5%	10%	15%	20%	25%	30%
<b>Downstream free-flow speed = 35 mph</b>							
10	200	212	223	233	242	249	255
20	214	231	246	260	273	284	294
30	228	249	268	286	303	319	333
40	242	268	291	313	334	354	372
50	256	287	314	340	365	388	411
60	270	305	336	366	395	423	450
<b>Downstream free-flow speed = 45 mph</b>							
10	200	215	229	242	254	265	275
20	214	236	256	274	291	305	318
30	228	257	283	306	327	345	362
40	242	278	310	338	364	386	404
50	256	299	337	370	400	426	447
60	270	320	364	403	437	466	490
<b>Downstream free-flow speed = 55 mph</b>							
10	205	220	234	247	259	270	280
20	220	243	264	282	299	314	328
30	235	267	294	318	338	358	376
40	250	290	323	350	378	402	424
50	266	313	353	388	418	446	472
60	280	335	382	422	457	490	520

Source: Shen (2001)

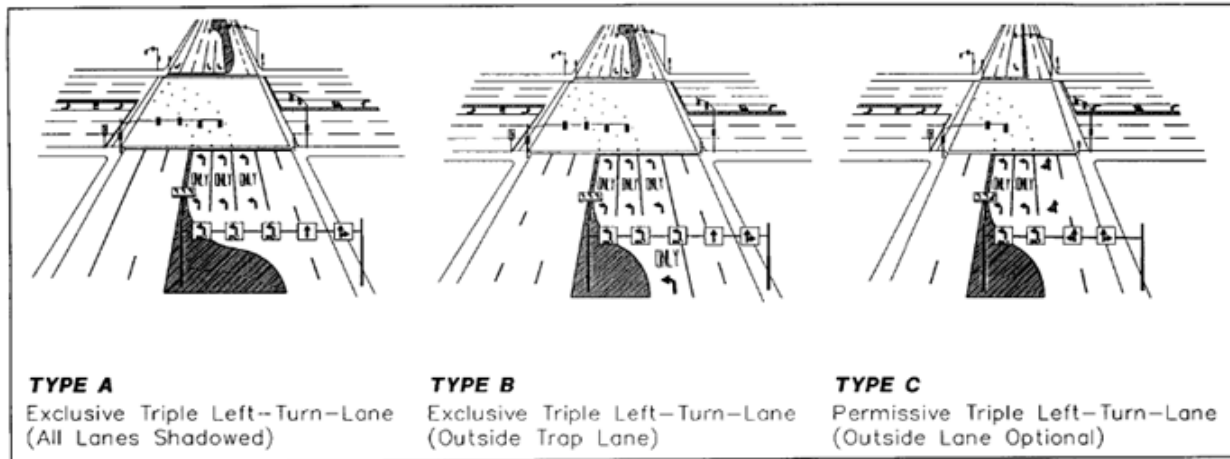
Comments on this study: The only MOE used in this study is average traffic delay at the downstream merging section. Since the length of the merging section is important for the safety of the intersection, some safety-related MOEs should also be used for deriving the minimum required lengths for the merging section.

*Courage et al. (2002)*

This study developed guidelines for triple left-turn installations based on the findings of their early operational and safety studies, which has been introduced in the previous parts of this report.

- *Geometric Design Guidelines.*
  - For most intersections on the State Highway System, design of triple lane turns should consider as a minimum an SU (single unit) vehicle and two P (passenger) vehicles turning simultaneously with a minimum 4 ft separation between the swept paths of the vehicles. The SU vehicle should be able to turn in all lanes.
  - Ackeret identifies three categories of triple left-turn configurations (see Figure 2-12). The Type A configuration should be used whenever possible:
    - To avoid the trap lanes associated with Type B configurations.

- To avoid the operation complexities of an optional through and left-turn lane associated with Type C configurations. Each turn lane should be marked with turn arrows and “ONLY” legends as appropriate. Type B and C configurations require special attention because of their potential for confusing drivers.



**Figure 2-12. Types of Triple Left-Turn Lanes Configuration.**

*Source: Ackeret (1994)*

- There should be no conditions that obscure, or result in confusing pavement marking within the intersection.
  - Merging section lengths for triple left-turn lanes should be at least 300 ft, and at least two continuous downstream lanes exist beyond that point. Three continuous downstream receiving lanes without a lane drop would be desirable.
  - The receiving leg should have a raised median island of at least 2 ft in width.
  - *Operational Analysis Guidelines.*
    - The operational analysis must take into account the effects of adjacent intersections, including:
      - Backup from a downstream signal on the receiving roadway.
      - Relative turning movement distribution at a downstream intersection that would compromise the ability of the receiving lanes to store the left-turn vehicles.
      - Heavy volumes from other approaches accommodated by the roadway that receives the left-turn lanes.
      - Upstream effects that could make it difficult to distribute the approaching left-turn lanes among the three left-turn lanes (e.g., a heavy single lane freeway exit ramp).
- The *Highway Capacity Manual* (1994) should be used for operational analysis only when there are no complicating factors of the type listed above. If there are any upstream or downstream influences, a microscopic simulation should be performed.
- Regarding the models for simulating the operation of triple left-turn lanes, this paper evaluated the capability of existing models, including Highway Capacity Software (HCS), SIDRA, TRANSYT-7F, and CORSIM, for capturing the unique features of triple left-turn lanes in their modeling. These unique features include the lane utilization of a triple lane left-turn movement, impacts of heavy vehicles, turning radius, the angle of intersection, upstream lane distribution, and downstream

spillover. The simulation results showed that none of these models recognizes the unique characteristics of triple left-turn lanes. Instead, they all model triple left-turn lanes as three-lane movements that happen to be turning left. There is little or no difference between three-lane through movements and triple left-turn movements.

- *Traffic Signal Control Guidelines.*
  - Special attention should be given to the signal timing intervals that are sensitive to bicycle and pedestrian requirements, including the Walk and Do Not Walk clearance intervals for pedestrians and the yellow and all red intervals for bicycles. Considering the increased roadway width, the signal-timing plan must be able to provide adequate Walk and Do Not Walk clearance intervals for all phases that accommodate through movements.
- *Safety Based Warrants.*
  - The use of triple left-turn lanes should be considered only when the safety record (number and type of collisions) at the intersection suggests that the proposed operation would not aggravate a demonstrated safety problem.
  - The use of triple left-turn lanes should be considered only when no problems are evident with respect to bicycle and pedestrian safety.

Qureshi et al. (2004)

In 2004, Qureshi et al. conducted a literature review and survey of 19 state DOTs on the following four topics:

- Criteria for determining when to install double and triple left-turns.
- The type of phasing to be used for dual and triple left-turn lanes.
- Whether to use “Dallas” or permitted lead-lag phasing for any left-turn lanes.
- Where to begin reducing the number receiving lanes downstream of an intersection with multiple left-turn lanes.

Based on the results of the literature review and survey, the researchers recommended the following guidelines on the design and operation of triple left-turn lanes:

- *Warrants for Triple Left-Turn Lane.*  
Capacity analysis should be used to determine when to upgrade to triple left-turn lane. If capacity analysis is infeasible, then upgrade dual left-turn lanes to triple left-turn lanes when the left-turning volumes reach 600 vph.
- *Traffic Signal Control Guidelines.*  
Protected-only phasing should be used for multiple left-turn lanes as it provides more safety to left-turners compared to other types of phasing.
- *Merging Section Guidelines.*  
Determine the length of merging section by using the guidelines Shen (2001) developed (see Table 2-3).

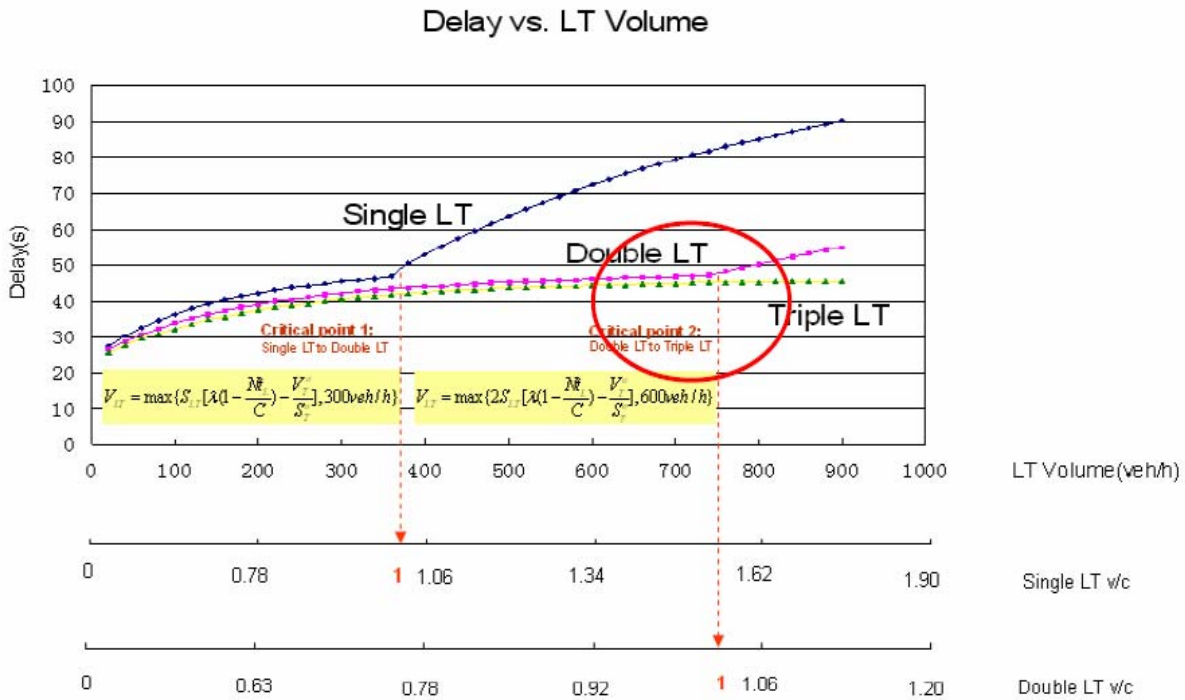
Yu et al. (2007)

In this paper, two types of warrants for multiple left-turn lanes are developed:

- *Volume and Capacity Warrants for Multiple Left-Turn Lanes:* A variable left-turn volume threshold was proposed for determining the upgrade of dual left-turn lanes to triple left-turn lanes based on intersection delay analysis (see critical point 2 in



Figure 2 13). From Figure 2-13, it can be seen that, beyond critical point 2, the average intersection delay will increase considerably.

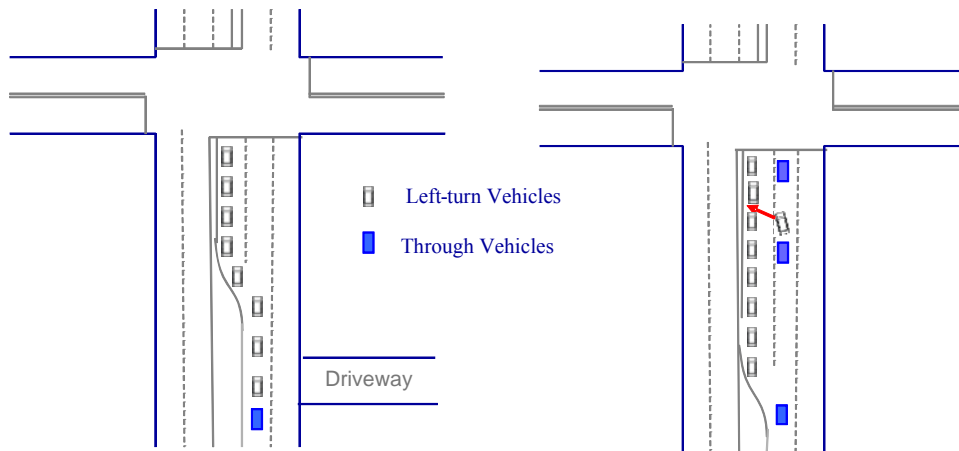


**Figure 2-13. Average Delay vs. Left-Turn Volume for Development of Left-Turn Volume-Based Warrants.**

Source: Yu et al. (2007)

- *Queue Length Based Warrants for Multiple Left-Turn Lanes:* Multiple-left turn lanes need to be provided when the left-turn queue is very long and causes the following two problems:
  - Left-turn lane overflow and it is not feasible to increase the length of the single left-turn lane.
  - Unbalanced queues between left-turn lane and the through lane. See Figure 2-14 for the situations that caused these two problems.

Finally, comprehensive guidelines for multiple left-turn lanes installation were developed by combining the developed warrants with the existing safety and geometric based warrants.



**Left-turn lane overflow**  
It is not feasible to increase the length of single left-turn lane.

**Unbalanced queues between left-turn lane and the through lane.**

**Figure 2-14. Two Problems in Left-Turn Operations.**

*Source: Yu et al. (2007)*

Yu et al. (2008)

In this study, the researchers analyzed the operational and safety impacts of different types of left-turn signal phasing. Based on the analysis results, they developed guidelines for selecting mode of left-turn signal control, sequence of left-turn signal phasing, and signal displays. According to the results of this study, the following key findings associated with the signal operations at triple left-turn intersections can be obtained:

- *Traffic Signal Control Guidelines.*
  - Protected-only mode should be used for triple left-turn lanes intersections.
  - Lead-lag sequence should be used for the triple left-turn sites where geometric conditions do not allow concurrent opposing left-turns.
  - Signal indications should be provided over each turning lane.
  - A secondary left-turn signal head may be needed at the far side of the intersection.

### ***Current Practice***

Previous studies have utilized surveys of state DOT personnel to solicit their current practices regarding the design and operation of triple left-turn and dual right-turn lanes. These surveys collected some of the following information:

- Implementation of triple left-turn or dual right-turn lanes.
- Current guidelines used by different states.
- Warrants for triple left-turn or right-turn lanes.
- Signal control strategies.
- Guidelines for downstream lane reduction.

Courage et al. (2002)

Courage et al. (2002) conducted a survey to obtain information related to double and triple left-turn lanes and to learn about possible ongoing studies being conducted in different states. Twenty-three state DOTs responded to the request and the findings about triple left-turn lanes are summarized here.

- *Implementation of Triple Left-Turn Lanes.*
  - California, Minnesota, New York, Nevada, North Carolina, Texas, and Florida have at least one triple left-turn lanes currently functioning.
  - Maryland, Mississippi, Nebraska, New Mexico, Oregon, and Washington are planning to install triple left-turn lanes.
- *Current Guidelines Used by Different States.*
  - Up-to-date specific design guidelines for triple left-turn lanes were not reported by any state.
  - States with triple left-turn lanes base their design on the following manuals:
    - Highway Capacity Manual (TRB).
    - Guidelines for Urban Major Street Design (ITE).
    - Intersection Channelization Design Guide (NCHRP Report 279).
    - A Policy on the Geometric Design of Highways and Streets (AASHTO).
  - State DOTs from California, Connecticut, Minnesota, New York, Oklahoma, South Dakota, Virginia, and Washington reported having “in house” design guidelines that are applied to the design of triple left-turn lanes.
- *Warrants for Triple Left-Turn Lanes.*
  - Maryland and New York DOT base the installation of multiple left-turn lanes on major determining factors such as right of way, critical lane analysis, level of service and operational characteristics.
  - Mississippi considers triple left-turn lanes for left-turn volumes greater than 600 vph.

Qureshi et al. (2004)

In 2003, Mohammad Qureshi et al. conducted a survey to determine the criteria for upgrading left-turn lanes to dual or triple lanes, the type of signal phasing to be used in the dual and triple left-turn lanes sites, and the downstream lane reduction guidelines. Sixteen states responded to the survey, and the findings for the triple left-turn lanes are summarized here.

- *Warrants for Triple Left-Turn Lanes:* Most of the states that responded do not have triple left-turn lanes. Only Nevada uses a rule-of-thumb criterion (left-turning volumes over 600 vph) to upgrade dual left-turn lane to triple left-turn lane.
- *Traffic Signal Control:* The types of signal phasing used at the triple left-turn lanes include:
  - The vast majority of the responding states use protected only phasing.
  - Only Montana uses permissive phasing.
  - Most of the states that responded to the survey replied that they were not familiar with ‘Dallas’ phasing.
- *Downstream Lane Reduction Guidelines.*
  - Montana, Rhode Island, and Wisconsin do not allow a reduction in number of receiving lanes downstream of the intersection with triple left-turn lanes.
  - For other states where downstream lane reduction is allowed, the guidelines for determining the minimum required merging section length are summarized in Table 2-4.

**Table 2-4. Guidelines for Determining the Minimum Required Merging Section Length.**

Guidelines	States	Reference
Depending on vehicle's destination, traffic distribution within the turning lanes and/or through lanes and the site conditions	Louisiana	Mohammad Qureshi et al. (2003)
Use ITE's Guidelines for Urban Major Street Design	Kansas	
Based on engineering judgment and Texas MUTCD requirements	Texas	
Use geometric constraints	Arkansas and Delaware	
Use AASHTO guidelines	Nevada and North Dakota	
Use rule of thumb	Maryland, Maine, Connecticut, South Carolina, and Washington	
Use SYNCHRO model	Oregon	

*TxDOT Roadway Design Manual (2010)*

In the *TxDOT Roadway Design Manual*, there are no guidelines for triple left-turn lanes, but there are some guidelines for dual left-turn and dual right-turn lanes, which are described here:

- *Guidelines for the Length of Dual Left-Turn and Right-Turn Lanes:* The length for dual right-turn lanes is the same as that for dual left-turn lanes, shown in Table 2-5.

**Table 2-5. Length of Dual Left-Turn or Right-Turn Lanes on Urban Streets.**

Speed (mph)	Deceleration Length (ft)	Taper Length (ft)	Storage Length (ft)
30	160	100	100
35	215	100	100
40	275	100	100
45	345	150	100
50	425	150	100
55	510	150	100

Source: *TxDOT Roadway Design Manual*

**Summary of Existing Warrants and Guidelines for Triple Left-Turn Lanes**

The existing warrants and guidelines for triple left-turn lanes are summarized in Table 2-6 and Table 2-7, respectively.

**Table 2-6. Summary of Existing Warrants for Triple Left-Turn Lanes.**

Category	Warrants For Triple Left-Turn Lanes		Reference
Inappropriate Situations for Installation of Triple Left-Turn Lanes	1) There is a potential for a high number of pedestrian-vehicle conflicts. 2) Left-turning vehicles are not anticipated to queue evenly within the provided left-turn storage lanes due to downstream conditions. 3) Conditions exist that obscure or result in confusing pavement channelization markings within the intersection. 4) ROW restrictions prohibit adequate design vehicle turning maneuver space within the intersection. 5) The installation is not economically justified when compared with other alternatives to improve intersection capacity.		Ackeret (1994)
Appropriate Situations for Installation of Triple Left-Turn Lanes	Volume based	Left turn volume > 600 vph (vehicles per hour)	Qureshi et al. (2004) and Courage et al. (2002)
		A variable left-turn volume threshold was proposed for determining the upgrade of dual left-turn lanes to triple left-turn lanes based on intersection delay analysis	
	Safety based	The use of triple left-turn lanes should be considered only when the safety record (number and type of collisions) at the intersection suggests that the proposed operation would not aggravate a demonstrated safety problem.	Courage et al. (2002)
		The use of triple left-turn lanes should be considered only when no problems are evident with respect to bicycle and pedestrian safety.	

**Table 2-7. Summary of Existing Guidelines for Triple Left-Turn Lanes.**

Category	Guidelines For Triple Left-Turn Lanes		Reference
Geometric Design Guidelines	Design vehicles	<ul style="list-style-type: none"> <li>For roadways on truck restricted areas, use single-unit (SU) truck/bus.</li> <li>Otherwise, use WB-50.</li> </ul>	Ackeret (1994)
		A minimum of an SU vehicle and two P vehicles turning simultaneously with a minimum 4 ft separation between the swept paths of the vehicles. The SU vehicle should be able to turn in all lanes.	
	Lateral clearance	Minimum = 2 ft.	Ackeret (1994)
	Clearance between opposing left turns	Minimum lateral vehicle body clearance = 10 ft.	
	Width of approach lane	Minimum Width = 11 ft. Desirable Width = 12 ft.	
	Storage bay length	Based on anticipated left-turn arrival rates, cycle length, need to prevent spillover to through lanes, and presence of adjacent upstream intersections and driveways.	
	Approach taper length	Based on design speed and local preference for reverse curves versus taper sections.	
	Configuration	Type A configuration (see Figure 2-12) should be used whenever possible.	Courage et al. (2002)

**Table 2-7. Summary of Existing Guidelines for Triple Left-Turn Lanes (Continued).**

Category	Guidelines for Triple Left-Turn Lanes		Reference
Geometric Design Guidelines (continued)	Roadway delineation and signage	Skip lines, preferably comprised of RPMs, should be used.	Ackeret (1994)
		Advance overhead signage should be used to inform drivers of lane options.	
		There should be no conditions that obscure, or result in confusing pavement markings within the intersection.	Courage et al. (2002)
		Each turn lane should be marked with turn arrows and ‘ONLY’ legends as appropriate.	
	Downstream departure lane	Minimum Width=11 ft. Desirable Width=12 ft.	Ackeret (1994)
		The minimum merging section length is suggested in Table 2-3.	Shen (2001) and Qureshi et al. (2004)
		Three downstream lanes should be available for at least 300 ft from the intersection.	Courage et al. (2002)
The receiving leg should have a raised median island of at least 2 ft in width.			
Operational Analysis Guidelines	Analysis must take into account the effects of adjacent intersections. The <i>Highway Capacity Manual</i> should be used for operational analysis only when there are no complicating effects from the adjacent intersections. Otherwise, a microscopic simulation should be performed.		Courage et al. (2002)
Traffic Signal Control Guidelines	Protected only phasing should be used for triple left-turn lanes.		Ackeret (1994 & 1996), Qureshi et al. (2004) and Yu et al. (2008)
	All three left-turn lanes should be provided with a signal indication over each turning lane.		Ackeret (1994) and Yu et al. (2008)
	Lead-lag sequence should be used for the triple left-turn sites where geometric conditions do not allow concurrent opposing left-turns.		Yu et al. (2008)
	A secondary left-turn signal head may be needed at the far side of the intersection.		
	Special mast arm and signal pole equipment with cantilever mast arm lengths of 60ft to 70ft have been required to provide left-turn signal faces over each turning lane.		Ackeret (1994)
	Split phasing of the signal operation is required for Type C triple left-turn facilities to prevent opposing left-turn and through movement conflicts on two-way streets.		
	Special attention should be given to the signal timing intervals that are sensitive to bicycle and pedestrian requirements, including the Walk and Do Not Walk clearance intervals for pedestrians and the yellow and all red intervals for bicycles.		Courage et al. (2002)

## Right-Turn Lane

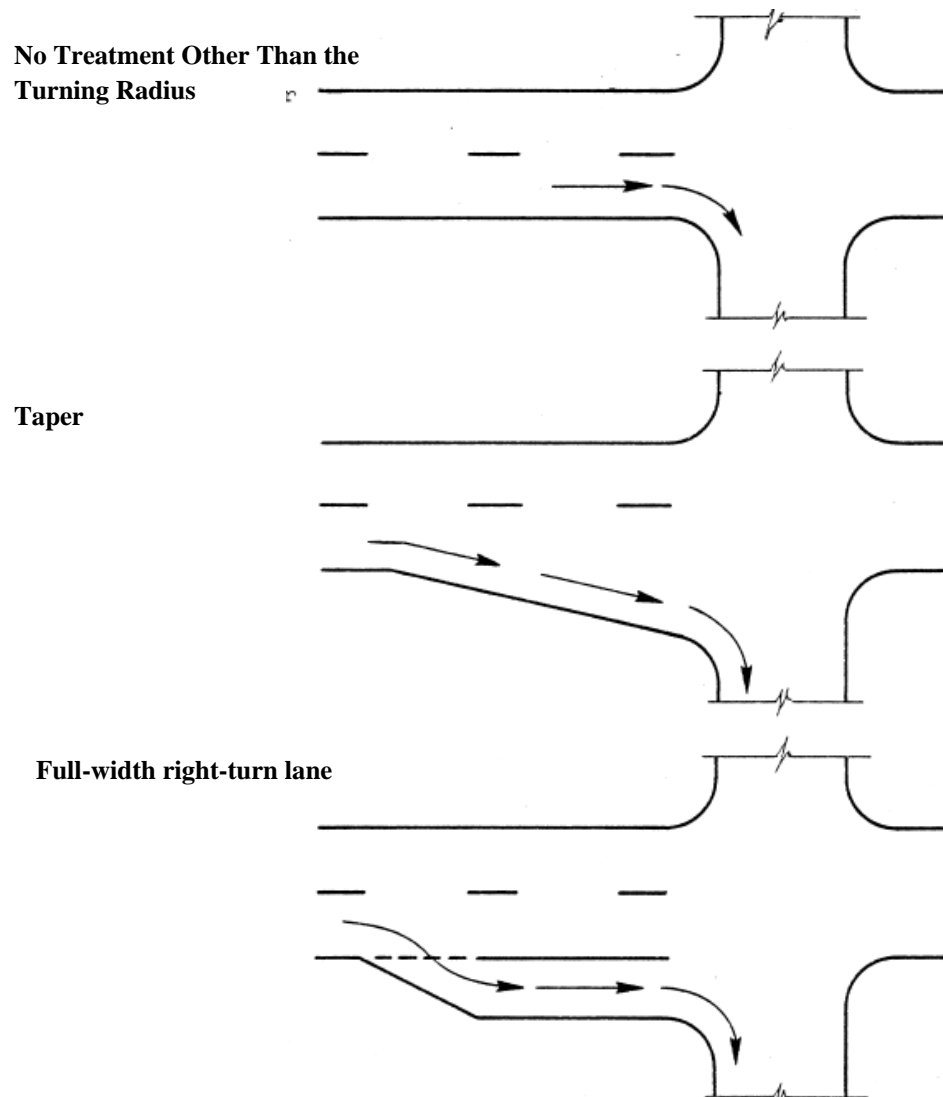
### *Results from Existing Studies*

The following existing warrants and guidelines on the design and installation of right-turn lanes have been investigated and developed by the following previous studies:

#### Cottrell (1981)

In 1981, Cottrell developed guidelines for right-turn treatments at different approaches by conducting field studies and a survey to 48 state DOTs to collect information about the standards used for the installation of different types of right-turn treatments. Three types of right-turn treatments were studied:

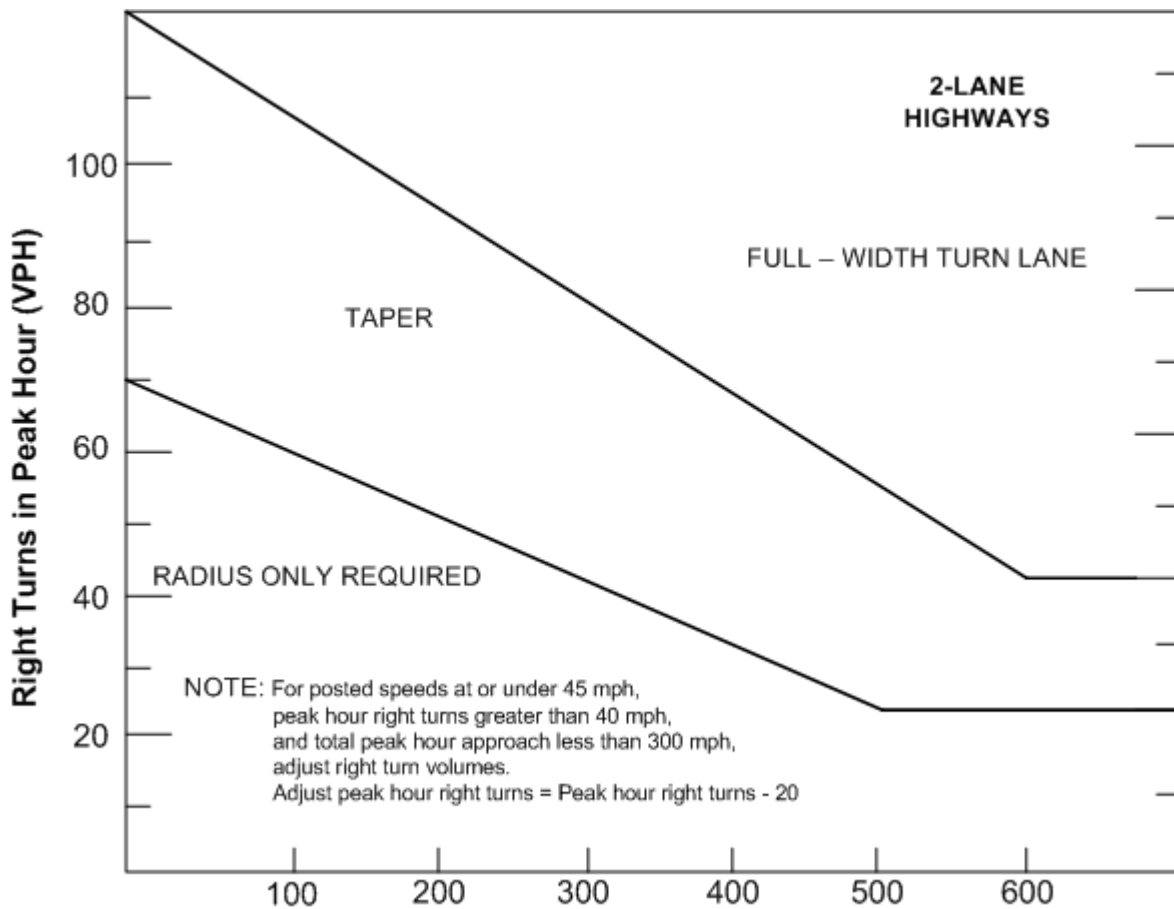
- No treatment other than the turning radius.
- Taper.
- Full-width right-turn lane. Figure 2-15 shows these three types of right-turn treatments.



**Figure 2-15. Types of Treatments for Right-Turn Movements.**

*Source: Cottrell (1981)*

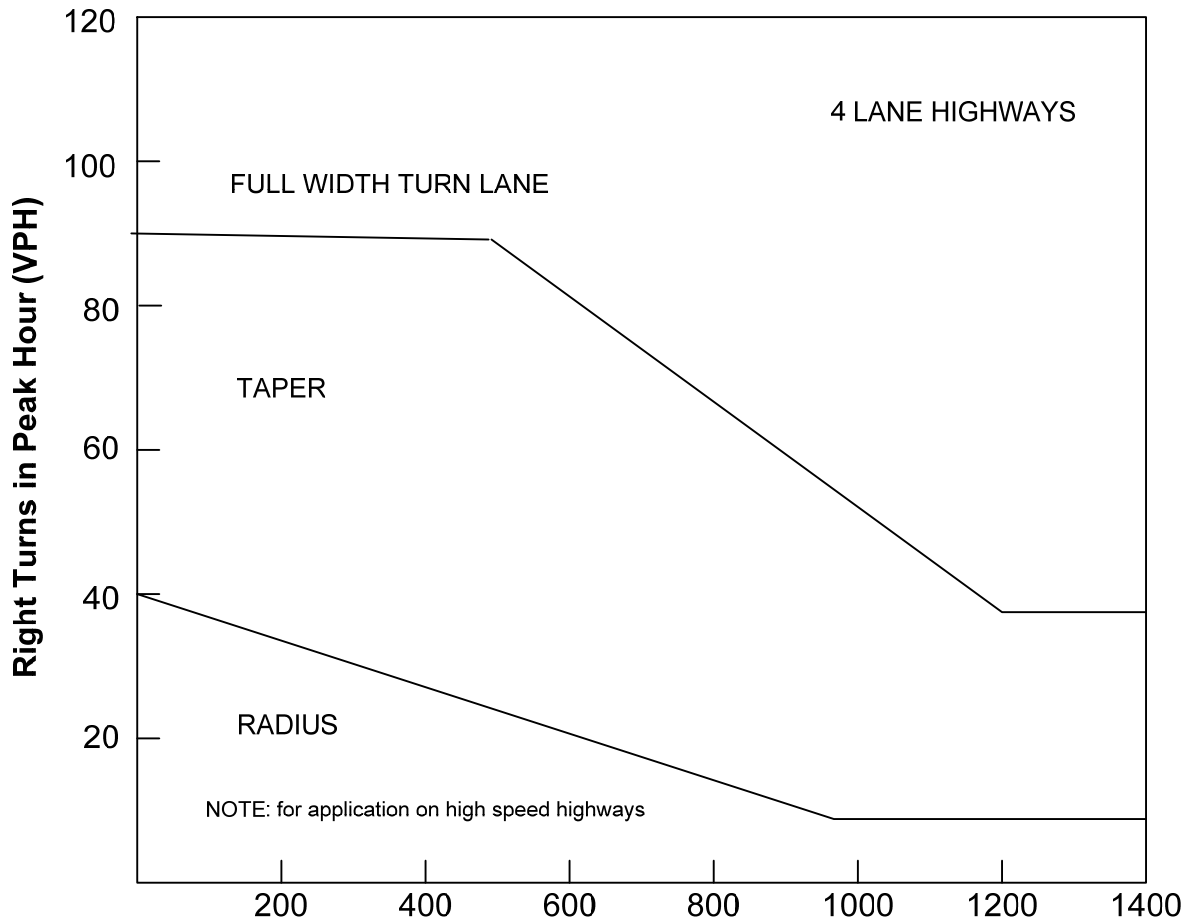
Data were collected from field studies, and the researchers used the Statistical Package for the Social Sciences (SPSS) for analyzing the total traffic volume and right-turn volume conditions at the intersections with and without the right-turn lane. Then, 48 state DOTs were surveyed to collect information about the standards used for the installation of different types of right-turn treatments. Finally, results from the field studies and surveys were combined, and guidelines were developed for two-lane and four-lane roadways separately. Figures 2-16 and 2-17 show the developed guidelines. In these figures, the area labeled “full-width turn lane” indicates the combinations of peak hour right-turn volume and the total peak hour traffic volume conditions that are suitable for right-turn lanes.



**Figure 2-16. Warrants for Right-Turn Treatments on Two-Lane Highways.**

*Source: Cottrell (1981)*





**Figure 2-17. Warrants for Right-Turn Treatments on Four-Lane Highways.**

*Source: Cottrell (1981)*

AASHTO (1994)

AASHTO's *A Policy on Geometric Design of Highways and Streets*, also known as the Green Book, provides the following warrants and guidelines for installation of right-turn:

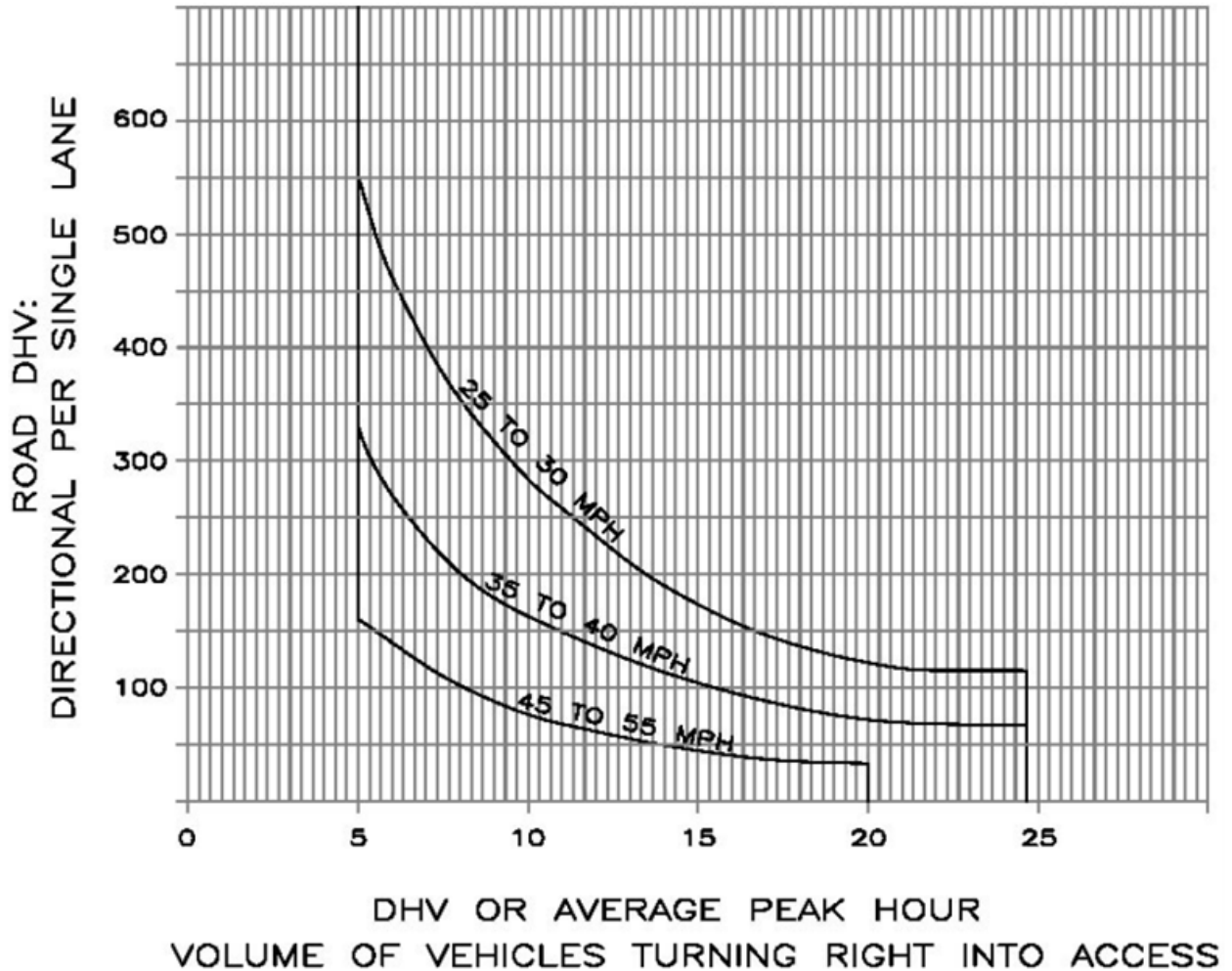
- *Warrants for Right-Turn Lanes:* It is recommended that right-turn lanes should be provided on high-speed and high-volume highways where a change in speed is necessary for vehicles entering or leaving the through traffic lanes. However, it does not give the specific speed or traffic volume-based criteria for the installation of right-turn lanes.
- Right-turn lanes can serve both as a deceleration lane before the vehicles making right-turns and an acceleration lane after the vehicles making right-turns in order to merge to the through traffic on the destination road. Functioning as a deceleration lane, right-turn lanes are advantageous, particularly on the approaches to at-grade intersections. Functioning as an acceleration lane, right-turn lanes are advantageous on roads without stop control and on all high-volume roads even with stop control where openings between vehicles in the peak-hour traffic streams are infrequent and short.
- *Design Guidelines:* The length of a right-turn bay is the sum of deceleration distance, taper, and queue storage length.

- Minimum deceleration lengths for right-turn lanes on grades of two percent or less, with an accompanying stop condition, for design speeds of 30, 40, and 50 mph are 235, 315, and 435 ft, respectively.
- Length of taper should be approximately 8 to 15 ft longitudinally to 1 ft transversely.
- The queue storage length, at signalized intersections, depends on the signal cycle length, the signal phasing arrangement, and the rate of arrivals and departures of left-turning vehicles. The storage length is a function of the probability of occurrence of events and should usually be based on one and one-half to two times the average number of vehicles that would store per cycle, which is predicated on the design volume. This length will be sufficient to serve heavy surges that occur from time to time.
- The queue storage length, at unsignalized intersections, may be based on the number of turning vehicles likely to arrive in an average two-minute period within the peak hour. As a minimum requirement, space for at least two passenger cars should be provided; with over 10 percent truck traffic, provisions should be made for at least one car and one truck. The two-minute waiting time may need to be changed to some other interval that depends largely on the opportunities for completing the left-turn maneuver. These intervals, in turn, depend on the volume of traffic. Where the volume of turning traffic is high, a traffic signal will usually be required. Note that right-turn lanes should be made for storing at least two vehicles.

Oregon State University (1996)

As shown in Figure 2-18, Oregon State University (1996) introduced the right-turn lane warrants adopted by the Colorado DOT as follows:

- When the design hour volume (DHV) of vehicles turning right into access is in the range from 5 DHV to 25 DHV, the warrants for right-turn lanes are shown in Figure 2-18.
- When the DHV of the right-turn into the access is less than 5 DHV, the right-turn lane may be required when the outside lane volume exceeds:
  - 250 DHV on a 45 to 55 mph highway.
  - 450 DHV on a 35 to 45 mph highway.
  - 600 DHV on a 25 to 30 mph highway.
- When the DHV of the right-turn into the access is more than 25 DHV, the right-turn deceleration lane is required when the outside lane volume exceeds:
  - 25 DHV on a 25 to 40 mph highway.
  - 20 DHV on a more than 40 mph highway.



**Figure 2-18. Warrants for Right-Turn Lanes.**

*Source: Oregon State University (1996)*

*Hasan et al. (1996)*

In this paper, guidelines were developed for right-turn treatments at unsignalized intersections and driveways on the state highway system of Kansas. The guidelines were based on the results of an economic analysis of the benefits and costs of constructing right-turn lanes and tapers at six different speeds (40, 45, 50, 55, 60, and 65 mph). Tables 2-8 and 2-9 show the guidelines developed in this paper, which indicate the marginal directional design hour volumes (DDHV) above which the benefits of right-turn treatments exceed their costs. Note that DDHV is the traffic volume for the rush hour period in the peak direction of flow, and this study found that DDHV is more significant than speed in warranting a right-turn treatment.

**Table 2-8. Minimum Right-Turn Directional Design Hour Volumes (DDHV)  
Required to Warrant Right-Turn Treatments for Two-Lane Highways.  
(Turning Speed = 15 mph)**

Roadway DDHV (vph)	Roadway Operating Speed (mph)											
	40		45		50		55		60		65	
	Lane	Taper	Lane	Taper	Lane	Taper	Lane	Taper	Lane	Taper	Lane	Taper
200				83	73	30	35	14	20	8	15	7
300			120	40	41	19	24	9	15	7	12	6
400	200	85	52	27	30	14	19	8	12	6	11	5
600	50	27	26	13	20	9	14	6	10	5	9	4
800	25	12	16	8	15	7	11	5	9	4	8	3
1000	14	8	12	5	11	5	9	4	8	3	7	3
1200	10	6	9	4	9	4	8	4	7	3	7	3

Source: Hasan et al. (1996)

**Table 2-9. Minimum Right-Turn Directional Design Hour Volumes (DDHV)  
Required to Warrant Right-Turn Treatments for Four-Lane Highways.  
(Turning Speed = 15 mph)**

Roadway DDHV (vph)	Roadway Operating Speed (mph)											
	40		45		50		55		60		65	
	Lane	Taper	Lane	Taper	Lane	Taper	Lane	Taper	Lane	Taper	Lane	Taper
300						55	75	25	19	9	19	9
400			145	65	75	30	40	17	16	8	15	8
500		140	95	50	57	25	32	14	14	7	13	7
600	160	80	65	30	42	18	26	11	12	6	12	6
800	70	40	37	18	28	12	19	8	11	5	11	5
1200	25	14	20	10	18	8	14	6	8	4	8	4
1600	15	8	14	6	13	6	10	5	7	3	7	3
2000	10	6	9	6	9	4	8	4	6	3	6	3

Source: Hasan et al. (1996)

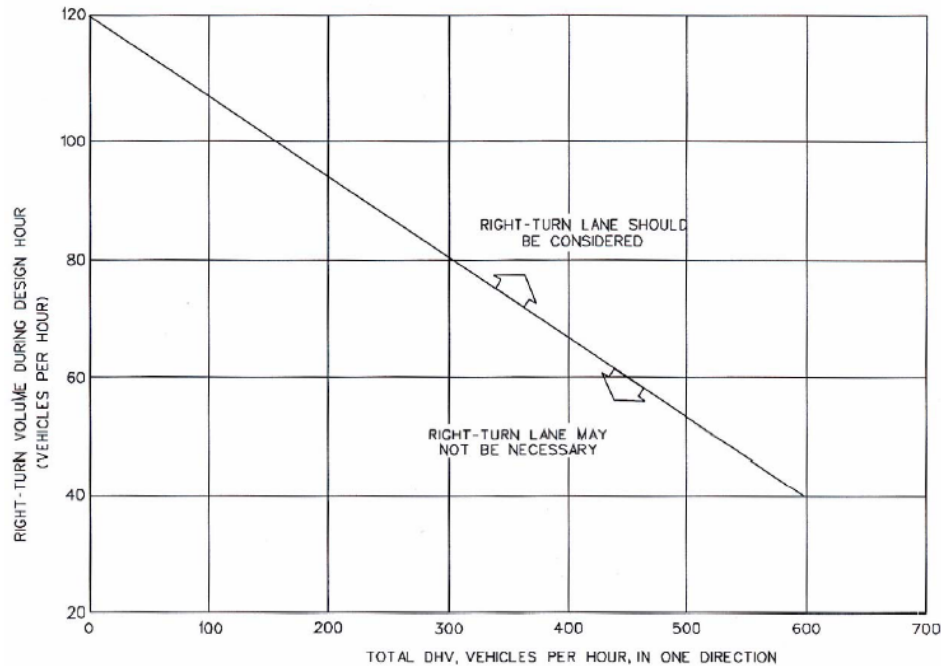
Based on the results in Table 2-8 and Table 2-9, it can be found that:

- The right-turn design hour volume that warrants a right-turn treatment is lower on highways with higher directional design hour volumes and higher operational speed.
- The right-turn design hour volume required to justify a right-turn treatment on a two-lane highway is lower than that on a four-lane highway.

DeBaie (2004)

DeBaie (2004) reviewed the concepts, standards, and applications of turn lanes on unsignalized intersections. For the right-turn lanes, it was found that:

- Both the AASHTO Green Book and the TRB HCM (1994) suggested that when the hourly right-turn volume exceeds 300 vph, a right-turn lane should be considered.
- Most states include a graph in their design manuals for determining warranting volumes for right-turn lanes at unsignalized intersections (see Figure 2-19).

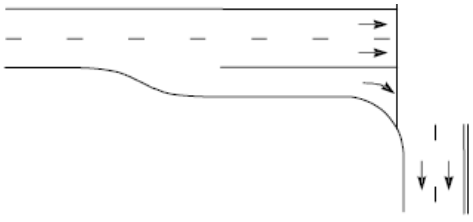


**Figure 2-19. Typical State Design Manual Guideline for Right-Turn Lanes at Unsignalized Intersections on Two-Lane Highways.**  
*Source: DeBaie (2004)*

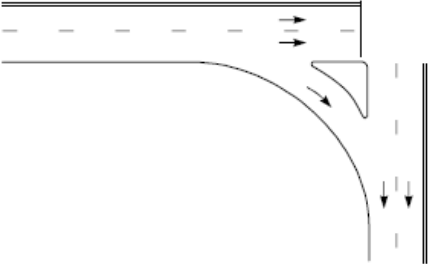
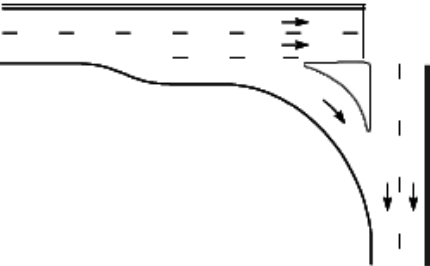
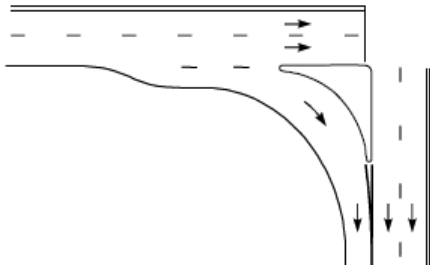
*Fitzpatrick and Schneider (2004)*

According to this report, there are four common configurations for right-turn lanes. These configurations along with their advantages and disadvantages are shown in Table 2-10. Figure 2-20 illustrates basic right-turn lanes along with key design components.

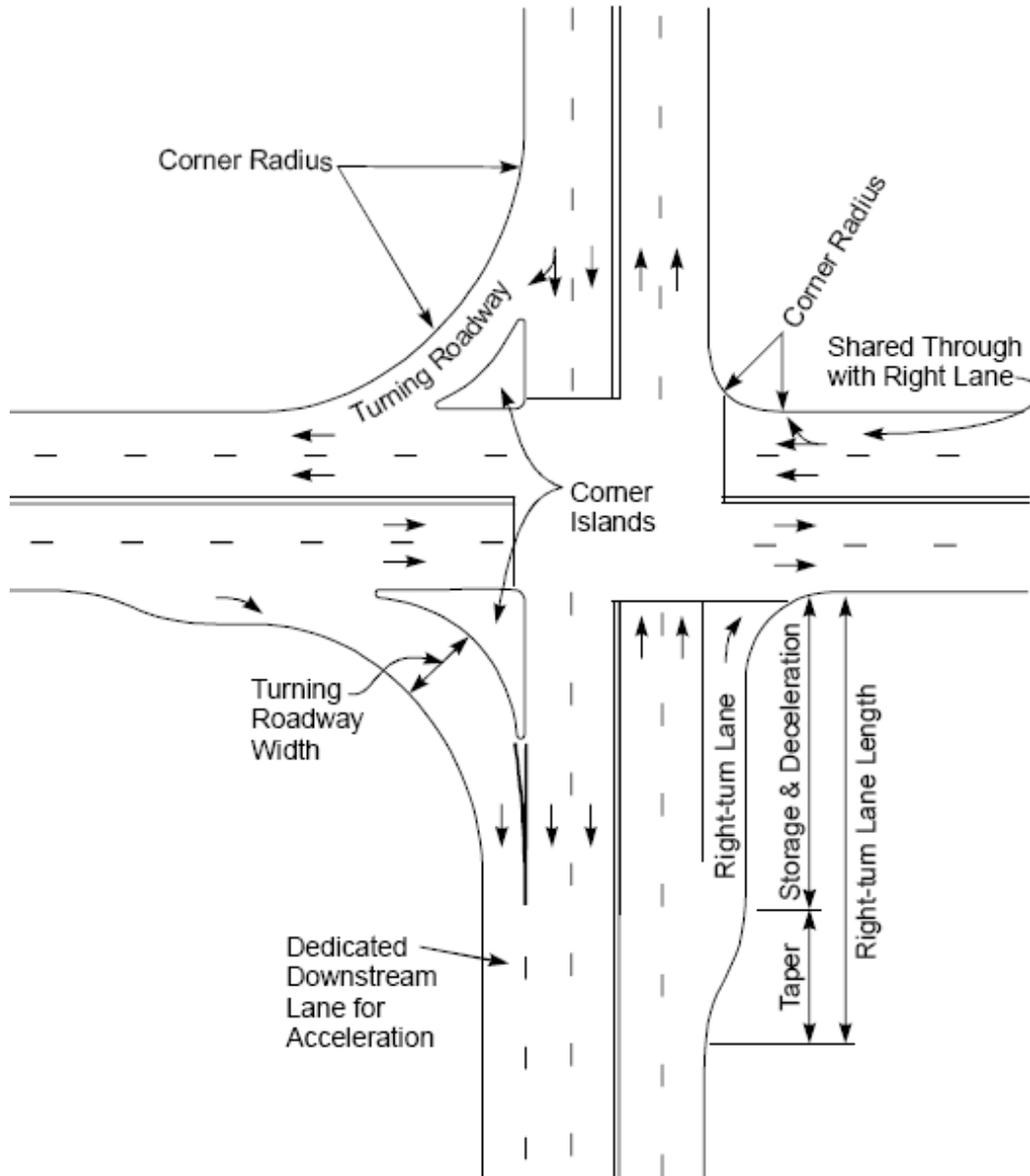
**Table 2-10. Right-Turn Lanes Designs.**

<p style="text-align: center;">Right-Turn Lane with a Lane Line Pavement Marking</p> 	<p><b>ADVANTAGES</b></p> <ul style="list-style-type: none"> <li>• Allows right-turn-on-red (unless prohibited), reducing right-turn queues.</li> <li>• Removes turning vehicles from through-vehicle lane for improved intersection operations.</li> <li>• Lower turning speeds provide a safer pedestrian environment.</li> </ul> <p><b>DISADVANTAGES</b></p> <ul style="list-style-type: none"> <li>• All vehicles must stop on red, potentially increasing the right-turn queue.</li> <li>• The absence of an island eliminates its use for placement of traffic control devices and a pedestrian refuge.</li> </ul>
--	---

**Table 2-10. Right-Turn Lanes Designs.**

<p>Shared Lane with Island (also called Slip Ramp or Free-Flow Right-Turn)</p> 	<p><b>ADVANTAGES</b></p> <ul style="list-style-type: none"> <li>• Provision of islands permits its use for placement of traffic control devices or as a pedestrian refuge.</li> <li>• Removes turning vehicle from head of queue.</li> </ul> <p><b>DISADVANTAGES</b></p> <ul style="list-style-type: none"> <li>• May encourage higher motorist speeds, which may present a hazard to pedestrians.</li> <li>• If signal support is located on island, pedestrians will need to cross uncontrolled lane to reach pedestrian push button.</li> <li>• The through movement queue may obstruct the throat of the right-turn lane, reducing capacity of the intersection.</li> <li>• Driver attention is split between looking back to merging traffic and looking forward to pedestrian crossing points that may be present in front of the vehicle.</li> </ul>
<p>Right-Turn Lane with Island (also called Channelized Right-Turn Lane or Free-Flow Right-Turn)</p> 	<p><b>ADVANTAGES</b></p> <ul style="list-style-type: none"> <li>• Provides relatively free movement for vehicles after yielding to pedestrians and opposing traffic, thus reducing right-turn queues, lowering emissions, and increasing capacity.</li> <li>• Provision of islands permits its use for placement of traffic control devices or as a pedestrian refuge.</li> <li>• Removes turning vehicles from through-vehicle lane for improved intersection operations.</li> </ul> <p><b>DISADVANTAGES</b></p> <ul style="list-style-type: none"> <li>• Same as Shared Lane with Island.</li> </ul>
<p>Right-Turn Lane with Island and Dedicated Downstream Lane</p> 	<p><b>ADVANTAGES</b></p> <ul style="list-style-type: none"> <li>• Provides relatively free movement for vehicles after yielding to pedestrians, thus reducing right-turn queues, lowering emissions, and increasing capacity.</li> <li>• Provision of islands permits its use for placement of traffic control devices or as a pedestrian refuge.</li> <li>• Eliminates need to look for merging vehicles (attention may be focused ahead of vehicle because driver is entering dedicated lane).</li> </ul> <p><b>DISADVANTAGES</b></p> <ul style="list-style-type: none"> <li>• Same as Shared Lane with Island. Vehicles are observed to frequently stop prior to entering the cross street even with an available dedicated lane, because drivers do not know they have a dedicated lane or its length.</li> <li>• Dedicated downstream lane must be sufficient length for vehicles to merge.</li> <li>• Access needs to be managed along dedicated downstream lane to ensure proper operation.</li> </ul>

Source: Fitzpatrick and Schneider (2004)



**Figure 2-20. Right-Turn Lane and Right Turning Roadway Examples.**

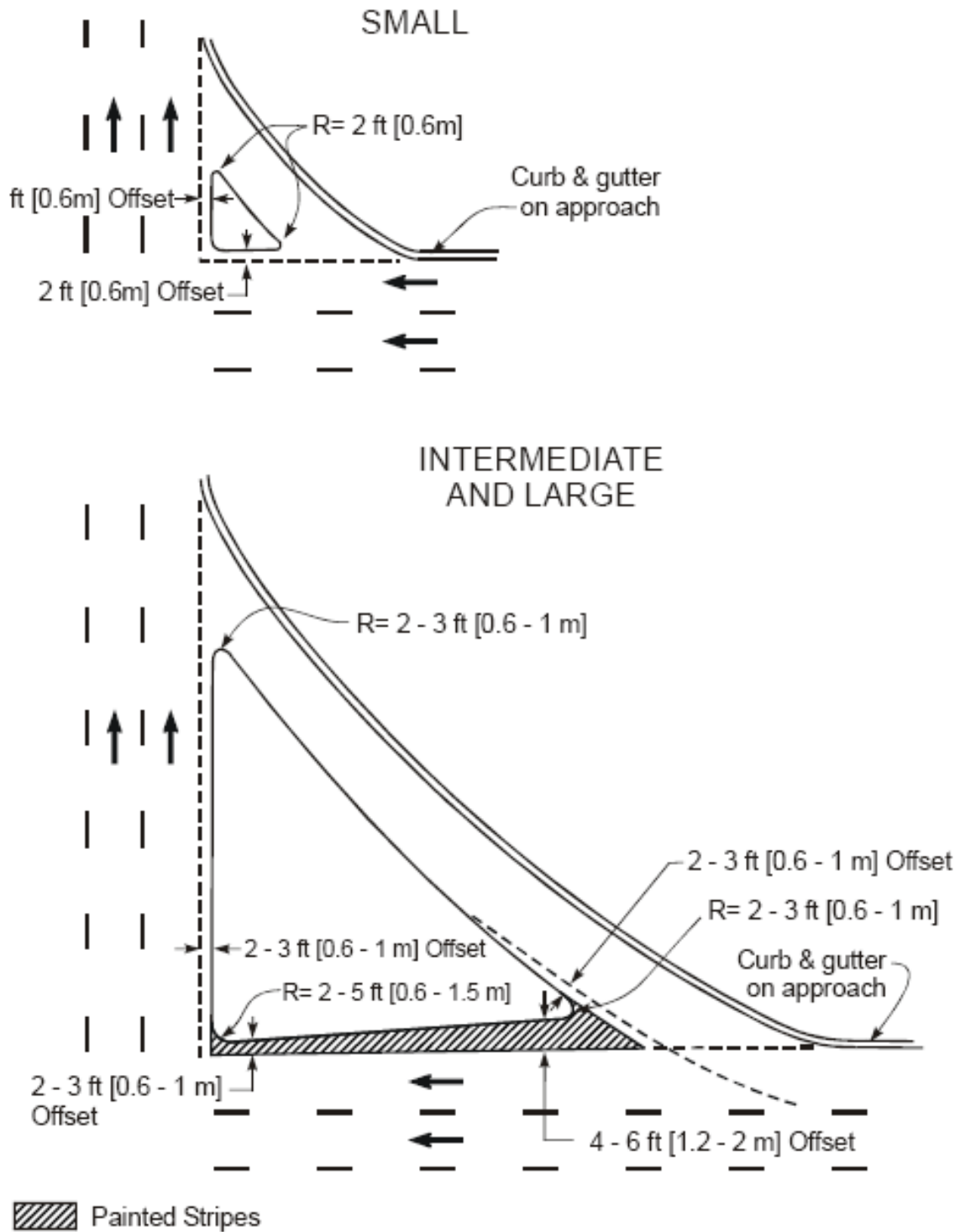
*Source: Fitzpatrick and Schneider (2004)*

The following are recommendations for the key elements in the design of right-turn lanes:

- *Design vehicles:* When developing an intersection design, one should consider occasional vehicles (i.e., moving vans) as well as the predominant vehicle (i.e., passenger car).
- *All users:* When developing an intersection design, one should not only consider the motorized vehicles, but also consider the pedestrians and bicyclists. Pedestrians can influence the selection of radius, the presence of an island, the appropriate location for the curb ramp, the location of the crosswalk, and whether traffic signal equipment is present and where it is located. Bicycles can influence the pavement markings.

- *Length*: Both the right-turn and through-movement queues should be reviewed when establishing the length of the right-turn lane, which includes the entering taper, deceleration length, and storage length.
- *Radius*: The design of the corner radius affects both the drivers (the speeds and the path the driver follows) and the pedestrians (their path and dealing with the speed of the turning vehicle). For different design vehicles, different curb radii are recommended:
  - For passenger cars: 15 ft to 25 ft.
  - For heavy volumes of trucks or buses: 40 ft to 50 ft.
  - The benefit of a larger radius:
    - Accommodates larger vehicles without encroachment.
    - Permits higher turning-vehicle speeds in free-flow situations that can produce smaller-speed differentials with following vehicles and thus less severe rear-end conflicts.
    - May allow the presence of islands for traffic control devices and pedestrian refuge areas.
  - The benefit of a smaller radius:
    - Reduced vehicle crossing time.
    - Reduced pedestrian crossing time that leads to reduced vehicular delay at signalized intersections.
    - Reduced turning speeds can benefit pedestrians.
    - Reduced pavement area.
- *Corner islands*: The details of corner island designs for turning roadways are presented in Figure 2-21.
  - The minimum area for the curbed corner islands should be 50 ft<sup>2</sup>; 100 ft<sup>2</sup> is preferred.
  - If a cut through the island is planned to accommodate pedestrians, the cut must have a minimum 5 ft width.
  - If curb ramps are used, there must be a minimum 5 ft × 5 ft landing provided on the island. The landing area, combined with a maximum curve ramp slope of 1:12, means that ramped islands are only feasible where the median or island width in the area of the cut is at least 17 ft.
- *Turning roadway widths*.
  - Turning roadway widths should be at least 14 ft and allow turning vehicles to keep their wheel tracks within the traveled way by about 2 ft on both sides.
  - If large trucks are used as design vehicles, this may result in undesirably wide lanes that may encourage passenger cars to use the facility as if it had two lanes. To discourage this behavior, paint or other flush markings may be used to delineate the desired path.
  - For a right-turn at a 90-degree intersection with a minimum-size island, a 60 ft radius on the outer edge provides a 14 ft turn lane.





**Figure 2-21. Details of Corner Island Designs for Turning Roadways (Urban Locations).**

*Source: AASHTO (2001)*

**Current Practice**

In 1981, Cottrell conducted a survey to obtain information about the criteria currently used in selecting road designs to accommodate right-turning vehicles on rural roads from 48 contiguous state DOTs and 41 state DOTs responded. It was found that 16 (39 percent) of the surveyed state DOTs used specific criteria to assess the need for right-turn treatments:

- Five states used warrants based on volume conditions.
- States used warrants based on roadway type.
- Two states used warrants based on capacity.
- States used various rules-of-thumb.

The detail warrants for right-turn lanes are listed in Table 2-11.

**Table 2-11. Warrants for Right-Turn Lanes Used by State DOTs.**

Category	Warrants for Right-Turn Lanes	State	Reference
Volume based	Right-turn volume > 200 vpd	Colorado	Cottrell (1981)
	2-lane road if right-turn volume > 60 vph	Illinois	
	Right-turn volume > 50 vph	Indiana	
	Right-turn volume > 600 vpd	Michigan	
	Right-turn volume = 30 to 60 vph	New Hampshire	
	Right-turn DHV* >50 vph	Vermont	
	Right-turn DHV > 250 and through DHV > 500 **	West Virginia	
Roadway type based	For all high speed 2-lane roads	California	
	For FAS roads, except those with very low vph	Kansas	
	Based on traffic and roadway types	North Dakota	
	For all 4-lane highways where sign route turn	Ohio	
Capacity based	Based on capacity analysis	New York	
	Through volume > 600 vph	Oregon	
Use various rules of thumb	Right-turn vehicle percent > 20 %	Connecticut	
	Based on conflict tables and total DHV	Idaho	
	Exposure index	Iowa	

\* DHV: design hourly volumes

\*\* For divided highways only

**Summary of Existing Warrants and Guidelines for Right-Turn Lanes**

This section reviews the existing warrants for right-turn lanes and the guidelines on right-turn lane design. Table 2-12 summarizes the existing warrants. The existing guidelines include the guidelines on using different types of right-turn lane configurations and the key elements in the design of right-turn lanes.

**Table 2-12. Summary of Existing Warrants for Right-Turn Lanes.**

Warrants for Right-Turn Lanes			Reference
Right-turn lanes are warranted on high speed and on high volume highways where a change in speed is necessary for vehicles entering or leaving the through traffic lanes			AASHTO (1994)
When DHV of right-turns into the access < 5 VPH	When speed limit = 45 to 55 mph	Right-turn lanes are warranted when the outside lane DHV > 250 vph	Oregon State University (1996)
	When speed limit = 35 to 40 mph	Right-turn lanes are warranted when the outside lane DHV > 450 vph	
	When speed limit = 25 to 30 mph	Right-turn lanes are warranted when the outside lane DHV > 600 vph	
Speed limit = 25 to 40 mph	Right-turn lanes are warranted when access DHV $\geq$ 25 vph		
Speed limit > 40 mph	Right-turn lanes are warranted when access DHV $\geq$ 20 vph		
Right-turn volume and adjacent through lane volume each exceed 300 vphpl			HCM (1994)
See Figure 2-15 (the area labeled “full width lane” indicates combinations of peak hour right-turn and total peak hour traffic volumes that are suitable for right-turn lanes)			Cottrell (1981)
See Table 2-8, Table 2-9			Hasan et al. (1996)

## 2.4 STATE-OF-THE-PRACTICE SUMMARY

This task reviewed the literature associated with the design and operation of triple left-turn lanes and right-turn lanes in three aspects:

- The operational studies.
- Safety studies.
- Existing warrants and guidelines.

The operational studies provide the useful information about the operational efficiencies of triple left-turn lanes and right-turn lanes (such as saturation flow rates and speed) and the influencing factors on their operational efficiencies.

The existing safety studies did not find that triple left-turn lanes caused higher crash rates and more severe crashes compared to the single and double left-turn lanes at the same intersections. It was also suggested that properly designed triple left-turn lanes might result in similar crash rates as those of double left-turn lanes.

The existing warrants specified the inappropriate and appropriate situations for installing triple left-turn lanes and right-turn lanes. The most important criterion for installing triple left-turn lane is high left-turn volume (more than 600 vph). Safety, geometric and ROW-based warrants should also be considered in determining the installation of triple left-turn lanes. The warrants for right lanes mainly focus on the right-turn volume. Different right-turn volume criteria were proposed for the intersections with different speed limits.

The existing guidelines for triple left-turn lanes consist of guidelines on geometric design, left-turn lane operational analysis, and traffic signal control. Existing guidelines for right-turn lanes

include the guideline on using different types of right-turn lane configurations and the key elements in the design of a right-turn lane.

## 2.5 REFERENCES

Ackeret, K. W. Criteria for the Geometric Design of Triple Left-Turn Lanes, *ITE Journal, Institute of Transportation Engineers*, Vol. 64 No. 12, pp. 27–33, December 1994. Online: [http://turnlanes.net/files/criteria\\_for\\_the\\_geometric\\_design\\_of\\_triple\\_left-turn\\_lanes.pdf](http://turnlanes.net/files/criteria_for_the_geometric_design_of_triple_left-turn_lanes.pdf). Link Accessed October 25, 2010.

Ackeret, K. W. Analysis of Saturation Flows at Single, Dual and Triple Left-Turn Lanes. Ph.D. dissertation. University of Nevada, Las Vegas, May 1996. Online: <http://turnlanes.net/files/Analysisofsaturationflowsatsingledualandtripleleft-turnlanes.pdf>. Link Accessed October 25, 2010.

Ackeret, K.W., R. Menon, and S. S. Nambisan. Evaluation of Sideswipe Crashes at Triple and Dual Left-Turn Lanes in Las Vegas, Nevada. Presented at the 69th Annual Meeting of the Institute of Transportation Engineers, Las Vegas, Nevada, 1999.

American Association of State Highway and Transportation Officials (AASHTO), A Policy on the Geometric Design of Highways and Streets, 1990, 1994.

American Association of State Highway and Transportation Officials. A Policy on Geometric Design of Highways and Streets. AASHTO, Washington, D.C., 2001.

Belluccia, A. G., G. L. Harter, and M. J. Rechterik. Triple Left-Turn Lanes: Getting the First One Approved,” Dames & Moore, 1996. Online: <http://turnlanes.net/files/Belluccia%20Triple%20Left-Turn%20Lanes%20%20Getting%20the%20First%20One%20approved.pdf>. Link Accessed October 25, 2010.

Cottrell, B.H. *The Development of Criteria for the Treatment of Right Turn Movements on Rural Roads*. Publication Final Rept. VHTRC 81-R45. Virginia Highway and Transportation Research Council, Charlottesville, VA, March 1981. Online: [http://www.virginiadot.org/vtrc/main/online\\_reports/pdf/81-r45.pdf](http://www.virginiadot.org/vtrc/main/online_reports/pdf/81-r45.pdf). Link Accessed October 25, 2010.

Courage K., B. Stephens, A. Gan, and M. Willis. *Triple Left-Turn Lanes at Signalized Intersections*, Publication Research Report for Florida Department of Transportation, December 2002. Online: [http://www.dot.state.fl.us/research-center/Completed\\_Proj/Summary\\_TE/FDOT\\_BC131rpt.pdf](http://www.dot.state.fl.us/research-center/Completed_Proj/Summary_TE/FDOT_BC131rpt.pdf). Link Accessed October 25, 2010.

DeBaie D. J. Turn Lane Warrants: Concepts, Standards, Application in Review. ITE Annual Meeting, 2004. Online: <http://turnlanes.net/files/David%20DeBaie%20Paper.pdf>. Link Accessed October 25, 2010.

Dixon, K. K., J. L. Hibbard, and H. Nyman. Right-Turn Treatment for Signalized Intersections. Urban Street Symposium, Transportation Research Circular E-C019, 1999. Online: [http://turnlanes.net/files/Right-Turn\\_Treatment\\_for\\_Signalized\\_Intersections.pdf](http://turnlanes.net/files/Right-Turn_Treatment_for_Signalized_Intersections.pdf). Link Accessed October 25, 2010.

Fitzpatrick, K., and W. H. Schneider. *Turn Speeds and Crashes Within Right-Turn Lanes*. Publication Technical Report FHWA/TX-05/0-4365-4: September 2001-August 2004, Texas Transportation Institute, the Texas A&M University System. Online: <http://tti.tamu.edu/documents/0-4365-4.pdf>. Link Accessed October 25, 2010.

Hasan T., and R.W. Stokes. *Guidelines for Right-Turn Treatments at Unsignalized Intersection and Driveways*. Publication Report No. K-TRAN: KSU 95-5, May 1996. Online: <http://www.ksdot.org/PublicLib/doccontent.dll?LibraryName=PublicDocs^dt00mx38&SystemType=2&LogonId=a3d70adcf1f2b89f1e6863c09693bbae&DocId=003670396>. Link Accessed October 25, 2010.

Harwood, D.W., D. J. Torbic, K. R. Richard, and L. Elefteriadou. *Review of Truck Characteristics as Factors in Roadway Design*. Publication NCHRP Report 505, Transportation Research Board. 2003. Online: [http://onlinepubs.trb.org/onlinepubs/nchrp/nchrp\\_rpt\\_505.pdf](http://onlinepubs.trb.org/onlinepubs/nchrp/nchrp_rpt_505.pdf). Link Accessed October 25, 2010.

*Highway Capacity Manual*. Transportation Research Board, Washington, D.C., 2004.

ITE Technical Council Committees 5P-5 and 5P-1. Capacities of Double and Triple Left-Turn Lanes. ITE Compendium of Technical Papers, Institute of Transportation Engineers, 1995. Online: <http://turnlanes.net/files/ITE%20Tech%20Council%20Capacities%20of%20Triple%20LT%20Lanes.pdf>. Link Accessed October 25, 2010.

Leonard, J. D. Operational Characteristics of Triple Left Turns. In *Transportation Research Record: Journal of the Transportation Research Board, No. 1457*, Transportation Research Board of the National Academies, Washington, D.C., 1994.

Mitchell, R. Tracking the Rise of the Triple Left-Turn. Compendium of Technical Papers, Institute of Transportation Engineers, pp. 271–276, 1993.

Oregon State University. Right-Turn Lanes, Discussion Paper 11, prepared for the Oregon Department of Transportation, Oregon, May 1996. Online: <http://www.oregon.gov/ODOT/HWY/ACCESSMGT/docs/RightTurnLanes.pdf?ga=t>. Link Accessed October 25, 2010.

Qureshi, M., G. Spring, V. R. Malkayigari, and J. Rathod. Assessment of Multiple Left-Turn Phasing Strategies. Publication Report No. RDT 04-003, Missouri Department of Transportation, January 2004. Online: <http://library.modot.mo.gov/RDT/reports/Ri02014/brief.pdf>. Link Accessed October 25, 2010.

Sando, T., and R. N. Mussa. Site Characteristics Affecting Operation of Triple Left-Turn Lanes, *Transportation Research Record*, No. 1852, 2003. Online: [http://turnlanes.net/files/TRR1852\\_2.pdf](http://turnlanes.net/files/TRR1852_2.pdf). Link Accessed October 25, 2010.

Shen, Q., Minimum Merging Section Lengths for Triple Left-Turns with Downstream Lane Reductions. *ITE Journal*, pp. 40–45, March 2001.

Texas Department of Transportation. *Roadway Design Manual*. Revised May 2010. Online: <http://onlinemanuals.txdot.gov/txdotmanuals/rdw/rdw.pdf>. Link Accessed October 25, 2010.

Transportation Research Board, *Highway Capacity Manual*. Washington, D.C. 1994

Yu, L., Y. Qi, M. Azimi, C. Guo and L. Guo, *Left-Turn Lane Design and Operation*. Publication Research Report TxDOT 0-5290-1, Texas Department of Transportation, August 2007. Online: [http://transportation.tsu.edu/Reports/TxDOT\\_5290-1.pdf](http://transportation.tsu.edu/Reports/TxDOT_5290-1.pdf). Link Accessed October 25, 2010.

Yu L., Y. Qi, H. Yu, L. Guo and C. Chen. *Development of Left-Turn Operations Guidelines at Signalized Intersections*. Publication Report No. TxDOT 0-5840-1, final report to Texas Department of Transportation (TxDOT), 2008.

## **CHAPTER 3**

### **STATE AND NATIONAL SURVEY ON MULTIPLE TURN LANES**

#### **3.1 SURVEY DESIGN AND DISTRIBUTION**

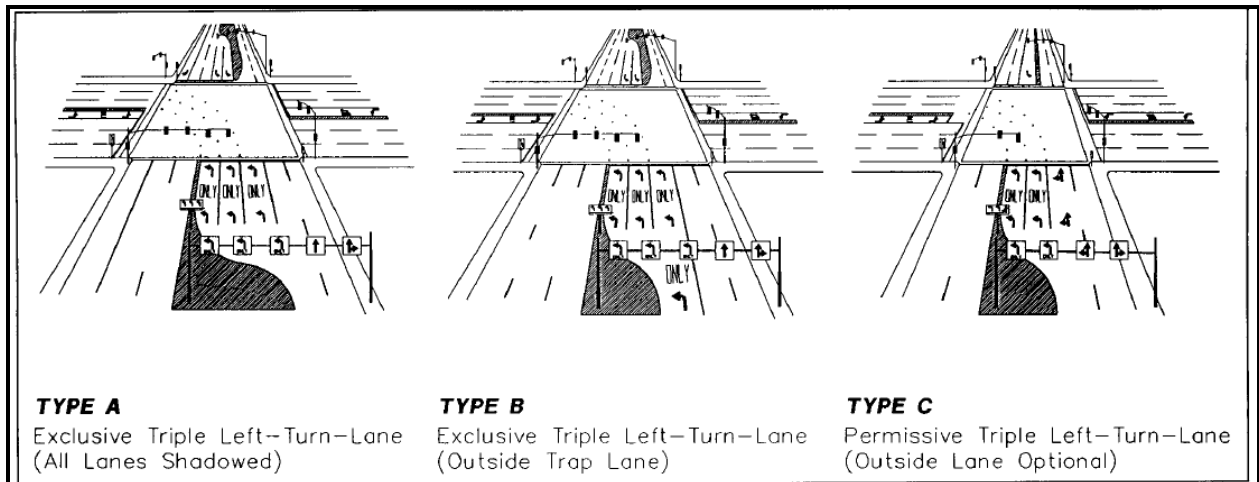
The research team prepared the survey instrument to collect information about design and operations of triple left-turn and dual right-turn lanes around the country. Several of the past studies were used as a guideline to design the survey questions. The survey had two major categories: triple left-turn lanes and dual right-turn lanes. The survey was accessible from the project website and was also available in a downloadable format.

The project monitoring committee members reviewed the survey and provided some invaluable suggestions that were implemented in the survey to get it ready for distribution. The distribution list for the national survey was prepared using the list of AASHTO rosters and by using the information obtained during the literature review and internet sources. The national survey was sent out through email to 49 state DOTs and 75 cities nationwide. The state survey was distributed to all 25 TxDOT districts and 27 cities in Texas.

#### **3.2 STATE SURVEY RESULTS**

##### **Triple Left-Turn Lanes**

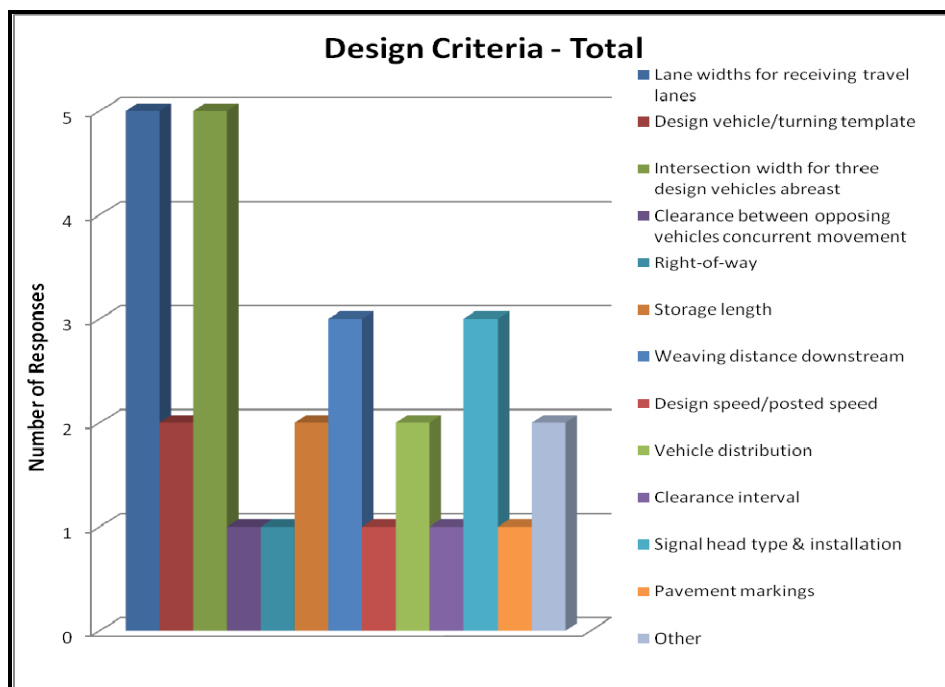
- *General Information:*
  - Five agencies out of 30 (TxDOT districts and cities) have triple left-turn lanes.
    - El Paso – TxDOT District.
    - Houston – TxDOT District.
    - City of Arlington – temporary game day setup.
    - City of Houston.
    - City of Garland.
  - None of the agencies have existing guidelines/best practices that served as guidelines for the triple left-turn installations.
  - All five agencies use protected-only phasing for triple left-turn installations.
  - Two agencies performed studies to evaluate triple left-turn installations.
    - El Paso – TxDOT District.
    - City of Garland.
- *Number and Type of Location as shown in Figure 3-1:*
  - Total number of installations from all 5 respondents – 6.
  - Type of installation.
    - Type A – 1.
    - Type B – 1.
    - Type C – 2.
    - Other – 2.



**Figure 3-1. Three Types of Triple Left-Turn Implementation.**

- *Design Criteria.*

Figure 3-2 shows the frequency of selection for each design criteria by the survey respondents.

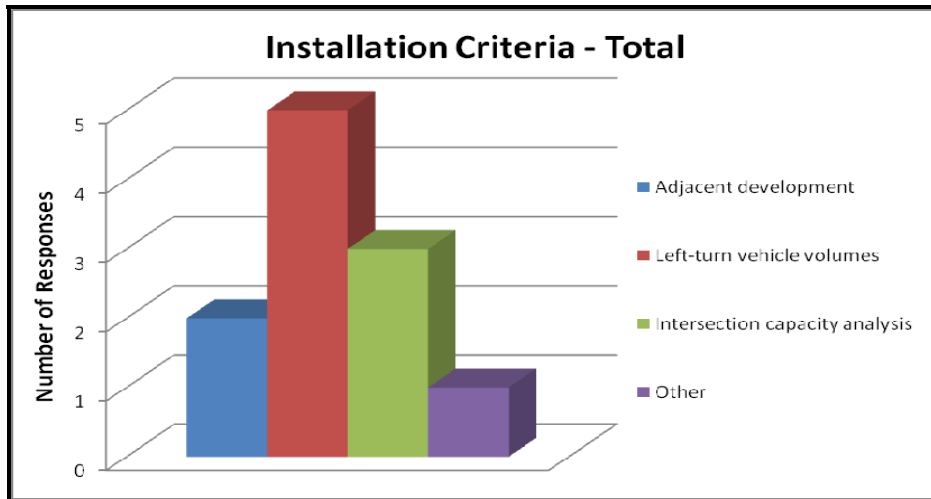


**Figure 3-2. Design Criteria for Triple Left-Turn Installations (State Survey).**

- *Installation Criteria.*

Figure 3-3 shows the frequency of selection for each installation criteria by the survey respondents.

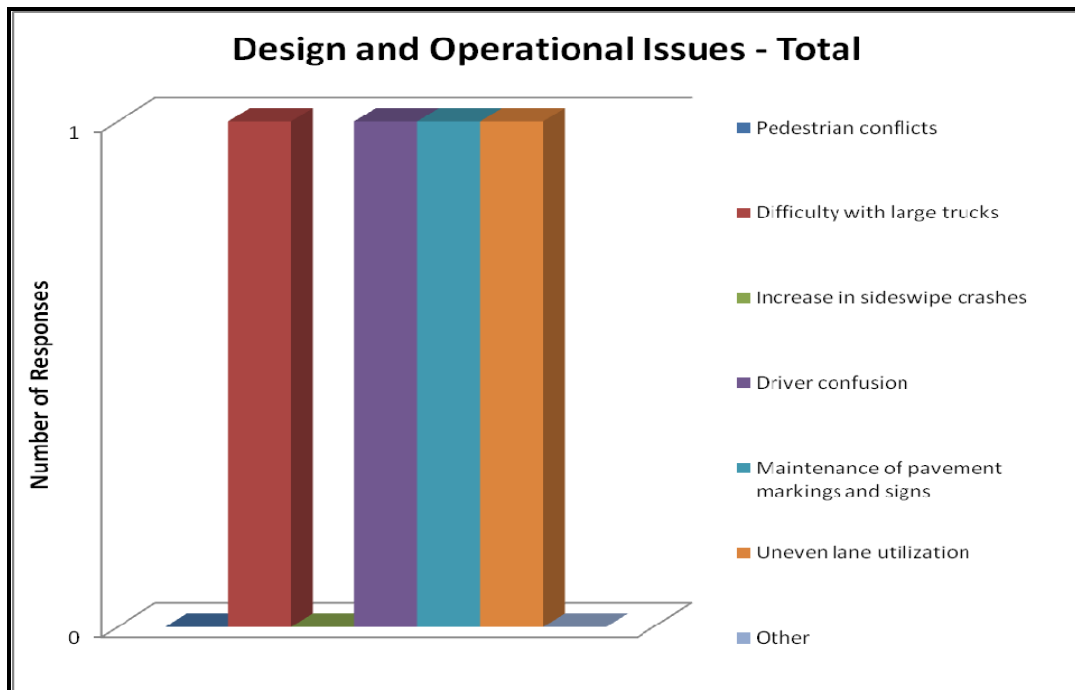




**Figure 3-3. Installation Criteria for Triple Left-Turn Installations (State Survey).**

- *Design and Operational Issues.*

The survey respondents were asked to select all the design and operational issues that were applicable to the triple-left turn site design from the provided list. Figure 3-4 shows the frequency of selection for each of these issues.



**Figure 3-4. Design and Operational Issues for Triple Left-Turn Installations (State Survey).**

- *Most Important Factors in Design and Operation of Triple Left-Turn Lanes.*

The survey respondents were asked to rate the list of seven factors based on their importance in the design and operation of triple left-turn lanes. The following is a list of factors in decreasing order of importance according to the survey results (1 = most important, 7 = least important).

- Left-turn volume.
- Traffic and geometric conditions upstream and downstream.
- Storage length.
- Selection of design vehicles.
- Intersection angle.
- Sight distance.
- Intersection grade.

### **Dual Right-Turn Lanes**

- *General Information:*

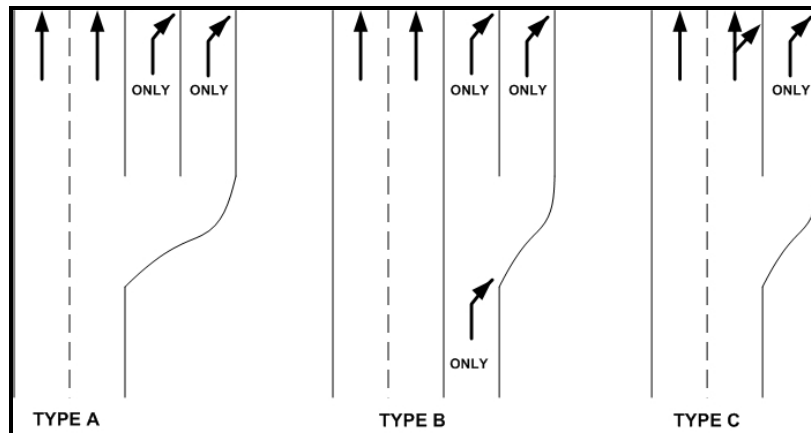
- Sixteen agencies out of 30 (TxDOT districts and cities) have dual right-turn lanes.
- Three out of 16 agencies have existing guidelines/best practices that served as guidelines for the dual right-turn installations.
  - Laredo – TxDOT district.
  - City of Pasadena.
  - City of Mesquite.
- RTOR (right-turn on red).
  - Allowed from both right-turn lanes – 9 respondents.
  - Allowed for only outside right-turn lane – 4 respondents.
  - Not allowed – 2 respondents.
- Eight agencies performed studies to evaluate dual right-turn installations.
  - City of Pasadena.
  - City of Garland.
  - City of Mesquite.
  - City of Grand Prairie.
  - San Angelo – TxDOT district.
  - Laredo – TxDOT district.
  - Waco – TxDOT district.
  - Houston – TxDOT district.

- *Number of Locations and Type of Location:*

The survey respondents were asked to provide information about any existing/proposed dual right-turn installations in their area. The respondents were also asked to select the type of installation (from the type of installations shown in Figure 3-5) and provide explanation if the type of installation in their area is different from what is shown.

- Total number of installations from all the 16 respondents – 25 (1 installation with all three types).

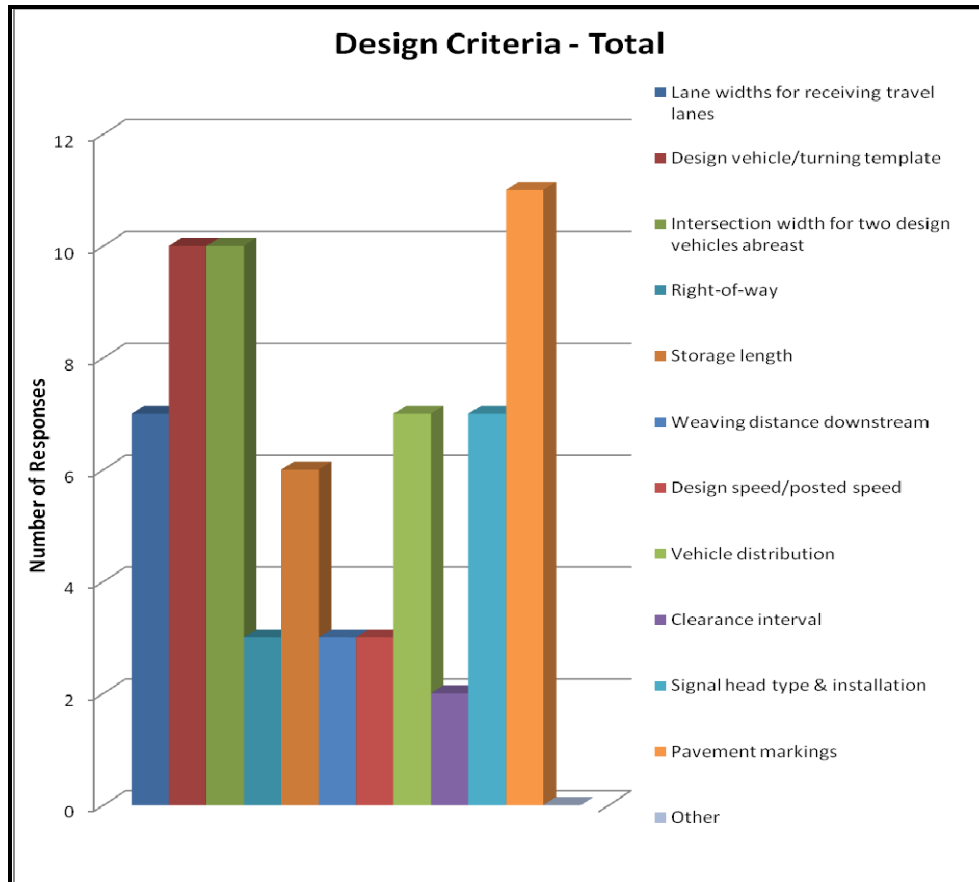
- Type of installation.
  - Type A – 1.
  - Type B – 5.
  - Type C – 18.
  - Other – 3.



**Figure 3-5. Three Types of Dual Right-Turn Implementation.**

- *Design Criteria.*

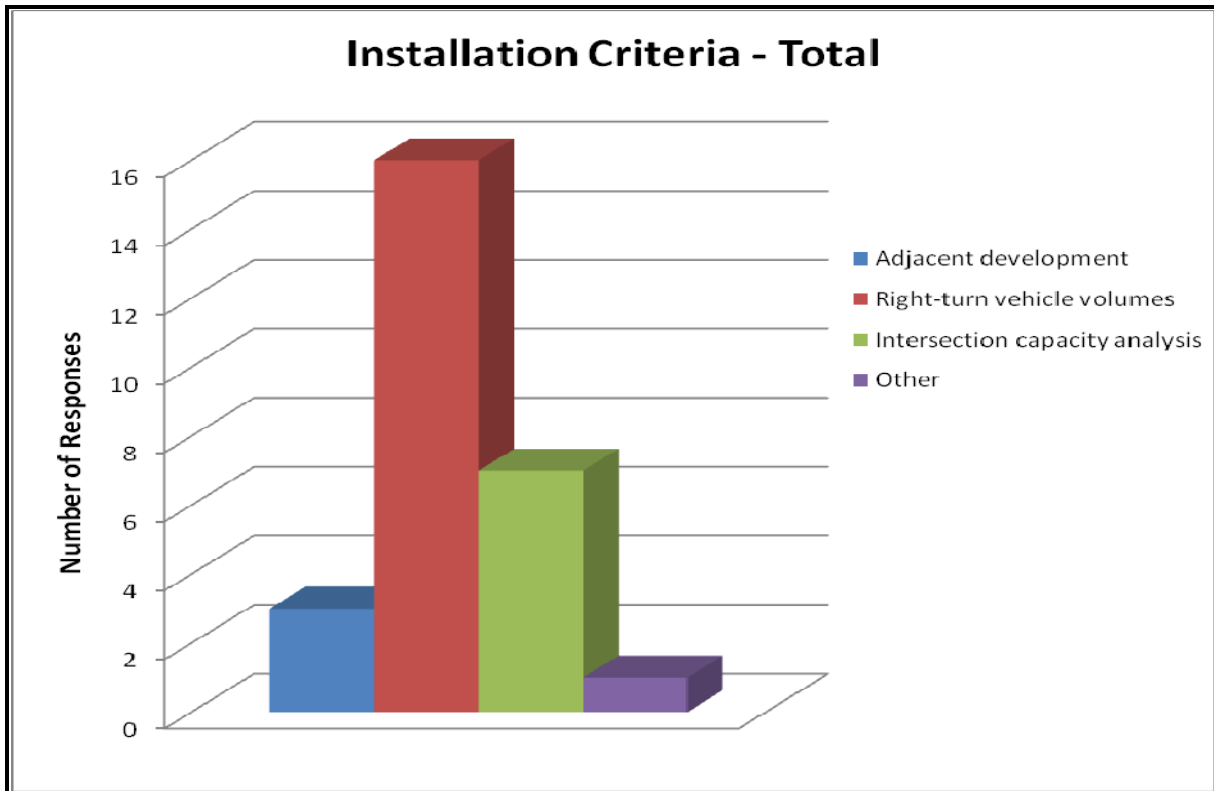
The survey respondents were asked to select all the design criteria that were applicable to the dual right-turn site design from the provided list. Figure 3-6 shows the frequency of selection for each design criterion.



**Figure 3-6. Design Criteria for Dual Right-Turn Installations (State Survey).**

- *Installation Criteria.*

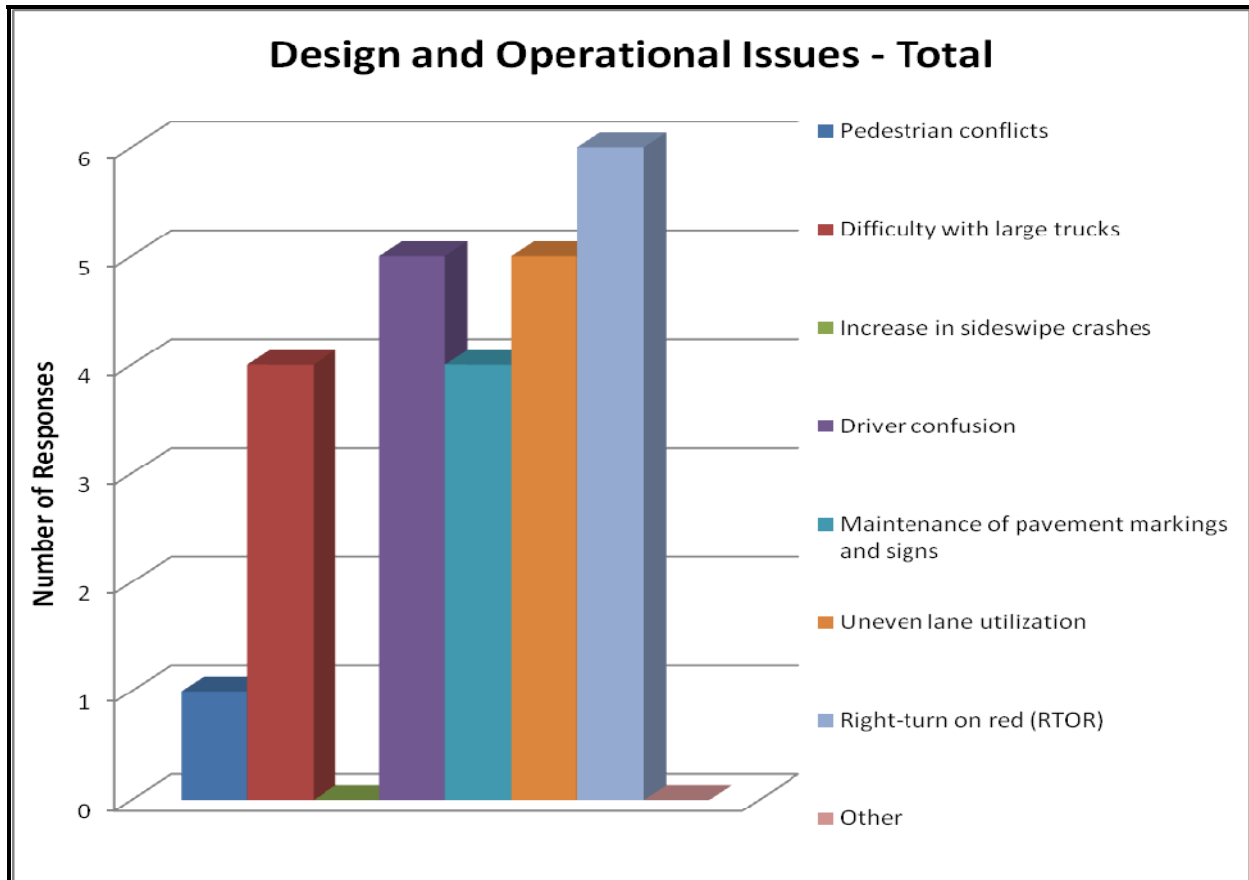
Figure 3-7 shows that *right-turn vehicle volumes* along with the *intersection capacity analysis* were the top two criteria for dual right-turn implementations according to the survey respondents.



**Figure 3-7. Installation Criteria for Dual Right-Turn Installations (State Survey).**

- *Design and Operational Issues*

Figure 3-8 shows the design and operation issues that the survey respondents faced for the dual right-turn installations.



**Figure 3-8. Design and Operational Issues for Dual Right-Turn Installations (State Survey).**

- *Most Important Factors in Design and Operation of Dual Right-Turn Lanes.*

The survey respondents were asked to rate the list of seven factors based on their importance in the design and operation of dual right-turn lanes. The following is a list of factors in decreasing order of importance according to the survey results (1 = most important, 7 = least important).

1. Right-turn volume.
2. Intersection angle.
3. Traffic and geometric conditions upstream and downstream.
4. Storage length.
5. Sight distance.
6. Selection of design vehicles.
7. Intersection grade.

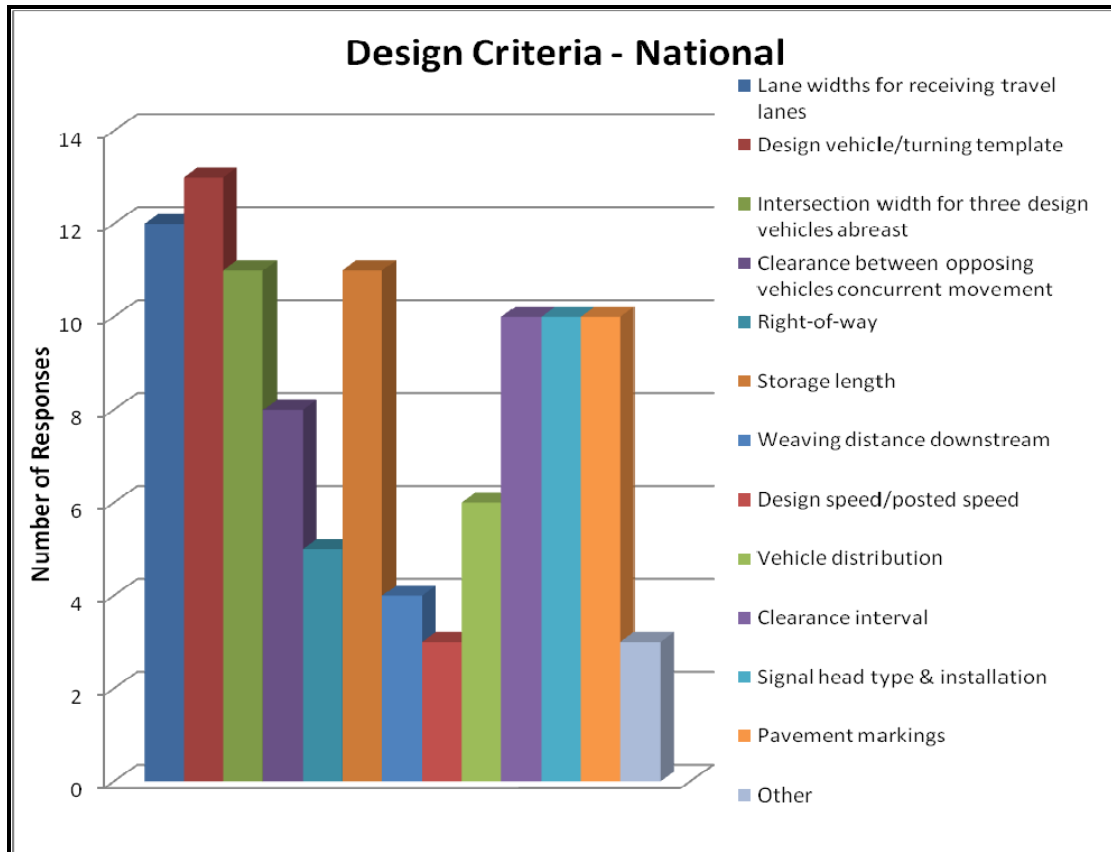
### 3.3 NATIONAL SURVEY RESULTS

#### Triple Left-Turn Lanes

- *General Information:*
  - Eighteen agencies out of 36 (state DOTs and cities) have triple left-turn lanes.
    - Arizona DOT.
    - Washington State DOT.
    - City of Riverside, California.
    - San Francisco Metropolitan Transportation Authority, California.
    - Minnesota DOT.
    - Ohio DOT.
    - Philadelphia Department of Streets/Traffic Engineering, Pennsylvania.
    - City of Sacramento, California.
    - Phoenix Street Transportation Department, Arizona.
    - Mississippi DOT.
    - Delaware DOT.
    - City of Roseville, California.
    - Colorado DOT.
    - Kansas DOT.
    - City of Tucson Department of Transportation, Arizona.
    - City of San Diego, California.
    - City of Dublin, California.
    - City of Greensboro, North Carolina.
- Five out of 18 agencies have existing guidelines/best practices that served as guidelines for the triple left-turn installations.
  - Washington DOT.
  - City of Sacramento, California.
  - Colorado DOT.
  - Kansas DOT.
  - City of San Diego, California.
- Fifteen agencies (two no answer) use protected-only phasing for triple left-turn installations.
- Four agencies performed studies to evaluate triple left-turn installations.
  - Washington DOT.
  - San Francisco Metropolitan Transportation Authority, California.
  - Minnesota DOT.
  - City of San Diego, California.
- *Number of Locations and Type of Location as shown in Figure 3-1:*
  - Total number of installations from all the 17 respondents – 38.
  - Type of installation.
    - Type A – 5.
    - Type B – 12.
    - Type C – 12.
    - Other – 9.

- *Design Criteria.*

The survey respondents were asked to select all the design criteria that were applicable to the triple left-turn site design from the provided list. Figure 3-9 shows the frequency of selection for each design criteria.

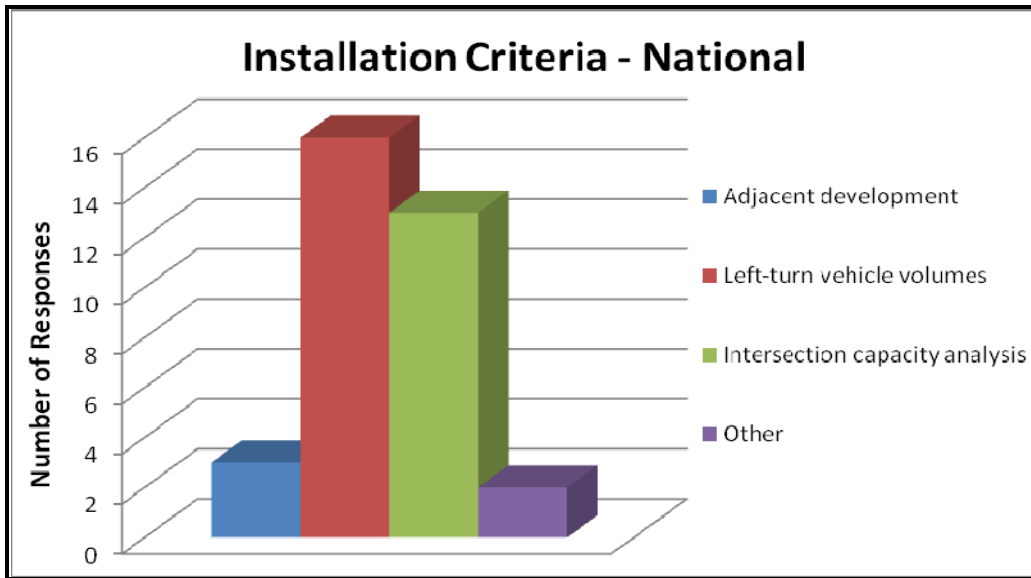


**Figure 3-9. Design Criteria for Triple Left-Turn Installations (National Survey).**

- *Installation Criteria.*

The survey respondents were asked to select all the installation criteria that were applicable to the triple-left turn site design from the provided list. Figure 3-10 shows the frequency of selection for each installation criteria.

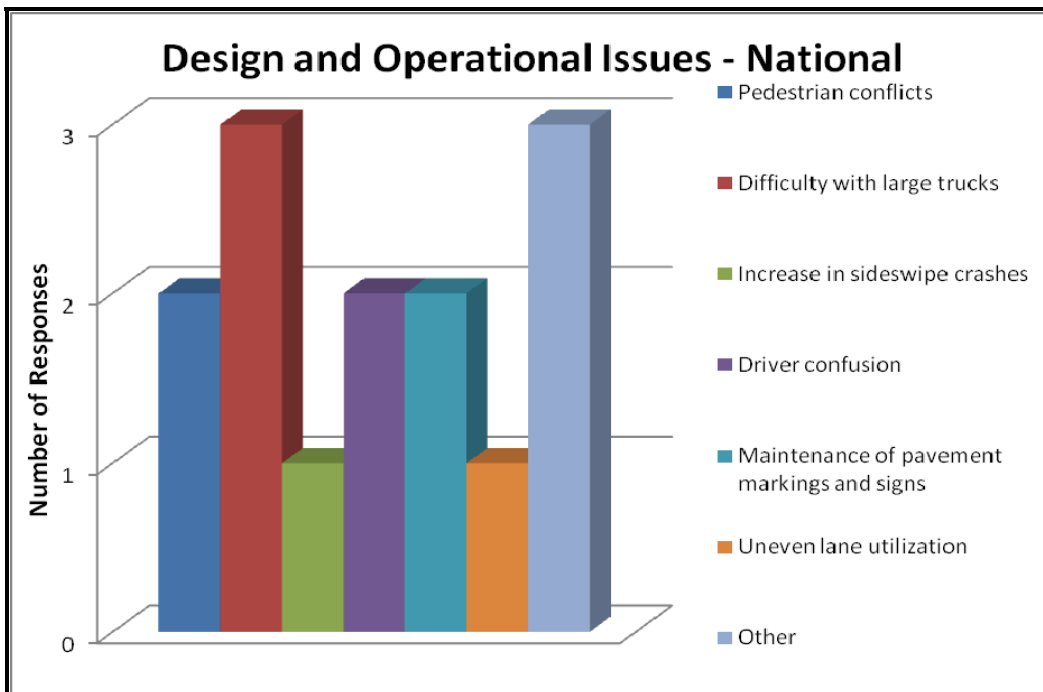




**Figure 3-10. Installation Criteria for Triple Left-Turn Installations (National Survey).**

- *Design and Operational Issues.*

Figure 3-11 shows the design and operation issues that the survey respondents faced for the triple left-turn installations.



**Figure 3-11. Design and Operational Issues for Triple Left-Turn Installations (National Survey).**

- *Most Important Factors in Design and Operation of Triple Left-Turn Lanes.*

The survey respondents were asked to rate the list of seven factors based on their importance in the design and operation of triple left-turn lanes. The following is a list of factors in decreasing order of importance according to the survey results (1 = most important, 7 = least important).

1. Left-turn volume.
2. Traffic and geometric conditions upstream and downstream.
3. Selection of design vehicles.
4. Storage length.
5. Intersection angle.
6. Sight distance.
7. Intersection grade.

### **Dual Right-Turn Lanes**

- *General Information:*

- Thirty-two agencies out of 36 (state DOTs and cities) have dual right-turn lanes.
- Seven out of 32 agencies have existing guidelines/best practices that served as guidelines for the dual right-turn installations.
  - Washington DOT.
  - City of Orlando, Florida.
  - City of Phoenix, Arizona.
  - Illinois DOT.
  - Colorado DOT.
  - Kansas DOT.
  - City of San Diego, California.
- RTOR (right-turn on red).
  - Allowed from both right-turn lanes – 16 respondents.
  - Allowed for only outside right-turn lane – 10 respondents.
  - Not allowed – 3 respondents.
- Six agencies performed studies to evaluate dual right-turn installations.
  - Washington DOT.
  - San Francisco Metropolitan Transportation Authority, California.
  - Minnesota DOT.
  - City of Bellevue, Washington.
  - City of Phoenix, Arizona.
  - Delaware DOT.

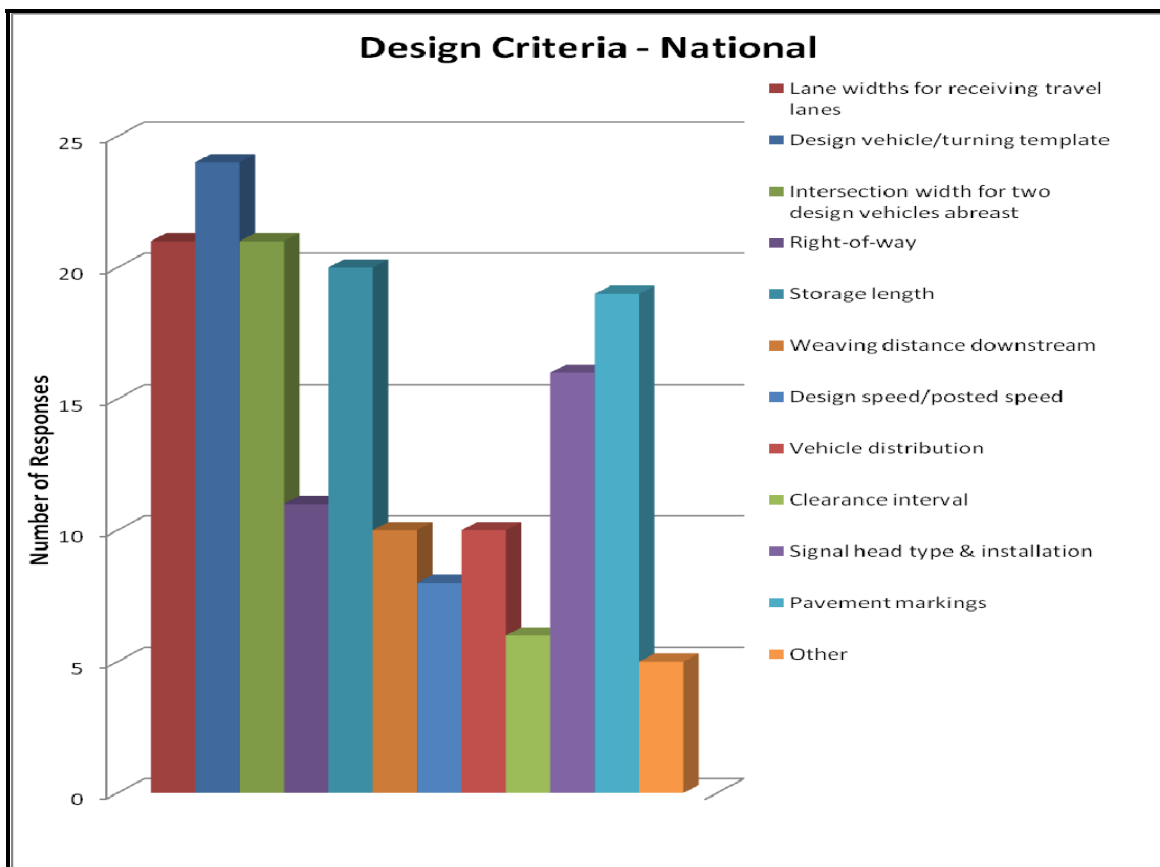
- *Number of Locations and Type of Location:*

The survey respondents were asked to provide information about any existing/proposed dual right-turn installations in their area. The respondents were also asked to select the type of installation (Figure 3-5) and provide explanation if the type of installation in their area is different from what is shown.

- Total number of installations from all the 32 respondents – 90 (1 installation with all three types).
- Type of installation.
  - Type A – 21.
  - Type B – 30.
  - Type C – 37.
  - Other – 4.

- *Design Criteria.*

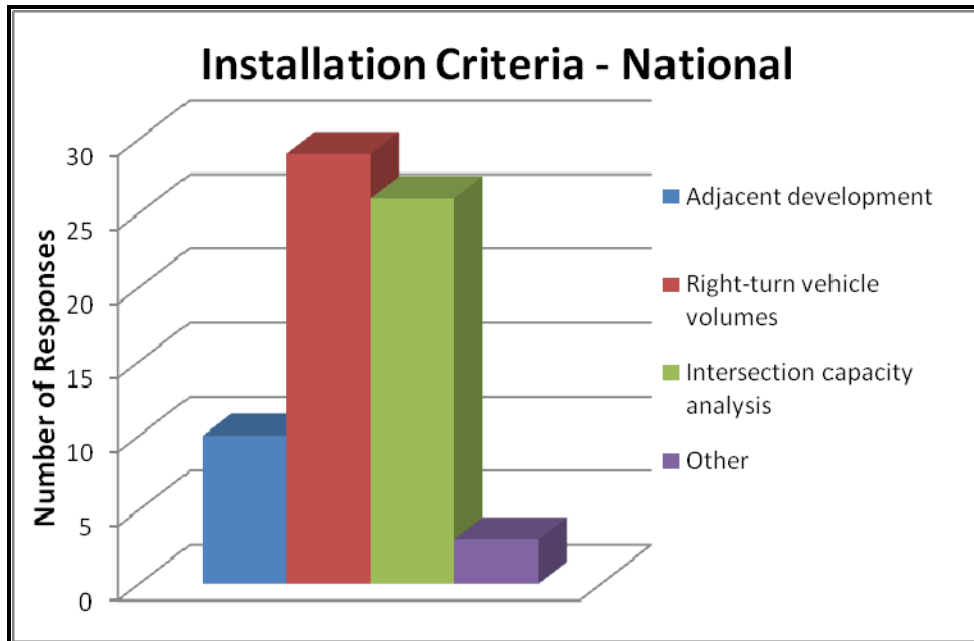
The survey respondents were asked to select all the design criteria that were applicable to the dual right-turn site design from the provided list. Figure 3-12 shows the frequency of selection for each design criteria.



**Figure 3-12. Design Criteria for Dual Right-Turn Installations (National Survey).**

- *Installation Criteria.*

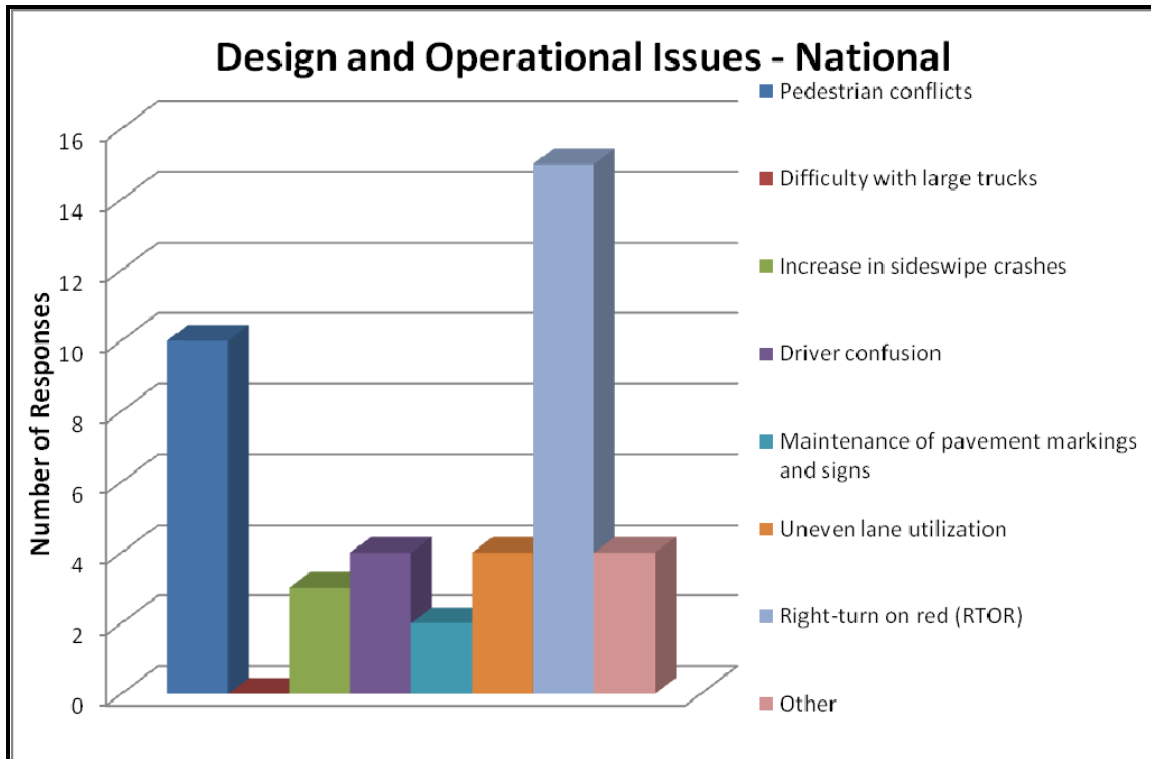
Figure 3-13 shows that *right-turn vehicle volumes* along with the *intersection capacity analysis* were the top two criteria for dual right-turn implementations according to the survey respondents.



**Figure 3-13. Installation Criteria for Dual Right-Turn Installations (National Survey).**

- *Design and Operational Issues.*

Figure 3-14 shows the design and operation issues faced by the survey respondents for the dual right-turn installations.



**Figure 3-14. Design and Operational Issues for Dual Right-Turn Installations (National Survey).**

- *Most Important Factors in Design and Operation of Dual Right-Turn Lanes.*

The survey respondents were asked to rate the list of seven factors based on their importance in the design and operation of dual right-turn lanes. The following is a list of factors in decreasing order of importance according to the survey results (1 = most important, 7 = least important).

1. Right-turn volume.
2. Traffic and geometric conditions upstream and downstream.
3. Storage length.
4. Selection of design vehicles.
5. Intersection angle.
6. Sight distance.
7. Intersection grade.

### 3.4 SYNTHESIS OF SURVEY FINDINGS

The researchers combined results from both the national survey and the state survey to analyze the existing guidelines around the country and in the state of Texas. The state survey helped the research team in identifying locations for data collections. The national survey gathered information about evaluation studies performed around the country to analyze a triple left-turn or a dual right-turn implementation.

Apart from the results shown in Section 3.2 and Section 3.3, the surveys provided other useful information to the research team. The overhead sign distance from the intersection with a triple left-turn installation or a dual right-turn installation for the majority of sites was between 250 ft to 500 ft. All the survey respondents mentioned that the protected-only signal phase is being used for triple left-turn sites and right-turn-on-red is allowed from both the lanes on most of the dual right-turn sites. The survey results also suggested that there is a need for guidelines for both the triple left-turn installations and the dual right-turn installations. Table 3-1 summarizes some of the most important installation and design criteria as well as some of the most important factors in design and operation of a triple left-turn or a dual right-turn.

**Table 3-1. Summary of Survey Results.**

<b>Category</b>	<b>Triple Left-Turn</b>	<b>Dual Right-Turn</b>
Design Criteria (Top 5)	<ul style="list-style-type: none"> <li>- Lane widths for receiving travel lanes</li> <li>- Intersection width for three design vehicles abreast</li> <li>- Design vehicle/turning template</li> <li>- Storage length</li> <li>- Signal head type and Installation</li> </ul>	<ul style="list-style-type: none"> <li>- Design vehicle/turning template</li> <li>- Intersection width for two design vehicles abreast</li> <li>- Pavement markings</li> <li>- Lane widths for receiving travel lanes</li> <li>- Storage length</li> </ul>
Installation Criteria	<ul style="list-style-type: none"> <li>- Left-turn vehicle volumes</li> <li>- Intersection capacity analysis</li> <li>- Adjacent development</li> </ul>	<ul style="list-style-type: none"> <li>- Right-turn vehicle volumes</li> <li>- Intersection capacity analysis</li> <li>- Adjacent development</li> </ul>
Most Important Factors in Design and Operation 1 = Most Important 7 = Least Important	<ol style="list-style-type: none"> <li>1. Intersection grade</li> <li>2. Sight distance</li> <li>3. Intersection angle</li> <li>4. Storage length</li> <li>5. Selection of design vehicles</li> <li>6. Traffic and geometric conditions upstream and downstream</li> <li>7. Left-turn volume</li> </ol>	<ol style="list-style-type: none"> <li>1. Intersection grade</li> <li>2. Sight distance</li> <li>3. Intersection angle</li> <li>4. Selection of design vehicles</li> <li>5. Storage length</li> <li>6. Traffic and geometric conditions upstream and downstream</li> <li>7. Right-turn volume</li> </ol>

## **CHAPTER 4 FIELD STUDIES**

### **4.1 FIELD STUDY PLAN**

The research team developed a field study plan to collect field data. The researchers developed the study plan by determining the intent of the field study and then providing necessary procedures through the use of collecting in-field static data and dynamic data. Lastly, the research team developed procedures for in-office data reduction of the information collected.

The research team at TTI collected field data at chosen sites in the Dallas/Fort Worth (DFW) area and the research team at TSU collected data at chosen sites in the Houston area. They developed a form letter explaining the purpose of the study and providing the project director's contact information, to be presented upon request at each study site where monitoring equipment were to be deployed.

#### **Intent of Field Studies**

The researchers sought to collect, at predetermined intersections, video data that would enable traffic operational information (i.e., volume counts, truck percentages, and saturation flow rates) to be analyzed in order to make multi-turn lane approaches at intersections operate more efficiently. Additionally, observational data were analyzed to determine any potential turn lane encroachment events, evasive maneuvers, or other critical events that can be used to enhance safety.

#### **In-Field Static Data**

For each location, the following information was documented:

- Name of location.
- Direction of approach.
- Approach and departure lane widths.
- Grade of approach street and departure street (estimated).
- Shoulder features (curbed, grassy, etc.).
- Pavement marking features (painted, raised pavement markers, etc.).
- Turn throat widths (if painted or estimated based on observation).
- Related traffic signs (digital still pictures can be taken).
- Upstream and downstream conditions (distance to next signal, congested or uncongested).
- Signal phasing times.
- Digital photos of each intersection (will assist documentation process).

## In-Field Dynamic Data

For each location video-recorded, the following procedures were followed:

- Positioned Camera 1 view to clearly see each lane of the approach from stop bar to at least 10 to 12 vehicles (approximately 200 ft) upstream of stop bar (not including trucks).
- Positioned Camera 2 view to focus on operations within the intersection where the turning maneuvers are occurring.
- Camera location schedule (provides two sets of data for each period):
  - Place first location on Monday before evening period.
  - Pickup first location on Wednesday after morning period.
  - Place second location on Wednesday before evening period.
  - Pickup second location on Friday after morning period.
  - Repeat for additional locations.
- Record video for the morning (6:00–9:00 a.m.) and evening (4:00–7:00 p.m.) peak periods.

## In-Office Data Reduction

For each location videotaped, the following tasks were performed:

- Examined Camera 2 and provided detailed notes on any types of various evasive maneuvers (i.e., near sideswipe), turning path irregularities (i.e., not staying in striped lane) that would affect safety.
- Examined Camera 1 and counted vehicle volume (cars and trucks separated) by lane for each lane of the approach for each period recorded (15-minute intervals).
- Examined Camera 1 and performed saturation-flow study by lane for each lane of the multi-turn lane approach for each period recorded (need a minimum of 30 observations for each lane of each location of each period; procedures attached).

## 4.2 SELECTION OF STUDY SITES

The research team prepared a list of dual right-turn and triple left-turn sites in Texas. The state survey also provided potential study locations. After reviewing the listed intersections for accuracy, field surveys of the sites were conducted and based on factors such as traffic volumes, intersection geometry, and proximity to the research offices; several intersections around Houston and Dallas were shortlisted for field data collections. Table 4-1 lists the selected triple left-turn sites, and Table 4-2 lists the selected dual right-turn sites.

**Table 4-1. Triple Left-Turn Sites for Field Data Collection.**

<b>Intersection</b>	<b>Location City</b>
Farm-to-Market (FM) 2499 at Gerault Road (Rd)	Flower Mound
State Highway (SH) 190 President George Bush Turnpike (PGBT) at Firewheel Drive (Dr)	Garland
Victory Avenue (Ave) at Continental Ave	Dallas
Westcott St at Memorial Dr	Houston



**Table 4-2. Dual Right-Turn Sites for Field Data Collection.**

<b>Intersection</b>	<b>Location City</b>
Precinct Line Rd at SH 183	Hurst
Lovers Lane (Ln) at US 75	Dallas
Six Flags Dr at Northbound (NB) SH 360	Arlington
North (N) Davis Dr at West (W) Lamar Boulevard (Blvd)	Arlington
Eastbound (EB) Forest Ln at IH-635 Frontage Road (FR)	Dallas
Roy Orr Blvd at N Carrier Parkway (Pkwy)	Grand Prairie
Westbound (WB) Plano Rd at IH-635	Dallas
Sherwin St at Washington Ave	Houston
West Bay Area Blvd at IH-45	Houston
Saturn Ln at NASA Pkwy	Houston
Shepherd Dr at IH-10	Houston
Kirby Dr at IH-610	Houston
US 59 at SH 6	Sugar Land

### **4.3 FIELD DATA COLLECTION**

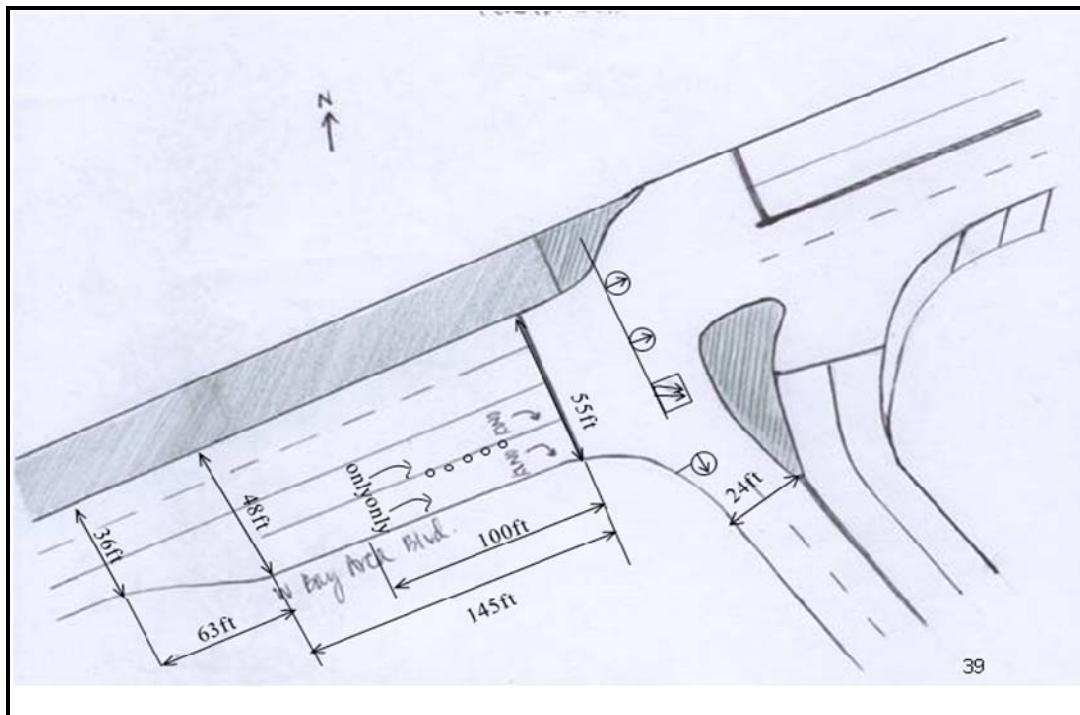
The researchers collected static in-field data and recorded information such as pavement markings/markers, receiving lane throat widths, and advanced traffic sign placement. The static data were collected using various measuring tools, stopwatches, and through in-field observation of the researchers/data collectors.

The mast-mounted video camera trailer at TTI and the Autoscope van at TSU were used to collect and record videos of traffic operations from each of the selected intersections. The recorded videos were sometimes used to verify signal timings at the intersections. The video data were used to identify critical events, such as lane encroachment and potential rear-end and side-swipe crashes. The video data were also used to collect peak hour traffic counts and lane saturation counts for all the selected intersections. Figure 4-1 shows an example setup of the Autoscope video van in the field.



**Figure 4-1. Example of Autoscope Van In-Field Setup.**

The research team documented the type of advanced traffic signs used at all the intersections. The lane widths at an intersection were recorded on an intersection layout as shown in Figure 4-2.



**Figure 4-2. Intersection Layout with Lane Widths – West Bay Area Blvd at IH-45.**

Figure 4-3 shows placement of an advanced traffic sign showing a triple left-turn ahead. The sign was placed on both sides of the southbound (SB) Gerault Road approach to FM 2499. SB Gerault Road has a sharp curve just before the FM 2499 intersection, so the position of this advanced sign was very important since motorists cannot see the actual intersection until they negotiate the horizontal curve.



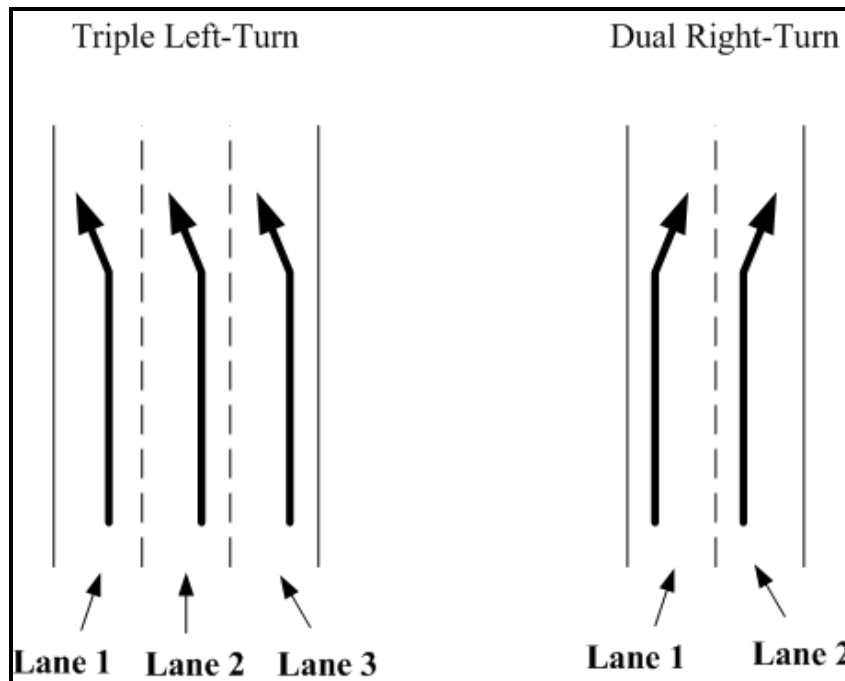
**Figure 4-3. Advanced Traffic Sign – Southbound Gerault Road Approach.**

Figure 4-4 shows painted pavement markings at the FM 2499 at Gerault Road intersection. The turning lane guidance markings help motorists stay in their lane while negotiating the left-turn.



**Figure 4-4. Pavement Markings at FM 2499 at Gerault Road Intersection.**

Figure 4-5 shows the lane numbering convention used for this research report. The same lane numbering convention is used throughout this report for consistency and ease of understanding. This lane numbering concept removes the confusion related to referring to both the lane closer to the curb and the lane closer to the median as inner lanes. Figure 4-5 shows the lane numbers for triple left-turns and dual right-turns. The focus of this research was on triple left-turns and dual right-turns, since triple right-turn lanes are very rare. However, there was one such intersection near one of the triple left-turn sites in Garland. Data were collected at that triple right-turn intersection, too, and is reported in this chapter.



**Figure 4-5. Lane Numbering Convention Used in Research Report.**

Table 4-3 provides a summary of the static data for all the dual right-turn locations covered in this research. Table 4-4 provides a summary of the static data for all the triple left-turn locations. The purpose of the static data collection was to spot any unusual characteristics that can provide inconsistent results when compared to other similar types of intersections. For example, SB North Davis Drive at West Lamar Boulevard in Arlington is not heavily used during traditional peak hours. Since it is near a school, however, the dual right turns have a higher amount of traffic around the school opening and closing times.

The video data reduction provided lane utilization for each of the studied locations and it also provided saturation counts by lanes. This section of this chapter summarizes the static data, and the next section of this chapter provides the operational data that were collected using the video data. The operational data pertain to the peak hour traffic period so that it is an even comparison across all the intersections.

**Table 4-3. Static Data Summary for Dual Right-Turn Intersections.**

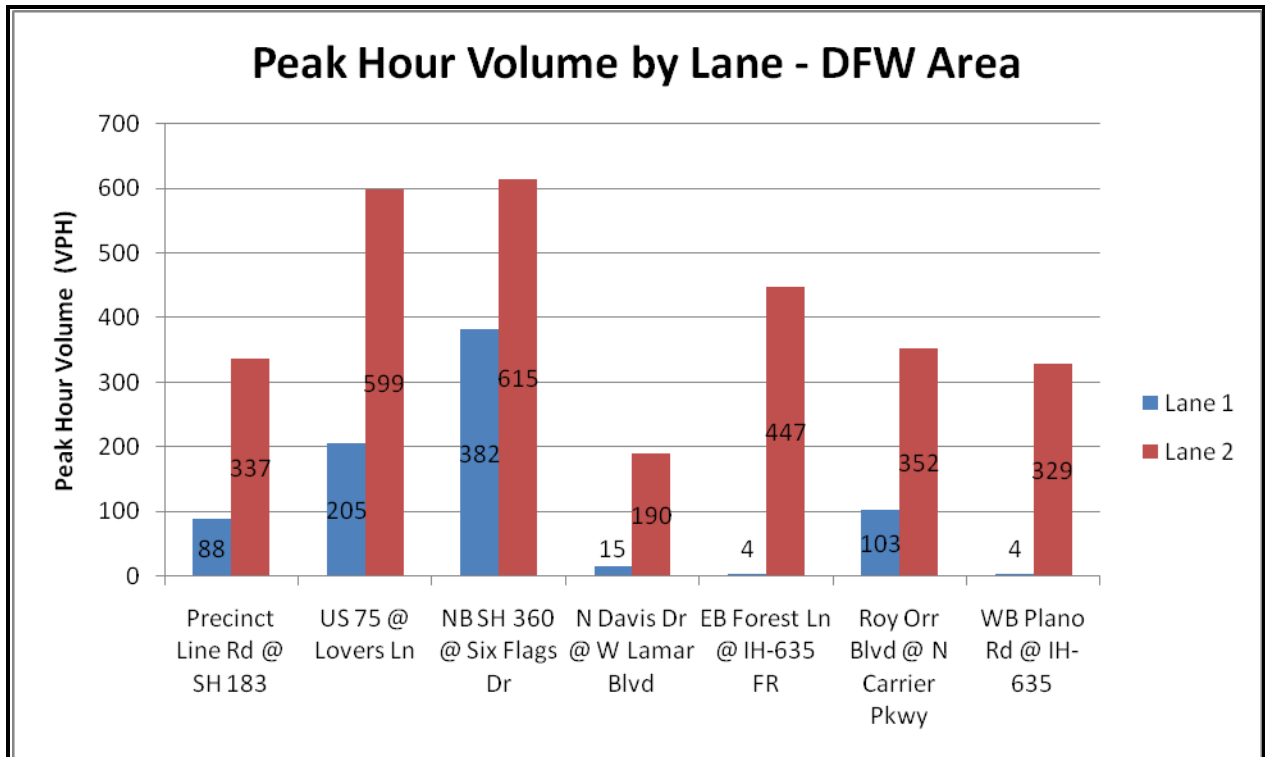
Intersection	Direction	Shoulder	Pavement Markings/Markers	Advance Traffic Signs (ft)
Precinct Line Rd at SH 183	SB	Raised curb	Painted	~ 400
Lovers Ln at US 75	NB	Raised curb	Painted	150
Six Flags Dr at SH 360	NB	Raised curb	Painted	225
N Davis Dr at W Lamar Blvd	SB	Raised curb	Painted	400
Forest Ln at IH-635 FR	EB	Raised curb	Painted	No
Roy Orr Blvd at N Carrier Pkwy	SB	Raised curb	Painted	300
Plano Rd at IH-635	WB	Raised curb	Painted	50
Sherwin St at Washington Ave	WB	Raised curb	Painted	200
West Bay Area Blvd at IH-45	NB	Raised curb	Painted	No
West Bay Area Blvd at IH-45	EB	Raised curb	Raised pavement marker (RPM)	No
Saturn Ln at NASA Pkwy	SB	Raised curb	Painted	75
Shepherd Dr at IH-10	WB	Raised curb	Painted	250
Kirby Dr at IH-610	WB	Raised curb	Painted	280
US 59at SH 6	NB	Raised curb	Lighted pavement marker (LPM)	45

**Table 4-4. Static Data Summary for Triple Left-Turn Intersections.**

Intersection	Direction	Shoulder	Pavement Markings/Markers	Advance Traffic Signs (ft)
FM 2499 at Gerault Rd	SB	Raised curb	Painted	400
SH 190 PGBT at Firewheel Dr	NB	Raised curb	Painted	550
Victory Ave at Continental Ave	SB	Raised curb	Painted	30
Westcott Dr at Memorial Ave	SB	Raised curb	Painted	No

#### 4.4 OPERATIONAL DATA ANALYSIS

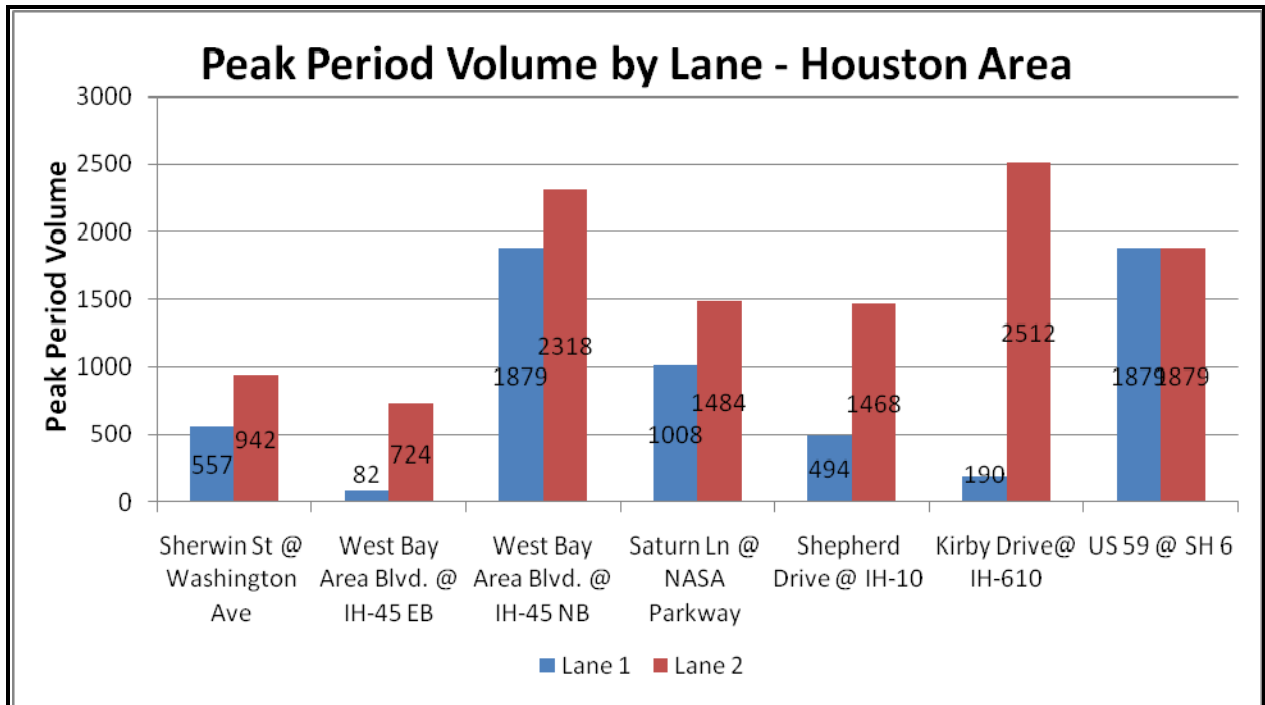
The research team analyzed the video data and obtained hourly traffic volumes and saturation counts for both the morning and evening peak periods. Figure 4-6 shows peak hour lane utilization data for all the dual right-turn sites in DFW.



**Figure 4-6. Lane Utilization for Dual Right-Turn Lane Sites (DFW Area).**

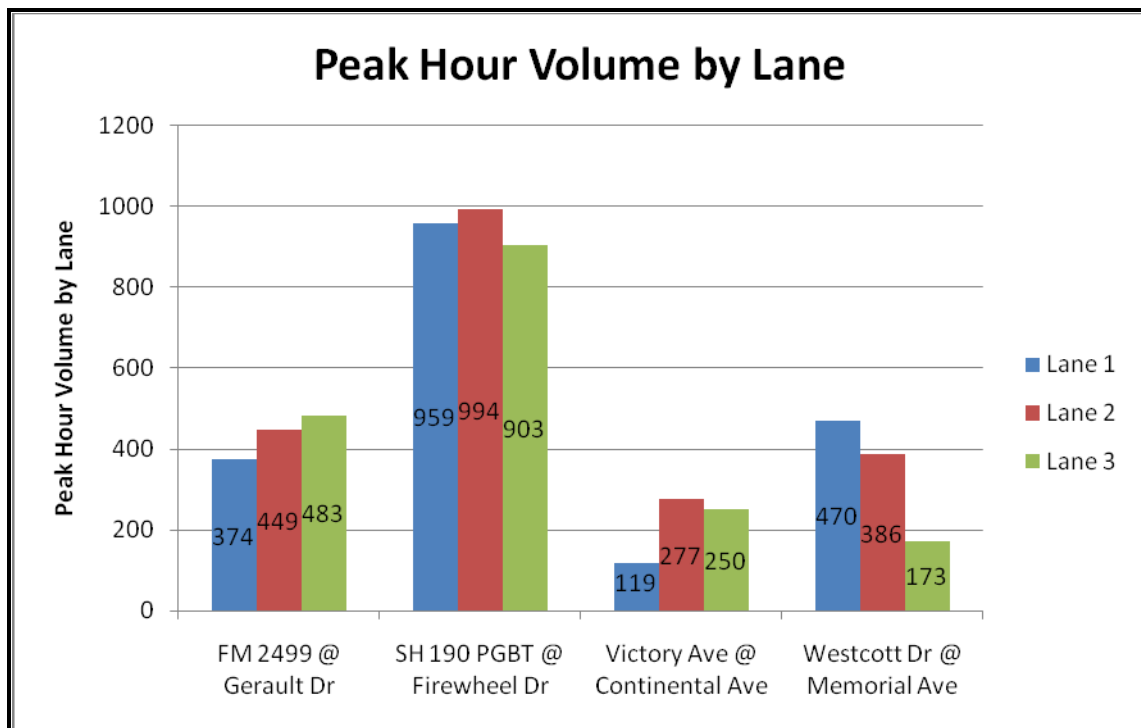
Since most of the dual right-turn sites in DFW area allowed RTOR, lane 2 in Figure 4-6 has substantially higher volumes when compared to lane 1. The research team expected this finding because it is logical that most drivers tend to choose the make the right turn from the lane closest to the curb on the outside (i.e., lane 2). The right turn volumes by lane showed that the volume in lane 2 depends on the downstream conditions. As an example, for the EB dual right-turn lanes at Forest Lane and IH-635 intersection, almost all the right turning traffic uses lane 2 although turning from lane 1 will provide better access to the freeway entrance ramp. One reason for this is the signal allows RTOR and turning from lane 2 allows a smoother turning radius and reduced conflicts with the oncoming traffic. The N Davis Dr at W Lamar Blvd site is near a public high school and most vehicles use lane 2 because the entrance to the student parking lot is immediately downstream. Only 15 vehicles during the peak hour use the lane 1 at this site, primarily as a way to bypass the majority of vehicles queued to enter the student parking area. The Six Flags Dr at NB SH 360 site has the highest overall utilization (almost 1,000 vehicles) and also the most even distribution between the two right-turn lanes. This dual right-turn is primarily feeding traffic onto either the WB or EB IH-30 entrance ramps.

Figure 4-6 shows a couple of locations that have higher lane 1 utilizations due to higher overall right-turn volumes at these locations. The lane utilization for dual right-turn sites in the Houston area shows similar trends. Figure 4-7 shows peak period lane utilization for dual right-turn sites in Houston.



**Figure 4-7. Lane Utilization for Dual Right-Turn Lane Sites (Houston Area).**

Figure 4-8 shows lane utilization for triple left-turn sites in the DFW and Houston areas combined since the Houston area had only one triple left-turn site.



**Figure 4-8. Lane Utilization for Triple Left-Turn Lane Sites.**



The Victory Avenue at Continental Avenue intersection, with approximately 640 left-turning vehicles per hour, has the lowest hourly volume among all four triple left-turn sites. The SH 190 PGBT at Firewheel Parkway intersection has the highest volume among these four sites, but it is a unique intersection since the north end of the PGBT begins at this intersection. In the WB direction, the left-turn from Firewheel Parkway is the only possible way to get on the PGBT at this point, so all the three left-turn lanes have an equal amount of traffic.

Table 4-5 shows average saturation flow for dual right-turn and triple left-turn sites. The saturation flow along with volume counts is very useful for planning stages of dual right-turn or triple left-turn installations.

**Table 4-5. Average Saturation Flow for Triple Left-Turn and Dual Right-Turn Sites.**

Type of Installation	Lane 1	Lane 2	Lane 3
Dual Right-Turn Lanes	1,717	1,668	
Triple Left-Turn Lanes	1,750	1,780	1,664

In the dual right-turn installations, lane 2 has the lower saturation flow rate while in the triple left-turn installations lane 3 has the lowest saturation flow. Since the saturation flows in Table 4.5 are averages of a limited number of sites, these numbers should not be used without taking into consideration the upstream/downstream conditions as well getting the average over a larger sample size. The average saturation flows are averages of three triple left-turn sites since one of the sites in the DFW area had low traffic volumes that made it impossible to obtain accurate saturation counts.

#### **4.5 INNOVATIVE TRIPLE LEFT-TURN IMPLEMENTATION**

One of the main concerns associated with triple left-turn installations is the delineation for the turn lanes across the intersection. The City of Sugar Land installed the in-pavement lighting to delineate a triple left-turn movement at the US 59 frontage road and SH 6 signalized diamond intersection in 2009. At the time of implementation, there were only a couple of locations in the United States that used lighted pavement markers (LPMs) to delineate turn lanes.

The LPM system is activated during the left-turn phase of the traffic signal cycle. The markers define the lane line between the two left-turn lanes and illuminate in a forward chase sequence, giving road users a sense of motion and providing positive directional guidance. The markers remain illuminated until the entire curve is lit; at this point, the chase sequence repeats.

The triple left-turn lanes became operational on November 20, 2009, at the Sugar Land site and the LPM system was activated at the same time. The LPM system is operated 24 hours a day in a steady-burn mode during every traffic signal cycle. For each cycle, the markers are activated at the beginning of the green traffic signal indication for the southbound US 59 movements, and the markers stay on until the end of the yellow signal indication. Figure 4-9 shows the activated LPMs along the triple left-turn lanes in daytime and Figure 4-10 shows the same installation in nighttime conditions.





**Figure 4-9. Triple Left-Turn LPM System in Sugar Land, Texas (Daytime).**



**Figure 4-10. Triple Left-Turn LPM System in Sugar Land, Texas (Nighttime).**

TTI staff in Houston performed an operational evaluation of the LPM system after the LPM system was activated. The SB US 59 approach to SH 6 was video recorded when the LPM system was active and when it was inactive. These recordings were reviewed to determine traffic volumes for each movement of each lane for the SB US 59 approach to the intersection. In

addition, several types of vehicle maneuvers including lane changes and instances of vehicles driving on or over the lane lines were also documented.

The video recordings are mostly comprised of typical weekday traffic during non-inclement weather conditions. However, due to extended periods of extremely poor weather during the LPM OFF data collection period, one of the two 24-hour periods was comprised of periods of Friday evening and Saturday morning traffic. Although this situation is not ideal, a comparison of the traffic volumes when the LPMs are ON and when the LPMs are OFF shows that there is not a significant change in the traffic volumes.

The results of the operational study showed that the lane keeping violations were significantly higher during the LPM OFF period as compared to the LPM ON period. This indicates that the LPMs may help drivers navigate the left turns better and stay in the designated lanes. The study also showed that the LPMs may help reduce the number of illegal through movements from a left-turn-only lane.

#### **4.6 SUMMARY OF FIELD STUDIES**

Field studies of the dual right-turn and triple left-turn installations provided significant information about each of these sites. Field information, such as upstream/downstream conditions of each intersection, provided some very important information related to lane usage at a particular intersection. The lane usage data from the field videos provided approximate threshold values for the dual right-turn and triple left-turn installations. Static field data, such as throat width measurements combined with literature review, provided a base for some of the guidelines developed in the later chapters of this research report. The advance traffic information sign distances along with the national and state survey results provided valuable distance information related to advance traffic signs.

## CHAPTER 5 SAFETY PERFORMANCE EVALUATION

### 5.1 STUDY SITES AND METHODOLOGY

#### Selected Study Sites

TTI recommended a list of candidate study sites that were further selected from the candidate turn lanes. For the collision diagrams-based study and comparison study, a total of 20 dual right-turn lane and five triple left-turn lane sites were selected based on the availability of crash history (Table 5-1).

**Table 5-1. Study Sites for Collision Diagrams-Based Study and Comparison Study.**

City	Intersection
<b>Triple Left-Turn Lanes (5 intersections)</b>	
Dallas	East (E) Northwest Highway at N Buckner Blvd
	Victory Ave at Continental Ave
	N Griffin St at N Field St
Houston	Westcott Street at Memorial Drive
Flower Mound	FM 2499 at Gerault Rd
<b>Dual Right-Turn Lanes (20 intersections)</b>	
Arlington	SH 360 at Six Flags Dr
Austin	Spicewood Springs Rd at Loop 360
Dallas	Lovers Ln at US 75 NB
	Forest Ln at IH-635
	Preston Rd at IH-635
	Galleria Rd at NB Dallas North Tollway (DNT)
	IH-35E at Continental Ave
Frisco	Gaylord Pkwy at NB DNT
	Warren Pkwy at NB DNT
	Main St at SB DNT
Grand Prairie	N Carrier Pkwy at Roy Orr Blvd
Houston	Sherwin St at Washington Ave
	Saturn Ln at NASA Pkwy
	Shepherd Dr at IH-10
	IH-610 at Kirby Dr
Lewisville	W Main St/FM 1171 at EB IH-35E
Plano	Legacy Dr at NB DNT
San Antonio	Babcock Rd at WB IH-410
	AT&T Center Pkwy at IH-35
Sugar Land	US 59 at SH 6

For the field traffic conflict study, a total of six dual right-turn lanes and one triple left-turn lane sites were selected considering the cost and feasibility of conducting field study (Table 5-2).

**Table 5-2. Study Sites for Field Traffic Conflict Study.**

City	Intersection
Triple Left-Turn Lanes (1 intersection)	
Houston	Westcott St at Memorial Dr
Dual Right-Turn Lanes (6 intersections)	
Houston	Sherwin St at Washington Ave
	Saturn Ln at NASA Pkwy
	Shepherd Dr at IH-10
	IH-610 at Kirby Dr
	West Bay Area Blvd at IH-45 (NB and EB)
Sugar Land	US 59 at SH 6

**Data Collection/Processing Procedure**

Different data collection/processing procedures were used for various analysis approaches.

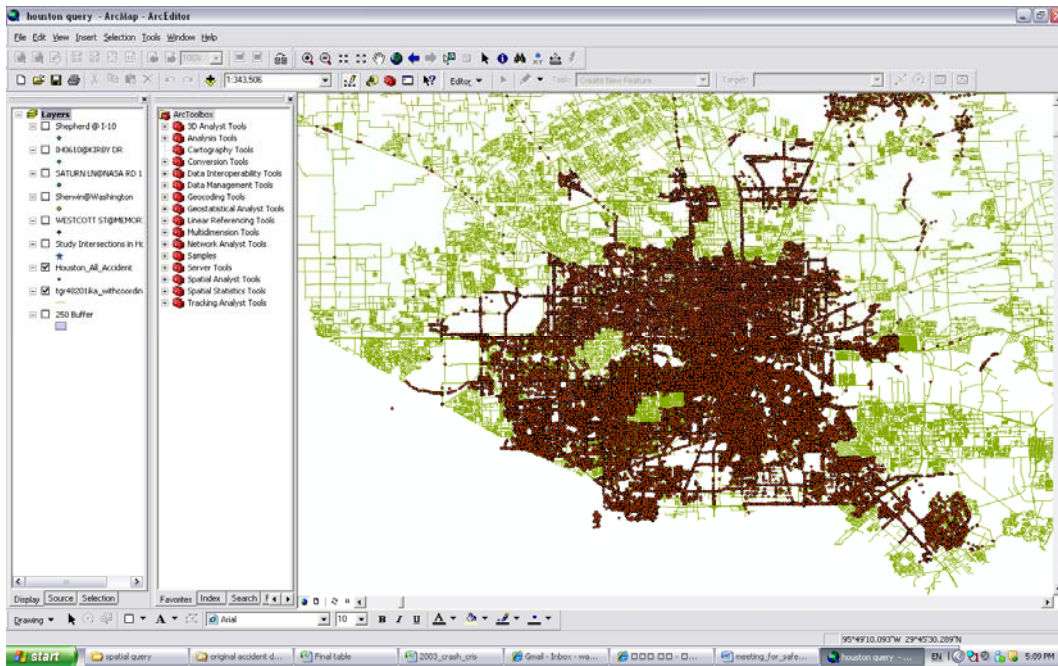
***Collision Diagrams-Based Study and Comparison Study***

Historical crash records during the year 2003 to 2008 were collected from the Crash Records Information System (CRIS) database. To create collision diagrams and conduct the comparison studies, all crashes related to the study intersections were identified and detailed police reports were collected according to the identified crash IDs. The data processing procedure can be described as follows:

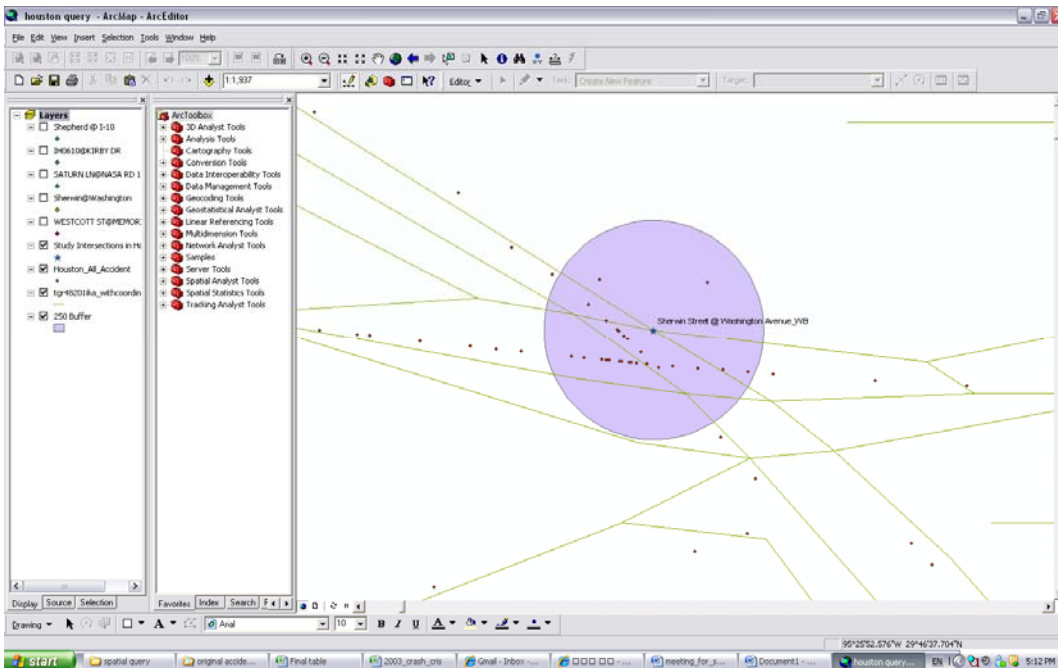
***Step 1: Identify Crashes Related to the Study Intersections***

Each data sample contains a longitude and latitude of the crash location, which enables a spatial distribution analysis. Using ArcMap GIS software, the locations of crashes can be displayed on maps as illustrated in Figure 5-1.

A spatial layer for the study intersections was created in the GIS map. To identify the crashes related to the study intersections, buffer areas of the study intersections were created to indicate safety influence areas of the study intersections. The criterion used in this project is that all the crashes within a circle of a 250-ft radius are considered related to the selected intersection, as shown in Figure 5-2. The 250 ft distance was determined based on the research results in Abdel-Aty et al. (2009). The major reason for setting this relatively large safety influence area is that the dual right-turn/triple left-turn lanes are typically installed at large intersections with relatively heavy volumes and high approach speed limits.



**Figure 5-1. Crash Map in Houston.**



**Figure 5-2. Identification Process of Crashes Related to Study Intersections.**

Then, the collision type codes available in the “Crash\_CRIS” file were used to further identify the crashes that may be related to dual right or triple left-turn lanes.

*Step 2: Collect Detailed Police Reports for Identified Crashes*

As outputs of Step 1, the IDs of the crashes related to the study intersections were used to designate the police reports needed for the analysis. A total of 4,630 related police reports during calendar year 2003 through 2008 were gathered at the 25 study sites listed in Table 5-1. By closely examining these reports, the researchers excluded some crashes that are totally unrelated to the dual right or triple left-turn lanes from the analysis.

### ***Field Traffic Conflict Collection***

Peak-period traffic conditions were simultaneously and continuously recorded at the selected intersections in the Houston area. The focus was on the turning and receiving segments of the intersections. The observation periods spanned from 6:00 a.m. to 9:00 a.m. and from 4:00 p.m. to 7:00 p.m. The recorded videos were replayed in the office for analysis. Various traffic conflicts associated with triple left and dual right-turn lanes were observed and counted. Uniform procedures/criteria were used to identify critical traffic conflicts.

## **5.2 COLLISION DIAGRAM SAFETY PERFORMANCE ANALYSIS**

Collision diagrams are graphic representations of intersections under analysis, and they provide detailed information about the crash locations and the hot spots of certain types of crashes, which are useful for diagnosing the safety problems at specific sites. In this study, collision diagrams were created for each study intersection. To this end, detailed police reports for each crash related to the study intersections were analyzed. The police reports include the crash locations, crash types, and crash directions. According to the collision diagrams, the crash patterns were analyzed, and the contributing factors were identified.

### **Data Analysis Procedure**

After the detailed crash reports were fully prepared, the reports were analyzed using the following procedures:

#### ***Step 1: Create Collision Diagrams***

Each crash was mapped on the intersection diagram. Various symbols were used to illustrate the collision type, and the total counts were labeled beside each collision type. Table 5-3 summarizes the crash counts by crash types.

#### ***Step 2: Analyze Crash Patterns and Causes***

The crash patterns and causes were analyzed by examining the crash counts, locations, crash types, and related geometric and environmental conditions. The analysis results will be presented in the following section.

**Table 5-3. Dual Right and Triple Left-Turn Related Crashes (Six-Year Counts: 2003–2008).**

Type	Intersection	Rear-End	Angle	Right-Turn/Left-Turn	Sideswipe	Back	Bike	Object	Others
Dual right-turn lanes	AT&T Center Pkwy at IH-35	12	0	0	1	0	0	0	0
	Galleria Rd at NB DNT	0	0	0	1	0	0	0	0
	Gaylord Pkwy at NB DNT	0	0	0	0	0	0	0	0
	IH-35E at Continental Ave	0	0	0	0	0	0	0	0
	Babcock Rd at WB IH-410	12	4	0	0	0	1	0	0
	Preston Rd at IH-635	0	3	0	0	0	0	0	0
	Forest Ln at IH-635	0	0	0	0	0	0	0	0
	IH-610 at Kirby Dr	11	1	0	0	0	0	0	0
	Legacy Dr at NB DNT	0	4	2	1	0	0	1	0
	Main St at SB DNT	0	3	0	0	1	0	0	0
	Main St/FM 1171 at IH-35E	0	15	1	2	0	0	0	0
	N Carrier Pkwy at Roy Orr Blvd	0	2	0	0	0	0	0	1
	Saturn Ln at NASA Pkwy	0	0	0	0	0	0	0	0
	Six Flags Dr at SH 360	46	8	1	1	3	0	0	0
	Shepherd Dr at IH-10	0	3	0	0	0	0	0	0
	Sherwin St at Washington Ave	0	3	0	0	0	0	0	0
	Spicewood Springs Rd at Loop 360	0	0	0	0	0	0	0	0
	US 59 at SH 6	4	12	0	1	0	0	0	0
	Lovers Ln at NB US 75	0	0	0	2	0	0	0	0
Warren Pkwy at NB DNT	0	0	1	0	0	0	1	0	
Triple left-turn lanes	Northwest Highway at Bucker Blvd	0	0	1	1	0	0	0	0
	Victory Ave at Continental Ave	0	0	1	3	0	0	0	0
	Griffin St at Field St	0	2	1	0	0	0	2	0
	Westcott St at Memorial Dr	1	2	1	0	0	0	0	0
	FM 2499 at Gerault Rd	2	2	1	0	0	0	3	0

## Collision Diagrams Analysis Results

Based on the developed collision diagrams (see Appendices A and B) and the crash statistics by crash types (see Table 5-3), the crash patterns at each study intersection were analyzed and the crash contributing factors at each site were identified.

### *Triple Left-Turn Lanes*

The numbers of crashes are generally very low (equal or less than three for any type of crashes during a six-year period), which reveals that triple left-turn lanes commonly do not have significant safety problems.

### *Dual Right-Turn Lanes*

To facilitate investigating the crash patterns and contributing factors for each type of crash, the geometric conditions for the study intersections are presented in Table 5-4.

**Table 5-4. Intersection Geometric Conditions (Dual Right-Turn Lanes).**

City	Intersection	Channelized	Skewed or Not	Turning Radius		Left-Side (L) Exclusive (E) or Shared (S) Lane
				Range*	Ft	
Arlington	Six Flags Dr at SH 360	Yes	>90	Large	125	S
Austin	Spicewood Springs Rd at Loop 360	No	>90	Large	67	S
Dallas	Forest Ln at IH-635	No	>90	Medium	46	S
	Preston Rd at IH-635	No	>90	Small	21	S
	Galleria Rd at NB DNT	No	=90	Small	22	S
	Lovers Ln at NB US 75	No	>90	Medium	33	S
	IH-35E at Continental Ave	No	>90	Medium	26	S
Frisco	Gaylord Pkwy at NB DNT	No	<90	Medium	48	E
	Warren Pkwy at NB DNT	No	<90	Medium	46	E
	Main St at SB DNT	No	>90	Medium	48	S
Grand Prairie	N Carrier Pkwy at Roy Orr Blvd	No	=90	Medium	37	E
Houston	Shepherd Dr at IH-10	No	=90	Small	22	S
	Sherwin St at Washington Ave	No	>90	Large	114	S
	IH-610 at Kirby Dr	Yes	=90	Large	73	S
	Saturn Ln at NASA Pkwy	Yes	=90	Medium	33	E
Lewisville	Main St at IH-35E	No	>90	Large	59	S
Plano	Legacy Dr at NB DNT	No	=90	Small	22	S
San Antonio	Babcock Rd at WB IH-410	No	>90	Large	82	S
	AT&T Center Pkwy at IH-35E	Yes	=90	Large	117	S
Sugar Land	US 59 at SH 6	No	>90	Medium	50	E

\*: Small radius (20–25 ft); Medium radius (25–50 ft); Large radius (>50 ft)



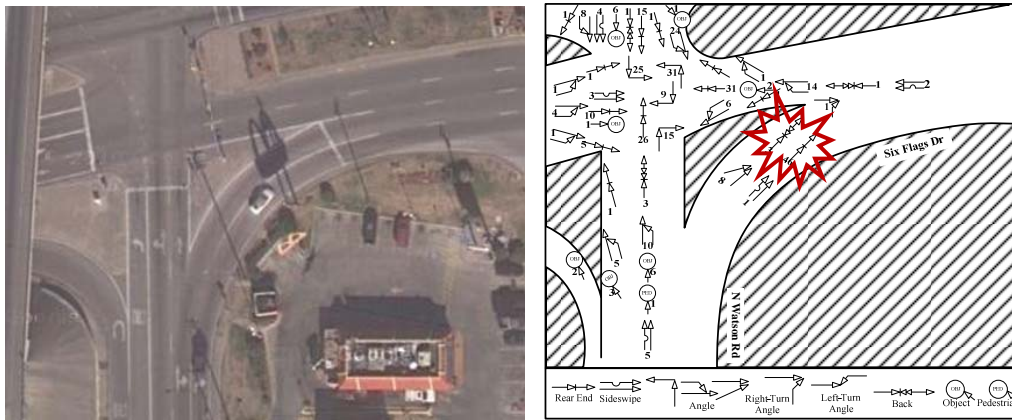
***Rear-End Crashes***

Table 5-3 shows that rear-end crashes are the major types of crashes that occurred at dual right-turn lanes. Four intersections including AT&T Center Parkway at IH-35, Six Flags Drive at SH 360, Kirby Drive at IH-610, and Babcock Road at WB IH-410, had high rates of rear-end crashes. By closely examining the crash reports, the research team found that there are two major causes for high rear-end crash rates: presence of channelization and short deceleration distance from an exit ramp.

***Cause 1: Presence of Channelization***

Of the four intersections with high rear-end crash rates, three intersections are channelized (Six Flags Drive at SH 360, Kirby Drive at IH-610, and AT&T Center Parkway at IH-35). By contrast, 15 of the 16 intersections without high rear-end crash records in Table 5-3 are unchannelized (see Table 5-4 for the related geometric conditions).

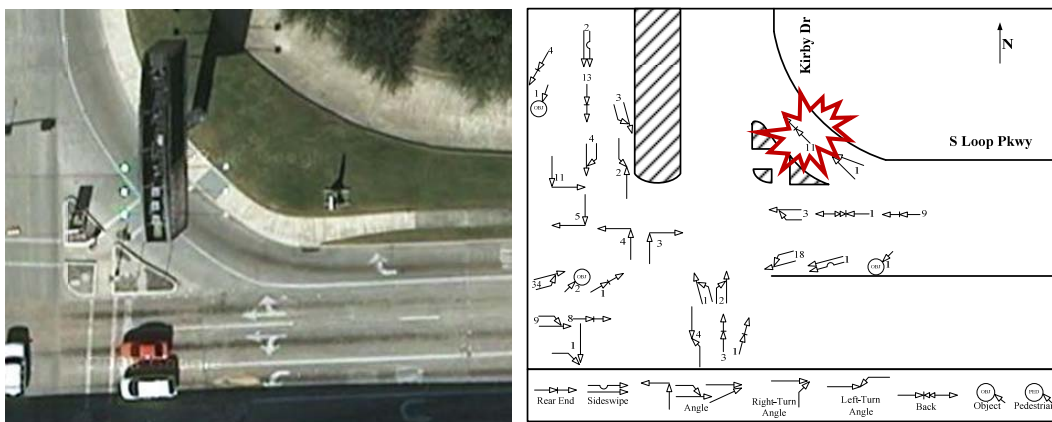
According to the crash reports, at channelized intersections, right-turn vehicles tend to keep relatively high speeds. If one leading vehicle stops at a yield sign or at a red light signal to yield to cross-street traffic, the follow-up vehicles may fail to stop and hit the leading vehicles when their focuses are partially on the cross-street traffic. Figures 5-3 through 5-5 show the intersections subject to high rear-end crash rates, and highlights the accident hot spots where most of the rear-end crashes occurred (e.g., near yield signs, stop signs, or traffic signal stop bars).



**Figure 5-3. Rear-End Crash Hot Spots at Six Flags Drive at SH 360.**



**Figure 5-4: Rear-End Crash Hot Spots at AT&T Center Parkway at IH-35.**



**Figure 5-5: Rear-End Crash Hot Spots at Kirby Drive at IH-610.**

***Cause 2: Short Deceleration Distance from an Exit Ramp***

Another major cause for high rear-end crash rates is the short deceleration distance from an exit ramp to the right-turn lane (For example, the intersection at Babcock Road at IH-410 WB shown in Figure 5-6). A short deceleration distance from an exit ramp will result in a relatively high speed approaching the intersection, which explains the high rear-end collision risk.



**Figure 5-6. Illustration of Short Deceleration Distance as a Contributor to Rear-End Crashes (Babcock Road at WB IH-410, San Antonio).**

### ***Angle Crashes***

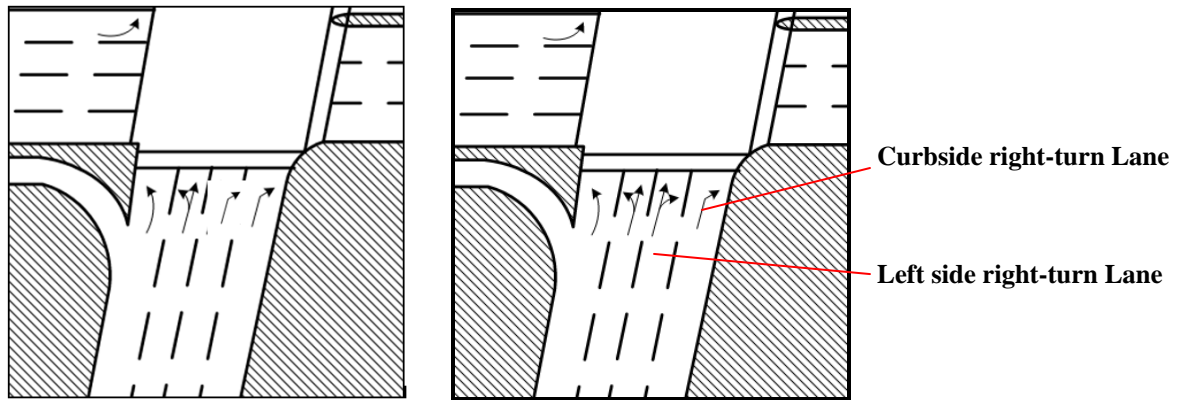
Another leading crash type related to dual right-turn lanes is the angle crash, which occurs when one vehicle changes lane unsafely and collides with another vehicle traveling on the neighboring lane. Table 5-3 shows seven dual right-turn lanes sites that presented high angle crash rates. These seven intersections are Preston Road at IH-635, Legacy Drive at NB DNT, Main Street at SB DNT, Main Street at IH-35E, Shepherd Drive at IH-10, US 59 at SH 6, and Sherwin Street at Washington Avenue. The related crash reports revealed that the high angle crash rates resulted from the following four major causes:

- “Trapped” through drivers in the curbside right-turn lane, which is dedicated to right turns in the dual turn lane group.
- A high percentage of heavy vehicles.
- Unclear or confusing turning guide lines.
- Small turning radii.

### ***Cause 1: “Trapped” Through Drivers in the Curbside Right-Turn Lane***

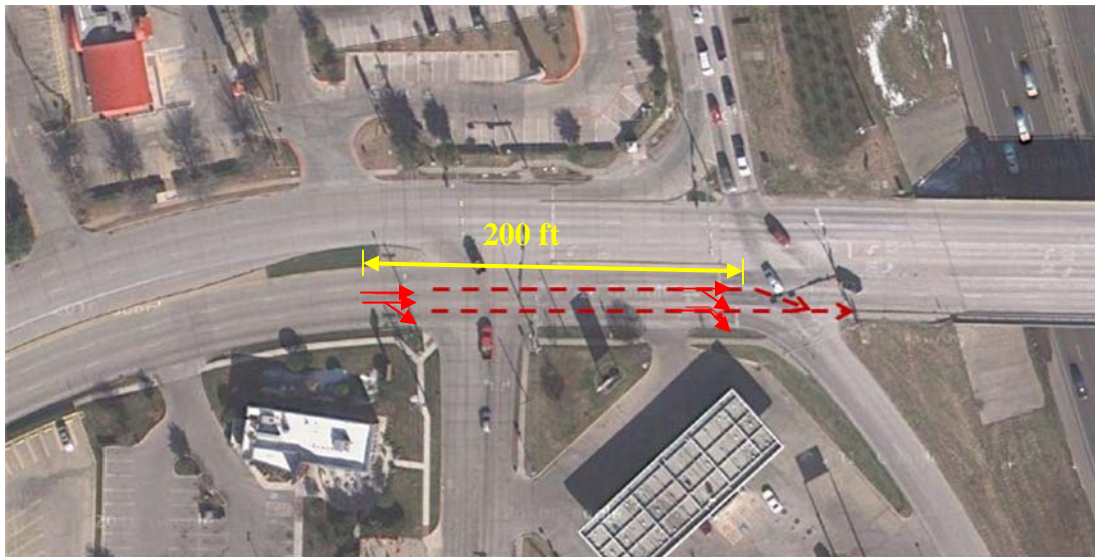
There are two possible types of lane configurations for the dual right-turn lanes (see Figure 5-7). In both cases, the curbside turning lane is dedicated for right-turns, while the left side turning lane could be either shared or exclusive for right-turns. Some unfavorable geometric conditions may trap the through vehicles on the curbside right-turn lane that is dedicated to right turns only. In these cases, severe traffic conflicts will occur if the through drivers still try to go straight through the curbside right-turn lane while the vehicles in the left side right-turn lane are turning right. The representative examples for this problem are the dual right-turn lanes on Main Street at IH-35E and Sherwin Street at Washington Avenue. The reasons why through drivers were trapped in the curbside right-turn lane vary and should be handled on a case-by-case basis.





**Figure 5-7. Lane Configurations for the Dual Right-Turn Lanes.**

On Main Street at IH-35E (see Figure 5-8), there is an intersection closely spaced approximately 200 ft upstream. The curb lane (a shared right-turn lane) at the upstream intersection is aligned with the curb lane of dual right-turn lanes at the downstream intersection. The through vehicles are discharged from the shared right-turn lane at the upstream intersection; they will enter the curbside lane in a dual right-turn lane group. Because there is insufficient distance for the through vehicles to change lanes safely, they are trapped in the curbside right-turn lane. In this case, the through vehicles may risk attempting to go straight because if they forced to turn right, they would deviate from their desired path.



**Figure 5-8. Main Street at IH-35E.**

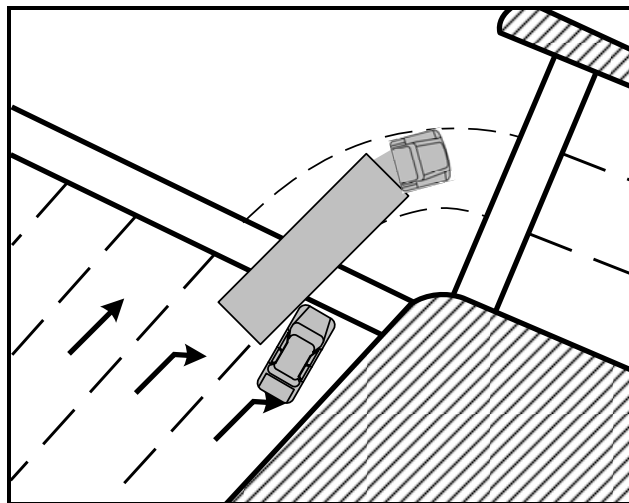
On Sherwin Street at Washington Avenue (see Figure 5-9), through vehicles from the frontage road may be unable to safely change to the through lane (in the middle of the approach) due to the short distance available for the lane change. As a result, they may be trapped in the curbside right-turn lane of the dual right-turn lane at this location.



**Figure 5-9. Sherwin Street at Washington Avenue.**

***Cause 2: High Percentage of Heavy Vehicles***

The police accident records indicate that most angle crashes on US 59 at SH 6 were caused by the presence of heavy vehicles. In this location, it is difficult for the heavy vehicle drivers to keep the container chassis in the lane, which may result in collisions with the vehicles turning from the other right-turn lane (see Figure 5-10).

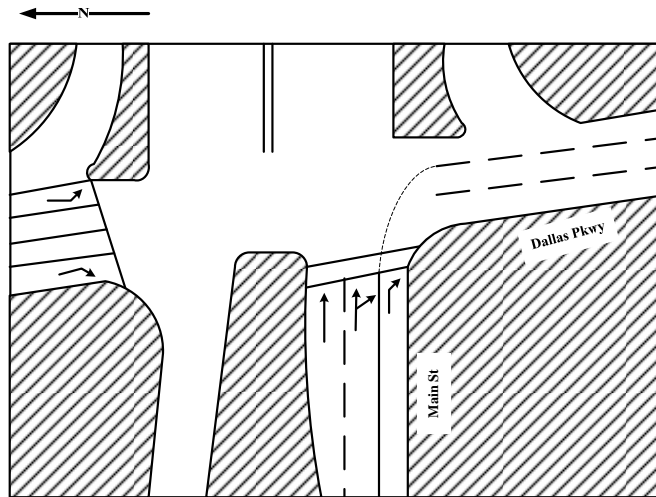


**Figure 5-10. Illustration of Heavy Vehicle as a Cause of Angle Crashes.**

***Cause 3: Unclear or Confusing Turning Guide Lines***

Turning guide lines are a key design element associated with dual right-turn lanes, since these provide important guidance for drivers to avoid the conflicts between two right-turn vehicles turning abreast. By examining the crash reports and the pavement markings currently in use, unclear or confusing turning guide lines are considered a contributor to angle crashes at dual right-turn lanes.

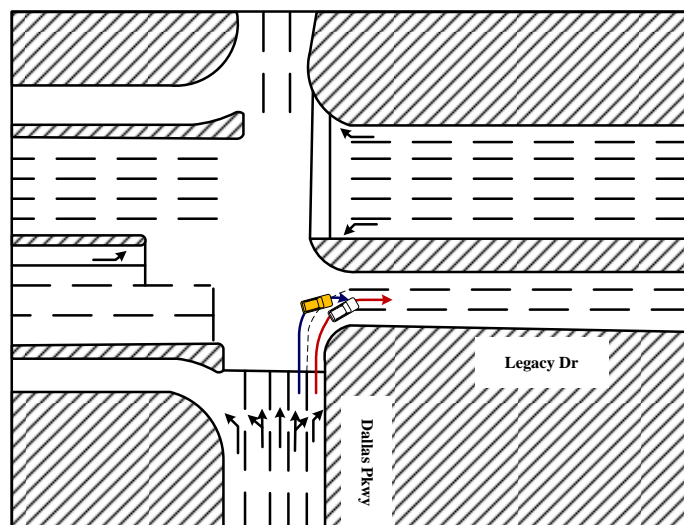
For example, on Main Street at SB DNT (see Figure 5-11), the crash report specifies that “there is a traffic control device that directs vehicles turning from the outside right-turn lane to turn into the far left lane of Dallas Parkway; however, the markings are faded and could not be seen.”



**Figure 5-11. Illustration of Unclear or Confusing Turning Guide Lines as a Contributor to Angle Crashes (Main Street at SB DNT).**

*Note: Dallas Parkway is another name commonly used to refer to the frontage roads of the DNT.*

On Legacy Drive at NB DNT, the turning guide line is confusing (see Figure 5-12). There are two receiving lanes available for the curb right-turn lane. But the right-turn drivers on the left side right-turn lane may understand they can also utilize the middle receiving lane, following a “convention.” On Preston Road at IH-635, there is no turning guide lines provided, which contributed to the angle crashes at this location.



**Figure 5-12. Illustration of Unclear or Confusing Turning Guide Lines as a Contributor to Angle Crashes (Legacy Drive at NB DNT).**

#### *Cause 4: Small Turning Radii*

The dual right-turn lanes at Shepherd Drive at IH-10 have a turning radius of 22 ft, which is relatively too small for vehicles to keep in the lane while turning.

### **Conclusions and Recommendations**

The major findings in the collision diagram based safety analysis can be summarized as:

- Triple left-turn lanes commonly do not present significantly high crash rates.
- Presence of channelization is a major contributing factor to high rear-end crash rates at dual right-turn lanes.
- Angle crashes at dual right-turn lanes can be caused by:
  - “Trapped” through drivers on the curbside exclusive right-turn lane under unfriendly geometric conditions.
  - Inappropriately designed elements (e.g., small radii, confusing turning guide lines).

Accordingly, the following recommendations can be provided:

- For closely spaced intersections, if a downstream intersection uses dual right-turn lanes, the curbside right-turn lane should not be aligned with the through lane at the upstream intersection.
- Clear turning guide lines are critically needed. Additionally, it is not recommended to provide turning guide lines that allow the curbside right-turn lane to have two optional receiving lanes (e.g., Figure 5-11).
- Turning radii should be not less than 25 ft at dual right-turn lanes.

### **5.3 FIELD TRAFFIC CONFLICT STUDY**

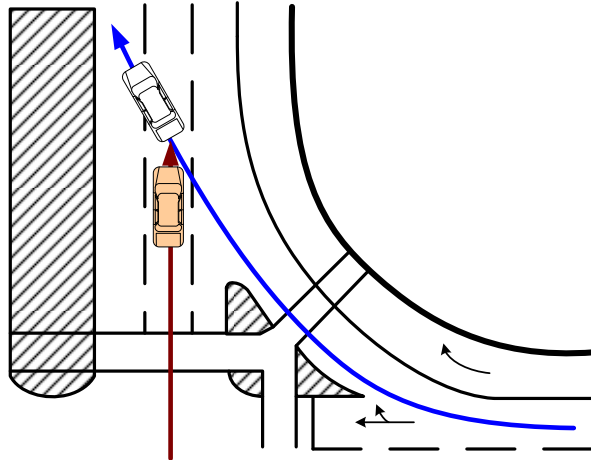
A traffic conflict study is a good supplemental method for a collision-based safety study. Traffic conflict is defined as the interaction of two or more drivers where one or more drivers take evasive action to avoid a collision. It usually takes short periods of field traffic observation and provides the most effective ways to supplement historical data studies to reveal the crash potential of dual right/triple left-turn lanes.

#### **Traffic Conflicts Observed**

Four types of traffic conflicts were collected during the field conflict study and are defined below.

- Lane encroachment conflict: An encroachment is defined as a type of event in which a turning vehicle fails to keep in its lane as the turning guide lines confine.
- Rear-end conflict: A rear-end conflict is defined as an event when one leading vehicle suddenly or unexpectedly stops or slows down, and the follow-up vehicle in the same turning lane has to make a hard braking maneuver to avoid a collision.
- Cross-movement conflict: A cross-movement conflict is an event when a turning vehicle fails to go to the designated receiving lane while infringing on the right-of-way of cross-street traffic (see Figure 5-13). As a result of a cross-movement conflict, the cross-street

vehicles may have to make a hard brake or an evasive maneuver to avoid a rear-end collision with the turning vehicles.



**Figure 5-13. Illustration of Cross-Movement Conflicts.**

- Lane blockage conflict: A lane-blockage conflict is an event when through lanes block turn lanes or turning vehicles block through lanes. Table 5-5 shows the counts for each type of traffic conflicts.

**Table 5-5. Traffic Conflict Counts in the Field Studies.**

Type	Name	Lane Encroachment	Rear-End	Cross-Movements	Lane Blockage	Total Conflicts Counts
Triple left-turn lanes	Westcott St at Memorial Dr	34	0	0	0	34
Dual right-turn lanes	US 59 at SH 6 (NB)	13	0	0	0	13
	Saturn Ln at NASA Parkway (SB)	1	N/A*	5	0	6
	West Bay Area Blvd at IH-45(NB)	3	1	0	0	4
	West Bay Area Blvd at IH-45(EB)	49	0	0	0	49
	Sherwin St at Washington Ave (WB)	71	0	0	0	71
	Shepherd Dr at IH-10 (WB)	2	0	0	2	4
	Kirby Drive at IH-610 (WB)	49	9	0	0	58

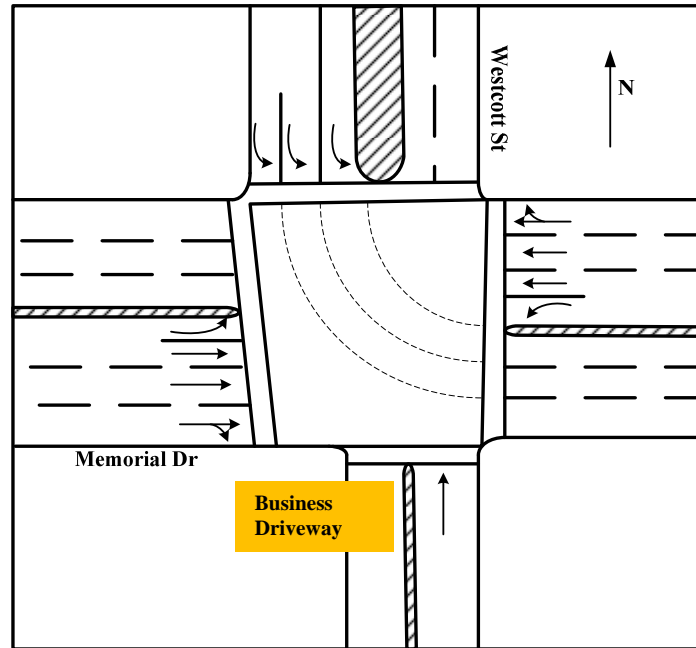
\*: The rear-end conflict was not collected at this location as the view of the turning roadway was partially blocked by the roadside trees.

**Traffic Conflict Analysis Results**

For the triple left-turn lanes, the only type of traffic conflicts observed in the field were lane encroachments. From Table 5-5, there were 34 cases of lane encroachments along Westcott Street at the Memorial Drive intersection. The southbound leg of Westcott Street ends at



Memorial Drive, where there is a business driveway, requiring vehicles on Westcott Street to either make a left or right-turn (see Figure 5-14). Although the turning movements are well signed near the business driveway for southbound vehicles, drivers who do not realize the presence of triple left-turn lanes may mistakenly want to go straight into the business driveway and thus cause a lane encroachment conflict. Some of the other lane encroachment conflicts at the site are caused by heavy vehicles, which failed to stay in their lane while turning.



**Figure 5-14. Triple Left-Turn Lanes on Westcott Street at Memorial Drive.**

For dual right-turn lanes, the traffic conflict counts were compared between the study sites, so as to identify the contributing factors to the safety issues related to the problematic dual right-turn lanes. To this end, related information, including the intersection geometric conditions, traffic volumes, percentage of heavy vehicles, speed limit, traffic signal control, and traffic signs in use were also collected in the field. Table 5-6 shows the observed field study characteristics.

**Table 5-6. Characteristics of the Field Traffic Conflict Study Locations.**

Name	Exclusive or shared right-turn lanes	Pavement markings/markers	Channelization	Turning angle	Turning radius	RTOR allowed	Exclusive signal head	Turning volume (vph)	% of heavy trucks	Speed limit (mph)
US 59 at SH 6 (NB)	Exclusive + Exclusive	Raised pavement markers	No	>90°	Large	Yes	Yes	752	3.7	50
Saturn Ln at NASA Pkwy (SB)	Exclusive + Exclusive	Painted	No	=90°	Medium	Yes	Yes	415	1.0	45
West Bay Area Blvd at IH-45 (NB)	Exclusive + Exclusive	Painted	Channelized	=90°	Large	Yes	Yes	700	2.6	50
West Bay Area Blvd at IH-45 (EB)	Exclusive + Exclusive	Raised pavement markers	No	=90°	Large	Yes	Yes	134	0.6	40
Sherwin St at Washington Ave (WB)	Exclusive + Shared through/right-turn	Painted	No	>90°	Large	No (leftside) Yes (curb)	No	250	1.0	45
Shepherd Dr at IH-10 (WB)	Exclusive + Shared through/right-turn	Painted	No	=90°	Medium	Yes	No	327	4.5	45
Kirby Drive at IH-610 (WB)	Exclusive + Shared through/right-turn	Painted	Channelized	=90°	Large	Yes	No	676	4.5	45

### ***Lane Encroachment Conflicts***

According to the traffic conflicts counts presented in Table 5-5, the sites with high encroachment counts include Westcott Street at Memorial Drive, US 59 at SH 6, West Bay Area Boulevard at EB IH-45 frontage road, Sherwin Street at Washington Avenue, and Kirby Drive at IH-610.

The dual right-turn lanes on Sherwin Street at Washington Avenue have the highest rate of lane encroachment conflicts. This intersection is a three-legged skewed intersection with a turning angle of about 150 degrees. As a result, drivers tend to keep relatively high speeds when turning at such a great angle, and this makes it difficult to stay in their lanes.

The dual right-turn lanes on Kirby Drive at IH-610 also have a high rate of lane encroachment conflicts. It was noticed during the field conflict study that this intersection has a significant amount of heavy vehicles. In addition, this intersection is channelized with a relatively small turning roadway width (30 ft). Therefore, heavy vehicles usually could not stay in their lanes.

The dual right-turn lanes on West Bay Area Boulevard at the EB IH-45 frontage road site have the same rates of lane encroachment conflicts as Kirby Drive at IH-610. It is probably due to the low traffic volume at this location. The West Bay Area Boulevard approach is connected to an entrance ramp to access IH-45, and this location has low traffic volumes. As a result, drivers tend to drive with less caution here.

On the dual right-turn lanes on US 59 at SH 6, lane encroachment conflicts, although not very frequent, can be a problem due to the turning angle and high heavy vehicle volume.

Based on these observations, the following findings can be summarized:

- A skewed intersection with a turning angle significantly greater than 90 degrees usually has a higher potential of lane encroachments. Drivers tend to keep relatively high speeds in the geometric conditions, thus it is difficult to stay in lanes.
- Channelization with a narrow turning roadway (less than or equal to 30 ft) may contribute to a high rate of lane encroachments at dual right-turn lanes.
- Low traffic volume is responsible for frequent lane encroachments, since drivers tend to be less cautious under these traffic conditions.

### ***Rear-End Conflicts***

Kirby Drive at IH-610 is a location with frequent rear-end conflicts. As shown in Figure 5-5, a short receiving lane (150 ft) for the curb right-turn lane is provided at this site; vehicles are required to merge immediately after turning right onto Kirby Drive. Therefore, the right-turn vehicles may have to slow down when there are no acceptable gaps on the left side receiving lane. The succeeding vehicles that are proceeding at relatively high speeds will be exposed to a rear-end collision risk. The recommended solution is to provide sufficiently long receiving lanes (longer than 150 ft) for both of the dual right-turn lanes.

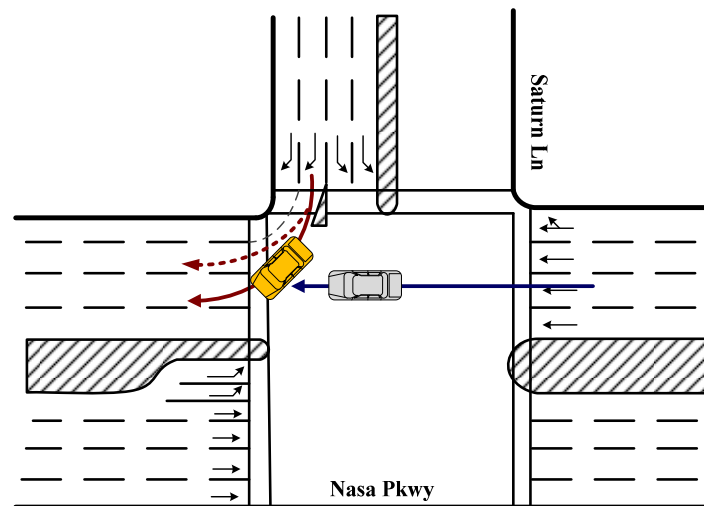
### ***Cross-Movement Conflicts***

Saturn Lane at SB NASA Parkway had a high cross-movement conflict count. According to the field observations, the following factors contributed to cross-movement conflicts at this location:

- Unclear turning guide line pavement markings.

- Three optional receiving lanes for the left side turning lane.

There is only one short, worn-out turning guide line between the curbside and left side turn lanes. From the left side right-turn lane, vehicles can turn to any of the three receiving lanes on NASA Parkway. In some cases, when a vehicle intends to turn to the second-right lane on NASA Parkway, it might mistakenly turn into the middle lane or the leftmost lane, as show in Figure 5-15. If the vehicle turns on red, the driver is exposed to the cross-street vehicles proceeding on NASA Parkway.



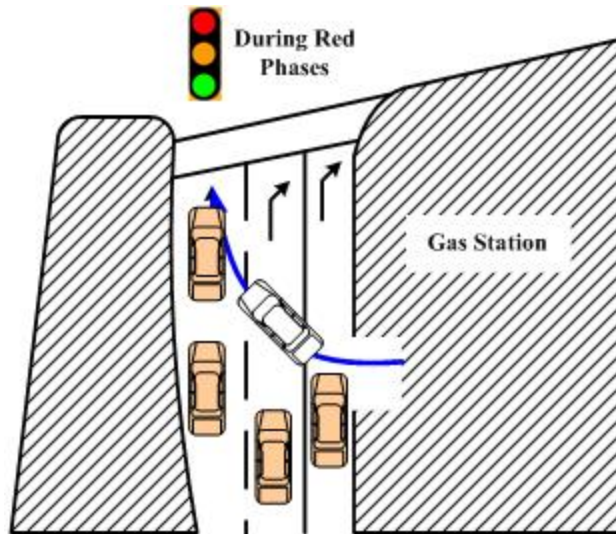
**Figure 5-15. Dual Right-Turn Lanes with Significant Numbers of Cross-Movements (Saturn Lane at NASA Parkway).**

The recommended solutions for preventing cross-movement conflicts at this location could be:

- Provide clear turning guide lines for both sides of the left side right-turn lane when the number of the receiving lanes is more than the turn lanes.
- RTOR is not recommended for the left side right-turn lanes, when the number of receiving lanes is greater than two.

### ***Lane Blockage Conflicts***

According to the traffic conflict counts presented in Table 5-5, two lane blockage conflicts were observed at the dual right-turn lanes at the Shepherd Drive at IH-10 site. It was observed in the field that, if an access point (driveway) is present near dual right-turn lanes, there is a high possibility that during the red phase, vehicles from the nearby access point will block one or more lanes due to improper lane change maneuvers toward the target through lane (see Figure 5-16).



**Figure 5-16. Illustration of Lane Blockage.**

The potential solution for this type of conflict is that design engineers should avoid installing dual right-turn lanes near major access points (e.g., from large gas stations, parking lots, or other traffic generators).

### **Summary of the Field Traffic Conflict Study**

In the field traffic conflict study, four types of traffic conflicts were investigated, and the contributing factors to each type were identified. Based on the findings, the following recommendations are provided:

- Clear turning guide lines are highly recommended for both sidelines of the left side right-turn lane when the intersection has a turning angle greater than 90 degrees.
- Small turning roadway widths (less than or equal to 30 ft) should not be used at dual right-turn lanes with channelization.
- RTOR is not recommended for the left side right-turn lane when there are more than two receiving lanes.
- If an auxiliary receiving/acceleration lane is provided for the curb right-turn lane at channelized dual turn lanes, its length should not be less than 150 ft.
- Design engineers should avoid installing dual right-turn lanes near major access points (e.g., from gas stations, parking lots, or other traffic generators).

Note that recommendation 1 is consistent with the results of the collision diagram analysis, and the other recommendations are new findings that can complement the collision diagram analysis.

## **5.4 COMPARISON STUDY**

As part of the efforts to evaluate safety performance of triple left- and dual right-turn lanes, the comparison study described in this section compared the crash experience of the selected triple left-turn (or dual right-turn) lanes to that of the single left-turn (or right-turn) lanes. Crash frequency and crash severity were compared.

Three types of comparisons of safety performance were conducted:

- Dual right/triple left-turn lanes were compared to single exclusive turn lanes at the same study locations (on the approaches other than the dual turn lanes).
- Before and after analyses were conducted for selected dual right/triple left-turn movements.
- Dual right-turn lanes were compared against single turn lanes at similar intersections.

### **Dual Right/Triple Left-Turn Lanes Compared to Single Right/Dual or Single Left-Turn Lanes at the Same Study Intersections**

To investigate whether the use of dual right/triple left-turn lanes will result in safer movements than traditional single right/dual or single left-turn lanes, the researchers compared the crash frequency and crash severity of both lanes.

#### ***Crash Severity Comparison Method***

At each intersection, the crash severity of dual right/triple left-turn related crashes and single right/dual or single left-turn related crashes were compared in terms of percentage of injury caused by crashes, which is calculated as:

$$P_1 = N_{1\_injury} / N_1 \quad (1)$$

where:

$P_1$  = Percentage of crashes with injury related to dual right/triple left-turn lanes in an intersection.

$N_{1\_injury}$  = Number of crashes with injury caused by dual right/triple left-turn lanes related crashes in the intersection.

$N_1$  = Total number of crashes related to dual right/triple left-turn lanes in the intersection.

$$P_0 = N_{0\_injury} / N_0 \quad (2)$$

where:

$P_0$  = Percentage of crashes with injury related to single right/dual or single left-turn lanes at an intersection.

$N_{0\_injury}$  = Number of crashes with injury caused by crashes related to single right/dual or single left -turn lane in the intersection.

$N_0$  = Total number of crashes related to single right/dual or single left -turn lane in the intersection.

In this crash severity comparison, if  $P_1$  is not higher than  $P_0$ , it indicates that dual right-turn lanes do not cause more severe crashes than conventional turn lane design.

#### ***Crash Severity Results***

The crashes involved in the collision diagram-based study were further analyzed. The breakdown of various crash severities is shown in Table 5-7 for the 20 dual right-turn intersections and in Table 5-8 for the five triple left-turn intersections. No fatal crashes happened during the analysis period. The results in Table 5-7 indicate that crashes related to dual right-turn traffic have the same percentage of person injuries as single right-turn lanes at the same intersections. The results in Table 5-8 indicate that the percentage of injury caused by crashes related to triple left-turn lanes is less than that related to other left-turn lane traffic.

**Table 5-7. Severity of Crashes at Dual Right-Turn Lanes  
(20 Locations, 6-Year Period).**

	Fatalities	Injuries	Property Damage Only	% of Injury
Crashes Related to Single RT Lanes	0	83	209	28.4%
Crashes Related to Dual RT Lanes	0	47	118	28.5%

**Table 5-8. Severity of Crashes at Triple Left-Turn Lanes (5 Locations, 6-Year Period).**

	Fatalities	Injuries	Property Damage Only	% of Injury
Crashes Related to Triple LT Lanes	0	8	14	36.4%
Crashes Related to Dual or Single LT Lanes	1	26	27	48.2%

The results imply that when a single right/dual or single left-turn related crash occurs, dual right/triple left-turn lanes do not contribute to more serious consequences.

***Crash Frequency Comparison Method***

The crash frequencies of the dual right/triple left-turn approaches of the study intersections were also compared with the crash frequencies of the single right/dual or single left-turn approaches at the same intersections. At each study intersection, the crash frequencies of dual right-turn lane and single right-turn lane approaches are calculated as:

$$F_1 = N_1 / n_1 \tag{3}$$

where:

- $F_1$  = Crash frequency of dual right/triple left-turn lanes.
- $N_1$  = Number of crashes related to the dual right/triple left-turns.
- $n_1$  = Number of dual right/triple left-turn approaches in the intersection.

$$F_0 = N_0 / n_0 \tag{4}$$

where:

- $F_0$  = crash frequency of single right/dual or single left-turn lanes.
- $N_0$  = number of crashes related to the single right/dual or single left-turn lanes.
- $n_0$  = number of single right/dual or single left-turn approaches in the intersection.

Note that the major reasons for comparing the crash frequencies between the different types of right-turn lanes at the same intersections are:

- At the same intersections, the traffic and driver population distributions typically have similar characteristics.
- The dual right/triple left-turn lanes usually have higher traffic volumes than the single right/dual or single left-turn lanes at same locations. Thus, if the crashes related to single right/dual or single left-turn lanes occurred more frequent than that related to dual right/triple left-turn lanes, it can be concluded that single right/dual or single left-turn lanes are less safe than dual right/triple left-turn lanes.

***Crash Frequency Results***

The crash statistics of the study intersections are presented in Tables 5-9 and 5-10.

**Table 5-9. Frequency of Crashes at Dual Right-Turn Lanes  
(20 Locations, 6-Year Period).**

Average # of Crashes Related to Single RT Lanes, $F_0$	Average # of Crashes Related to Dual RT Lanes, $F_1$
11.7	9.2

**Table 5-10. Frequency of Crashes at Triple Left-Turn Lanes (5 Locations, 6-Year Period).**

Average # of Crashes Related to Dual or Single LT Lanes, $F_0$	Average # of Crashes Related to Triple LT Lanes, $F_1$
7.7	5.5

The results in Tables 5-9 and 5-10 imply that dual right/triple left-turn lanes do not cause more crashes than single right-turn lanes/dual or single left-turn lanes.

**Before and After Crash Experience Study in Houston**

Currently, the *before* data are available for Houston only from Houston-Galveston Area Council (HGAC) for the period 1998–2001. Implementation dates are known for three dual right-turn lanes and one triple left-turn lane in Houston, as shown in Table 5-11.

**Table 5-11. Implementation for Study Intersections in Houston.**

Type	Intersection	Implementation Date
Dual RT Lanes	Shepherd Dr at IH-10	2002
	Kirby Dr at IH-610	2003
	Saturn Ln at NASA Pkwy	January 1995
Triple LT Lanes	Westcott St at Memorial Dr	January 1995

The crash records available for these intersections include data CRIS provided for the period 2003 to 2008 and HGAC from 1998 to 2001. Considering the implementation dates, only the first two intersections listed in Table 5-12 have crash records available both before and after the known implementation dates, as shown in Table 5-11.

**Table 5-12. Number of Crashes Before and After  
Dual Right-Turn Implementation in Houston.**

Average annual crash counts for the whole intersection (250 ft)		
	Before (per year, 1998–2001)	After (per year, 2003–2008)
Shepherd Dr at IH-10	9	32
Kirby Drive at IH-610	15	30
Crash counts in Dual RT lane direction		
	Before (single, 1998–2001)	After (dual, 2003–2008)
Shepherd Dr at IH-10	1	2
Kirby Drive at IH-610	0	5
Percentage of crash counts in Dual RT lane direction		
Shepherd Dr at IH-10	11.1%	6.3%
Kirby Drive at IH-610	0.0%	16.7%



The crash history shows that the annual average crash rates have significantly increased at both intersections, probably due to increased traffic demands. However, on Shepherd Drive at IH-10, the percentage of dual right-turn lanes-related crashes has decreased. Thus, the dual right-turn lanes do not cause safety problems at this location. On the other hand, along Kirby Drive at IH-610, the percentage of dual right-turn lanes-related crashes has increased significantly, which may indicate that the dual right-turn lanes are responsible for the total crash growth at this intersection. This result is also consistent with the results of the field conflict study (Table 5-5).

To investigate the safety impacts of dual right-turn lanes after implementation at the Kirby Drive/IH-610 site, the research team retrieved crash counts during the first six months of operation (see Table 5-13). In Table 5-13, the yellow cell indicates the implementation period, and the red cell indicates the crash counts in the first six months of implementation.

**Table 5-13. Crash Counts for Each Six-Month Period.**

Intersections	2003		2004		2005		2006		2007		2008	
IH-610 at Kirby Drive	0	1	0	0	1	0	0	0	0	0	0	2

Table 5-13 shows it is not evident that the impact of dual right-turn lanes in the first six months after implementation is greater than the time periods later.

### **Comparison of Crash Experience with Single Right-Turn at Similar Intersections**

Historical data were also explored for enabling comparisons of safety performance between dual right-turn and single right-turn lanes at similar intersections. Currently, these data are available for three urban areas; Austin, Houston, and Sugar Land, as shown in Table 5-14.

**Table 5-14. Overall Crash Experience of Dual Right-Turn Lanes  
and Comparative Single Right-Turn Lanes.**

	Intersection Name	AADT	Crash count related to subject RT movement	Intersection total crash count	% of subject RT movement crash count
<b>Austin</b>					
Dual RT Lanes	Spicewood Springs Rd at Loop 360	61,810	0	22	0.0
Single RT Lanes	William Cannon Blvd at Manchaca Rd	63,500	1	86	1.2
	Brodie Ln at William Cannon Blvd	71,860	3	97	3.1
	45th St at Lamar Blvd	52,270	1	49	2.0
	Parmer Rd at Lamar Blvd	84,670	5	196	2.6
	Barton Springs Rd at Lamar Blvd	64,710	2	65	3.1
<b>Houston</b>					
Dual RT Lanes	Kirby Drive at IH-610	47,281	12	181	6.6
	Saturn Ln at NASA Pkwy	64,242	0	1	0.0
	Shepherd Dr at IH-10	35,802	3	190	1.6
	Sherwin St at Washington Ave	67,233	3	134	2.2
Single RT Lanes	Kirby Dr at US 59	255,210	2	348	0.6
	NASA Pkwy at Space Center Blvd	66,672	1	13	7.7
	Shepherd Dr at Memorial Dr	129,082	1	39	2.6
	Washington Ave at Houston Ave	61,962	1	31	3.2
<b>Sugar Land</b>					
Dual RT Lanes	US 59 at SH 6	273,470	17	612	2.8
Single RT Lanes	Willams Trace Blvd at Lexington Blvd	64,890	1	59	1.7
	SH 6 at Lexington Blvd	81,070	3	163	1.8

Table 5-14 shows that the right-turn lanes sites are grouped based on intersection AADT levels, and Table 5-15 shows that the group average crash rates are calculated. Also in Table 5-15, the results indicate that for median volume intersections, dual right-turn lanes had a better safety performance than single right-turn lanes at similar locations. At low volume intersections, single right-turn lanes presented a better safety performance. The sample sizes are very small to be conclusive for low volume level intersections.

**Table 5-15. Overall Crash Experience of Dual Right-Turn Lanes and Comparative Single Right-Turn Lanes (Part II).**

Median AADT Volume					
Intersections with Dual RT Lanes	Roadway Type	No. of Dual RTs	AADT	Dual RT-related crash rate (per movement)	Average
Spicewood Springs Rd at Loop 360	Arterial	1	61,810	0	1
Saturn Ln at NASA Pkwy	Arterial	1	64,242	0	
Sherwin St at Washington Ave	Frontage	1	67,233	3	
Intersections with Single RT Lanes	Roadway Type	No. of Single RTs	AADT	RT related crash rate (per movement)	Average
William Cannon Blvd at Manchaca Rd	Arterial	4	63,500	1	2.1
Brodie Ln at William Cannon Blvd	Arterial	4	71,860	3	
Parmer Rd at Lamar Blvd	Arterial	4	84,670	5	
NASA Pkwy at Space Center Blvd	Arterial	2	66,672	1	
Barton Springs Rd at Lamar Blvd	Arterial	4	64,710	2	
Washington Ave at Houston Avenue	Arterial	4	61,962	1	
Williams Trace Blvd at Lexington Blvd	Arterial	4	64,890	1	
SH 6 at Lexington Blvd	Arterial	4	81,070	3	
Low AADT Volume					
Intersections with Dual RT Lanes	Roadway Type	No. of Dual RTs	AADT	Dual RT-related crash rate (per movement)	Average
Kirby Dr at IH-610	Frontage	1 (4 in all)	47,281	12	7.5
Shepherd Dr at IH-10	Frontage	1 (1 in all)	35,802	3	
Intersections with Single RT Lanes	Roadway Type	No. of Single RTs	AADT	RT-related crash rate (per movement)	Average
45 <sup>th</sup> St at Lamar Blvd	Arterial	4	52,270	1	1

**Conclusions and Recommendations**

The comparison study indicates that, collectively, the safety experience of dual right-turn lanes is similar to, or better than, single exclusive right-turn lanes. It can be concluded that, generally, a well-designed dual right-turn lane does not result in significantly higher crash frequency or severity compared to a single exclusive right-turn lane. According to the safety performance of the limited use of triple left-turn lanes in Texas, this design alternative does not raise any major safety issues.

## 5.5 SUMMARY OF SAFETY PERFORMANCE EVALUATION

This report documents the major findings through:

- A collision diagrams-based study.
- A field traffic conflict study.
- A comparison study.

The research team investigated the safety experience of a total of 20 dual right-turn and five triple left-turn lanes in Texas, and conducted a field traffic conflict study to supplement the crash history analysis. The results reveal that the use of triple left-turn lanes in Texas does not raise any major safety issues. It can also be concluded that, generally, a well-designed dual right-turn lane does not cause significantly higher crash frequency or severity compared to a single right-turn lane. In addition, the following recommendations are provided:

- Clear turning guide lines are highly recommended for both sides of the left side right-turn lane when the intersection has a turning angle greater than 90 degrees.
- Narrow dual right-turn lanes (turning roadway width is less than or equal to 30 ft) with channelization should not be used.
- RTOR is not recommended for the left side right-turn lane when there are more than two receiving lanes.
- If an auxiliary receiving/acceleration lane is provided for the curb right-turn lane at channelized dual turn lanes, its length should not be less than 150 ft.
- Design engineers should avoid installing dual right-turn lanes near access points (e.g., from gas stations, parking lots, or other traffic generators).
- For closely spaced intersections, if a downstream intersection uses dual right-turn lanes, the curb right-turn lane should not be aligned with any through lane at the upstream intersection.
- Turning radii should be not less than 25 ft at dual right-turn lanes.
- The use of channelization should be carefully studied for dual right-turn lanes.

## 5.6 REFERENCES

Abdel-Aty, M., X. Wang, and J.B. Santos. Identifying Intersection-Related Traffic Crashes for Accurate Safety Representation, *ITE Journal, Institute of Transportation Engineers*, vol. 79, no. 12, pp. 38 – 44, December 2009.

## **CHAPTER 6**

### **GEOMETRIC DESIGN GUIDELINES**

The research team developed these guidelines to provide a resource for assisting in the decision-making process related to dual right and triple left-turn projects. The recommended guidelines should provide a starting point when installation of a dual right-turn or a triple left-turn configuration is being considered for implementation.

#### **6.1 GEOMETRIC DESIGN GUIDELINES FRAMEWORK**

Researchers based the preferred practices on a thorough review and comprehensive synthesis of the state-of-the-art findings associated with the design and operation of dual right-turn and triple left-turn lanes. Additionally, the web-based survey sent to selected agencies around the country provided state-of-the-practice knowledge related to current design, installation, experience, and operation of dual right-turn and triple left-turn lanes. The research team organized the guidelines into two categories with three sub-areas for each:

- Dual Right-Turn Lanes
  - Operational Design Guidance.
  - Installation Design Guidance.
  - Geometric Design Guidance.
- Triple Left-Turn Lanes
  - Operational Design Guidance.
  - Installation Design Guidance.
  - Geometric Design Guidance.

The remainder of this chapter synthesizes the preferred practice for each of the two categories. The research team highlighted the recommended guidelines for the multi-turn lane configurations in Texas for easy reference (see shaded text boxes).

The research team discovered that guidance related to dual right-turn and triple left-turn lane configurations remains limited due to the relatively new design concept. However, these two multi-turn lane configurations are slowly being recognized for application in some urban areas of Texas to accommodate the increasing turning demand volumes. The guidelines suggested in this research should be utilized where dual right-turn or triple left-turn lane configurations are being considered for use. This guidance is a tool developed to assist the engineer by providing additional knowledge that can be used to make informed decisions concerning the design and operation of multi-turn lane configurations. The research team agrees with TxDOT's decision to incorporate this guidance in the next update of the TxDOT *Roadway Design Manual*.

#### **6.2 GEOMETRIC DESIGN GUIDANCE FOR DUAL-RIGHT TURN LANES**

High volumes of right-turning vehicles may support a dual right-turn lane configuration to increase capacity for the turns while reducing delay for other movements at the intersection. Dual right-turn lanes can reduce both the length needed for the dual right-turn lanes and the

corresponding green time needed for that movement. Dual right-turn movements may be in the form of either two exclusive right-turn lanes or one exclusive right-turn lane and a shared through-right-turn lane. These guidelines will assist the engineer with design and operational procedures needed to implement consistent dual right-turn lanes.

### **Operational Design Guidance**

Operational design guidance refers to those aspects related to the operational characteristics associated with dual right turn configurations. Approaches with right-turn volumes that cannot be accommodated in a single turn lane without excessively long green times (and delays for other approaches) may be appropriate locations for double turn lanes (Signalized Intersections 2004). The research team did not find any volume-based guidance or existing warrant for when dual right-turn lanes should be implemented. In the absence of existing guidance, researchers felt that the existing warrant and volume-based guidance for implementation of dual left-turn lanes is a good threshold for dual right-turn lanes. Based on this belief, Guideline 1 indicates that it is appropriate to consider dual right-turn configuration when forecasted right-turn volumes approach 300 vehicles per hour. In addition to this volume threshold, transportation agencies should consider the following items when considering additional right-turn lanes:

- Planning should account for the widening of all approaches for lane alignment.
- Examine weaving and merging/diverging issues.
- Consider nearby access points and destinations and necessary adjustments.

**Guideline 1: Traffic signal-controlled intersection approaches with forecasted right-turn volumes approaching 300 vehicles per hour (vph) should receive consideration for use of a dual right-turn configuration.**

*Source: 0-6112 project*

### **Installation Design Guidance**

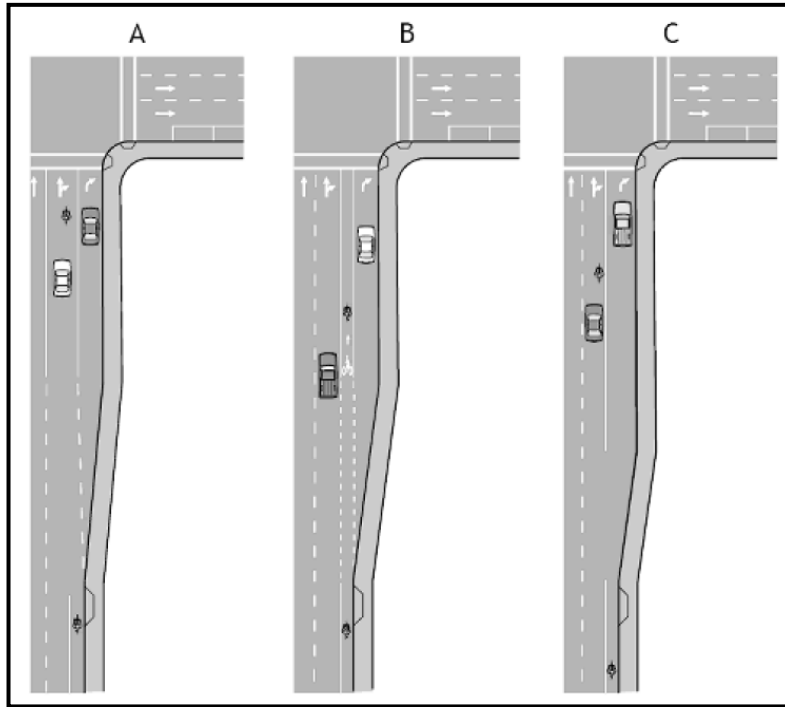
Installation design guidance refers to the roadway delineation and roadway signage used for dual right-turn configurations.

**Guideline 2: Dual right-turn lanes are particularly difficult for bicyclists and pedestrians and should be provided only if absolutely necessary.**

*Source: University Course (2006)*

The design for single right-turn lanes allows bicyclists and pedestrians to cross paths with motorists in a predictable manner, but the addition of an optional through lane from which cars may also turn right adds complexity. Some drivers may make a last-minute decision to turn right from the optional through-right-turn lane without signaling, thus surprising bicyclists and pedestrians.

Several approaches to bike lane design with dual right-turn lanes are provided in Figure 6-1. Alternative A encourages cyclists to share the optional through-right-turn lane with motorists. This helps to minimize confusion between cyclist and motorist. Alternative B guides cyclists up to the intersection in a dedicated bike lane. However, the motorist must be aware of any cyclists in the bike lane prior to turning. Alternative C allows cyclists to choose a path themselves (this design is the AASHTO recommendation—simply dropping the bike lane prior to the intersection). Engineering judgment should be used to determine which design is most appropriate for the situation.



**Figure 6-1. Dual Right-Turn with Bicycle Lane.**

### **Geometric Design Guidance**

Geometric design guidance refers to those aspects related to the geometrical characteristics associated with dual right-turn configurations.

**Guideline 3:** The minimum lengths for various dual right-turn lane geometrics should be determined based on the speed (in mph) as shown in the following table:

Speed (mph)	Deceleration Length (ft)	Taper Length (ft)	Storage length (ft)
30	160	100	100
35	215	100	100
40	275	100	100
45	345	150	100
50	425	150	100
55	510	150	100

Source: Roadway Design Manual (2010)

As with single right-turn lanes, the design vehicle should be considered when determining the deceleration length, taper length, and storage length of the turn lane (Signalized Intersections 2004). The departure lane should accommodate the turning radius of a large vehicle. Additionally, delineation of the turn path will assist in guiding drivers through the maneuver and help reduce crossing over into adjacent lanes while turning.

**Guideline 4:** Dual right-turn lanes require a larger intersection radius (usually 75 ft or more) and a throat width comparable to a dual left-turn configuration.

Source: Location and Design Manual (2010)

The normal width of two travel lanes may be insufficient to properly receive two vehicles turning side by side because of the off-tracking characteristics of turning vehicles. Thus, the receiving throat width may need to be widened. For instance, with 90-degree intersections, one can expect that the throat width for dual right-turn lanes will be approximately 30–36 ft. If the angle of turn is less than 90 degrees, it may be acceptable to provide a narrower width.

It can be assumed that if a paved shoulder is present, then the available throat width will include the paved shoulder and can be used to accommodate two-abreast turns. It is also desirable to have a center median on the receiving leg of the turn to provide good definition of the entry throat area.

If a 30- or 36-ft throat width is provided to receive dual turn lanes, planners and engineers should consider how this will affect the through traffic approaching from the other side. The through lanes should line up relatively well to ensure a smooth flow of traffic through the intersection (Connecticut DOT 2009).

**Guideline 5:** Dual right-turn lane consideration should take into account an adjacent upstream intersection that is in close proximity.



Dual right-turn lanes located downstream from a closely spaced intersection may operate poorly and/or impact safety. An adjacent upstream intersection that is located in close proximity to the dual right-turn lane configuration may trap an unknowing motorist that does not want to turn right, but wants to continue through the intersection. The unknowing motorist may stop to change lanes to continue in the through lane. This, in turn, can lead to increased delay to upstream motorists and/or increase the potential for rear-end crashes in the right-turn lanes. Engineering judgment should be used to determine whether a dual right-turn lane configuration is appropriate for each potential site.

### 6.3 GEOMETRIC DESIGN GUIDANCE FOR TRIPLE LEFT-TURN LANES

A high demand of left-turning vehicles may support a triple left-turn lane configuration to increase the capacity for the left turns while reducing delay for other movements at the intersection. Triple left-turn lanes can reduce both the length needed for the left-turn lanes and the corresponding green time needed for that movement. These guidelines will provide the engineer with consistent design and operational procedures needed to implement triple left-turn lanes.

#### Operational Design Guidance

Operational design guidance refers to those aspects related to the operational characteristics associated with triple left-turn configurations.

**Guideline 6: Traffic signal controlled intersection approaches with forecasted left-turn volumes approaching 600 vph should receive consideration for use of a triple left-turn configuration.**

*Source: Qureshi et al. (2004) and Courage et al. (2002)*

When considering additional turn lanes, planning should account for the widening of all approaches for lane alignment, examine weaving and merging/diverging issues, and consider nearby access adjustments. Additionally, the use of grade separation to accommodate volumes exceeding the triple turn threshold should be considered to account for the long run-out length of at-grade triple left-turn lane geometrics.

**Guideline 7: For planning purposes, forecasted left-turn saturation flow rate estimates ranging between 1,761–2,079 vphgpl should receive consideration for use of a triple left-turn configuration.**

*Source: Perez-Cartagena and Tarko (2005)*

Major factors that significantly influence saturation flows are the approach grade of the turning lanes, whether the intersection is skewed or right angled and whether the intersection has curved or straight approaches (Sando and Moses 2009). An intersection with a downgrade and a skewness with a left-turn angle of less than 90 degrees can cause high saturation flows due to increased speeds in turning. On the other hand, curved triple left-turn lanes and triple left-turn

lanes on one-way streets will have lower saturation flows due to lower speeds of vehicles having to make sharper turns.

**Guideline 8: For triple left-turn consideration, analysis must take into account the effects of adjacent intersections and downstream attractions that may affect lane utilization.**

*Source: Courage (2002)*

Vehicles turning left might position themselves on a particular lane, depending on their immediate downstream destination such as turning left or right to a shopping center. Also, if there is a bus stop with no bus turnout immediately on the downstream side of triple left-turn lanes, drivers may position themselves away from the lane leading directly to bus stop in order to avoid being stuck behind the bus that is loading or unloading passengers (Sando and Moses 2009). The *Highway Capacity Manual* should be used for operational analysis only when there are no complicating effects from the adjacent intersections. Otherwise, a microscopic simulation should be performed.

**Guideline 9: An operational analysis of the intersection should be provided that indicates that the provision of a triple left-turn lane would correct a situation in which the overall capacity of the intersection would be seriously deficient, and that no other geometric or signal modifications would correct the deficiency.**

*Source: Transportation Design Procedures (2007)*

According to the City of Irvine Transportation Design Procedures, the operational analysis should take into account the effects of adjacent intersections, including:

- Backup from a downstream signal on the receiving roadway.
- Turning movement distribution at a downstream intersection that would compromise the ability of the receiving lanes to store the left turning vehicles.
- Heavy volumes from other approaches that are also accommodated by the roadway that receives the left turns.
- Upstream effects that could make it difficult to distribute the approaching left turns over the three left-turning lanes (e.g., a heavy single lane exit ramp from a freeway).

**Guideline 10: The use of triple left-turn lanes should be considered only when the safety record (number and type of collisions) at the intersection suggests that the proposed operation would not aggravate a demonstrated safety problem or when no problems regarding bicycle and pedestrian safety are evident.**

*Source: Courage et al. (2002)*

Attention should be given to the signal timing plans that are sensitive to bicycle and pedestrian requirements, including the Walk and Do Not Walk clearance intervals for pedestrians, and the yellow and all red intervals for bicycles. Considering the increased roadway width, the signal-

timing plan must be able to provide adequate Walk and Do Not Walk clearance intervals for all phases that accommodate through movements (Courage et al. 2002).

### Installation Design Guidance

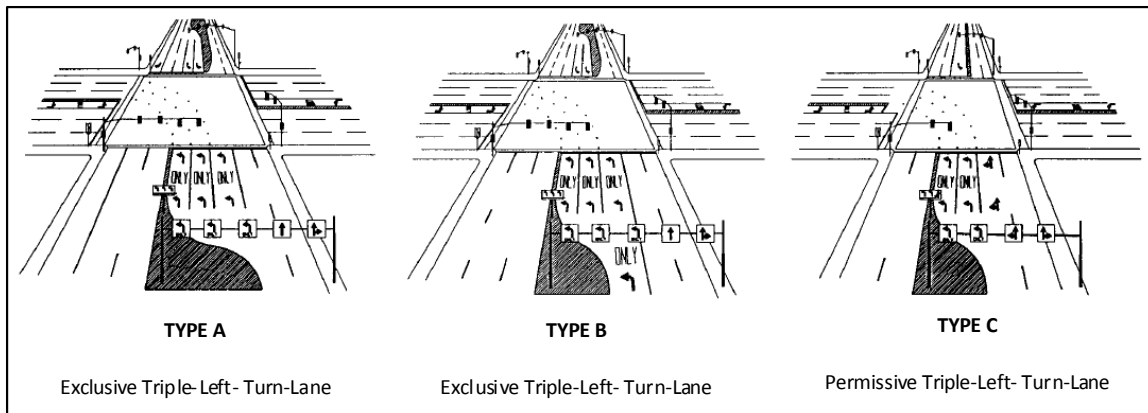
Installation design guidance refers to the roadway delineation and roadway signage used for triple left-turn configurations.

**Guideline 11: Recommended practice for use of pavement markings and overhead signage for triple left-turn configurations should consider the following:**

- Dotted (Skip) line pavement marking should be used.
- Advance overhead signage should be used to inform drivers of lane options.
- There should be no conditions that obscure or result in confusing pavement marking within the intersection.
- Each turn lane should be marked with turn arrows and “ONLY” legends as appropriate.

*Source: Akeret (1994) and Courage et al. (2002)*

Three triple left-turn lane configurations are shown in Figure 6-2, which provides the various geometric and delineation features of each. Type A is the recommended configuration because it helps reduce trap lanes associated with Type B configurations and to avoid the operation complexities of an optional through and left-turn lane associated with Type C configurations.



**Figure 6-2. General Triple Left-Turn Lane Delineation.**

**Guideline 12: Recommended practice for using traffic signal control systems in triple left-turn configurations should consider the following:**

- All three left-turn lanes should be provided with a signal indication over each turning lane.
- A secondary left-turn signal head may be needed at the far side of the intersection.

*Source: Akeret (1994) and Yu (2008)*

**Guideline 13:** Triple left-turn lanes are NOT appropriate where:

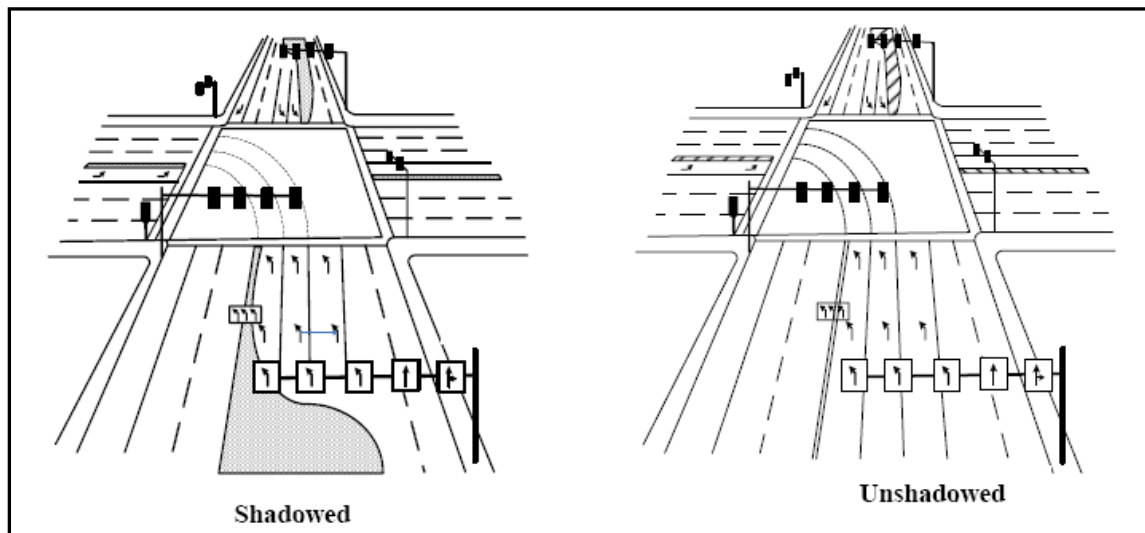
- A high number of vehicle-pedestrian conflicts occur.
- Left-turning vehicles are not expected to evenly distribute themselves among the lanes.
- Channelization may be obscured.
- Sufficient right-of-way is not available to provide for the design vehicle.

Source: *Transportation Design Procedures (2007)*

Triple left-turn lanes could adversely affect existing access locations, such as the preclusion of previously possible left-turn access to and from adjacent properties. Therefore, triple left turn lanes require more specific justification and more attention to detail in the design than for double left-turn lanes (Transportation Design Procedures 2007).

### Geometric Design Guidance

Geometric design guidance refers to those aspects related to the geometrical characteristics associated with triple left-turn configurations. Triple left-turn lane approaches can have either a shadowed configuration (one lane provides access to all three left turning lanes) or an unshadowed configuration (each left turn lane is accessed directly by an upstream lane) as shown in Figure 6-3. Typically, the innermost lanes of a shadowed intersection are less utilized while the innermost lanes of an unshadowed intersection are highly utilized (Sando and Moses 2009). Other factors such as upstream geometrics may also influence lane utilization of the triple left-turn lanes.



**Figure 6-3. Triple Left-Turn Lane Configurations.**

To assist the engineer in designing a triple left-turn lane configuration, certain minimum guidance should be considered for approaches and departures. Each intersection design will include different design criteria. Additional issues that may need to be considered for the design of a triple left-turn configuration and that are not included in these guidelines should include engineering judgment that results in the best possible design outcome.

**Guideline 14:** The following geometric design guidance should be used as a recommended practice on *APPROACHES* for triple left-turn configurations.

<b>Design Vehicle</b>	<b>As a minimum, use a single unit vehicle (SU) and two passenger vehicles (P) turning simultaneously with a minimum 4 ft separation between the swept paths of the vehicles.</b>
<b>Lateral clearance</b>	<b>Minimum = 2 ft</b>
<b>Clearance between opposing left turns</b>	<b>Minimum lateral vehicle body clearance = 10 ft</b>
<b>Width of approach lane</b>	<b>Minimum Width = 11 ft Desirable Width = 12 ft</b>
<b>Storage bay length</b>	<b>Based on anticipated left-turn arrival rates, cycle length, need to prevent spillover to through lanes, and presence of adjacent upstream intersections and driveways.</b>
<b>Approach taper length</b>	<b>Based on design speed and local preference for reverse curves versus taper sections.</b>

Source: Akeret (1994) and Courage et al. (2002)

**Guideline 15:** The following geometric design guidance should be used as a recommended practice on *DEPARTURES* for triple left-turn configurations.

<b>Width of departure lane</b>	<b>Minimum Width=11 ft Desirable Width=12 ft</b>
<b>Departure length</b>	<b>Three downstream lanes should be available for at least 300 ft from the intersection.</b>
<b>Median design</b>	<b>The receiving leg should have a raised median island of at least 2 ft in width.</b>
<b>Throat width</b>	<b>The clear portion of the intersection may need to be widened based on the design vehicle turning characteristics.</b>

Source: Akeret (1994) and Yu et al. (2008)

Proper attention must be paid to accommodating traffic in multiple left-turn lanes as it leaves the intersection. The exit roadway must have enough lanes to accommodate the left turns and pedestrian crosswalks should be clearly marked. Pedestrian signals should always be used for any crosswalk in which pedestrians will encounter protected left turns, regardless of the number of lanes (Florida Intersection Design Guide 2007).

## 6.4 REFERENCES

Ackeret, K. W. Criteria for the Geometric Design of Triple Left-Turn Lanes. *ITE Journal, Institute of Transportation Engineers*, vol. 64, no. 12, pp. 27–33, December 1994.

*Traffic Control Signal Design Manual*, Connecticut Department of Transportation, Bureau of Engineering and Construction, Division of Traffic Engineering, 2009. [Online] <http://www.ct.gov/dot/lib/dot/documents/dtrafficdesign/sigmanapproved2009.pdf> . Link Accessed January 28, 2011.

Courage K., B. Stephens, A. Gan, and M. Willis. *Triple Left-Turn Lanes at Signalized Intersections*. Publication Research Report for Florida Department of Transportation, December 2002.

*Florida Intersection Design Guide*, Florida Department of Transportation, 2007. [Online] <http://www.dot.state.fl.us/rddesign/FIDG-Manual/FIDG2007.pdf>. Link Accessed August 9, 2010.

*Location and Design Manual*, Section 400—Intersection Design. Ohio Department of Transportation, 2010. [Online] [http://www.dot.state.oh.us/Divisions/ProdMgt/Roadway/roadwaystandards/Location%20and%20Design%20Manual/entire%20manual\\_oct10.pdf](http://www.dot.state.oh.us/Divisions/ProdMgt/Roadway/roadwaystandards/Location%20and%20Design%20Manual/entire%20manual_oct10.pdf). Link Accessed August 9, 2010.

Perez-Cartagena, R. I., and Tarko, A. P. *Calibration of Capacity Parameters for Signalized Intersections in Indiana*. *Journal of Transportation Engineering*, 2005.

Qureshi, M., G. Spring, V. R. Malkayigari, and J. Rathod. *Assessment of Multiple Left-Turn Phasing Strategies*. Publication Report No. RDT 04-003, Missouri Department of Transportation, January 2004. [Online] <http://library.modot.mo.gov/RDT/reports/Ri02014/RDT04003.pdf>. Link Accessed January 28, 2011.

*Roadway Design Manual*, Texas Department of Transportation, May 2010. [Online]: <http://onlinemanuals.txdot.gov/txdotmanuals/rdw/rdw.pdf>. Link Accessed August 10, 2010.

Sando, T., and Moses, R. *Influence of Intersection Geometrics on the Operation of Triple Left-Turn Lanes*. *Journal of Transportation Engineering*, May 2009.

*Signalized Intersections: Informational Guide*. Federal Highway Administration, Publication Report FHWA-HRT-04-091, August 2004. [Online] <http://www.fhwa.dot.gov/publications/research/safety/04091/04091.pdf> . Link Accessed January 28, 2011.

*Transportation Design Procedures*, City of Irvine, February 2007. [Online]  
<http://www.cityofirvine.org/civica/filebank/blobdload.asp?BlobID=10062> . Link Accessed  
January 28, 2011.

*University Course on Bicycle and Pedestrian Transportation—Lesson 15: Bicycle Lanes*.  
Federal Highway Administration, Publication Report FHWA-HRT-05-133, July 2006. [Online]:  
<http://www.fhwa.dot.gov/publications/research/safety/pedbike/05085/chapt15.cfm>  
Link Accessed August 9, 2010.

Yu L., Y. Qi, H. Yu, L. Guo and C. Chen. *Development of Left-Turn Operations Guidelines at  
Signalized Intersections*. Publication Report No. TxDOT 0-5840-1, Final report to Texas  
Department of Transportation (TxDOT), 2008.





## CHAPTER 7 SIGNAL DESIGN GUIDELINES

### 7.1 SIGNAL DESIGN GUIDELINES FRAMEWORK

The research team identified and investigated the specific issues and concerns in the signal design associated with triple left-turn and dual right-turn lanes. The results from previous tasks, including literature review, field studies, and safety assessment, are also incorporated for developing the guidance on signal design. The developed signal design guidance in this task consists of three parts: signal design guidance for multi-turn lanes, dual right-turn lanes, and triple left-turn lanes. This chapter highlights the recommended guidelines for multi-turn-lane configurations in Texas in shaded text boxes for easy reference.

### 7.2 SIGNAL DESIGN GUIDANCE FOR MULTI-TURN LANES

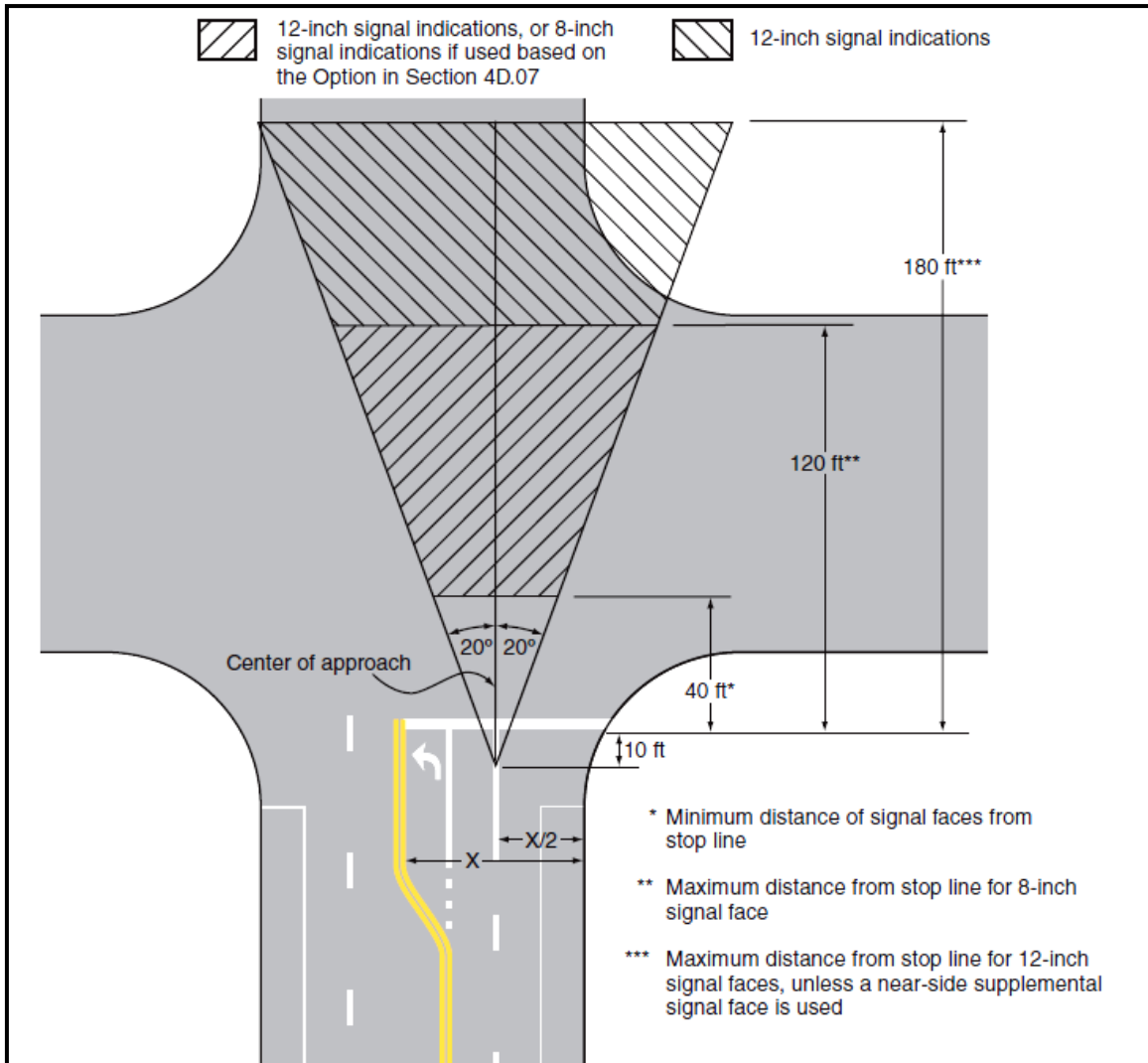
**Guideline 1 - Lateral Positioning of Signal Faces: If there is no through movement, the signal faces for triple left-turn and dual right-turn lanes on the approach shall be located between two lines intersecting with the center of the approach at a point 10 ft behind the stop line, one making an angle of approximately 20 degrees to the right of the center of the approach extended, and the other making an angle of approximately 20 degrees to the left of the center of the approach extended (See Figure 7-1).**

This guideline is based on the provision in Section 4D.13, *Manual on Uniform Traffic Control Devices*, 2009 Edition (MUTCD 2009).

**Guideline 2 - Longitudinal Positioning of Signal Faces: Except where the width of an intersecting roadway or other conditions make it physically impractical, the signal faces for each approach to an intersection or a midblock location shall be provided as follows:**

- 1) A signal face installed for triple left-turn lanes and dual right-turn lanes shall be located:
  - a) No less than 40 ft beyond the stop line.
  - b) No more than 180 ft beyond the stop line unless a supplemental near-side signal face is provided.
  - c) As near as practical to the line of the driver's normal view, if mounted over the roadway.
- 2) Where the nearest signal face is located between 150 and 180 ft beyond the stop line, engineering judgment of the conditions, including the worst-case visibility conditions, shall be used to determine if the provision of a supplemental near-side signal face would be beneficial (see Figure 7-1).

This guideline regarding longitudinal positioning of signal faces is based on the MUTCD provision in MUTCD (2009) (Section 4D.14). The MUTCD also requires that the signal face satisfying this requirement shall simultaneously meet the lateral placement requirement described in Guideline 1. Thus, signal faces shall be located in the shaded area in Figure 7-1.



**Figure 7-1. Lateral and Longitudinal Locations of Primary Signal Faces.**

*Source: MUTCD (2009)*

**Guideline 3 - Distance between Two Turn Signal Faces:** If more than one separate turn signal face is provided for a turning movement and if one or both of the separate turn signal faces are located over the roadway, the signal faces shall be located no less than 8 ft apart measured horizontally perpendicular to the approach between the centers of the signal faces.

This guideline is based on the provision in the MUTCD (Section 4D.13). It requires that the distance between the centers of two turn signal faces shall be no less than 8 ft measured horizontally perpendicular to the approach.

**Guideline 4 - Specific Placement Criteria of Signal Faces: Except for shared left-turn and right-turn signal faces, any primary signal face required for an exclusive turn lane should be located overhead approximately over the center of each exclusive turn lane.**

This guideline is based on the provision in the MUTCD (Section 4D.11).

**Guideline 5 - Number of Signal Faces Required For Triple Left-Turn and Dual Right-Turn Lanes: If two or more left-turn/right-turn lanes are used for a separately controlled left-turn/right-turn movement, or if a left-turn/right-turn movement represents the major movement from an approach, two or more primary left-turn/right-turn signal faces should be provided.**

This guideline is based on the requirements (Section 4D.10 and Section 4D.11) provided in the MUTCD.

**Guideline 6 - Signal Timing for Bicycles and Pedestrians at Triple Left-Turn or Dual Right-Turn Sites: Considering the increased roadway width at triple left-turn or dual right-turn sites, the signal timing plan must be able to provide adequate Walk and Do Not Walk clearance intervals for pedestrians, and provide adequate yellow and all red intervals for bicycles.**

This guideline is recommended based on the study of Courage et al. (2002).

**Guideline 7 - Traffic Signs: Advance overhead signs should be provided to inform drivers of lane options. These signs should be supplemented with appropriate downstream lane destination messages for reducing downstream weaving maneuvers.**

This guideline is according to Ackeret's recommendation (1994). Advance overhead signs (e.g., R3-8 in Figure 7-2) are recommended to be provided to inform drivers of lane options.



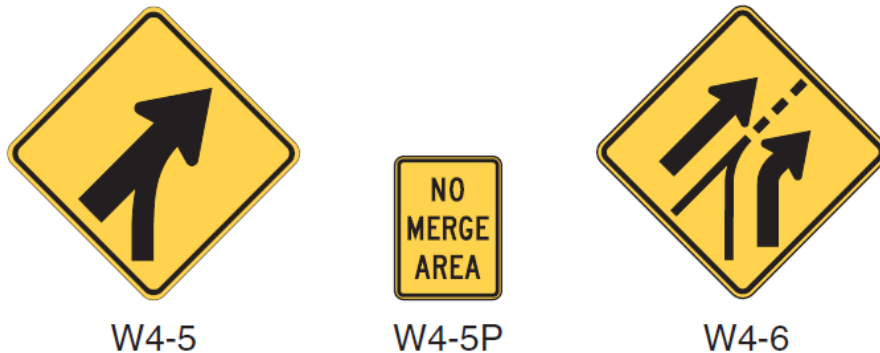
R3-8



**Figure 7-2. Advance Overhead Sign for Dual Right-Turn Lane.**

(Top: R3-8 sign from MUTCD, Bottom: Overhead sign at Commerce St/Weatherford St in Fort Worth)

In addition, supplemental signs with downstream lane configuration should also be provided to warn drivers to reduce downstream weaving maneuvers. For instance, an Entering Roadway Merge sign (W4-5) with a No Merge Area (W4-5P) supplemental plaque (Figure 7-3) mounted below it may be used to warn road users of an entering roadway in which they will encounter an abrupt merging situation. On the other hand, an Entering Added Lane sign (W4-6) (Figure 7-3) should be installed in advance of a point where two roadways converge and merging movements are not required.



**Figure 7-3. Supplemental Signs with Downstream Lane Configurations.**

*Source: MUTCD (2009)*

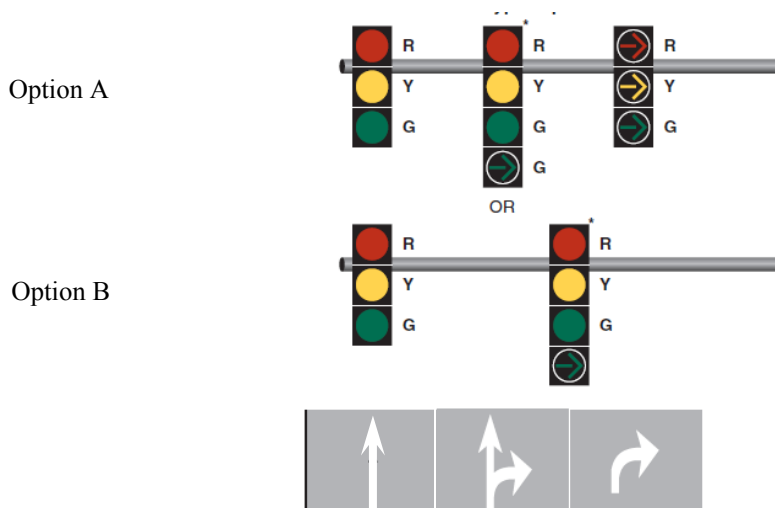
### 7.3 SIGNAL DESIGN GUIDANCE FOR DUAL RIGHT - TURN LANES

**Guideline 8 - Typical Positions and Arrangements of Shared Signal Faces for Protected Only Mode Right Turns:**

1. If the outer right-turn lane is shared by through and right-turn traffic, then the typical positions and arrangements of shared signal faces for protected only mode right turns are shown in Figure 7-4.
2. If the outer right-turn lane is shared by left-turn and right-turn traffic, then the typical positions and arrangements of shared signal faces for protected-only mode right turns are shown in Figure 7-5 and Figure 7-6.

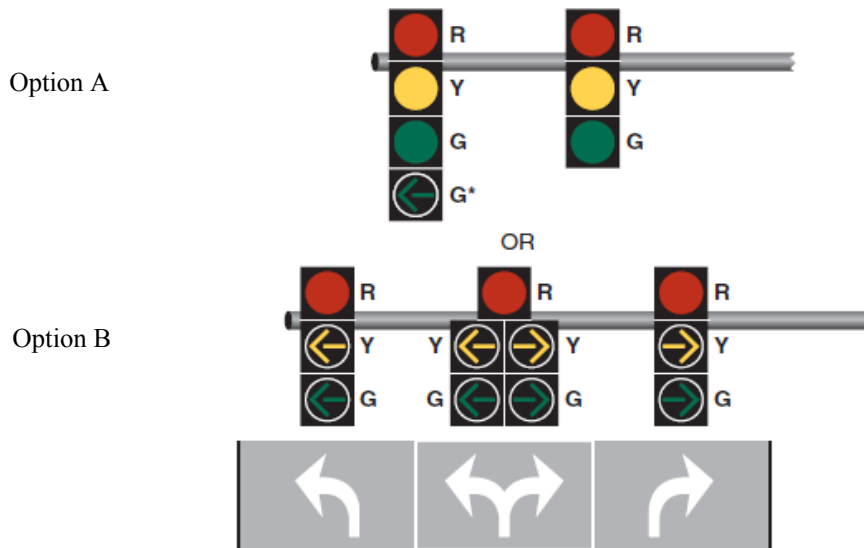
This guidance is based on the provisions in MUTCD. If the outer right-turn lane is shared by through and right-turn traffic, the typical positions and arrangements of shared signal faces for protected only mode right-turn lanes could be either Option A or Option B as shown in Figure 7-4.

If the outer right-turn lane is shared by left-turn and right-turn traffic, the typical positions and arrangements of shared signal faces for protected only mode right-turn lanes could be either Option A or Option B in Figures 7-5 or 7-6. In Figure 7-5, the signal indications are used for right-turn lanes, particularly when there are no conflicting vehicular or pedestrian movements. In Figure 7-6, the signal indications are for dual right-turn lanes when there are pedestrians or vehicles conflicting with right turn movement.



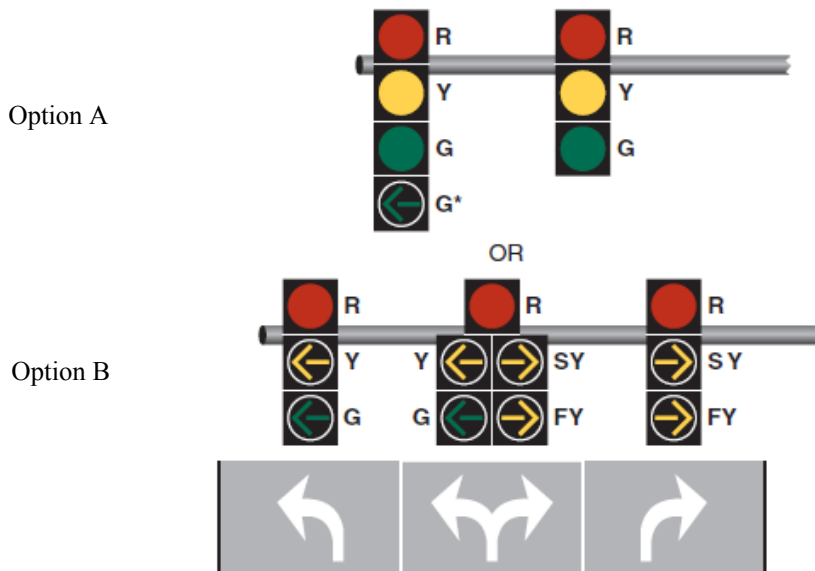
**Figure 7-4. Typical Positions of Shared Signal Faces for Protected-Only Mode Right Turns.**

*Source: MUTCD (2009)*



**Figure 7-5. Signal Indications for Approaches with a Shared Left-Turn/Right-Turn Lane and No Through Movement or Conflicting Vehicular or Pedestrian Movements.**

*Source: MUTCD (2009)*

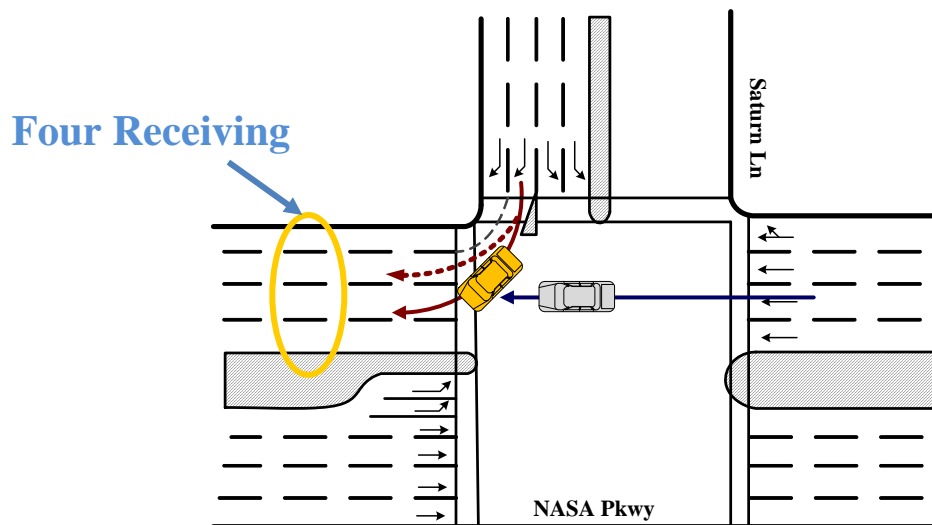


**Figure 7-6. Signal Indications for Approaches with a Shared Left-Turn/Right-Turn Lane and No Through Movement with Pedestrian or Vehicular Conflicts.**

*Source: MUTCD (2009)*

**Guideline 9 - Right Turn On Red (RTOR) for Lane 1: RTOR is not recommended for Lane 1, when the number of the receiving lanes is more than turning lanes (see Figure 7-7).**

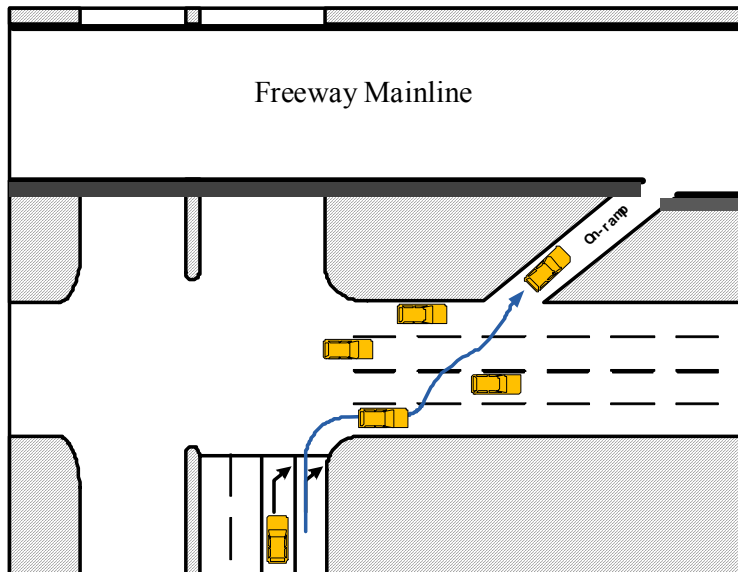
This recommendation is based on the field traffic conflict study conducted as part of this research. When the vehicles in Lane 1 (designated in Figure 4-5) have more than one receiving lane to turn into (see Figure 7-7), they might randomly choose one of the lanes, which will result in the cross street vehicles conflicting with the unexpected right-turning vehicles during RTOR periods.



**Figure 7-7. Saturn Lane at NASA Parkway.**

**Guideline 10 - RTOR for Both Right-Turn Lanes: RTOR is not recommended for both of the right-turn lanes (Lane 1 and Lane 2) at channelized dual right-turn lanes when there is an entrance ramp at the nearby downstream location.**

This guideline is based on field observations conducted as part of this research. At an intersection approach with dual right-turn lanes, if an entrance ramp is located on the intersecting cross-street and is in close proximity to the intersection, RTOR from both of the right-turn lanes (i.e., Lane 1 and Lane 2) is not recommended because of both safety and operational considerations. Vehicles turning right on red from either lane to access the entrance ramp may result in conflicts with cross-street through vehicles (see Figure 7-8). In some cases RTOR could be allowed if there is sufficient distance—250 ft per lane change is needed to access the entrance ramp—available to safely accommodate the anticipated weaving movement. The dual right-turn lane at Precinct Line Road at SH 183 in Hurst is an example of where RTOR is allowed from Lane 2 (the lane nearest the curb) because the westbound Precinct Line entrance ramp to SH 183 is located approximately 500 ft downstream on the two-lane frontage road. Figure 7-9 provides a series of photographs of this site showing the existing signs and markings.



**Figure 7-8. Dual Right-Turn Lanes with an Entrance Ramp at the Nearby Cross-Street Downstream Location.**



**Figure 7-9. Precinct Line at SH 183 Dual Right-Turn Lane Signs and Markings.**

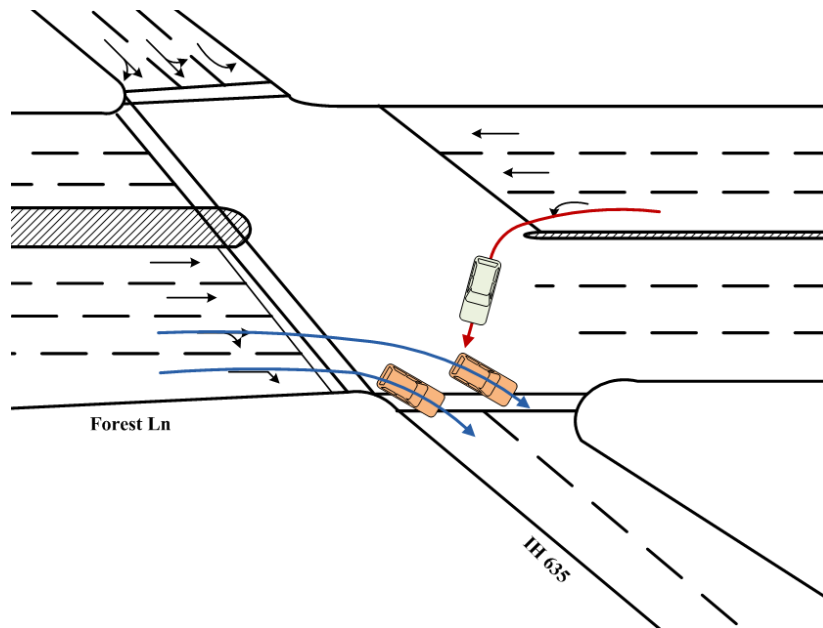
Top: SB lanes exclusive dual-right turn lane  
 Bottom: Sign 1 'NO TURN ON RED EXCEPT FROM RIGHT LANE' and  
 Sign 2 'RIGHT TURN ON RED-RIGHT LANE ONLY'



**Guideline 11 - Protected-Permissive Left Turn (PPLT) Signal Control Mode for Opposing Approach: PPLT is not recommended for the opposing approach when right-turn and opposing left-turn traffic share the only two receiving lanes (see Figure 7-10).**

This guideline is developed based on Deskins's study (2009). The PPLT operation, as currently defined in the MUTCD, has a protected left turn interval indicated by a green arrow and a permissive left-turn interval indicated by a circular green indication, during which the left turn must yield to the opposing traffic.

If the opposing traffic of the dual right turn lane approach is under PPLT left-turn operation mode and there are only two receiving lanes for the dual right-turn traffic and opposing left-turn traffic, then during the permissive left-turn phase, it would be difficult for the opposing left-turn vehicles to find a gap between the right-turn vehicles to enter the receiving lanes. In this case, the opposing left-turn vehicles might become trapped at the center of the intersection even after the traffic light turns green for cross-street through traffic, which could cause danger to both the cross-street through vehicles and the opposing left-turn vehicles.



**Figure 7-10. Forest Lane at IH-635.**

**Guideline 12 - Traffic Signs:** A No Turn On Red From This Lane (with a down arrow) (R10-11d) sign may be mounted directly over the center of the lane, from which turns on red are prohibited (see Figure 7-11).

This guideline is according to the MUTCD (2009) requirement. It recommended using No Right Turn On Red signs when RTOR for one or two of the right-turn lanes are not allowed. There are a number of signs and operational strategies available in addition to the sign shown in Figure 7-11. Additional static signs are shown in Figure 7-12 and an example electronic blank-out sign that can be activated during specific time periods to restrict right-turns is provided in Figure 7-13.

In the State of Texas, the rules and regulations for driving are contained in the Texas Transportation Code (TTC). The rules and regulations for how drivers are lawfully permitted to operate at traffic signals are provided in TTC, Title 7 (Vehicles and Traffic), Subtitle C (Rules of the Road), Chapter 544 (Traffic Signs, Signals, and Markings). Appendix C provides a copy of this section of the TTC. With regard to RTOR, TTC Section 544.007 (d) states the following:

*An operator of a vehicle facing only a steady red signal shall stop at a clearly marked stop line. In the absence of a stop line, the operator shall stop before entering the crosswalk on the near side of the intersection. A vehicle that is not turning shall remain standing until an indication to proceed is shown. After stopping, standing until the intersection may be entered safely, and yielding right-of-way to pedestrians lawfully in adjacent crosswalk and other traffic lawfully using the intersection, the operator may:*

- (1) Turn right; or*
- (2) Turn left, if the intersecting streets are both one-way streets and a left-turn is permissible.*



R10-11d

**Figure 7-11. No Turn on Red Sign R10-11d.**

*Source: MUTCD (2009)*

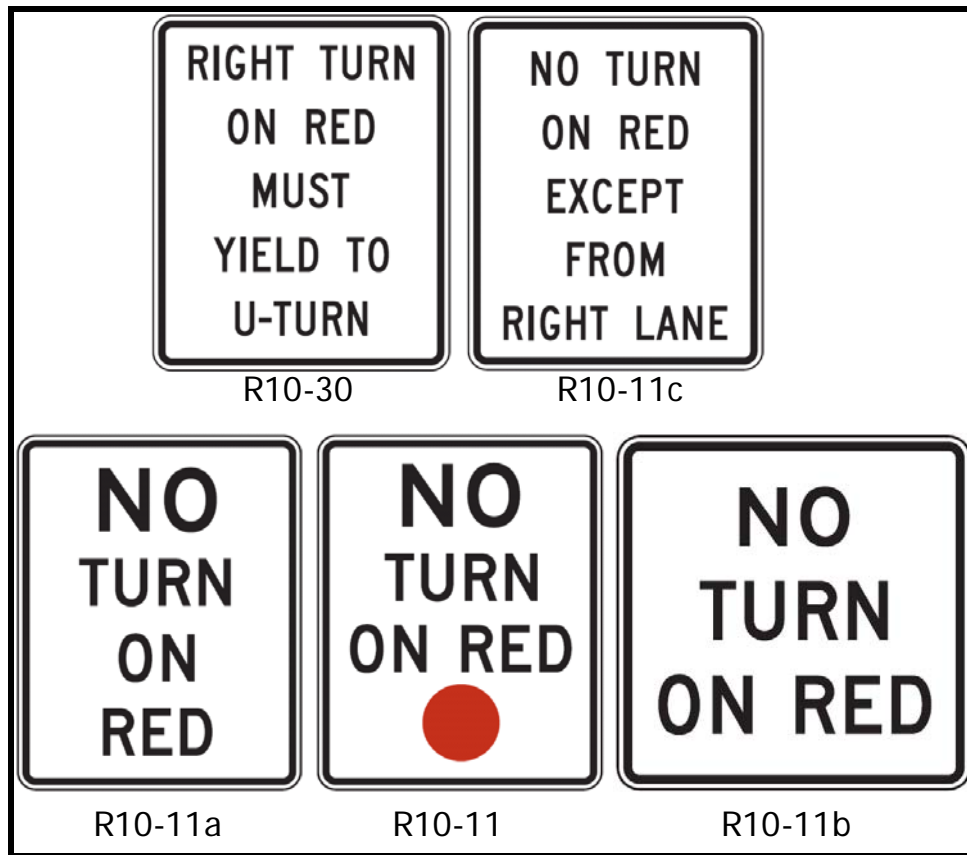


Figure 7-12. Other Sign Options for Prohibiting Right-Turn on Red Movements.



Figure 7-13. Blank-Out Signs Used to Control Right-Turn Movements by Time of Day.  
(Left: Off-mode vs. Right: Active-mode where right turns are prohibited)

## 7.4 SIGNAL DESIGN GUIDANCE FOR TRIPLE LEFT-TURN LANES

**Guideline 13 - Left-Turn Signal Control Mode: A fully protected signal phase is recommended for triple left-turn lanes. However, PPLT is also allowed based on traffic engineers' judgments.**

This guideline is developed based on the studies of the Institute of Transportation Engineers, Florida Section (1982), Courage et al. (2002), Qureshi et al. (2004), and Deskins (2009). According to the recommendations of the Institute of Transportation Engineers, Florida Section (1982), permissive movements should not be allowed for multiple left-turn lanes. In addition, the studies of Courage et al. (2002) and Qureshi et al. (2004) both agree that protected-only signal control mode should be used for triple left-turn lanes. On the other hand, according to Deskins (2009), PPLT works quite well at some dual left-turn sites. Therefore, this guideline recommends using fully protected signal phase for triple left-turn lanes; PPLT is only allowed based on traffic engineers' judgments.

**Guideline 14 - The Number of Signal Indications for Triple Left-Turn Lanes: All three left-turn lanes should be provided with a signal indication over each turn lane.**

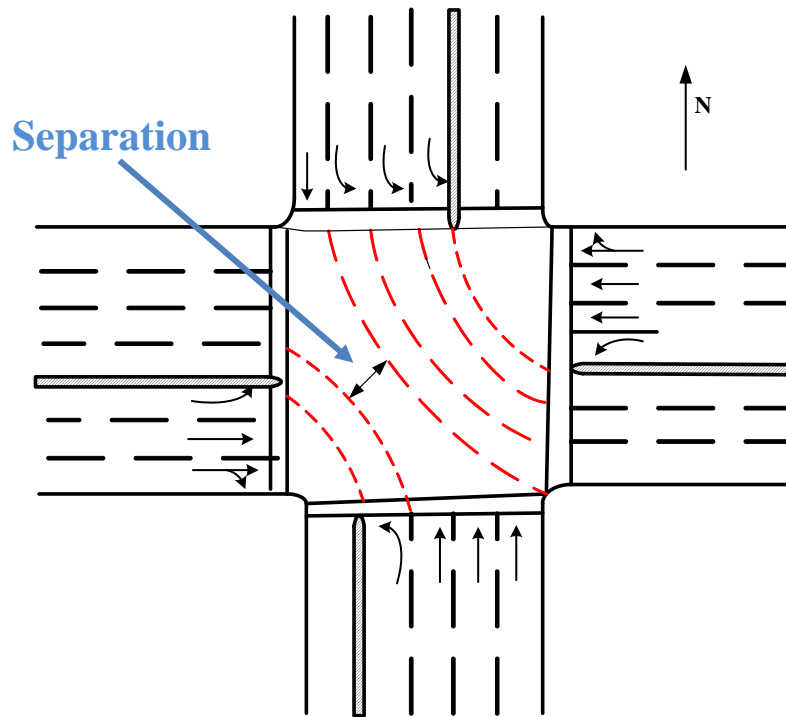
This guideline is provided based on Ackeret's recommendation (1994).

**Guideline 15 - Split Phasing For Shared Left-Turn Lane on Two-Way Streets: On two-way streets, if the triple left-turn lanes have a shared left/through outer lane, split phasing of the signal operation is required to prevent interactions between left-turn and through movements.**

This guideline is recommended based on the findings in Yu et al. (2008) and Ackeret (1994).

**Guideline 16 - Lead-Lag Sequence Will Be Necessary under Certain Conditions: Lead-lag sequence will be necessary if adequate separation (at least 10 ft) cannot be guaranteed for concurrent opposing left turns (See Figure 7-14).**

This guideline is based on Ackeret's recommendations (1994). It recommended that concurrent opposing left turns should have at least 10 ft separation (see Figure 7-14). If geometric conditions do not allow concurrent opposing left-turns, separate left-turn phases (i.e., lead-lag sequence), should be used for the triple left-turn sites.



**Figure 7-14. Separation between Concurrent Opposing Left-Turns.**

**Guideline 17 - Secondary Left-Turn Signal Head: If the intersection with offset or has long clearance distance, a secondary left-turn signal head may be needed at the far side of the intersection.**

This guideline is based on the study of Yu et al. (2008). When intersections with triple left-turn lanes are comparatively large or have long clearance distance, there would be a need to place an extra left-turn signal head at the far-side corner of the intersection, to better guide left-turning vehicles across the intersection as they make their turns.

## 7.5 REFERENCES

Ackeret, K. W. Criteria for the Geometric Design of Triple Left-Turn Lanes, *ITE Journal, Institute of Transportation Engineers*, vol. 64, no. 12, pp. 27–33, December 1994. Online: [http://turnlanes.net/files/criteria\\_for\\_the\\_geometric\\_design\\_of\\_triple\\_left-turn\\_lanes.pdf](http://turnlanes.net/files/criteria_for_the_geometric_design_of_triple_left-turn_lanes.pdf). Link Accessed October 25, 2010.

Courage K., B. Stephens, A. Gan, and M. Willis. *Triple Left-Turn Lanes at Signalized Intersections*, Publication Research Report for Florida Department of Transportation, December 2002. Online: [http://www.dot.state.fl.us/research-center/Completed\\_Proj/Summary\\_TE/FDOT\\_BC131rpt.pdf](http://www.dot.state.fl.us/research-center/Completed_Proj/Summary_TE/FDOT_BC131rpt.pdf). Link Accessed October 25, 2010.

Deskins, J. Five Years of Observations of the Flashing Yellow Arrow Display. ITE Meeting, 2009.

Federal Highway Administration, *Manual on Uniform Traffic Control Devices for Streets and Highways*, U.S. Department of Transportation. 2009.

Institute of Transportation Engineers, Florida Section. Left Turn Phase Design in Florida. *ITE Journal*, 52 (9), 28–35. 1982.

Qureshi, M., G. Spring, V. R. Malkayigari, and J. Rathod. Assessment of Multiple Left-Turn Phasing Strategies. Publication Report No. RDT 04-003, Missouri Department of Transportation, January 2004. Online:  
<http://library.modot.mo.gov/RDT/reports/Ri02014/brief.pdf>. Link Accessed October 25, 2010.

Yu L., Y. Qi, H. Yu, L. Guo and C. Chen. Development of Left-Turn Operations Guidelines at Signalized Intersections. Publication Report No. TxDOT 0-5840-1, Final Report to Texas Department of Transportation (TxDOT), 2008.

## **CHAPTER 8**

### **KEY FINDINGS AND RECOMMENDATIONS**

This research project achieved two primary goals:

- Evaluated the operational (Chapter 4) and safety performance (Chapter 5) of triple left-turn (TLT) and dual right-turn (DRT) sites in Texas.
- Developed geometric (Chapter 6) and signal design (Chapter 7) guidelines for TLT and DRT lanes.

The research team performed five primary tasks to fulfill the project goals:

- Reviewed existing guidelines and practices regarding TLT and DRT lanes.
- Identified important factors that affect the design, operation, and safety of TLT and DRT lanes through a survey of transportation professionals.
- Completed studies of existing TLT and DRT sites to document design issues and concerns, operational performance, and safety performance.
- Developed geometric and signal design criteria (e.g., lane/throat widths, pavement markings, storage bay length, positioning/placement of signal faces, traffic signs).
- Synthesized criteria for determining when TLT or DRT lanes can be installed.

#### **8.1 SUMMARY OF KEY FINDINGS**

Researchers found that published studies are very limited regarding the design and operation of TLT lanes and almost nonexistent for DRT lanes. There is a lack of detailed guidance for multiple turn lanes. Researchers received a good response from national and state agencies to determine which factors are important to TLT and DRT performance. Of 66 completed surveys, less than 25 percent indicated formal guidance on either type of multiple turn lane and only four respondents had done evaluations. The respondents indicated that the most important installation criteria were turn lane volumes, intersection capacity, adjacent development, and safety.

The field studies in Texas collected both static (e.g., lane widths, grades, pavement markings, traffic signs, upstream and downstream conditions, signal timing) and dynamic (e.g., volumes by lane, saturation flow, critical events) data in order to evaluate design and operational performance. Researchers collected these data at five TLT and 20 DRT lane sites, primarily in the Dallas–Fort Worth and Houston urban areas. Some key findings for TLT lanes:

- Lane utilization patterns were varied for each of the five sites studied.
- All sites were T-intersections with peak-hour volumes from 646 to 2,846 vehicles.
- Lighted pavement markers that were used to delineate the lane lines between the TLT lanes were effective at reducing violations and well received by the public at one site.
- Saturation flow rates in Texas were consistent with earlier published national values.

Some key findings of the operational analysis for DRT lanes were:

- Most vehicles use the outside lane (closest to the curb) to make their right turns.
- Peak-hour volumes ranged from a low of 200 to a high of almost 1,000 vehicles.

- Lane utilization (inside vs. outside) is comparable when the right-turn volumes are high.
- Saturation flow rates are higher in the inside lane [average = 1,717 vehicles per hour (vph) versus the outside lane at 1,668 vph] and also generally lower than those at TLT sites.
- Impact of trucks in the inside lane is greater than when in the outside lane.

Researchers evaluated safety performance by investigating the crash history of the 25 sites using three techniques: collision diagrams, field conflict study, and comparison study. The results revealed that TLT lanes do not experience any major safety issues and also concluded that, in general, a well-designed DRT lane does not cause significantly higher crash frequency or severity compared to single right-turn lanes.

## 8.2 PROJECT RECOMMENDATIONS

Based on this research, TxDOT and other agencies should be confident that well-designed TLT and DRT lanes can be implemented to address heavy turning demand at key intersections. The evaluation of these multiple turn lanes revealed that they perform well from both operational and safety standpoints. Some of the key recommendations based on the research include:

- TLT lanes should be considered when turning volumes exceed 600 vph.
- DRT lanes should be considered when turning volumes exceed 300 vph.
- Clear turning guide lines (a.k.a, ‘puppy tracks’) are highly recommended for both sides of the inside right-turn lane when the intersection has a turning angle greater than 90 degrees.
- Narrow DRT lanes (turning roadway  $\leq$  30 ft) with channelization should not be used.
- Right-turn on red is not advised for the inside lane when there are more than two receiving lanes.
- Designers should avoid installing DRT lanes near access points (e.g., corner gas stations).
- If an auxiliary receiving/acceleration lane is provided for the curb right-turn lane at channelized dual turn lanes, its length should not be less than 150 ft.
- For closely spaced intersections, if a downstream intersection uses dual right-turn lanes, the outside (curb) lane should not be aligned with any through lane at the upstream intersection.

TLT and DRT lanes are not appropriate for all situations, and an operational analysis should support their use. Other techniques (grade separation, signal timing) might be better solutions for a particular site, especially when considering the effects of adjacent intersections, pedestrian/bicycle movements, and other key factors. The researchers developed a product, 0-6112-P1, *Keys to Successful Public Outreach*, which is useful for implementing multiple turn lane projects. Table 8-1 provides the basic guidance framework for conducting public outreach for new TLT and DRT lanes.



**Table 8-1. Basic Guidance Framework for Outreach for Multiple Turn Lane Facilities.  
Public Outreach Guidance for Triple Left-Turn and Dual Right-Turn Lanes**

<b>Goals</b>	<b>Messages</b>	<b>Methods</b>
<ol style="list-style-type: none"> <li>1. Provide driver awareness</li> <li>2. Eliminate potential driver confusion</li> <li>3. Inform public of schedule and impacts</li> </ol>	<ol style="list-style-type: none"> <li>1. Becoming common throughout the United States</li> <li>2. Often used around major traffic generators</li> <li>3. Improve access and mobility at the intersection</li> <li>4. No indication of degraded safety performance</li> </ol>	<ol style="list-style-type: none"> <li>1. Multimedia presentation</li> <li>2. Project exhibits</li> <li>3. Press releases</li> <li>4. Television</li> </ol>



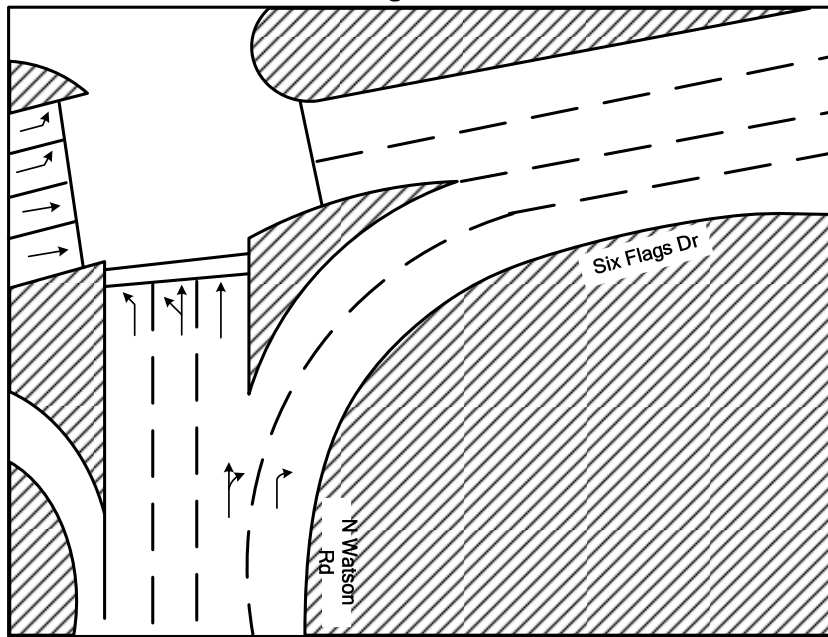
**APPENDIX A**

**COLLISION DIAGRAMS FOR  
DUAL RIGHT-TURN LANES**

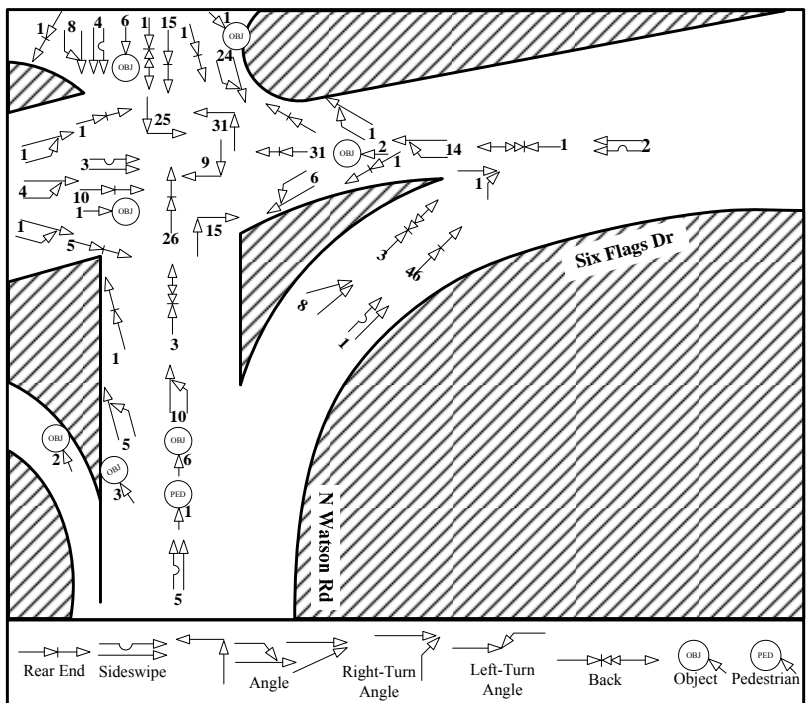


(AT 20 INTERSECTIONS)

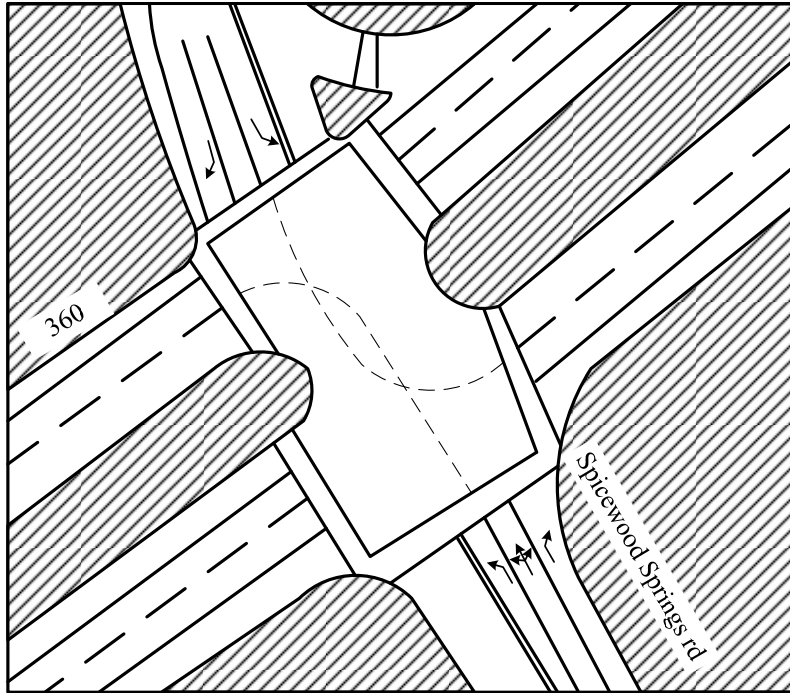
<b>City</b>	<b>Intersection Name</b>
Arlington	Six Flags Drive at SH 360
Austin	Spicewood Springs Road at Loop 360
Dallas	Lovers Lane at NB US 75
	Forest Lane at IH-635
	Preston Road at IH-635
	Galleria Road at NB Dallas North Tollway
	IH-35E at Continental Avenue
Frisco	Gaylord Parkway at NB Dallas North Tollway
	Warren Parkway at NB Dallas North Tollway
	Main Street at SB Dallas North Tollway
Grand Prairie	N. Carrier Parkway at Roy Orr Boulevard
Houston	Sherwin Street at Washington Avenue
	Saturn Lane at NASA Parkway
	Shepherd Drive at IH-10
	Kirby Drive at IH-610
Lewisville	Main Street/FM 1171 at IH-35E
Plano	Legacy Drive at NB Dallas North Tollway
San Antonio	Babcock Road at WB IH-410
	AT&T Center Parkway at IH-35
Sugar Land	US 59 at SH 6



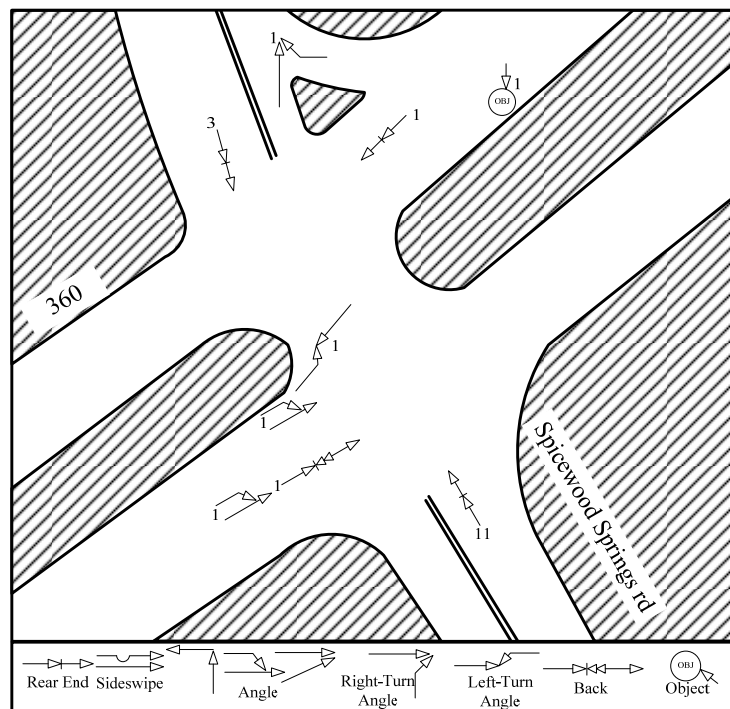
**Figure A-1. Intersection Layout: Six Flags Drive at SH 360, Arlington.**



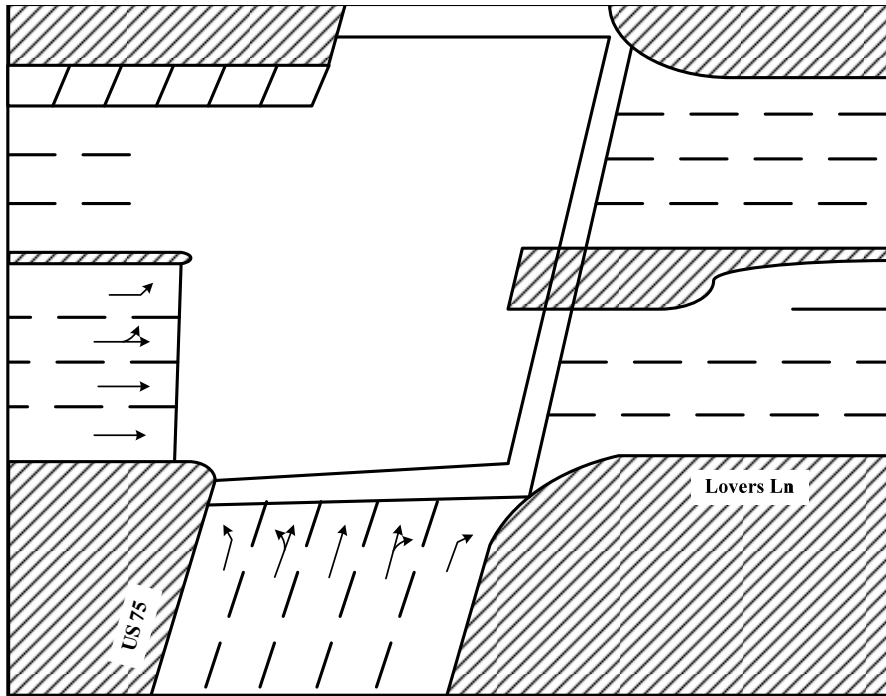
**Figure A-2. Collision Diagram: Six Flags Drive at SH 360, Arlington.**



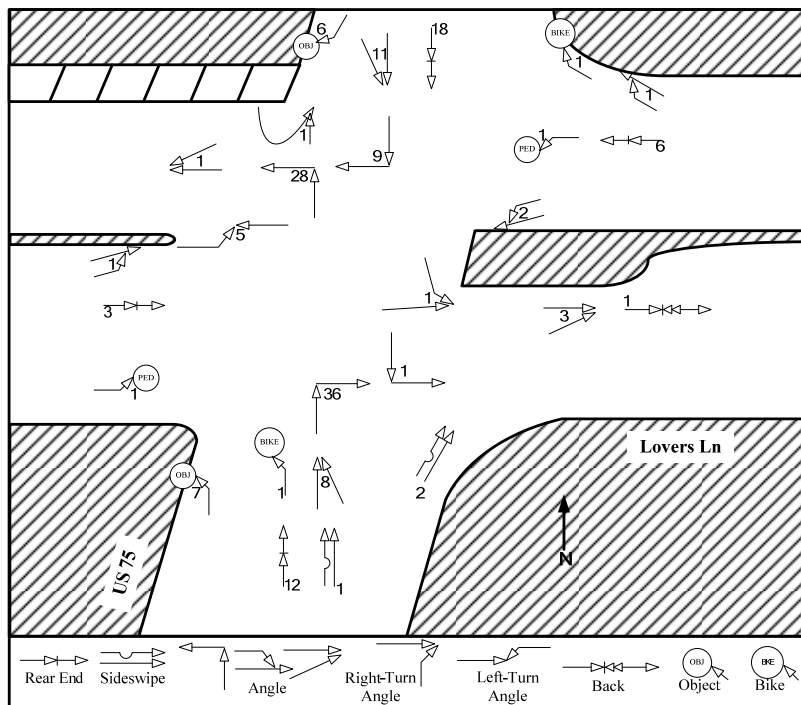
**Figure A-3. Intersection Layout: Spicewood Springs Road at Loop 360, Austin.**



**Figure A-4. Collision Diagram: Spicewood Springs Road at Loop 360, Austin.**



**Figure A-5. Intersection Layout: Lovers Lane at US 75, Dallas.**



**Figure A-6. Collision Diagram: Lovers Lane at US 75, Dallas.**



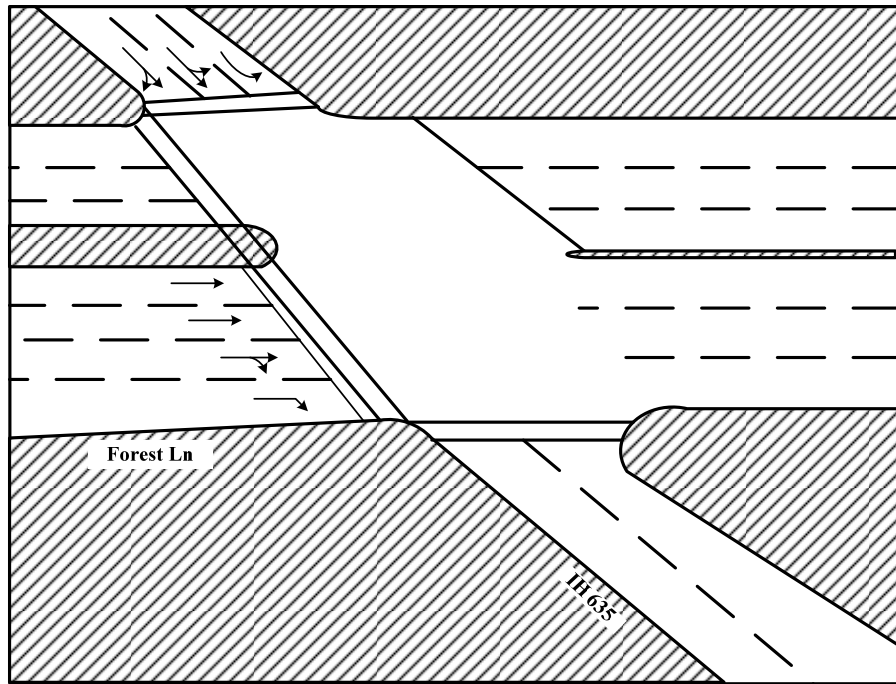


Figure A-7. Intersection Layout: Forest Lane at IH-635, Dallas.

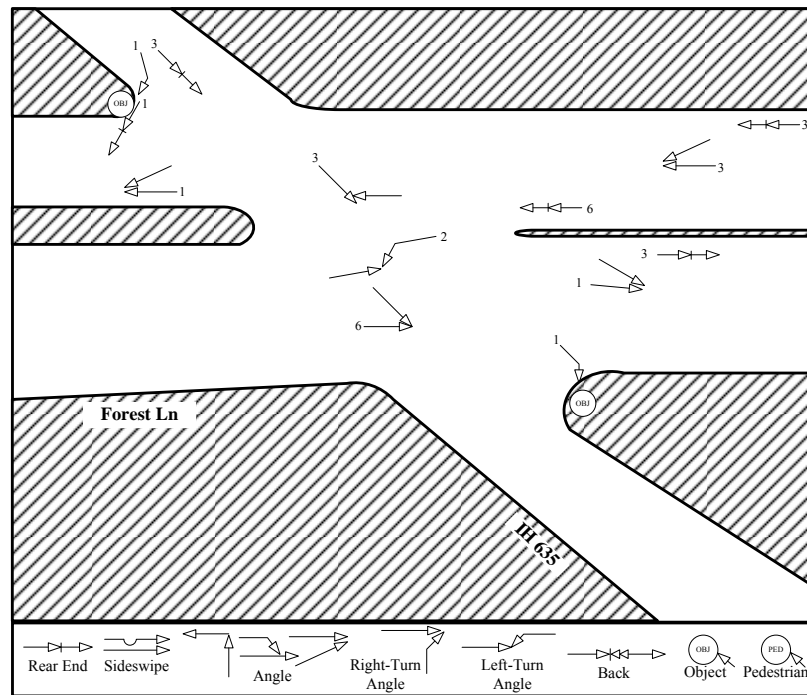
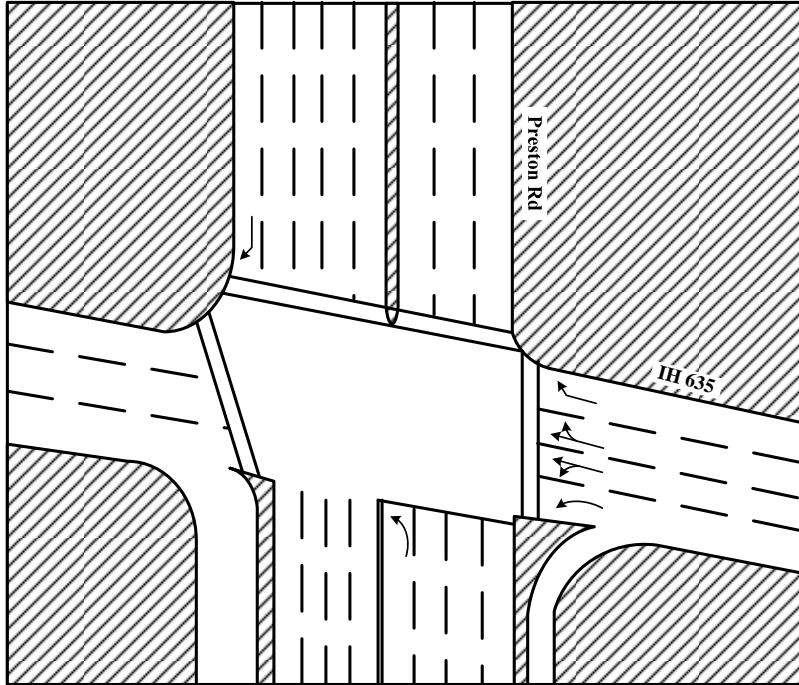
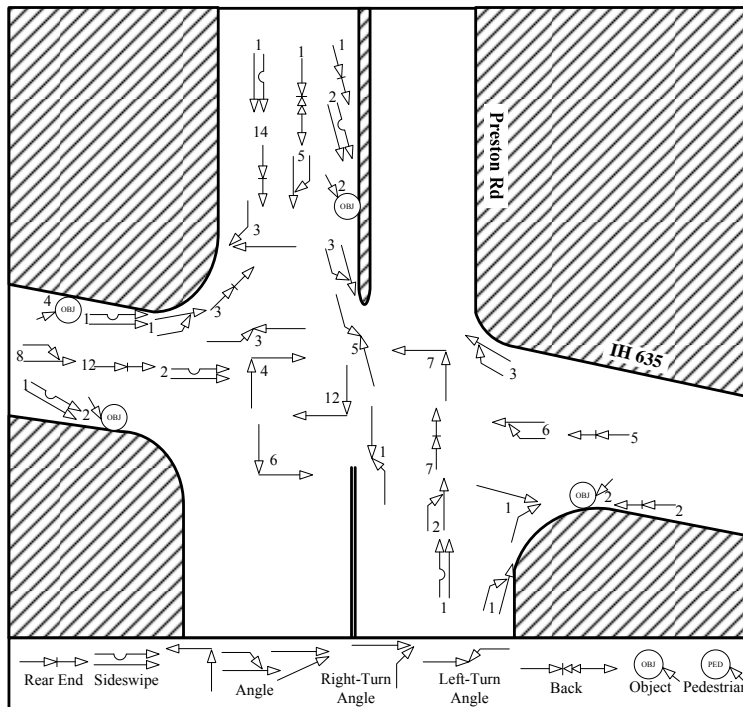


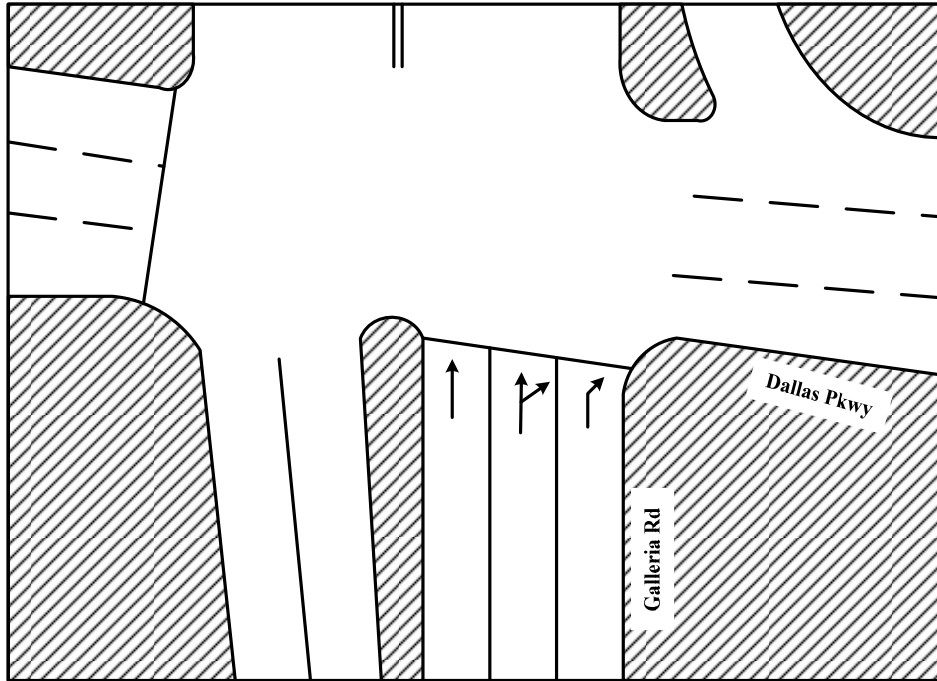
Figure A-8. Collision Diagram: Forest Lane at IH-635, Dallas.



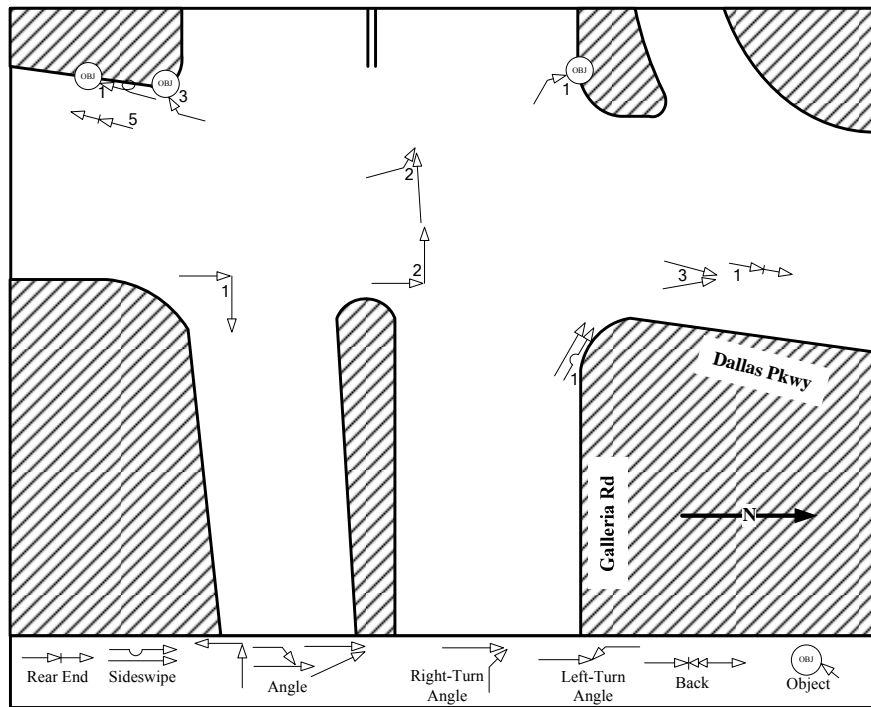
**Figure A-9. Intersection Layout: Preston Road at IH-635, Dallas.**



**Figure A-10. Collision Diagram: Preston Road at IH-635, Dallas.**



**Figure A-11. Intersection Layout: Galleria Road at Northbound Dallas North Tollway.**



**Figure A-12. Collision Diagram: Galleria Road at Northbound Dallas North Tollway.**

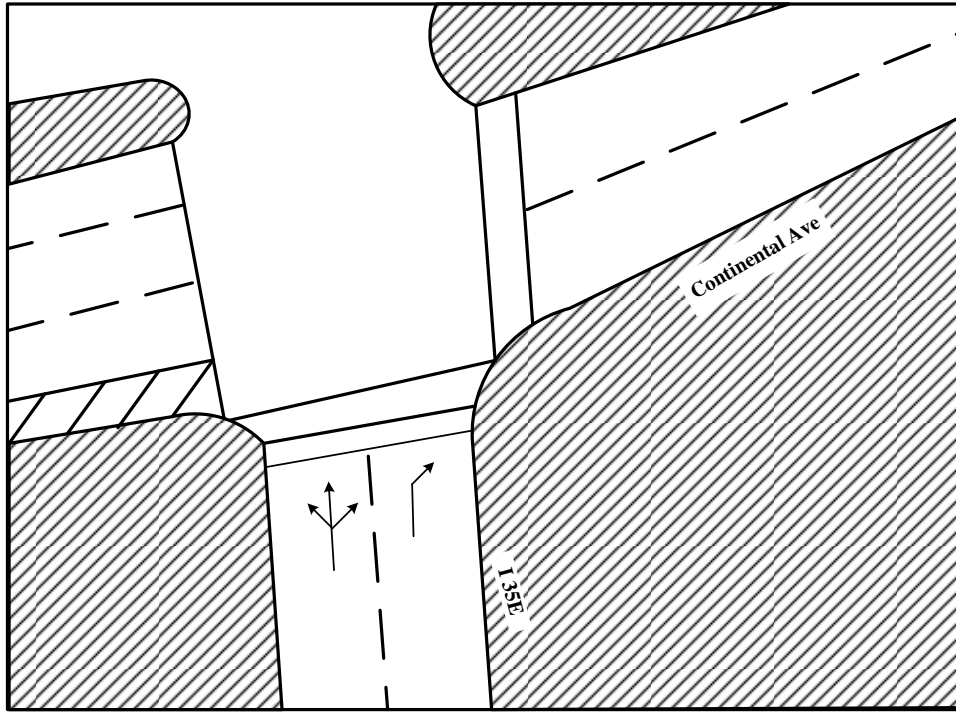


Figure A-13. Intersection Layout: Continental Avenue at IH-35E, Dallas.

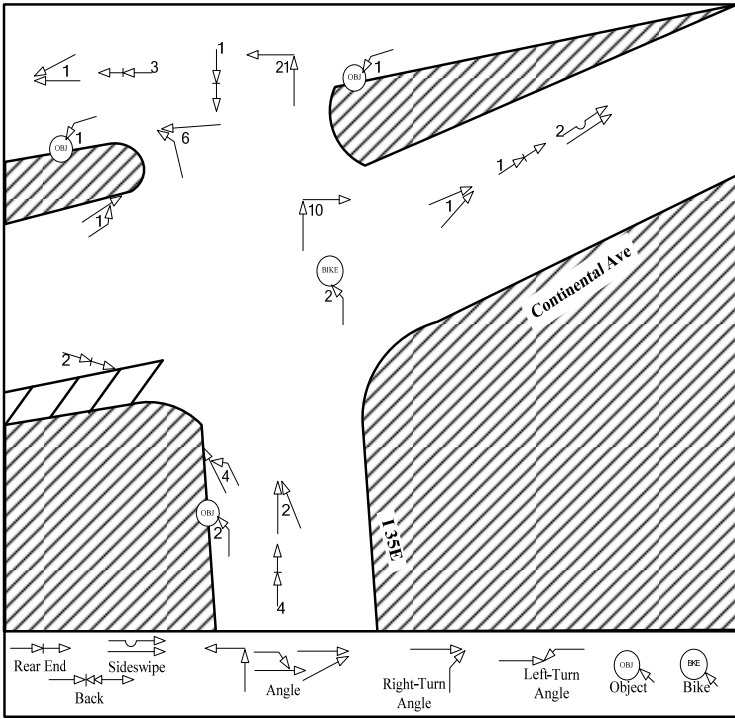
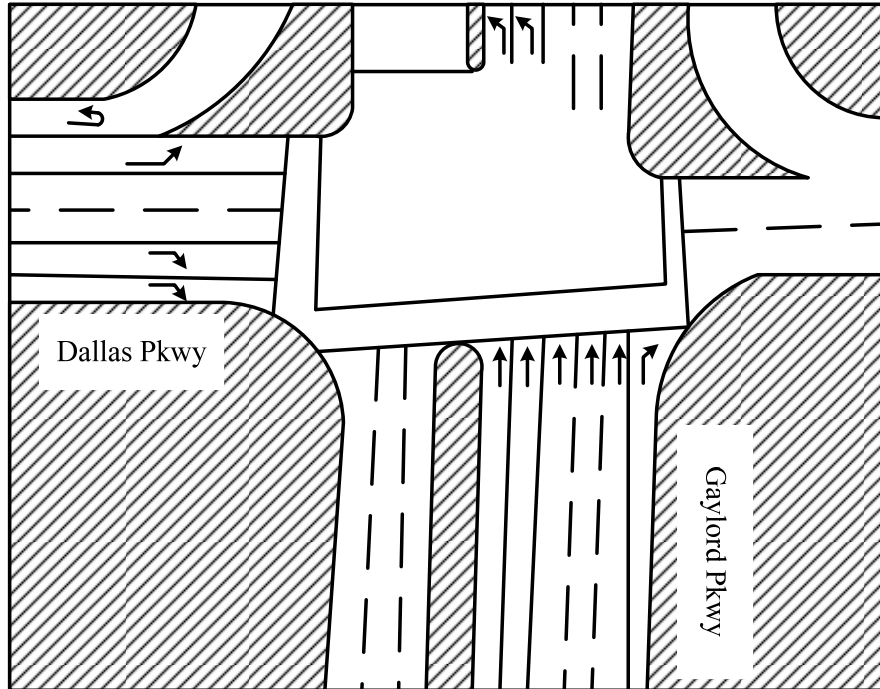
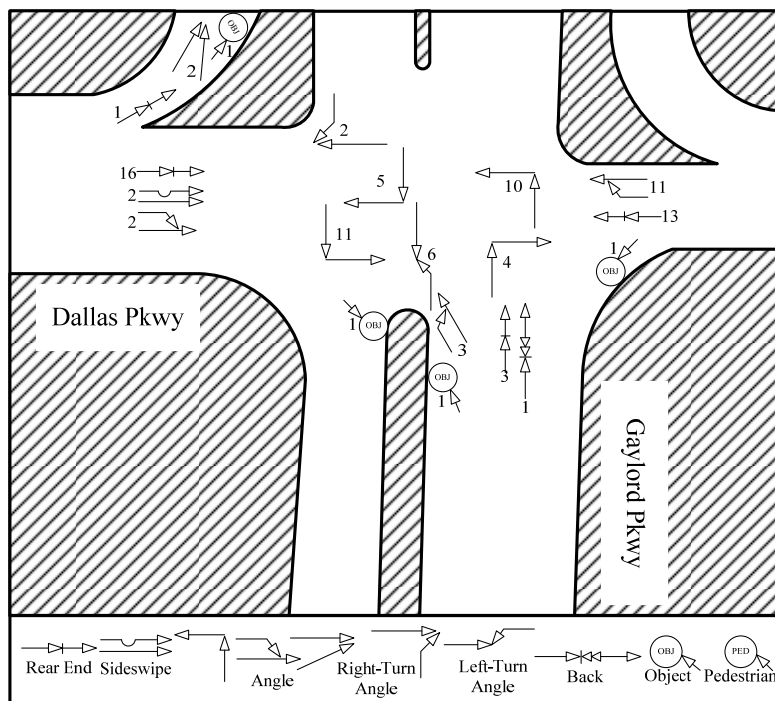


Figure A-14. Collision Diagram: Continental Avenue at IH-35E, Dallas.



**Figure A-15. Intersection Layout: Gaylord Parkway at NB Dallas North Tollway, Frisco.**



**Figure A-16. Collision Diagram: Gaylord Parkway at NB Dallas North Tollway, Frisco.**

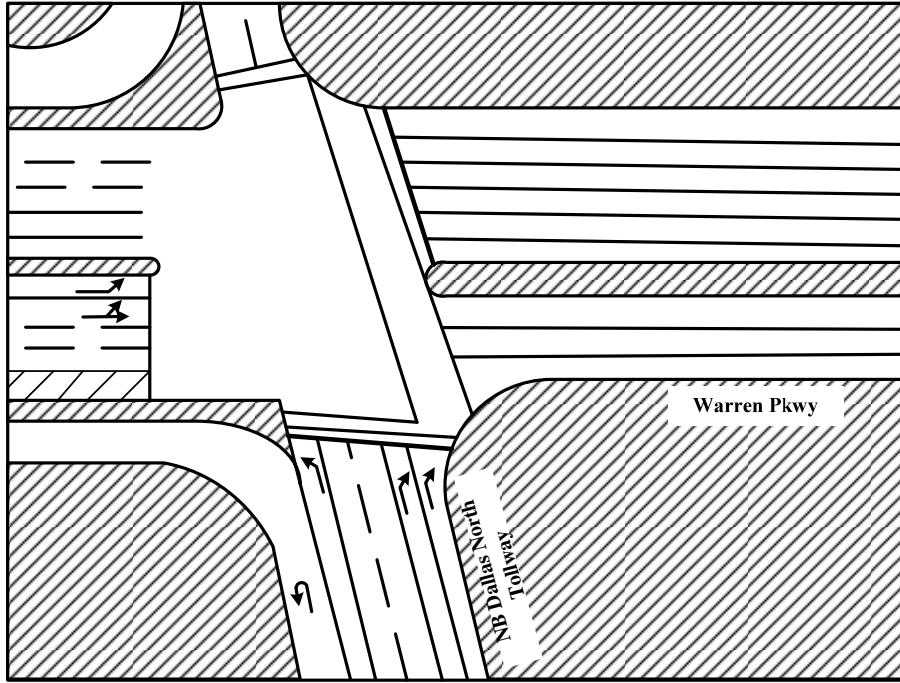


Figure A-17. Intersection Layout: Warren Parkway at NB Dallas North Tollway, Frisco.

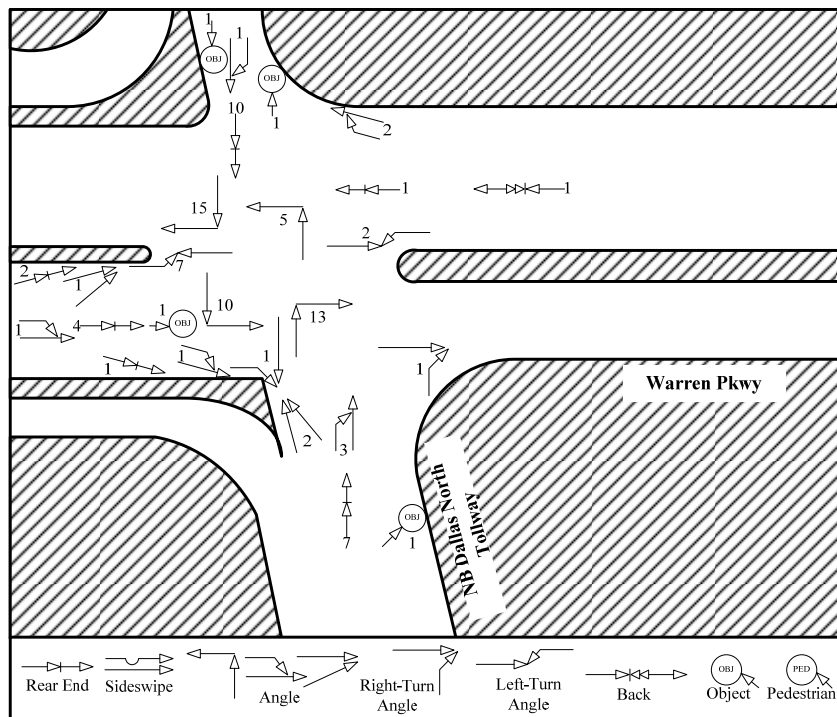
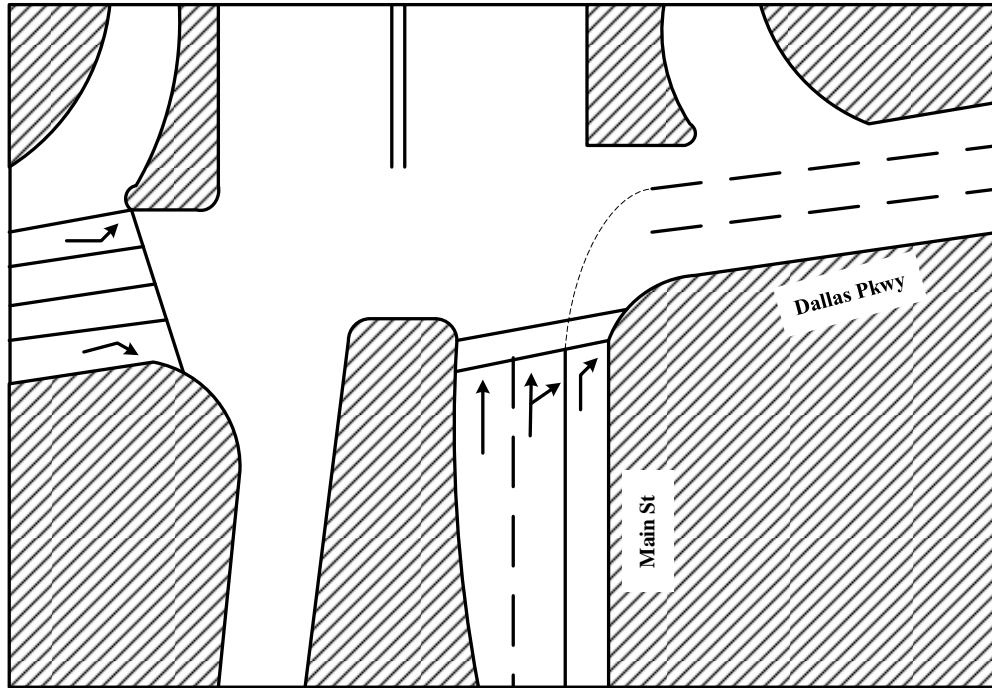
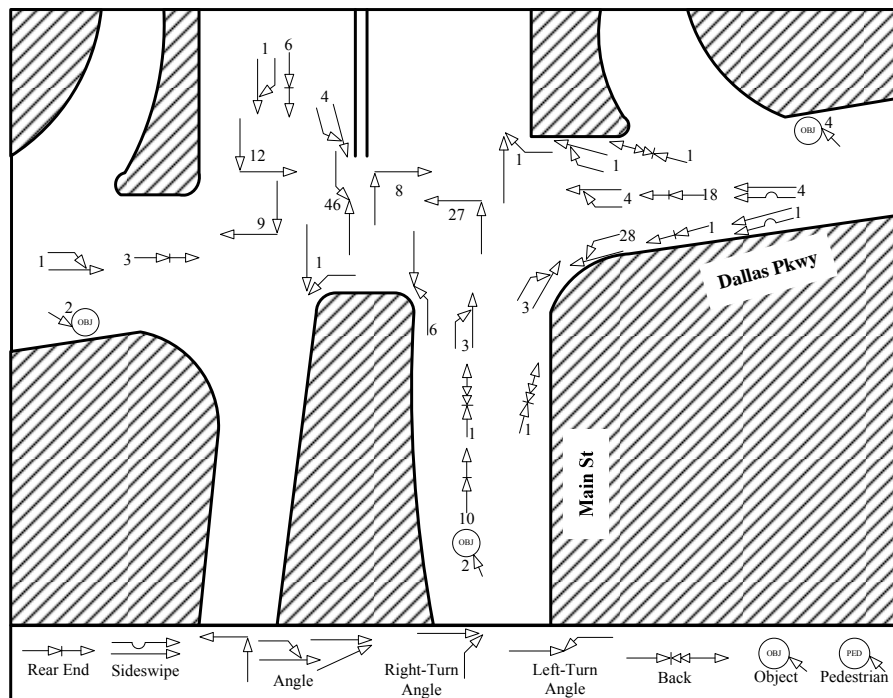


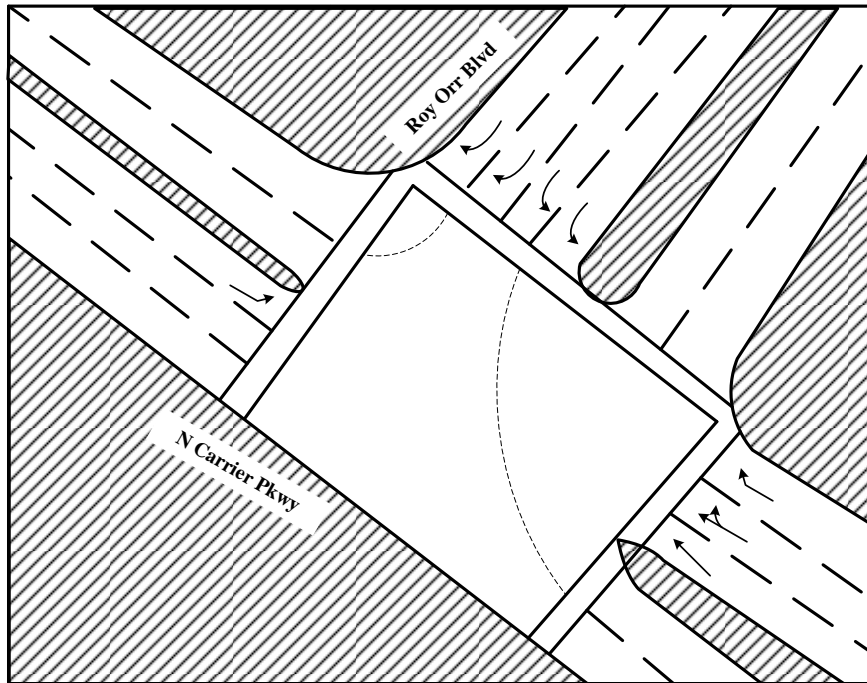
Figure A-18. Collision Diagram: Warren Parkway at NB Dallas North Tollway, Frisco.



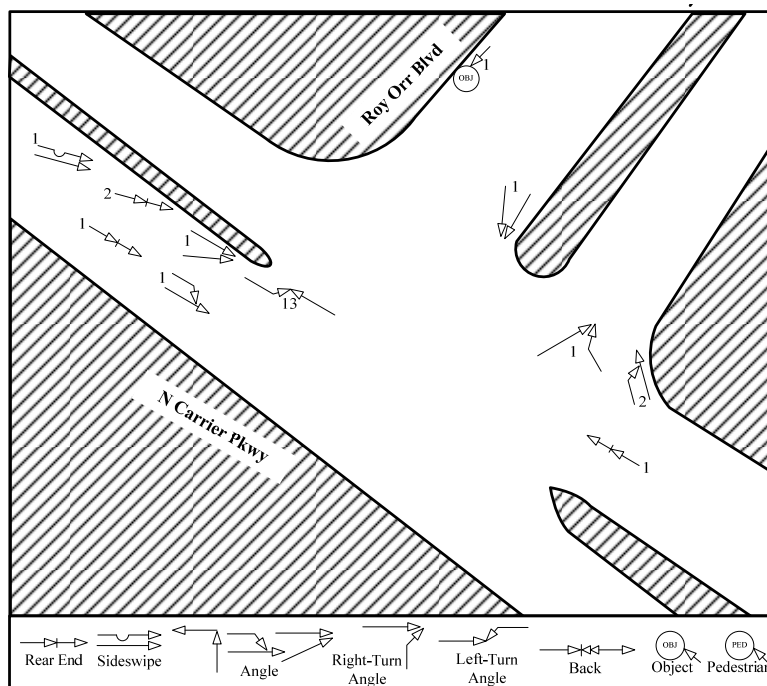
**Figure A-19. Intersection Layout: Main Street at SB Dallas North Tollway, Frisco.**



**Figure A-20. Collision Diagram: Main Street at SB Dallas North Tollway, Frisco.**

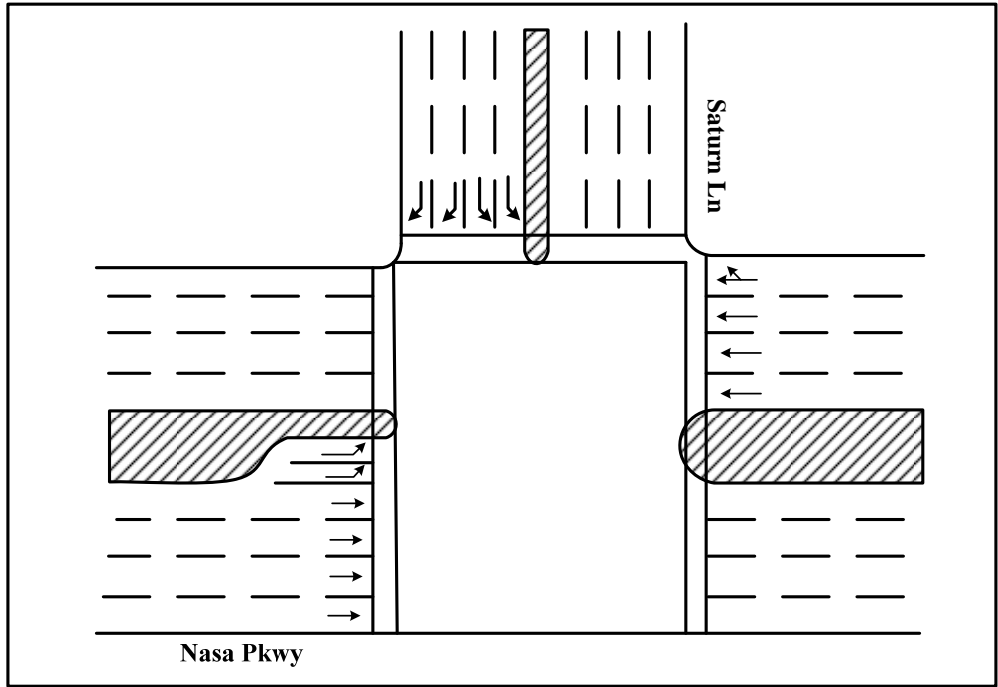


**Figure A-21. Intersection Layout: North Carrier Parkway at Roy Orr Boulevard, Grand Prairie.**

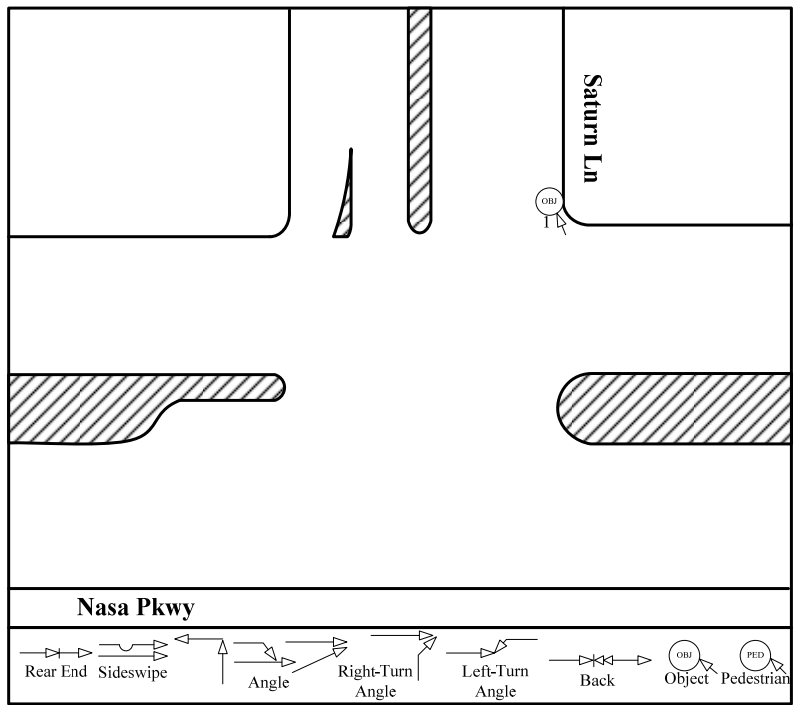


**Figure A-22. Collision Diagram: North Carrier Parkway at Roy Orr Boulevard, Grand Prairie.**





**Figure A-23. Intersection Layout: Saturn Lane at NASA Parkway, Houston.**



**Figure A-24. Collision Diagram: Saturn Lane at NASA Parkway, Houston.**

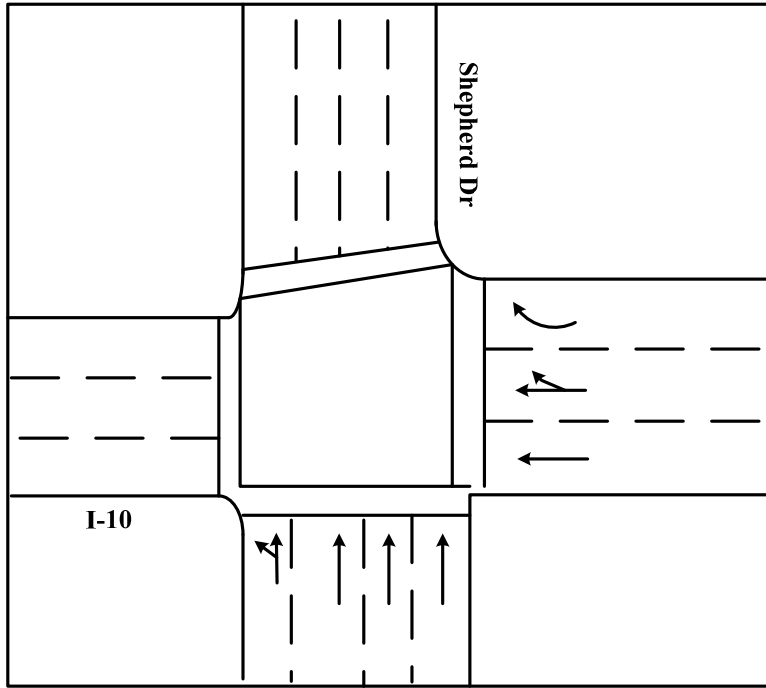


Figure A-25. Intersection Layout: Shepherd Drive at IH-10, Houston.

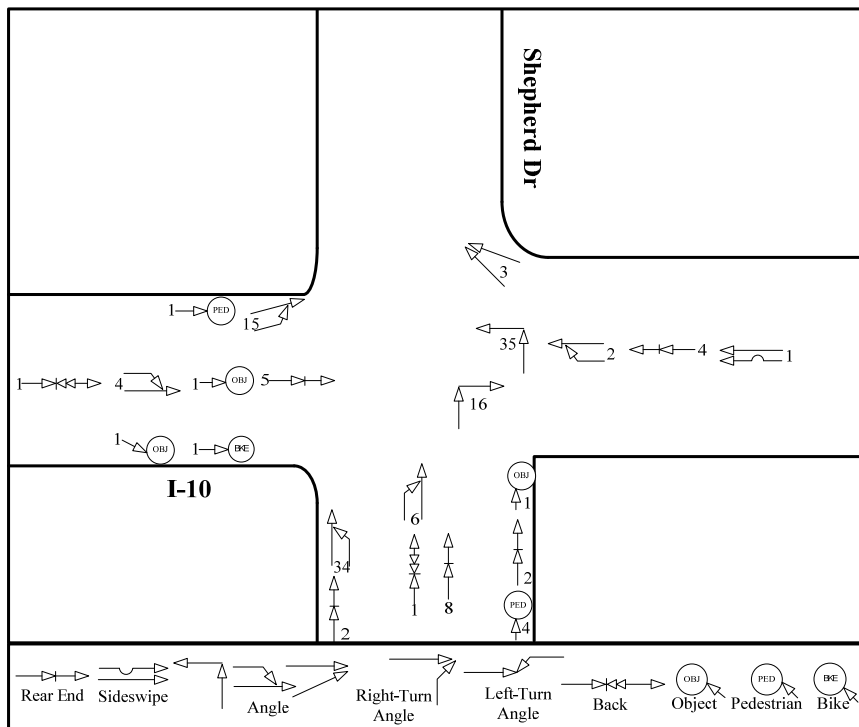


Figure A-26. Collision Diagram: Shepherd Drive at IH-10, Houston.

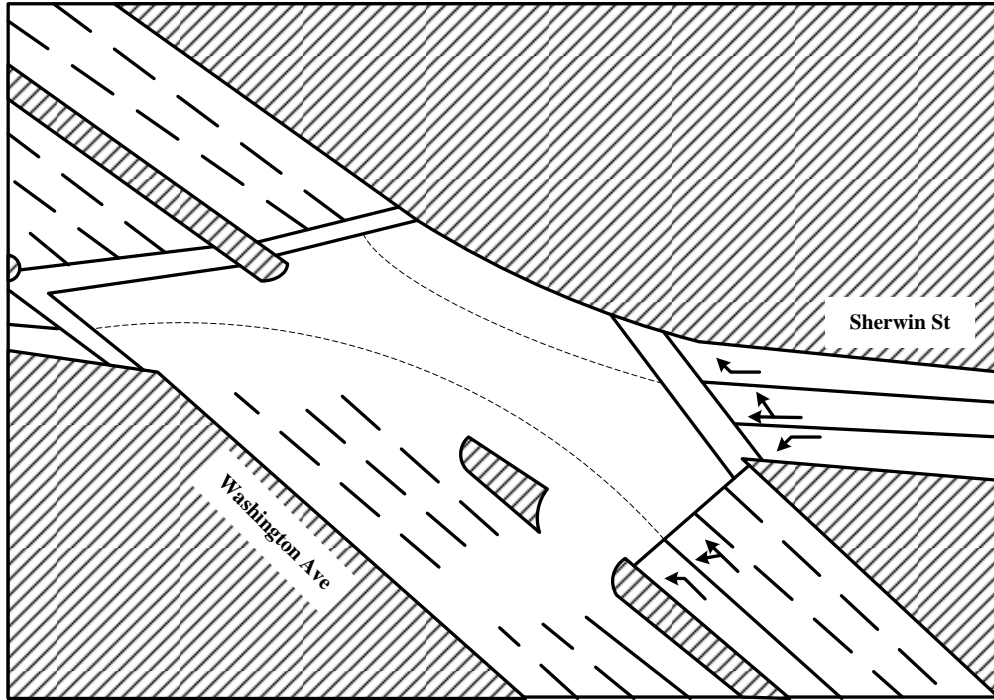


Figure A-27. Intersection Layout: Sherwin Street at Washington Avenue, Houston.

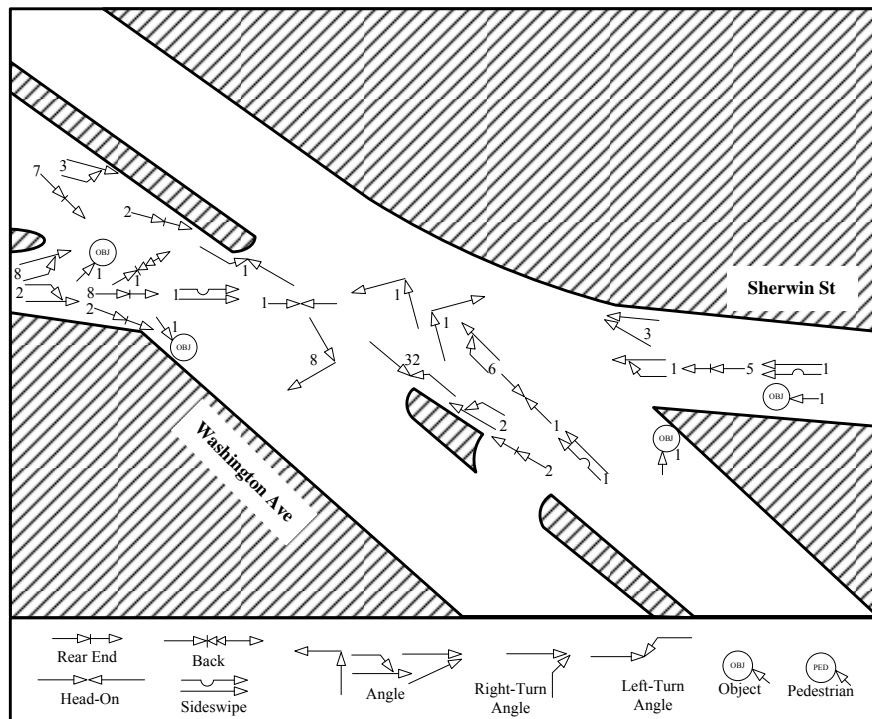


Figure A-28. Collision Diagram: Sherwin Street at Washington Avenue, Houston.

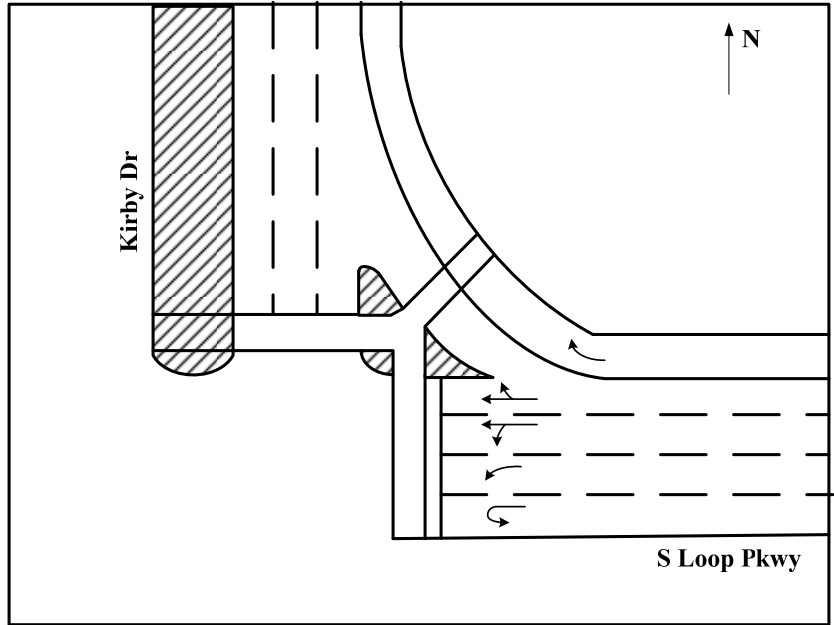


Figure A-29. Intersection Layout: Kirby Drive at IH-610 (S Loop Pkwy), Houston.

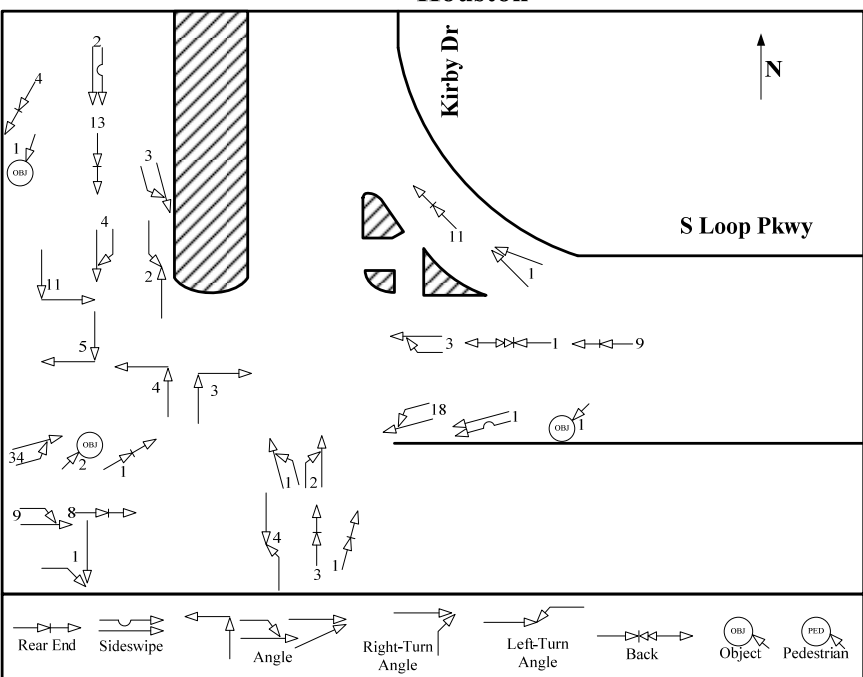


Figure A-30. Collision Diagram: Kirby Drive at IH-610 (S Loop Pkwy), Houston.

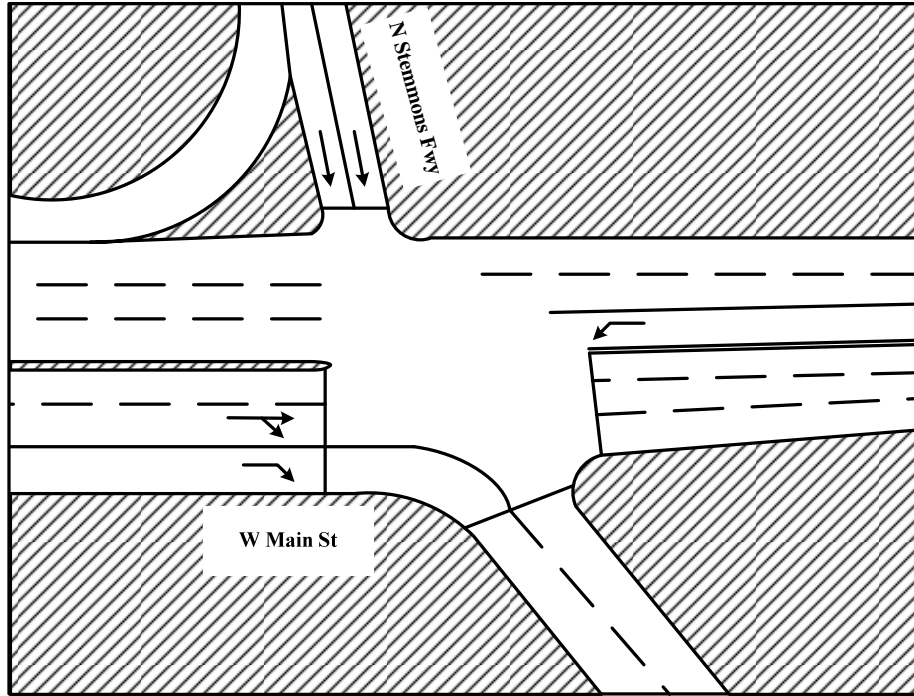


Figure A-31. Intersection Layout: Main Street at IH-35E, Lewisville.

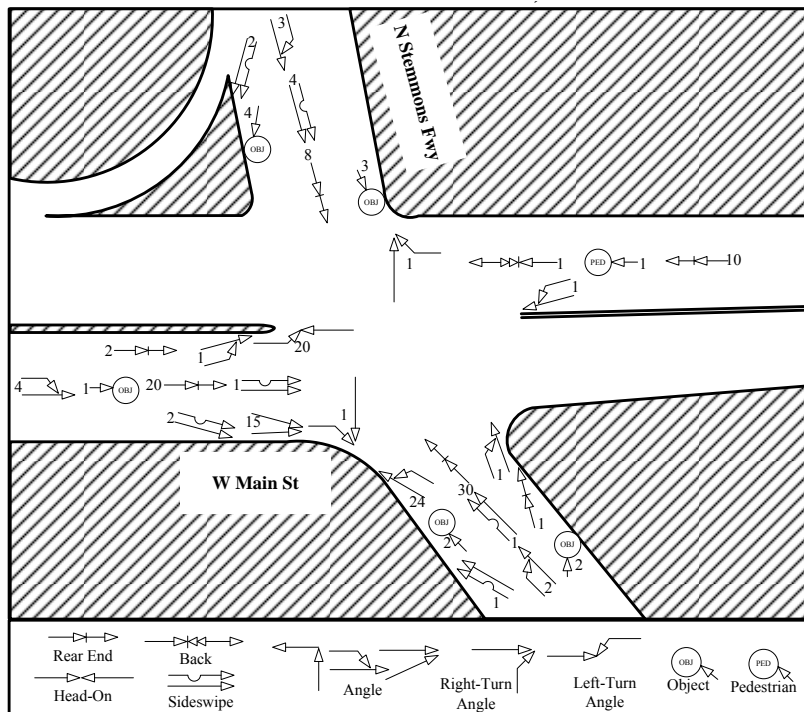


Figure A-32. Collision Diagram: Main Street at IH-35E, Lewisville.

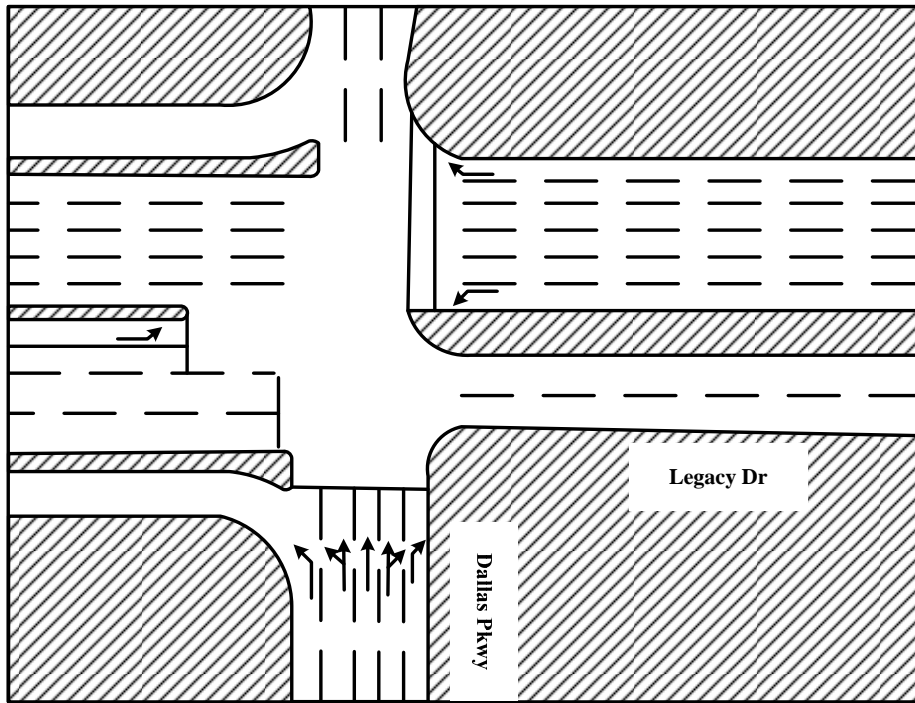


Figure A-33. Intersection Layout: Legacy Drive at NB Dallas North Tollway, Plano.

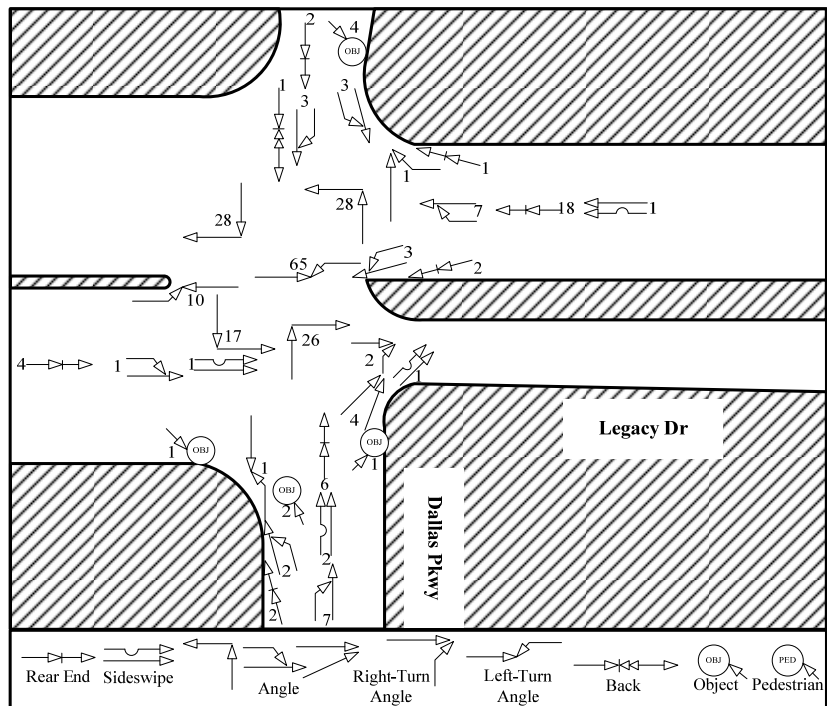
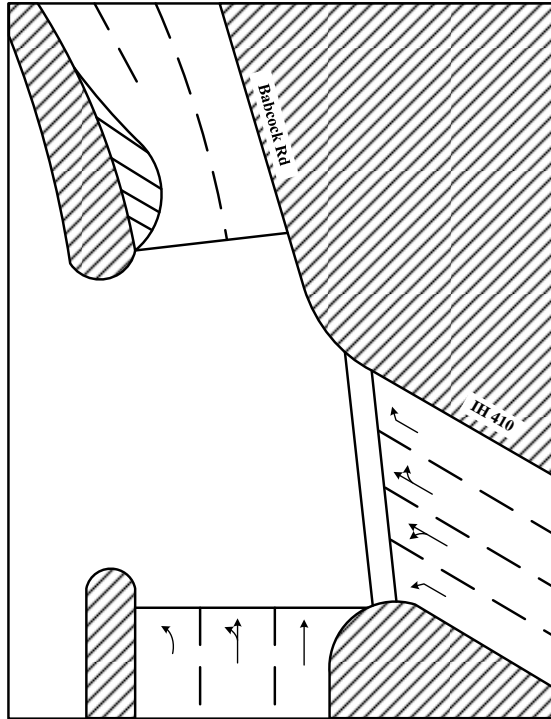
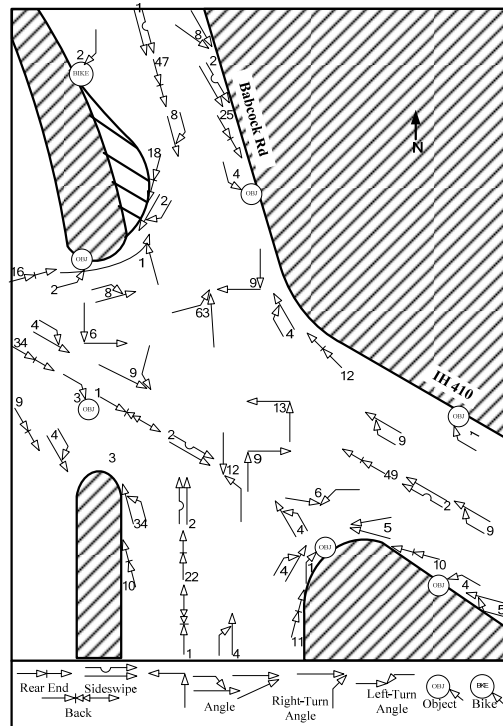


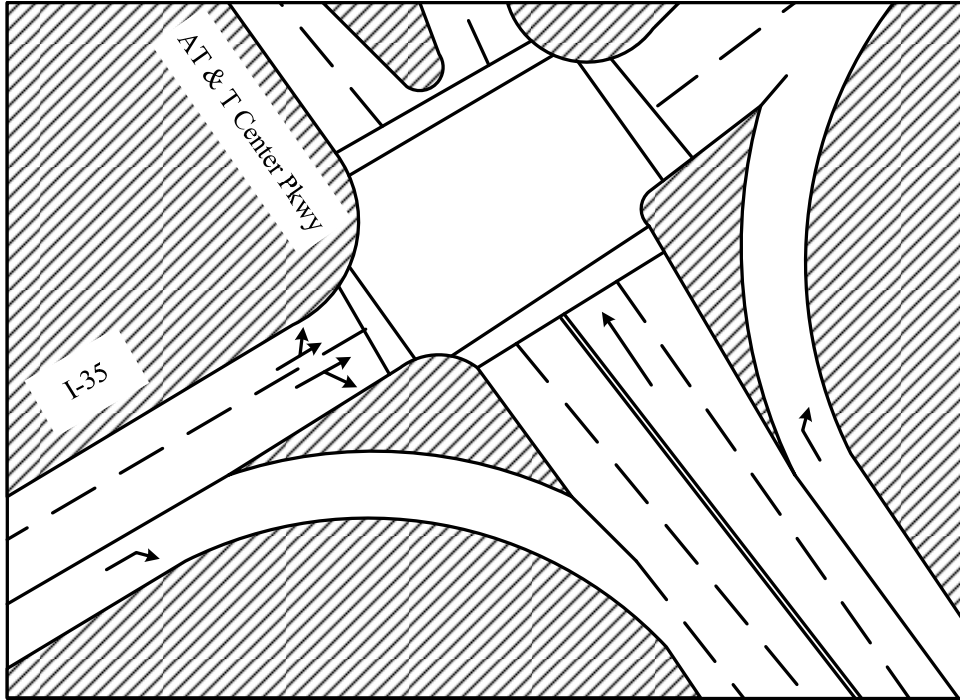
Figure A-34. Collision Diagram: Legacy Drive at NB Dallas North Tollway, Plano.



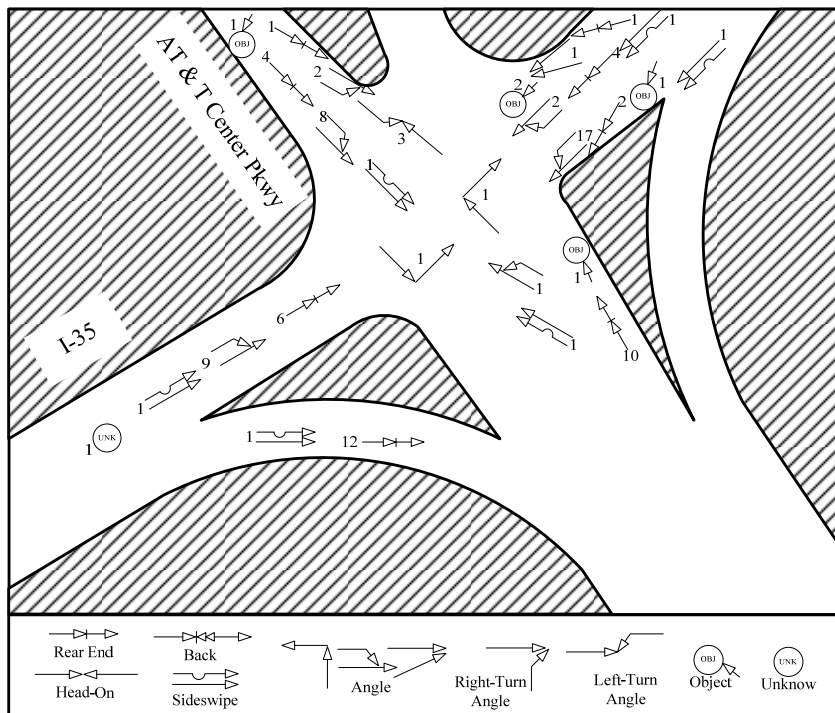
**Figure A-35. Intersection Layout: Babcock Road at WB IH-410, San Antonio.**



**Figure A-36. Collision Diagram: Babcock Road at WB IH-410, San Antonio.**

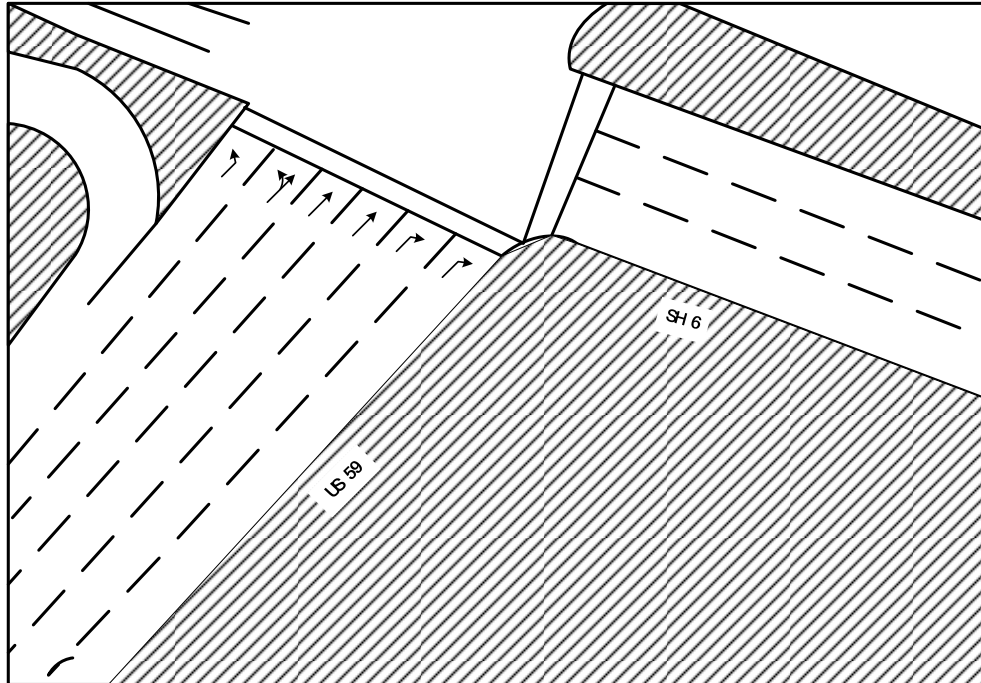


**Figure A-37. Intersection Layout: AT&T Center Parkway at IH-35, San Antonio.**

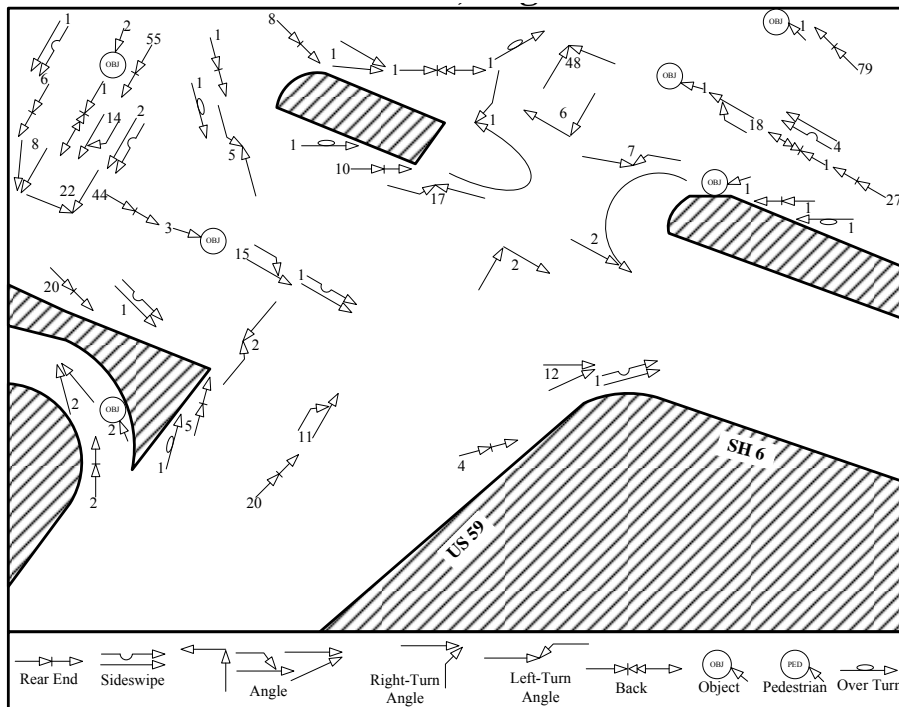


**Figure A-38. Collision Diagram: AT&T Center Parkway at IH-35, San Antonio.**





**Figure A-39. Intersection Layout: US 59 at SH 6, Sugar Land.**



**Figure A-40. Collision Diagram: US 59 at SH 6, Sugar Land.**

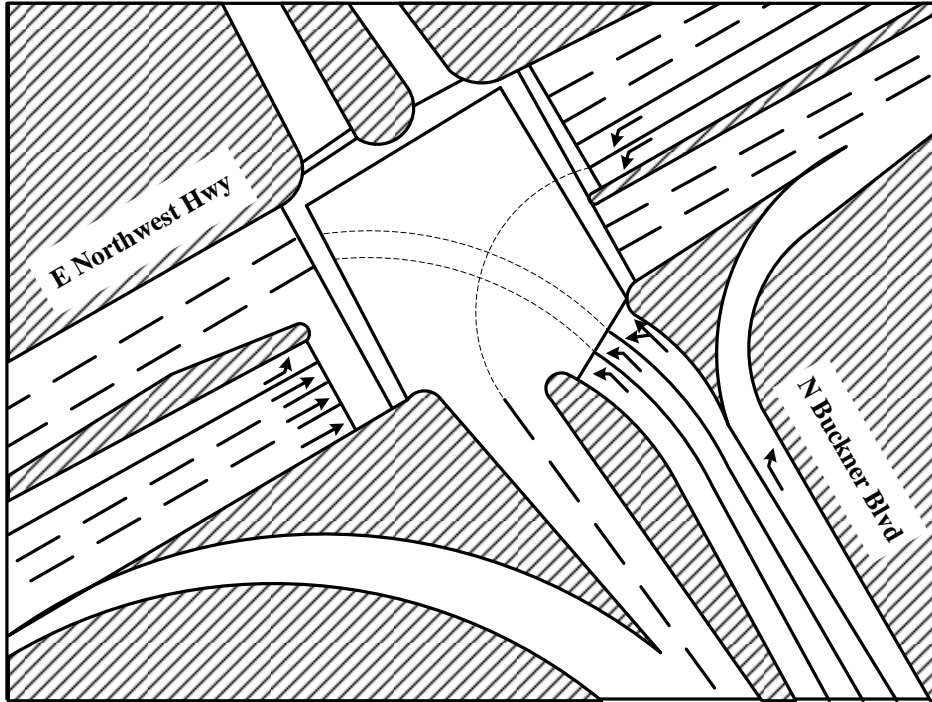


**APPENDIX B**

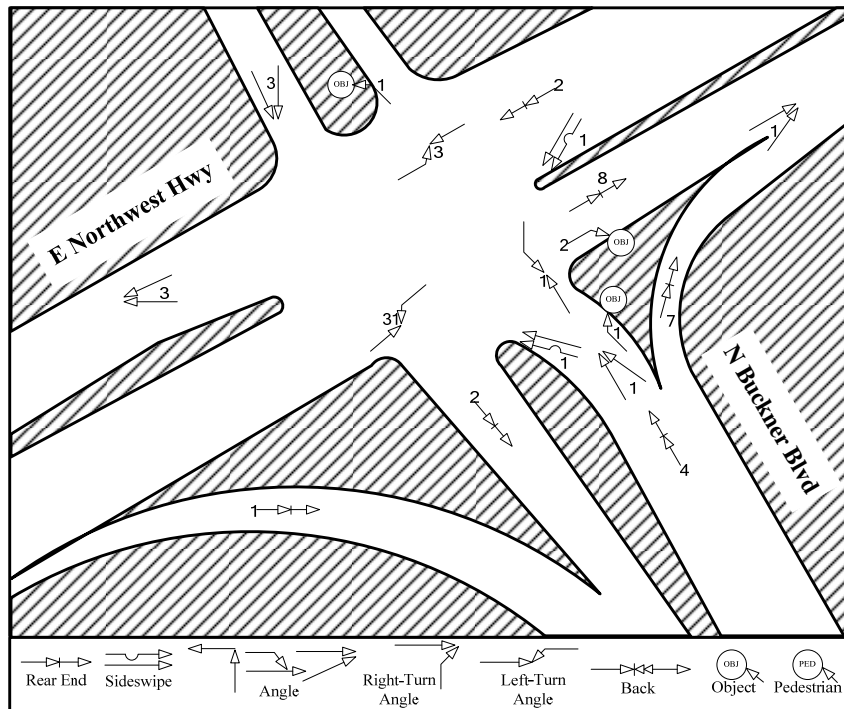
**COLLISION DIAGRAMS FOR  
TRIPLE LEFT-TURN LANES**



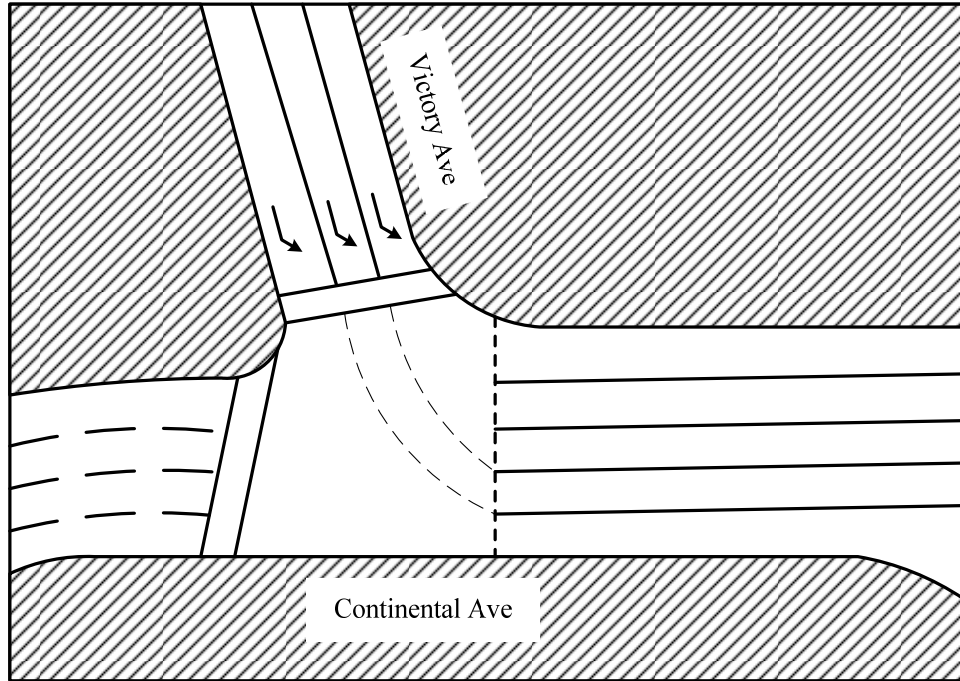
City	Intersection Name
Dallas	Northwest Highway at Bucker Boulevard
	Victory Avenue at Continental Avenue
	Griffin Street at Field Street
Houston	Westcott Street at Memorial Drive
Flower Mound	FM 2499 at Gerault Road



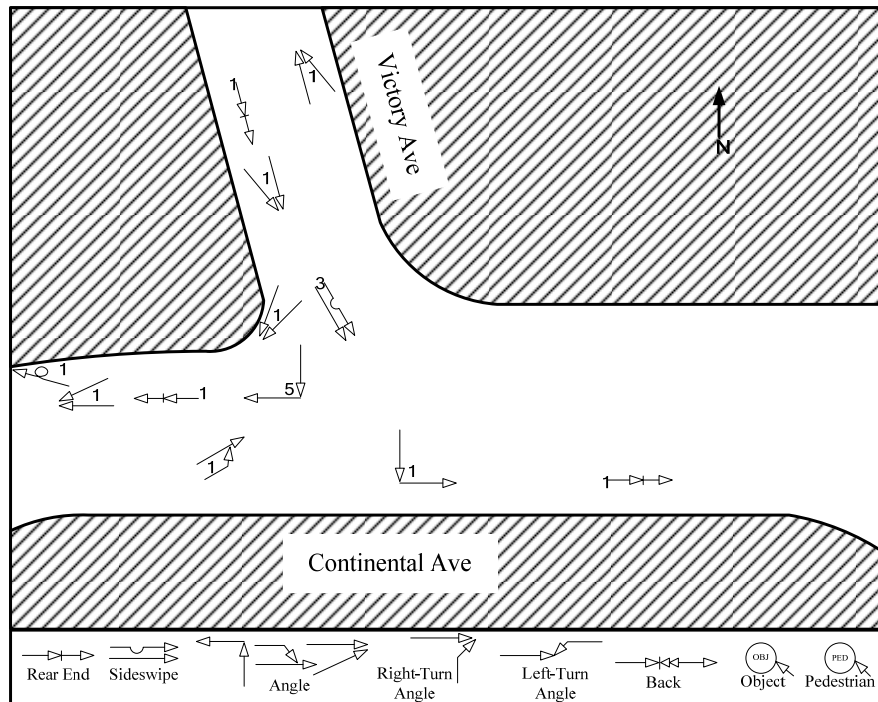
**Figure B-1. Intersection Layout: Northwest Highway at Buckner Boulevard, Dallas.**



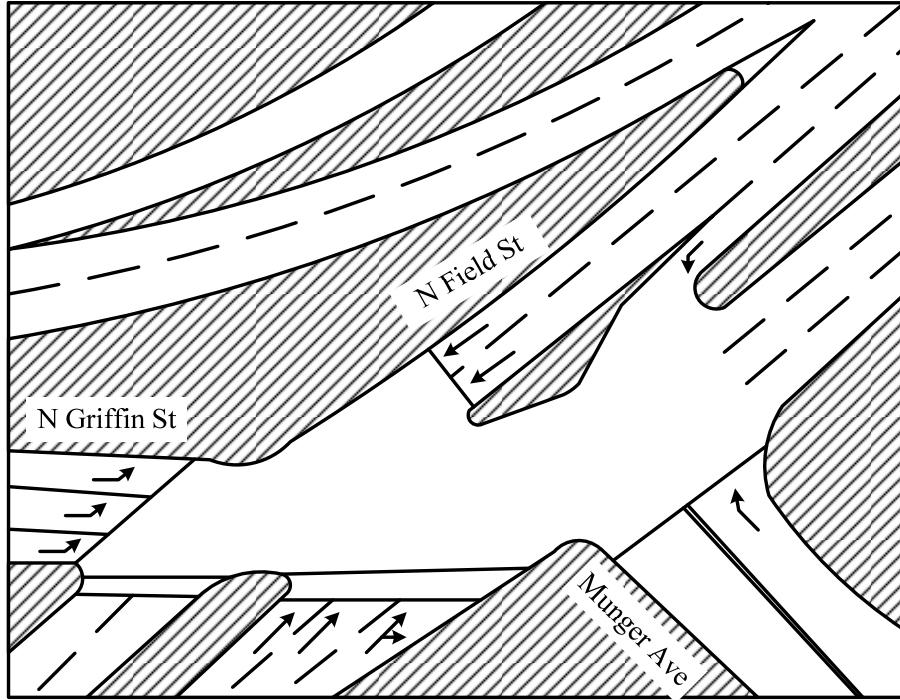
**Figure B-2. Collision Diagram: Northwest Highway at Buckner Boulevard, Dallas.**



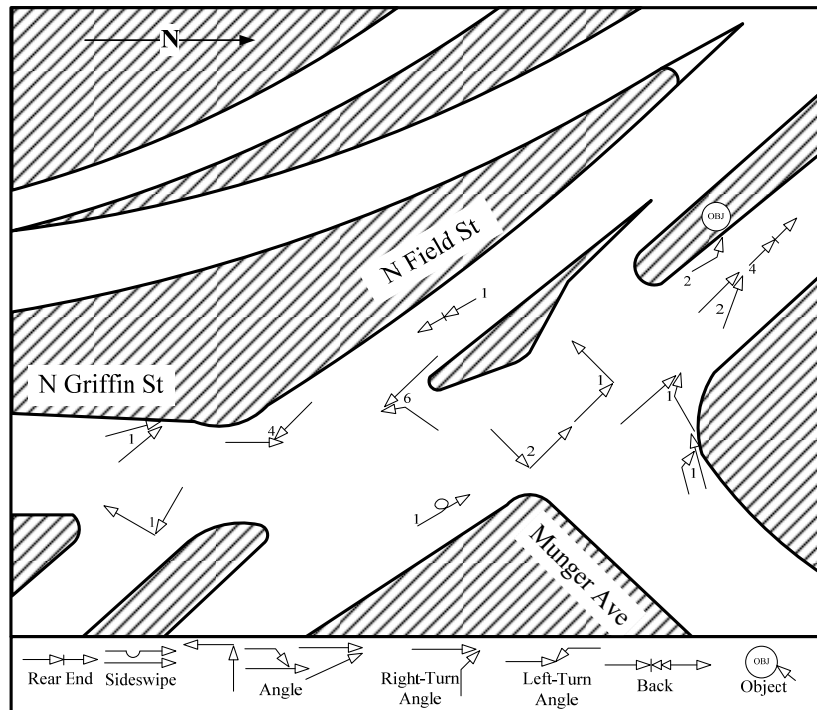
**Figure B-3. Intersection Layout: Victory Avenue at Continental Avenue, Dallas.**



**Figure B-4. Collision Diagram: Victory Avenue at Continental Avenue, Dallas.**



**Figure B-5. Intersection Layout: Griffin Street at Field Street, Dallas.**



**Figure B-6. Collision Diagram: Griffin Street at Field Street, Dallas.**



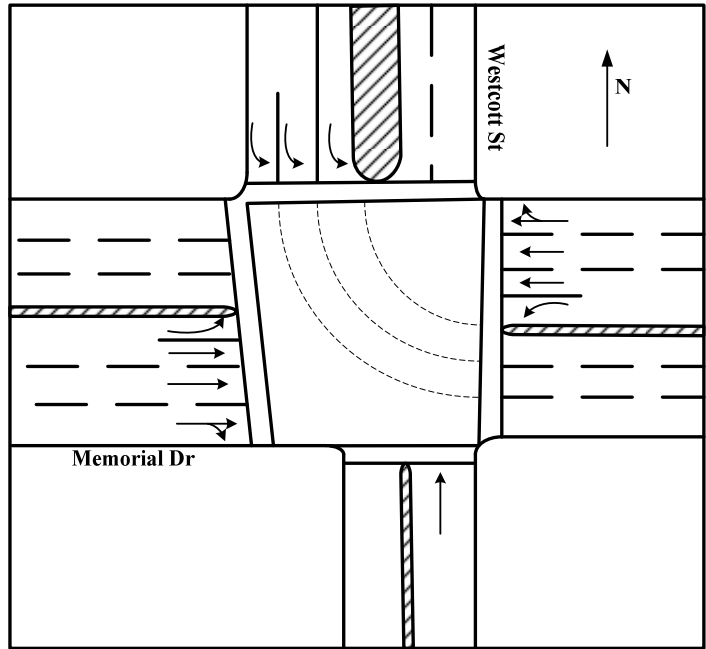


Figure B-7. Intersection Layout: Westcott Street at Memorial Drive, Houston.

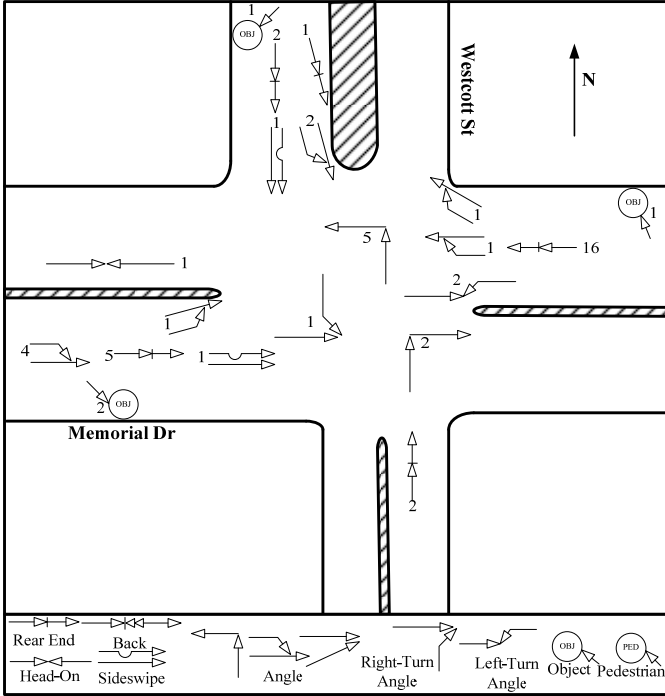


Figure B-8. Collision Diagram: Westcott Street at Memorial Drive, Houston.

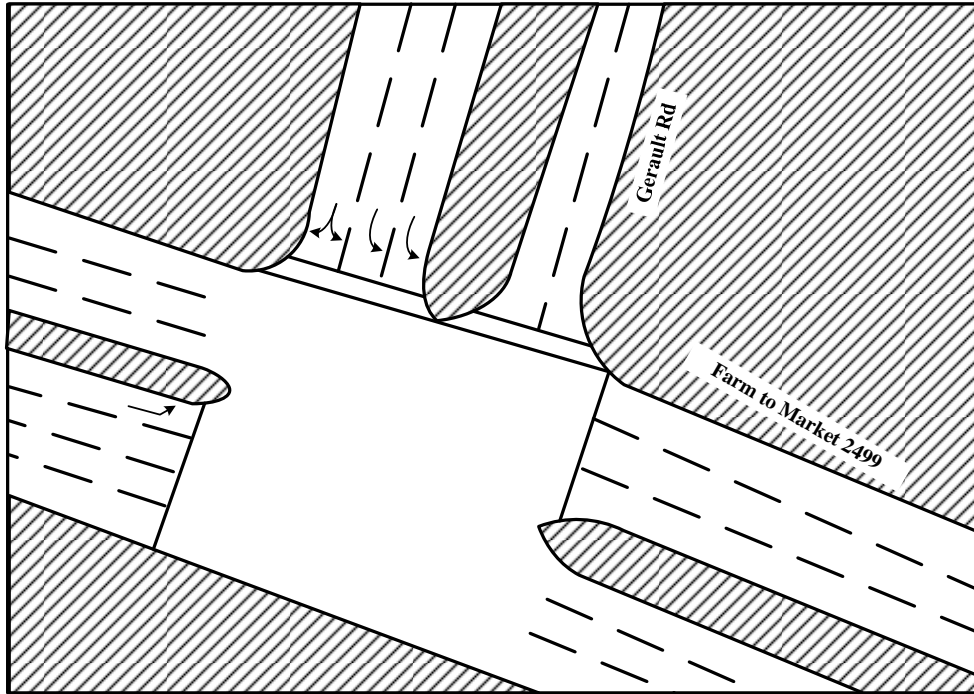


Figure B-9. Intersection Layout: FM 2499 at Gerault Road, Flower Mound.

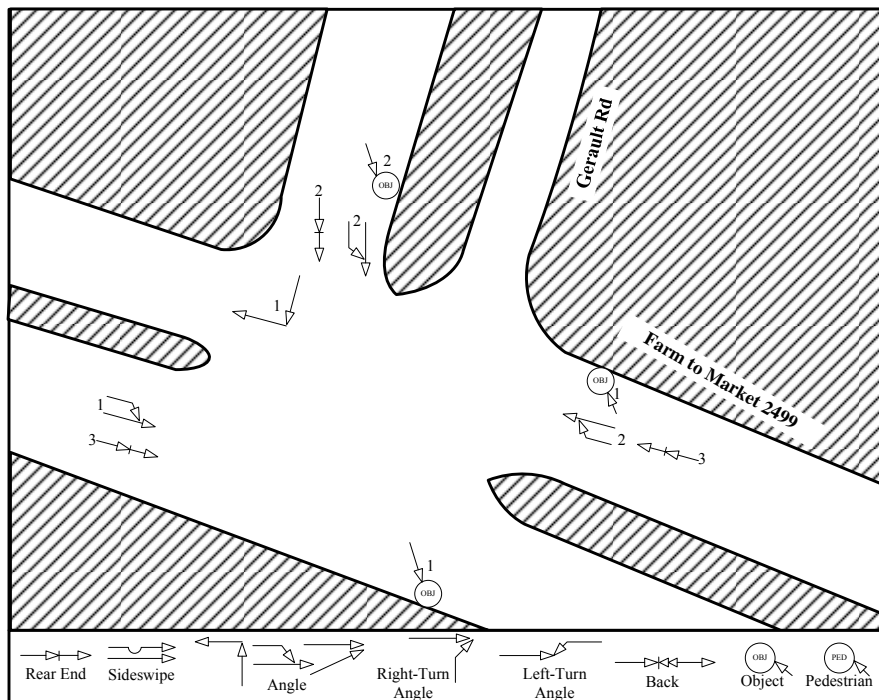


Figure B-10. Collision Diagram: FM 2499 at Gerault Road, Flower Mound.

**APPENDIX C**

**TEXAS TRANSPORTATION CODE 544.007C**



TRANSPORTATION CODE

TITLE 7. VEHICLES AND TRAFFIC

SUBTITLE C. RULES OF THE ROAD

CHAPTER 544. TRAFFIC SIGNS, SIGNALS, AND MARKINGS

Sec. 544.001. ADOPTION OF SIGN MANUAL FOR STATE HIGHWAYS. The Texas Transportation Commission shall adopt a manual and specifications for a uniform system of traffic-control devices consistent with this chapter that correlates with and to the extent possible conforms to the system approved by the American Association of State Highway and Transportation Officials.

Acts 1995, 74th Leg., ch. 165, Sec. 1, eff. Sept. 1, 1995.

Sec. 544.002. PLACING AND MAINTAINING TRAFFIC-CONTROL DEVICE. (a) To implement this subtitle, the Texas Department of Transportation may place and maintain a traffic-control device on a state highway as provided by the manual and specifications adopted under Section 544.001. The Texas Department of Transportation may provide for the placement and maintenance of the device under Section 221.002.

(b) To implement this subtitle or a local traffic ordinance, a local authority may place and maintain a traffic-control device on a highway under the authority's jurisdiction. The traffic-control device must conform to the manual and specifications adopted under Section 544.001.

(c) A local authority may not place or maintain a traffic-control device on a highway under the jurisdiction of the Texas Department of Transportation without that department's permission.

Acts 1995, 74th Leg., ch. 165, Sec. 1, eff. Sept. 1, 1995.

Sec. 544.003. AUTHORITY TO DESIGNATE THROUGH HIGHWAY AND STOP AND YIELD INTERSECTIONS. (a) The Texas Transportation Commission may:

(1) designate a state or county highway as a through highway and place a stop or yield sign at a specified entrance; or

(2) designate an intersection on a state or county highway as a stop intersection or a yield intersection and place a sign at one or more entrances to the intersection.

(b) A local authority may:

(1) designate a highway under its jurisdiction as a through highway and place a stop or yield sign at a specified entrance; or

(2) designate an intersection on a highway under its jurisdiction as a stop intersection or a yield intersection and place a sign at one or more entrances to the intersection.

(c) The stop or yield sign indicating the preferential right-of-way must:

(1) conform to the manual and specifications adopted under Section 544.001; and

(2) be located:

(A) as near as practicable to the nearest line of the crosswalk; or

(B) in the absence of a crosswalk, at the nearest line of the roadway.

Acts 1995, 74th Leg., ch. 165, Sec. 1, eff. Sept. 1, 1995.

Sec. 544.004. COMPLIANCE WITH TRAFFIC-CONTROL DEVICE.

(a) The operator of a vehicle or streetcar shall comply with an applicable official traffic-control device placed as provided by this subtitle unless the person is:

(1) otherwise directed by a traffic or police officer; or

(2) operating an authorized emergency vehicle and is subject to exceptions under this subtitle.

(b) A provision of this subtitle requiring an official traffic-control device may not be enforced against an alleged violator if at the time and place of the alleged violation the device is not in proper position and sufficiently legible to an ordinarily observant person. A provision of this subtitle that does not require an official traffic-control device is effective regardless of whether a device is in place.

Acts 1995, 74th Leg., ch. 165, Sec. 1, eff. Sept. 1, 1995.

Sec. 544.005. INTERFERENCE WITH TRAFFIC-CONTROL DEVICE OR RAILROAD SIGN OR SIGNAL. A person may not, without lawful authority, alter, injure, knock down, or remove or attempt to alter, injure, knock down, or remove:

(1) an official traffic-control device or railroad sign or signal;

(2) an inscription, shield, or insignia on an official traffic-control device or railroad sign or signal; or

(3) another part of an official traffic-control device or railroad sign or signal.

Acts 1995, 74th Leg., ch. 165, Sec. 1, eff. Sept. 1, 1995.

Sec. 544.0055. TRAFFIC-CONTROL SIGNAL PREEMPTION DEVICE; OFFENSE. (a) In this section, "traffic-control signal preemption device" means a device designed, intended, or used to interfere with or alter the operation of a traffic-control signal.

(b) Except as provided by Subsection (e), a person commits an offense if the person uses, sells, offers for sale, purchases, or possesses for use or sale a traffic-control signal preemption device.

(c) The possession of a traffic-control signal preemption device creates the presumption that the person possessed the

device for use or sale.

(d) An offense under this section is a Class C misdemeanor.

(e) This section does not apply to:

(1) a person who provides fire-fighting, law enforcement, ambulance, medical, or other emergency services in the course of providing those services;

(2) a manufacturer, wholesaler, or retailer of traffic-control signal preemption devices in the course of manufacturing, selling, providing, or transporting a traffic-control signal preemption device to a person described by Subdivision (1); or

(3) a transit vehicle operated by an authority under Chapter 451 or 452 or a transit department under Chapter 453.

Added by Acts 2005, 79th Leg., Ch. [244](#), Sec. 1, eff. May 30, 2005.

Sec. 544.006. DISPLAY OF UNAUTHORIZED SIGNS, SIGNALS, OR MARKINGS. (a) A person may not place, maintain, or display on or in view of a highway an unauthorized sign, signal, marking, or device that:

(1) imitates or resembles an official traffic-control device or railroad sign or signal;

(2) attempts to direct the movement of traffic; or

(3) hides from view or hinders the effectiveness of an official traffic-control device or railroad sign or signal.

(b) A person may not place or maintain on a highway, and a public authority may not permit on a highway, a traffic sign or signal bearing commercial advertising.

(c) A person may not place or maintain a flashing light or flashing electric sign within 1,000 feet of an intersection except under a permit issued by the Texas Transportation Commission.

(d) This section does not prohibit a person from placing on private property adjacent to a highway a sign that gives



useful directional information and that cannot be mistaken for an official sign.

(e) A sign, signal, light, or marking prohibited under this section is a public nuisance. The authority with jurisdiction over the highway may remove that sign, signal, light, or marking without notice.

Acts 1995, 74th Leg., ch. 165, Sec. 1, eff. Sept. 1, 1995.

Sec. 544.007. TRAFFIC-CONTROL SIGNALS IN GENERAL. (a) A traffic-control signal displaying different colored lights or colored lighted arrows successively or in combination may display only green, yellow, or red and applies to operators of vehicles as provided by this section.

(b) An operator of a vehicle facing a circular green signal may proceed straight or turn right or left unless a sign prohibits the turn. The operator shall yield the right-of-way to other vehicles and to pedestrians lawfully in the intersection or an adjacent crosswalk when the signal is exhibited.

(c) An operator of a vehicle facing a green arrow signal, displayed alone or with another signal, may cautiously enter the intersection to move in the direction permitted by the arrow or other indication shown simultaneously. The operator shall yield the right-of-way to a pedestrian lawfully in an adjacent crosswalk and other traffic lawfully using the intersection.

(d) An operator of a vehicle facing only a steady red signal shall stop at a clearly marked stop line. In the absence of a stop line, the operator shall stop before entering the crosswalk on the near side of the intersection. A vehicle that is not turning shall remain standing until an indication to proceed is shown. After stopping, standing until the intersection may be entered safely, and yielding right-of-way to pedestrians lawfully in an adjacent crosswalk and other traffic lawfully using the intersection, the operator may:

- (1) turn right; or

(2) turn left, if the intersecting streets are both one-way streets and a left turn is permissible.

(e) An operator of a vehicle facing a steady yellow signal is warned by that signal that:

(1) movement authorized by a green signal is being terminated; or

(2) a red signal is to be given.

(f) The Texas Transportation Commission, a municipal authority, or the commissioners court of a county may prohibit within the entity's jurisdiction a turn by an operator of a vehicle facing a steady red signal by posting notice at the intersection that the turn is prohibited.

(g) This section applies to an official traffic-control signal placed and maintained at a place other than an intersection, except for a provision that by its nature cannot apply. A required stop shall be made at a sign or marking on the pavement indicating where the stop shall be made. In the absence of such a sign or marking, the stop shall be made at the signal.

(h) The obligations imposed by this section apply to an operator of a streetcar in the same manner they apply to the operator of a vehicle.

(i) An operator of a vehicle facing a traffic-control signal that does not display an indication in any of the signal heads shall stop as provided by Section 544.010 as if the intersection had a stop sign.

Acts 1995, 74th Leg., ch. 165, Sec. 1, eff. Sept. 1, 1995.  
Amended by Acts 2003, 78th Leg., ch. 1325, Sec. 19.04, eff.  
Sept. 1, 2003.

Sec. 544.0075. CERTAIN TRAFFIC-ACTUATED ELECTRIC TRAFFIC-CONTROL SIGNALS. (a) This section applies only to a traffic-actuated electric traffic-control signal that consists of a traffic-control signal for which the intervals vary according to the demands of vehicular traffic as registered by a detector and

that is installed and operating at an intersection.

(b) In addition to any other type of vehicle the presence of which the detector for the traffic-actuated electric traffic-control signal may register, the detector for a traffic-actuated electric traffic-control device to which this section applies must be capable of registering the presence of a motorcycle.

Added by Acts 2007, 80th Leg., R.S., Ch. [219](#), Sec. 1, eff. September 1, 2007.

Sec. 544.008. FLASHING SIGNALS. (a) The operator of a vehicle facing a flashing red signal shall stop at a clearly marked stop line. In the absence of a stop line, the operator shall stop before entering the crosswalk on the near side of the intersection. In the absence of a crosswalk, the operator shall stop at the place nearest the intersecting roadway where the operator has a view of approaching traffic on the intersecting roadway. The right to proceed is subject to the rules applicable after stopping at a stop sign.

(b) The operator of a vehicle facing a flashing yellow signal may proceed through an intersection or past the signal only with caution.

(c) This section does not apply at a railroad crossing.

Acts 1995, 74th Leg., ch. 165, Sec. 1, eff. Sept. 1, 1995.

Sec. 544.009. LANE-DIRECTION-CONTROL SIGNALS. If a lane-direction-control signal is placed over an individual lane of a highway, a vehicle may travel in a lane over which a green signal is shown but may not enter or travel in a lane over which a red signal is shown.

Acts 1995, 74th Leg., ch. 165, Sec. 1, eff. Sept. 1, 1995.

Sec. 544.010. STOP SIGNS AND YIELD SIGNS. (a) Unless directed to proceed by a police officer or traffic-control

signal, the operator of a vehicle or streetcar approaching an intersection with a stop sign shall stop as provided by Subsection (c).

(b) If safety requires, the operator of a vehicle approaching a yield sign shall stop as provided by Subsection (c).

(c) An operator required to stop by this section shall stop before entering the crosswalk on the near side of the intersection. In the absence of a crosswalk, the operator shall stop at a clearly marked stop line. In the absence of a stop line, the operator shall stop at the place nearest the intersecting roadway where the operator has a view of approaching traffic on the intersecting roadway.

Acts 1995, 74th Leg., ch. 165, Sec. 1, eff. Sept. 1, 1995.

Sec. 544.011. LANE USE SIGNS. If, on a highway having more than one lane with vehicles traveling in the same direction, the Texas Department of Transportation or a local authority places a sign that directs slower traffic to travel in a lane other than the farthest left lane, the sign must read "left lane for passing only."

Added by Acts 1997, 75th Leg., ch. 628, Sec. 1, eff. Sept. 1, 1997. Amended by Acts 1999, 76th Leg., ch. 62, Sec. 17.08, eff. Sept. 1, 1999.

Sec. 544.012. NOTIFICATION OF PHOTOGRAPHIC TRAFFIC MONITORING SYSTEM. (a) In this section:

(1) "Photographic traffic monitoring system" means a system that:

(A) consists of a camera and vehicle sensor installed to work in conjunction with an electrically operated traffic-control signal; and

(B) is capable of producing one or more recorded images that depict the license plate attached to a motor vehicle

that is not operated in compliance with the instructions of the traffic-control signal.

(2) "Recorded image" means an image that:

(A) depicts a motor vehicle; and

(B) is automatically recorded on a photograph or digital image.

(b) This section applies only to a municipality that pursuant to an ordinance of the municipality employs a photographic traffic monitoring system to enforce compliance with the instructions of traffic-control signals in the municipality.

(c) The municipality shall install signs along each roadway that leads to an intersection at which a photographic traffic monitoring system is in active use. The signs must be at least 100 feet from the intersection or located according to standards established in the manual adopted by the Texas Transportation Commission under Section 544.001, be easily readable to any operator approaching the intersection, and clearly indicate the presence of a photographic monitoring system that records violations that may result in the issuance of a notice of violation and the imposition of a monetary penalty.

(d) A municipality that fails to comply with Subsection (c) may not impose or attempt to impose a civil or administrative penalty against a person, including the owner of a motor vehicle or an operator, for a failure to comply with the instructions of a traffic-control signal located at the applicable intersection.

(e) Subsection (d) does not prohibit a peace officer from arresting or issuing a citation and notice to appear to a person whom the officer observes to have failed to comply with the instructions of a traffic-control signal located at the intersection.

Added by Acts 2007, 80th Leg., R.S., Ch. [653](#), Sec. 1, eff. September 1, 2007.

