

TEXAS PARKS AND WILDLIFE

A
Do-It-Yourself
Guide for
Feeders,
Houses and
Plants

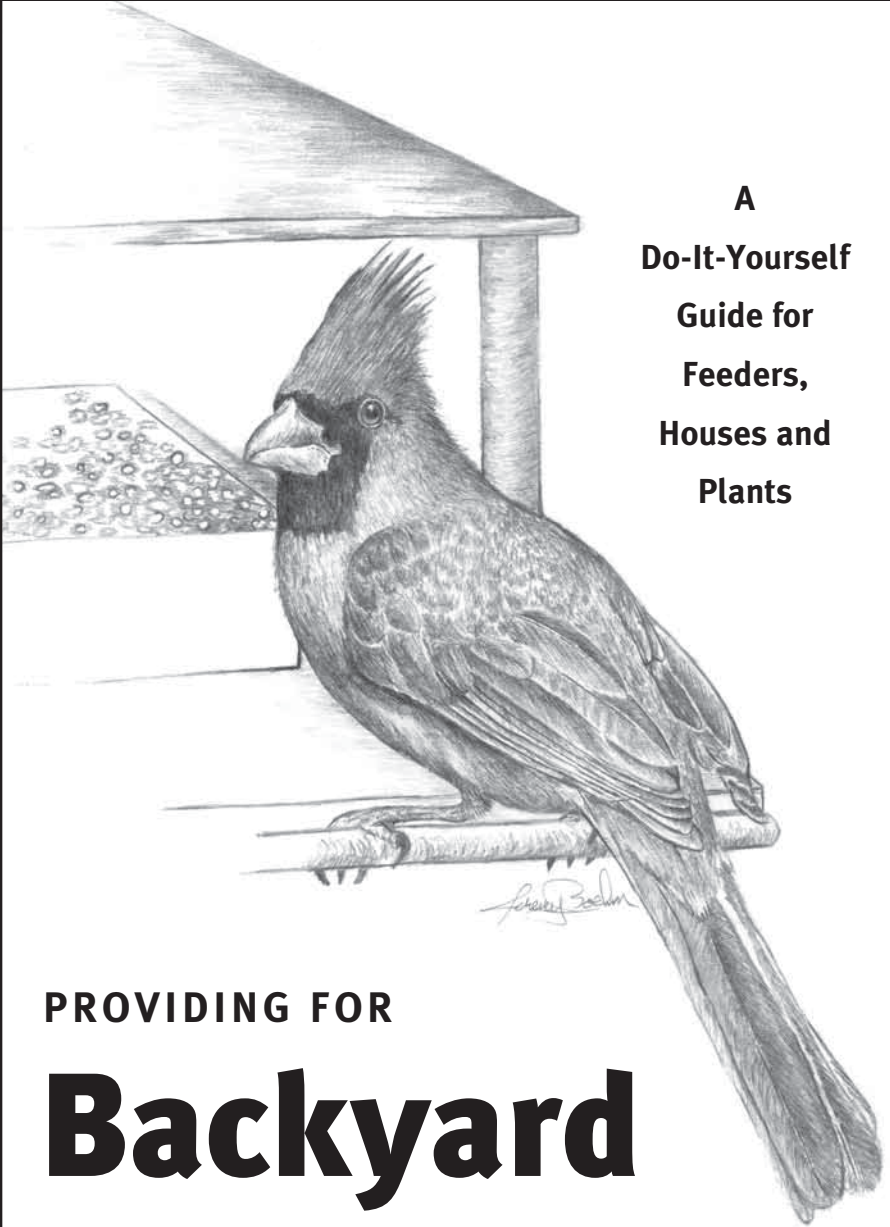

PROVIDING FOR

Backyard Wildlife



ABOUT THE AUTHOR

Walter Brown, a Master Naturalist from Central Texas, designed this brochure to assist people wanting to create habitat and features that will attract wild-life to their backyards. In addition to creating a beautiful habitat on their own properties, Walter and his wife, Jane, have been actively involved in restoration efforts in several locations across Texas.

For more information on the Master Naturalist program, please visit <http://txmn.org>

Providing for Backyard Wildlife

A Do-It-Yourself Guide for Feeders, Houses and Plants

BY WALTER BROWN

TABLE OF CONTENTS

Platform Bird Feeder	2
Platform Butterfly Feeder	3
Simple Squirrel and Dove Feeder	4
Suet Feeder	5
Solitary Bees	6
Pollinator Box.....	7
General Use Nesting Box.....	8
Nesting Platform	12
Butterfly Attracting Plants	14
Hummingbird Plants for Texas	16



In addition to items listed in this pamphlet, one other requirement is necessary to guarantee wildlife visits to your yard:

WATER! It doesn't have to be a fountain or pond; a pan with water for animals to drink is all that is necessary. Give them food, water and habitat, and enjoy watching wildlife in your backyard.

PLATFORM BIRD FEEDER

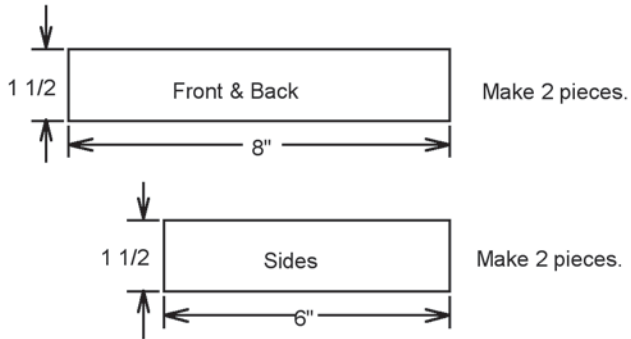

ASSEMBLY DETAILS

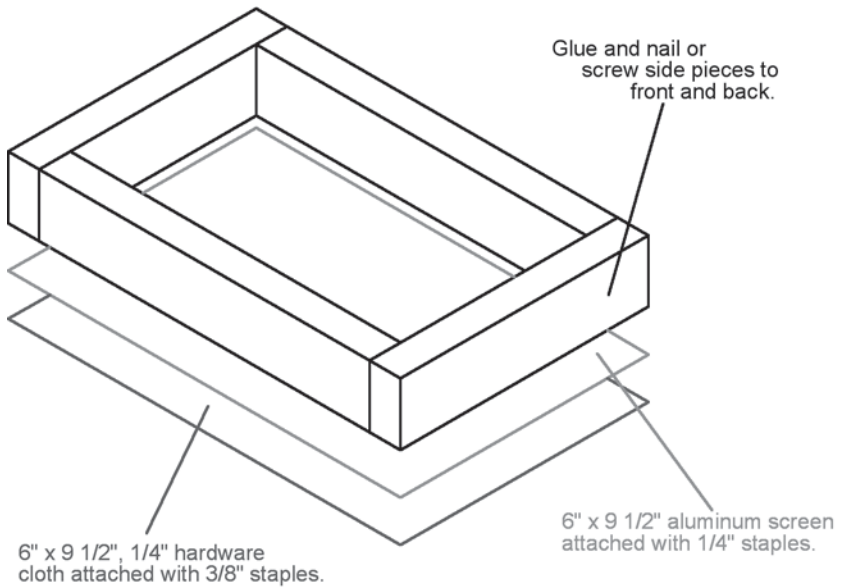

Feeder is attached to fence or other suitable surface using 90 degree brackets. Brackets may be installed vertically to attach to fence posts or poles, horizontally for attachment to fences.

PLATFORM BUTTERFLY FEEDER

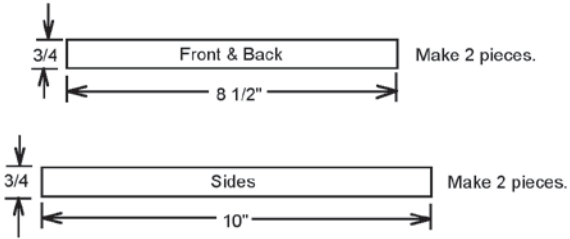

ASSEMBLY DETAILS

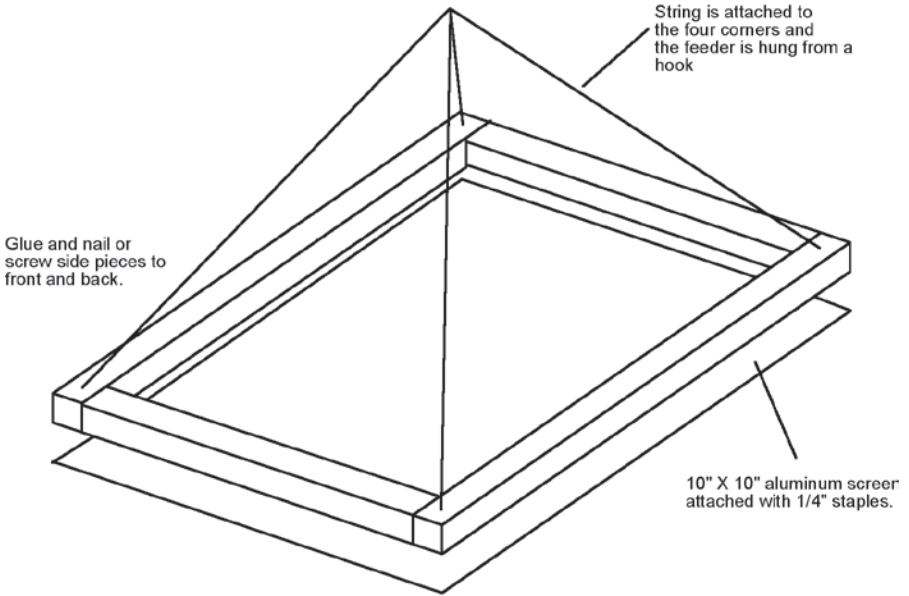

Place thin slices of orange or banana in the feeder to attract the butterflies. Particularly interesting to butterflies is very ripe banana.

SIMPLE SQUIRREL AND DOVE FEEDER

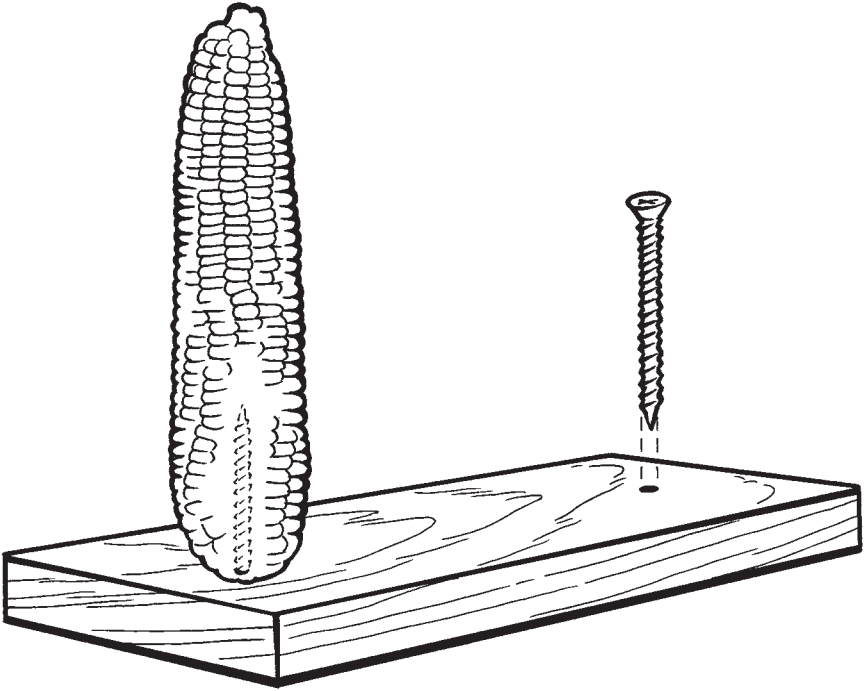

This simple corn cob squirrel and dove feeder is made of scrap wood and can hold multiple cobs of corn and be mounted at any point.

Use of a squirrel feeder will reduce problems with squirrels raiding bird feeders.

SUET FEEDER

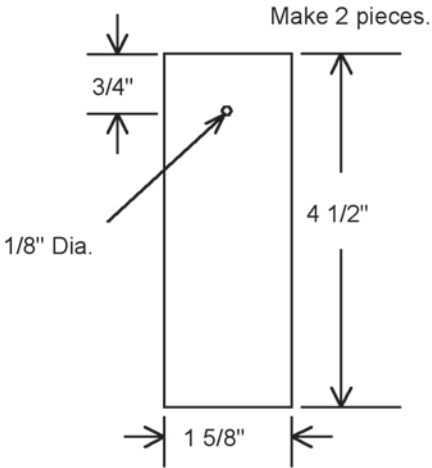

A 6 1/8" x 9" piece of 1/2" hardware cloth is required. The dimensions correspond to a piece that is 12 squares wide by 18 squares long.

Assembly is shown below. 3/8" staples are used to attach the hardware cloth.

A wire is looped through the holes in the side to act as a hanger for the feeder.

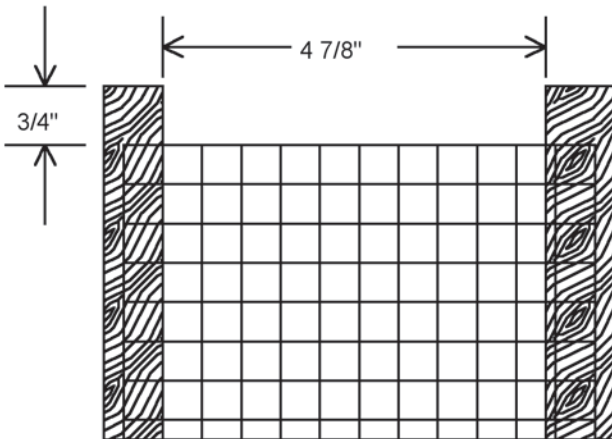

SOLITARY BEES

When we think of bees, we usually think of colonies of honey bees. But did you know that over 90% of bees are solitary? Common solitary bees include mason, carpenter, digger, sweat and plasterer bees. While these bees live alone, they almost always nest close to one another. The pollinator box gives these bees a ready made home to inhabit instead of nesting in your lawn furniture or urethane roofing material.

The female bee puts a mixture of pollen and nectar in the hole and lays an egg on top of the “food” and closes the hole. The egg hatches and the tiny grub consumes the food and pupates. The entire process takes only a week or two.

Because they don't have large nests and many offspring, solitary bees tend to be less defensive than social bees. Although the female is capable of stinging, she only does so when threatened. Solitary bees are considered beneficial because they pollinate crops and native plants.

Through experimentation, we have found that the pollinator boxes located in open areas seem to be used more than those that are obscured or protected by shrubs and other plants. Since few bees will read this, make several pollinator boxes and see what works best for your bees.

POLLINATOR BOX FOR SOLITARY BEES

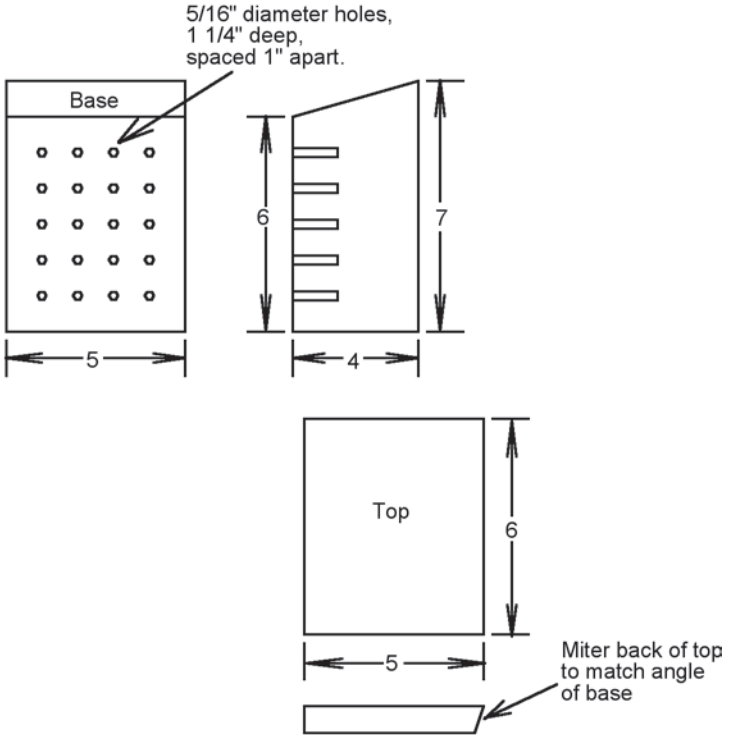

NOTES

1. Base is made from 1 1/2" glued up stock.
2. Top (optional) is glued and centered on box with miter cut aligned with back of box. Top is then nailed into position.
3. Dimensions may be varied to suit taste and materials available. Critical is the HOLE DIAMETER, HOLE DEPTH, and DISTANCE BETWEEN HOLES.

GENERAL USE NESTING BOX

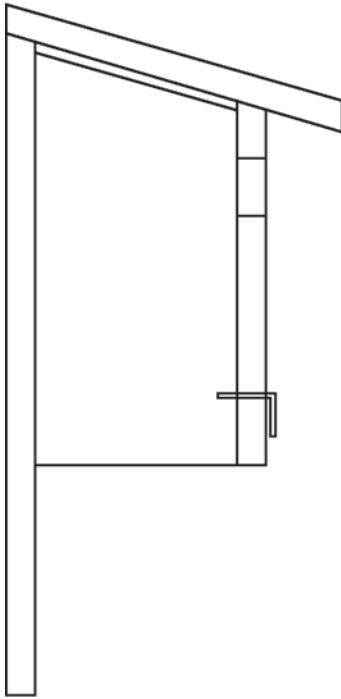

Side View

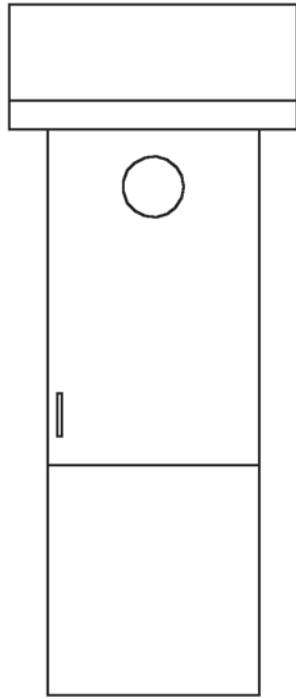

Front View

GENERAL USE NESTING BOX

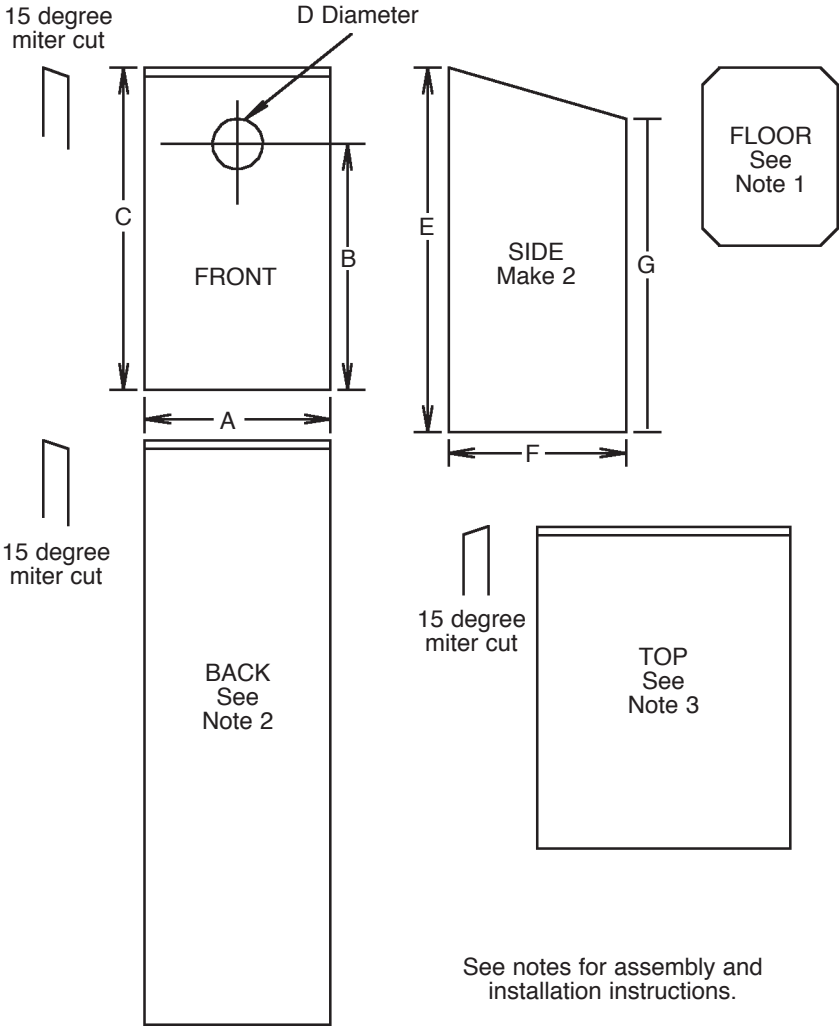

NOTES:

1. The FLOOR is cut snugly to fit the inside dimensions of the nest box. Four corners are cut off $1/2$ " to allow for drainage.
2. The length of the BACK is long enough to extend 10" below the nest box.
3. The ROOF extends 1" over the sides and 2" over the front of the box.

ASSEMBLY:

1. Fasten the FRONT to the LEFT SIDE. Ensure that the bottom edge of both pieces align before fastening. (The front will be $1/4$ " higher than the side as shown in the drawing).
2. Attach the BACK to the SIDE, making sure the back is $1/4$ " higher than the side.
3. Fit the FLOOR in the box so that it is $1/4$ " up from the bottom of the front and side pieces. Secure on 3 sides.
4. Position the remaining SIDE and secure with a $1\ 1/2$ " brad in the front and back. The brads are pivot points for opening the side for inspection, so they should be near the top and in a straight line from front to back.
5. With the RIGHT SIDE closed, drill a hole through the front and into the right side. Fit a nail or piece of wire into the hole as a catch (see drawing).

INSTALLATION:

1. Using conduit clamps and screws, attach a suitable length of $1\ 1/2$ " steel conduit to the BACK of the box. Two attachment points (top and bottom) are usually sufficient.

Place the conduit in the ground, making sure the distance from the ground to the entrance hole conforms to the dimension chart.

BIRD SPECIES	ENTRANCE										PLACEMENT
	A	B	C	D	E	F	G	ABOVE GROUND			
Eastern Bluebird	5 1/2"	7 1/4"	9 1/2"	1 1/2"	10 3/4"	5 1/4"	9 1/4"	5 - 10'			Woody, brushy borders of open fields
Carolina Chickadee	5 1/2"	7"	9"	1 1/8"	9 3/4"	4"	8 3/4"	6 - 15'			Edges of urban and suburban yards; brushy borders of fields
American Kestrel	9 1/2"	10 1/2"	13 1/2"	3"	15 1/4"	8"	13 1/4"	15 - 30'			Woody borders of open areas; lightly wooded forests
House Finch	7 1/2"	4"	6"	2"	7 1/4"	6"	5 3/4"	8 - 12'			Edges of urban and suburban yards
Screech Owl*	9 1/2"	10 1/2"	13 1/2"	3"	15 1/4"	8"	13 1/4"	15 - 30'			Lightly wooded forests; woody borders of open areas; wooded urban and suburban yards
Tufted Titmouse	5 1/2"	7"	9"	1 1/4"	9 3/4"	4"	8 3/4"	6 - 15'			Edges of urban and suburban yards; brushy borders of fields
Red-bellied Woodpecker*	7 1/2"	11"	13"	2 1/2"	14 1/4"	6"	12 3/4"	15 - 20'			Wooded areas
Bewick's Wren	5 1/2"	5"	7"	1"	7 3/4"	4"	6 3/4"	6 - 10'			Edges of urban and suburban yards; brushy borders of fields
Carolina Wren	5 1/2"	5"	7"	1 1/8"	7 3/4"	4"	6 3/4"	6 - 10'			Brushy areas near wooded lots
House Wren	5 1/2"	5"	7"	1"	7 3/4"	4"	6 3/4"	6 - 10'			Edges of urban and suburban yards; brushy borders of fields

* Add wood shavings or sawdust to a depth of 2-3 inches.

NESTING PLATFORM DETAILS

EASTERN PHOEBE, AMERICAN ROBIN, BARN SWALLOW

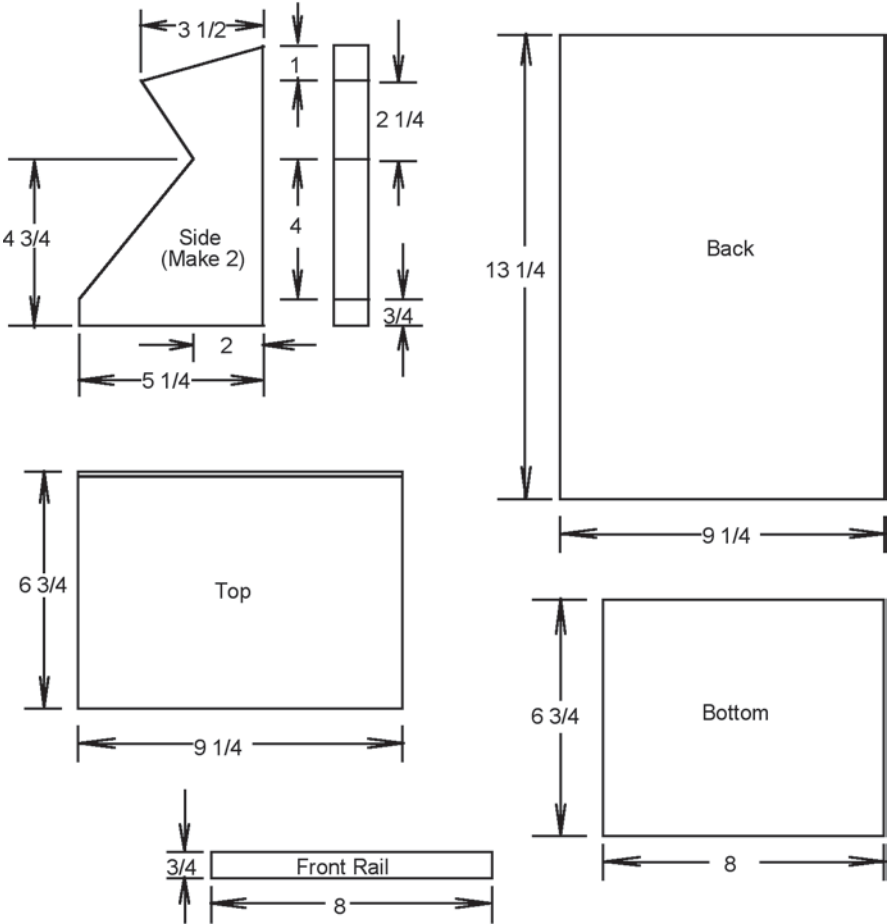

Rail stock is $\frac{1}{2}$ " thick.
All remaining stock is $\frac{3}{4}$ " thick.

NESTING PLATFORM INFORMATION

Extending the floor three to four feet will make a good platform for nesting Barn Swallows.

Barn Swallows – you either love their graceful flight or despise their mud nests attached just below the eaves on your home. These nests can be a problem and one way of dealing with them is to install a nesting platform, like that described on page 12, but extended to several feet per platform, on a building where you will not mind their nests. These graceful birds can be of great service to agricultural and residential areas alike, since they eat many of the flying insects that are “pests” in these areas.

Common Butterflies and their Favorite Plants

BUTTERFLY	LARVAL PLANT	NECTAR PLANT
Black Swallowtail	Dutchmen's breeches, dill, parsley	Fruit tree blossoms, lantana, asters
Bordered Patch	Sunflower, ragweed	Sunflower, ragweeds, straggler daisy
Buckeye	Purple gerardia, frog-fruit, ruellia	Purple gerardia, frog-fruit, ruellia
Cloudless Giant Sulpher	Senna species, partridge pea	Lantana, turk's cap, cardinal flower
Dogface	Leadplant, clover species	Verbena, salvias
Giant Swallowtail	Lime-prickly-ash, hop tree	Lantana, milkweed, honeysuckle
Great Southern White	Pepper grass, mustard family species	Various tastes
Great Purple Hairstreak	Mistletoe, eastern cottonwood, mesquite, sycamore	Poverty weed, Mexican plum
Gulf Fritillary	Passion-flower species, passion vine	Butterfly bush, lantana, asters
Goatweed Butterfly	Silver croton, one-seed croton, woolly croton	Tree sap, fruit juice, decaying wood
Hackberry Butterfly	Hackberry species	Dung, tree sap, rotting fruit
Julia	Passion-flower, passion vine	Lantana
Long-tailed Skipper	Legumes, mustards	Legumes, mustards



BUTTERFLY	LARVAL PLANT	NECTAR PLANT
Monarch	Milkweed species, milkweed vine	Lantana, frostweed, sunflowers
Painted Lady	Thistles, milfoil, mugwort	Thistles, mugwort, asters
Pipevine Swallowtail	Dutchman’s pipe	Lantana, phlox, cardinal flower, thistles
Queen	Milkweed species	Milkweed species, frog-fruit
Question Mark	Nettles, hackberries, cedar elm	Tree sap, milkweed, asters
Red Admiral	Nettles, pellitory	Milkweeds, asters
Snout Butterfly	Hackberry species	Dogwood, dogbane species, goldenrod
Tiger Swallowtail	Green ash, Mexican plum, eastern cottonwood	Butterfly weed, salvias, abelia, milkweeds
Variiegated Fritillary	Stiff-stem flax	Flax species
Zebra	Passion-flower, passion vine	Mist-flower, lantana, boneset, golden-eye

Hummingbird Plants for Texas

COMMON NAME

Flame Acanthus
 Red Yucca
 Cross Vine
 Trumpet Vine
 Desert Willow
 Coral Honeysuckle
 Buckeye
 Red Buckeye
 Purple Horsemint
 Wild Bergamot
 Tropical Sage
 Autumn Sage
 Big Red Sage
 Cedar Sage
 Mountain Sage
 False Indigo
 Anacacho Orchid Tree
 Eastern Coral Bean
 Carolina Jessamine
 Pink Root
 Heart-leaf Hibiscus
 Turk's Cap
 Globe Mallow
 Scarlet Muskflower
 Texas Clematis
 Wild Columbine
 Mexican Buckeye
 Cenizo
 Texas Lantana

SCIENTIFIC NAME

Anisacanthus wrightii
Hesperaloe parviflora
Bignonia capreolata
Campsis radicans
Chilopsis linearis
Lonicera sempervirens
Aesculus glabra v. arguta
Aesculus pavia
Monarda citriodora
Monarda fistulosa
Salvia coccinia
Salvia greggii
Salvia penstemonoides
Salvia roemeriana
Salvia regla
Amorpha fruticosa
Bauhinia congesta
Erythrina herbacea
Gelsemium sempervirens
Spigelia marilandica
Hibiscus cardiophyllus
Malvaviscus arboreus
Sphaeralcea angustifolia
Nyctaginia capitata
Cleamatis texensis
Aquilegia canadensis
Ungnadia speciosa
Leucophyllum frutescens
Lantana urticoides







Life's better outside.®

4200 Smith School Road
Austin, Texas 78744

PWD BK W7000-950 (9/11)

In accordance with Texas State Depository Law, this publication is available at the Texas State Publications Clearinghouse and/or Texas Depository Libraries.

TPWD receives federal assistance from the U.S. Fish and Wildlife Service and other federal agencies. TPWD is therefore subject to Title VI of the Civil Rights Act of 1964, Section 504 of the Rehabilitation Act of 1973, Title II of the Americans with Disabilities Act of 1990, the Age Discrimination Act of 1975, Title IX of the Education Amendments of 1972, in addition to state anti-discrimination laws. TPWD will comply with state and federal laws prohibiting discrimination based on race, color, national origin, age, sex or disability. If you believe that you have been discriminated against in any TPWD program, activity or event, you may contact the U.S. Fish and Wildlife Service, Division of Federal Assistance, 4401 N. Fairfax Drive, Mail Stop: MBSP-4020, Arlington, VA 22203, Attention: Civil Rights Coordinator for Public Access.

Printed on recycled paper.