



TEXAS TECH UNIVERSITY

Multidisciplinary Research in Transportation

Use of the Rational and Modified Rational Method for Hydraulic Design

Theodore G. Cleveland, David B. Thompson, Xing Fang

Texas Department of Transportation

NOTICE

The United States Government and the State of Texas do not endorse products or manufacturers. Trade or manufacturers' names appear herein solely because they are considered essential to the object of this report

Technical Report Documentation Page

| | | | | | |
|---|--|------------------------------|---|---|--|
| 1. Report No.: FHWA/TX-08/0-6070-1 | | 2. Government Accession No.: | | 3. Recipient's Catalog No.: | |
| 4. Title and Subtitle: Use of the Rational and Modified Rational Method for Hydraulic Design | | | | 5. Report Date: February 28, 2011 | |
| | | | | 6. Performing Organization Code: | |
| 7. Author(s): Theodore G. Cleveland, David B. Thompson, and Xing Fang | | | | 8. Performing Organization Report No. 0-6070-1 | |
| 9. Performing Organization Name and Address: Texas Tech University College of Engineering Box 41023 Lubbock, Texas 79409-1023 | | | | 10. Work Unit No. (TRAIS): | |
| | | | | 11. Contract or Grant No. : Project 0-6070 | |
| 12. Sponsoring Agency Name and Address Texas Department of Transportation Research and Technology Implementation Office P. O. Box 5080 Austin, TX 78763-5080 | | | | 13. Type of Report and Period Cover: Technical Report: September 2007- August 2010 | |
| | | | | 14. Sponsoring Agency Code: | |
| 15. Supplementary Notes: This study was conducted in cooperation with the Texas Department of Transportation and the Federal Highway Administration. | | | | | |
| 16. Abstract: This report examines the rational and modified rational methods using rainfall-runoff datasets developed from Texas watersheds for application to Texas Department of Transportation hydraulic design problems. A unified rational method for Texas (URAT) is proposed as an alternative to the conventional method in current use. URAT substitutes land-use specification, slope influence, and probability adjustments to runoff coefficients by a simple area-weighted coefficient based on functional impervious cover. URAT incorporates the effect of slope and probability adjustments in the specification of the watershed time of equivalence, a characteristic time that makes rational peak discharges and regression equation peak discharges equal at some specified recurrence interval. An extended application (example) is presented to illustrate how to use the URAT method for both peak discharge and hydrograph estimation. Several appendices document various approaches examined, and provide an extensive examination into the runoff coefficient. | | | | | |
| 17. Key Words Hydrology, hydraulics, rational method, modified rational method | | | 18. Distribution Statement No restrictions. Document available to public through National Technical Information Service, Springfield, VA 22161, www.ntis.gov | | |
| 19. Security Classif. (of this report) Unclassified | 20. Security Classif. (of this page) Unclassified | 21. No. Pages 157 | 22. Price | | |

This page intentionally left blank.

Use of the Rational and Modified Rational Methods for TxDOT Hydraulic Design

by
Theodore G. Cleveland
David B. Thompson
Xing Fang

with select contributions by
William H. Asquith

Research Report Number 0-6070-1

Project Number 0-6070

Use of the Rational and Modified Rational Methods for TxDOT Hydraulic Design

Sponsored by the Texas Department of Transportation
in cooperation with the
U.S. Department of Transportation Federal Highway Administration

Texas Tech Center for Multidisciplinary Research in Transportation
TechMRT
Texas Tech University
Box 41023
Lubbock, TX 79409-1023

February 2011

AUTHOR'S DISCLAIMER

The contents of this report reflect the views of the authors who are responsible for the facts and the accuracy of the data presented herein. The contents do not necessarily reflect the official view of policies of the Texas Department of Transportation or the Federal Highway Administration. This report does not constitute a standard, specification, or regulation.

PATENT DISCLAIMER

There was no invention or discovery conceived or first actually reduced to practice in the course of or under this contract, including any art, method, process, machine, manufacture, design or composition of matter, or any new useful improvement thereof, or any variety of plant which is or may be patentable under the patent laws of the United States of America or any foreign country.

ENGINEERING DISCLAIMER

This document is not intended for construction, bidding, or permit purposes.

TRADE NAMES AND MANUFACTURERS' NAMES

Neither the United States Government nor the State of Texas endorse products or manufacturers. Trade or manufacturers' names appear herein solely because they are considered essential to the object of this report.

This page intentionally left blank.

Acknowledgements

A project of the magnitude of TxDOT Project 0-6070 cannot be completed without the contributions of a large number of individuals beyond the principal investigators. The service of TxDOT engineers David Stolpa and George “Rudy” Herrmann began early in the conceptual stages of the project before a problem statement was even developed. Their contributions were supplemented by other TxDOT advisors, including Chuck Steed (Project Director), Amy Ronnfeldt, Elie Alkhoury, Kathy Dyer, Mark Mikulenska, Jaime Villena-Morales, and David Zwernemann.

CONTENTS

| | | |
|----------|--|-----------|
| 1 | Background | 1 |
| 1.1 | Introduction | 1 |
| 1.2 | Objectives | 2 |
| 1.3 | Organization | 3 |
| 2 | Technical Aspects of the Rational Method | 4 |
| 2.1 | The Rational Method | 4 |
| 2.1.1 | The Runoff Coefficient | 4 |
| 2.1.2 | The Drainage Area | 6 |
| 2.1.3 | The Characteristic Time | 7 |
| 2.1.4 | Summary and Important Implications for the Rational Method | 8 |
| 2.2 | The Modified Rational Method | 9 |
| 2.2.1 | Modified Rational Method Runoff Coefficient | 13 |
| 2.2.2 | Modified Rational Method Characteristic Time | 16 |
| 2.2.3 | Summary and Important Implications for the Modified Rational Method | 17 |
| 3 | A Proposed Unified Rational Method for Texas | |
| | Some Research Contributions by William H. Asquith | 18 |
| 3.1 | Runoff Coefficient for the Unified Rational Method for Texas | 19 |
| 3.2 | Example Computations and Discussion for Unified Rational Method for Texas | 23 |
| 3.2.1 | Statewide Watershed Time of Equivalence in Texas | 23 |
| 3.2.2 | Spatial Influence on 10-year T-star | 24 |
| 3.2.3 | Relative Influence of Recurrence Interval on T-star for Two Low-Slope Settings | 25 |
| 3.2.4 | Comparison of Unified Rational Method for Houston Metropolitan Area (Harris County) to Harris County Flood Control District Site-Runoff Curves | 26 |
| 3.2.5 | Using the Unified Rational Method for Computation of Peak-Streamflow Frequency | 26 |
| 3.2.6 | Computation of Upper Bound of Streamflow Estimates | 29 |
| 3.3 | Summary of a Proposed Unified Rational Method for Texas | 29 |
| 4 | Example Applications | 59 |
| 4.1 | Example Application for Peak Discharge Estimation (Forward Modeling) | 59 |
| 4.1.1 | Using a Conventional Rational Method | 59 |
| 4.1.2 | Using the Unified Rational Method for Texas | 62 |
| 4.1.3 | Comparison and Contrast of the Two Methods | 63 |

| | | |
|----------|---|------------|
| 4.2 | Application of the Modified Rational Method Parameterized by the Unified Rational Method | 63 |
| 4.2.1 | Non-Uniform Rainfall | 68 |
| 4.2.2 | Characteristic Time Assessment | 69 |
| 4.3 | Regression Equation Adjustments | 70 |
| 5 | Summary and Conclusions | 74 |
| 5.1 | Summary | 74 |
| 5.2 | Conclusions | 75 |
| 5.3 | Further Work | 76 |
| 5.3.1 | Additional Research | 76 |
| 5.3.2 | Implementation of Results | 77 |
| A | Literature Review | 84 |
| A.1 | Introduction | 84 |
| A.2 | Background | 85 |
| A.2.1 | Modified Rational Method — Background | 87 |
| A.3 | Rational Method Studies | 88 |
| A.3.1 | Modified Rational Method | 91 |
| A.3.2 | Concluding Remarks | 92 |
| A.4 | Characteristic Time | 93 |
| A.5 | The Runoff Coefficient | 95 |
| A.5.1 | Standard Rational Runoff Coefficients | 95 |
| A.5.2 | Runoff Coefficients Based on Water Budgets and Long-Term Basin Scale Studies | 99 |
| A.6 | Summary and Conclusions | 100 |
| B | Basin Development Factor | 102 |
| C | The iPar Program and Parsing of Rainfall and Runoff Events | 106 |
| C.1 | Inverting the Rational Method | 106 |
| C.1.1 | The Rational Method for Real Storms | 107 |
| C.1.2 | Regression of Time-R (Lag Time) | 111 |
| C.1.3 | Distribution of C_R and Relation between C_R and Drainage Area and Basin-Development Factor | 119 |
| C.2 | Algorithms of the Unified Rational Method Appendix | 121 |
| D | Modified Rational Method | 130 |
| D.1 | Modified Rational Method for Texas Watersheds | 130 |
| D.2 | Runoff Coefficients and Time of Concentration | 130 |
| D.3 | Estimated Runoff Hydrographs Using the MRM | 132 |
| D.4 | Comparison of MRM Results and Other Unit Hydrograph Methods | 137 |

LIST OF TABLES

| | | |
|-----|--|-----|
| 3.1 | Countywide values of mean-annual precipitation and OmegaEM parameter. | 30 |
| 3.2 | Countywide values of scale factor for unified rational method in Texas. | 34 |
| 3.3 | Countywide values of exponent on drainage area for unified rational method. | 41 |
| 3.4 | Countywide values of exponent on dimensionless main-channel slope. | 48 |
| 3.5 | Comparison of Dickens County example peak streamflow frequency estimates. | 54 |
| A.1 | Rational method runoff coefficients for various land uses (Standard C_{std}). | 96 |
| D.1 | Runoff coefficients used in the modified rational method. | 133 |

LIST OF FIGURES

| | | |
|-----|---|----|
| 2.1 | The MRM hydrograph when duration of rainfall is equal to T_c , from Wanielista and others (1997a). | 9 |
| 2.2 | The MRM hydrograph when duration of rainfall is greater than T_c . | 10 |
| 2.3 | The MRM hydrograph when duration of rainfall is less than T_c . | 11 |
| 2.4 | The instantaneous unit hydrograph of the rational method (Singh and Cruise, 1992). | 12 |
| 2.5 | The D -hour unit hydrograph of the rational method for $D < T_c$ (Singh and Cruise, 1992). | 12 |
| 2.6 | Cumulative distributions of the runoff coefficients C_v^{bc} (solid) and C_v^{lit} (dashed). | 15 |
| 2.7 | Modeled and observed peak discharge from C_v^{bc} (solid triangle) and C_v^{lit} (open circle) with timing parameters derived from the Kerby-Kirpich method. | 15 |
| 2.8 | Modeled and observed time to peak from C_v^{bc} (blue) and C_v^{lit} (black) with timing parameters from the Kerby-Kirpich method. | 16 |
| 3.1 | Intercept of regression by county for unified rational method in Texas | 55 |
| 3.2 | Exponent on drainage area for unified rational method in Texas | 56 |
| 3.3 | Exponent on dimensionless main-channel slope for unified rational method in Texas | 57 |
| 3.4 | Estimated peak-streamflow frequency curves of Unified Rational Method for Texas for the Dickens county example | 58 |
| 4.1 | Subdivision X Drainage to a Highway Culvert | 60 |
| 4.2 | Depth-Duration diagram for Harris County for the application example. Values are from maps in Asquith and Roussel (2004). Dashed line is used to extrapolate mapped values to unmapped durations. | 62 |
| 4.3 | Modified rational method runoff hydrograph for example drainage area. Applied storm duration is equal to the watershed characteristic time. | 65 |
| 4.4 | Modified rational method runoff hydrograph for example drainage area. Applied storm duration is equal to the watershed characteristic time $T^* = 10$ minutes. The peak discharge is $Q_p = 57.1$ cfs; the same as the URAT peak estimate. | 66 |
| 4.5 | Modified rational method runoff hydrograph for example drainage area. Applied storm duration $T_D = 60$ minutes is six times the watershed characteristic time of $T^* = 10$ minutes. | 67 |
| 4.6 | Modified rational method runoff hydrograph for example drainage area. Applied storm duration $T_D = 60$ minutes is six times the watershed characteristic time of $T^* = 10$ minutes. The peak discharge is $Q_p = 23.1$ cfs and is sustained for 50 minutes. | 68 |
| 4.7 | Modified rational method runoff hydrograph for example drainage area. Applied storm is non-uniform. $Q_p = 71.4$ cfs at 35 minutes. | 69 |

| | | |
|------|---|-----|
| 4.8 | Modified rational method runoff hydrograph for example drainage area. Applied storm is non-uniform. Watershed characteristic time increased to $T^* = 15$ minutes. $Q_p = 47.6$ cfs at 35 minutes. | 70 |
| 4.9 | Flowchart of application of Unified Rational Method for Texas. | 71 |
| 4.10 | Unified Rational Method – Forward Modeling Pathway. Result is a peak discharge estimate for a location in Texas for a specified frequency. | 72 |
| 4.11 | Unified Rational Method – Regression Equation Adjustment. Result is an adjusted peak discharge to reflect potential infrastructure additions in Texas for a specified frequency. | 73 |
| A.1 | Runoff generation in rational model. | 86 |
| A.2 | Modified Rational Formula Hydrographs by Poertner (1974). Adapted from Thompson (2006). | 88 |
| A.3 | Modified Rational Formula Hydrographs by Aron and Kibler (1990). Adapted from Thompson (2006). | 92 |
| A.4 | Runoff Coefficients for Texas from Ward (2005). | 100 |
| B.1 | Schematic of typical drainage basin shapes and subdivision into basin thirds. | 103 |
| C.1 | Overview of the rainfall- and runoff-parsing process using the iPAR program inclusive of definitions of selected metrics and computational verses conceptual availability with a specific focus on the square-root-of-area rule for first order estimation of time of concentration | 109 |
| C.2 | Screenshot of the iPAR program used to parse a historically significant flood event on May 24, 1981 at U.S. Geological Survey streamflow-gaging station 08156800 Shoal Creek at 12th Street, Austin, Texas, which has a drainage area of about 12.3 square miles. | 110 |
| C.3 | Screenshot of output for the parsed storm in Figure C.2 depicting the relation between the runoff coefficient of rational method computed in hind-casting mode and rainfall duration (characteristic time) for each successively incremented and aggregated, 5-minute window, which has been swept through the parsed rainfall (white window in top plot of figure C.2) to determine maximum rainfall intensity for indicated duration. | 112 |
| C.4 | Standard residual and diagnostic plots from the R environment using the <code>plot.lm()</code> function for the T_R regression equation. | 115 |
| C.5 | Relation between Time-R and drainage area and basin-development factor by watershed type for observed (median, plot A) values and those estimated by regression (plot B). | 118 |
| C.6 | Relation between C_R and drainage area and basin-development factor (BDF) by watershed type for median observed values. | 120 |
| D.1 | Cumulative distributions of the runoff coefficients C_v^{bc} (red) and C_v^{lit} (black). | 132 |
| D.2 | Modeled and observed peak discharge from C_v^{bc} and different timing parameters. | 134 |
| D.3 | Modeled and observed time to peak for C_v^{bc} and different timing parameters. | 134 |
| D.4 | Modeled and observed time to peak for C_v^{lit} and different timing parameters. | 135 |

| | | |
|------|---|-----|
| D.5 | Modeled and observed peak discharge from C_v^{bc} (green) and C_v^{lit} (black) with timing parameters derived from the Kerby-Kirpich method. | 136 |
| D.6 | Modeled and observed time to peak from C_v^{bc} (blue) and C_v^{lit} (black) with timing parameters from the Kerby-Kirpich method. | 136 |
| D.7 | Cumulative distribution of deviations (modeled Q_p - observed Q_p) from $Q_{p, obs}$ for $Q_{p, bc}$ using Kerby-Kirpich and C_{vbc} (black curve), $Q_{p, lit}$ using Kerby-Kirpich and C_{lit} (blue curve), $Q_{p, bc}$ using square-root-area and $C_{v, bc}$ (green curve) and $Q_{p, lit}$ using square root of the drainage area and C_{lit} (red curve). | 137 |
| D.8 | Unit hydrographs for USGS Streamflow-gaging Station 08048600. | 139 |
| D.9 | Hyetographs and hydrographs for USGS Streamflow-gaging Stations 08048500 and 08139000. | 140 |
| D.10 | Hyetographs and hydrographs for USGS Streamflow-gaging Station 08139000. | 141 |
| D.11 | Modeled and observed peak discharge from modified rational method (green) and HEC-1 unit hydrograph method (black). | 141 |
| D.12 | Modeled and observed peak discharge from modified rational method (green) and gamma unit hydrograph method (black). | 142 |
| D.13 | Cumulative distributions of differences of simulated Q_p between different methods. The green curve is for differences of simulated Q_p between Clark and MRM unit hydrographs, and the red curve is for differences of simulated Q_p between gamma and MRM unit hydrographs. | 142 |

1. BACKGROUND

The purpose of this report is to document TxDOT Research Project 0-6070 and to present guidelines to assist TxDOT designers in application of the rational method for development of design discharges and design hydrographs for small watersheds. This section of the report summarizes background information relevant to the research and explains the organization of the report.

1.1. Introduction

Texas Department of Transportation (TxDOT) analysts design roadways and proximal infrastructure. Each year, billions of dollars are spent on new construction¹. The infrastructure must accommodate storm-water drainage and conveyance.

The rational method (Mulvaney, 1850; Kuichling, 1889) is a tool for estimating peak (maximum) discharge from relatively small drainage areas. It [the rational method] predates the automobile age. TxDOT guidance is that the rational method should be applied to watersheds with drainage areas of 200 acres or less². The rational method relates peak discharge to contributing drainage area, average rainfall intensity for a duration equal to a watershed response time (typically the time of concentration), and a coefficient that represents hydrologic abstractions and hydrograph attenuation. The coefficient is generally termed the *runoff coefficient* and has a range from 0 (no peak discharge or runoff produced for a given rainfall intensity) to 1 (perfect conversion of rainfall intensity to a peak discharge). Equation 1.1 is representative of the rational method.

$$Q_p = CiA \tag{1.1}$$

In equation 1.1, C is the runoff coefficient (dimensionless if all other terms are in consistent length and time units) that relates the ratio of input volume rate (the product iA) to the output volume rate Q_p (peak discharge). The various assumptions of the method are listed in the TxDOT design manual, of particular note is that the runoff coefficient can vary with rainfall intensity i . The rainfall intensity i is, by originating arguments, the rainfall rate when the duration of rainfall equals the time of concentration.

¹As described by George “Rudy” Herrmann, TxDOT, on March 10, 2006, approximately 40 percent of construction dollars are spent on drainage-related facilities.

²Hydraulic Design Manual, p. 5-29, TxDOT 3/2004, located electronically at <http://manuals.dot.state.tx.us/dynaweb/colbridg/hyd> at the time of this writing.

The modified rational method extends the idea to parameterize simple runoff hydrographs (typically triangular), where the peak of the hydrograph is the peak discharge estimated by application of the rational method, and the time base of the hydrograph (start-to-finish) is twice the time of concentration.

Because the rational method remains in common use by TxDOT as well as the broader water-resources community, TxDOT research supervisory personnel issued a problem statement titled *Use of the rational and modified rational methods for TxDOT hydraulic design* in the spring of 2007.

A number of issues are associated with use of the rational method for estimating peak discharges for design of drainage structures, and when the modified rational method is used to estimate inflow hydrographs for design of best management practices. From the problem statement,

“Use of either method depends on the analyst’s estimate of the time of concentration and the runoff coefficient. Both of these estimates can vary substantially depending on watershed conditions. Therefore, research to document appropriate values is needed.”

In addition to estimates of both time of concentration and runoff coefficient, design-rainfall intensity has substantial impact on computations using the rational method. An initial investigation of the rational method, in the context of watershed scale, was reported by Thompson (2007). That work was done using data from about 20 Texas watersheds, mostly rural (undeveloped). Thompson (2007) reported

“For simple watersheds, the rational method may be applied when only an estimate of the peak discharge from the runoff hydrograph is required. Watershed drainage area does not seem to be an important consideration³. However, this observation must be tempered with a caveat that only 20 watersheds were examined. Furthermore, watershed complexity was not examined as part of this research. Because the rational method is a simple procedure, application of the method to a complex watershed would be an error of judgment and may result in substantial errors in estimated design discharge. Further study through expansion of the study database also is in order.”

This research project expanded along these various themes — the estimate of time, the runoff coefficient, and scale.

1.2. Objectives

The project objectives (from the problem statement) are:

“... to evaluate the appropriateness of using both rational and modified rational methods for small watershed design, evaluate the tabulated values of the runoff coefficient, and construct guidelines for TxDOT analysts for selection of appropriate parameter values for Texas watershed conditions. ”

³The area of course matters in producing a correct volume balance, but areas far larger than typically used had no apparent ill effect on the method for estimating peak discharge.

Therefore, using the database developed by Asquith and others (2004), supplemented with data added after publication of Asquith and others (2004) for the Houston, Texas, region, an evaluation of the rational method and the modified rational method was made.

1.3. Organization

The report is organized into a technical review of the method and application of the method. A considerable effort at unification and simplification is represented in this report. Additionally, a collection of appendices are included that examine in more detail much of the actual analysis performed in the research.

The appendices document the various research paths that were examined during the course of the project. Some of these paths represent considerable effort that later was incorporated into other parts of the project. Inclusion of these paths of research is important to establish an archival documentation of the research methods, mostly for the sake of completeness, but also as guide posts to future researchers. Furthermore, the appendices add to the technical support for the applications, but by moving the research details out of the main report body, the authors feel the report is more useable.

The report itself is a tool to be used; the appendices are intended as supplemental reading and technological back-up for the methods suggested in the report.

2. TECHNICAL ASPECTS OF THE RATIONAL METHOD

2.1. The Rational Method

The rational method dates to as far back as Mulvaney (1850), but Kuichling (1889) presents a more comprehensive treatment of the method. Another early recognized “author” of the method is Lloyd-Davies (1906). Much of the work in this research independently, and quite unexpectedly, validates Kuichling (1889) — his treatise is recommended historical reading!

The rational method conceptualizes the runoff process using the following plausibility argument. If the product of rainfall intensity and area is constant over the time interval required to completely drain a watershed (or longer), then the runoff rate would be equal to this product of rainfall intensity and area — a statement of rate equilibrium [$\dot{I} = \dot{O}$]. A mass balance relating the input and output (under such equilibrium) is indeed the familiar rational runoff formula, $Q_p = CiA$, where C is the runoff coefficient (dimensionless if all other terms are in consistent length and time units) that relates the ratio of input volume rate, iA , to the output volume rate, Q_p .

Some assumptions historically associated with this formula for practical application are

1. Rainfall intensity is constant for a time period at least as long as the characteristic time of the watershed.
2. The runoff maximum occurs when the rainfall intensity lasts at least as long as the characteristic time.
3. The contributing area is constant during the storm.
4. The runoff coefficient, C , is constant during the input event.

In practice the runoff coefficient is typically estimated from tabular data or from runoff studies that relate the volume of runoff to the volume of precipitation (Wanielista and others, 1997a). The latter approach (use of runoff and rainfall ratios) is the conceptual source of the concept of the volumetric runoff coefficient.

2.1.1. The Runoff Coefficient

The runoff coefficient is a value between zero and one that relates the input rate, iA , to the peak discharge rate, Q_p . The rainfall intensity is governed by the characteristic time of the watershed. Determination of a runoff coefficient from analysis of rainfall and runoff data logically proceeds

along two distinct lines of thought. The first is to invert the rational method equation and solve for the coefficient value. The second is to determine the coefficient value as the ratio of runoff volume to precipitation volume — a volumetric runoff coefficient.

The inverted runoff coefficient, C^k , is uniquely a function of peak discharge, Q_p^k , and rainfall intensity, I^k . C^k is defined for the k th event as

$$C^k = \frac{Q_p^k}{I^k(t_d) \times A} \quad (2.1)$$

where $I^k(t_d)$ is the maximum average rainfall intensity¹ for a rainfall duration of t_d . The selection of t_d is non-trivial and is discussed in greater detail later in this chapter.

The volumetric coefficient, C_v^k , is defined for the k th event as

$$C_v^k \equiv \frac{\text{total runoff for event, } P_k}{\text{total rainfall for the event, } R_k} \quad (2.2)$$

The C_v^k coefficient is alluded to in Wanielista and others (1997a) and certainly in many other other sources, although it [the coefficient] is not usually qualified as “volumetric.” Other sources where a volumetric concept is implied (and logically could serve as a basis for runoff coefficient estimation) are maps of annual precipitation depths and runoff depths (at basin scale) Moody and others (1986). The ratio of these maps (runoff depth to rainfall depth for a location) is a volumetric runoff coefficient. An example of such a map of volumetric runoff coefficients is presented in Appendix A.

The researchers emphasize that the “runoff coefficient” of the rational method is not phenomenologically consistent with the concept of the “volumetric runoff coefficient” yet the two seem to be used interchangeably in the literature. Probably the most plausible origin of the two types of coefficients stems from literature on the modified rational method where the usual definition of runoff coefficient is “a dimensionless ratio of the total volume of runoff to the total volume of rainfall.”

The runoff coefficient conventionally exists on the interval (0, 1] yet if rainfall averaging time is too large then coefficients greater than 1 may be computed when applying Equation 2.1 to recover coefficients from observations. One interpretation is the coefficient is a survival probability a unit rainfall rate for meaningful averaging times. Another interpretation, initially articulated by Kuichling (1889) and repeated in various contexts by subsequent authors, is that the coefficient is a proportion of total drainage area that is functionally impervious during the event of interest (contributing area concept). In either interpretation, and as a practical matter for use, the upper bound of the coefficient is unity, and because runoff has been produced, the lower limit is nonzero.

The concept of functionally impervious is introduced here as yet another way to conceptually understand the runoff coefficient. A functionally impervious surface is a surface, perhaps permeable, that functions as if impermeable. An example would be fully saturated soil horizon in the watershed whose infiltration capacity is already exceeded; further precipitation on these surfaces produces only

¹In this work, units are inches per hour.

runoff, with a negligible amount of additional infiltration. In this context, the runoff coefficient represents a composite value (Kuichling, 1889, p. 41–42) of the balance between pervious, functionally impervious surfaces, and functionally pervious “impervious surfaces.” In practice, the runoff coefficient could be estimated simply from the percent impervious cover of the watershed with appropriate upper and lower bound restrictions. Kuichling (1889, p. 41–42) uses just this sort of composite C value with $C_{base} = 0.15$ and $C_{impervious} = 1$ and prorated by area weighting.

The runoff coefficient in the engineering literature also is conventionally used to account for watershed losses, consider for example

“... the runoff coefficient can vary with soil moisture conditions and the period of time and volume of runoff (Wanielista and others, 1997a).”

The quote suggests the idea of composited C values to reflect behavior of different parts of the watershed to the overall runoff signal. Composite C values, where different portions of a watershed are assigned different runoff coefficients, exists as early as Kuichling (1889, p. 21). Many tabulated runoff coefficients associated with land use distinctions available in the engineering hydrology literature are reported in Appendix A. While these tabulated values are consistent with back-computed values the unified rational method described herein dispenses with such tables in favor of an adaptation of the area weighted functionally impervious approach of Kuichling (1889). Much of the variability implied in the coefficient tables is instead transferred into the estimation of time in the unified rational method.

2.1.2. The Drainage Area

The rational method lacks a firm physical loss model, yet initial abstraction exists and increases with watershed size (Asquith and Roussel, 2007, p. 23). The general phenomenological argument is that depression storage and channel storage, both in particular, increases as watershed drainage area increases. The implication for the rational method is that there is a watershed size limit beyond which the initial abstraction of the watershed can no longer be ignored — that is there is some upper bound of size for rational method applicability.

The evidence that the researchers have amassed from processing of more than 10,000 storms from nearly 200 watersheds of considerable size variation² is that observed runoff coefficients are smaller than those in literature. Some of this difference is attributable to satisfaction of abstractions, storage, and infiltration. Kuichling (1889, p. 24) states “should the solid surface be at all absorbent, the rain has to furnish the quantity of water necessary to saturate it.” (At saturation, initial abstraction and arguably infiltration losses are negligible; but it could take considerable time on larger watersheds to reach this equilibrium.)

The typical recommended upper bound for drainage area for use in the rational method is typically on the order of 200 – 300 acres. A justification for this bound is that watershed size should be small enough to ensure a mass balance for the runoff coefficient, in the absence of a loss model, to faithfully capture any loss processes functioning within the watershed. An additional supporting

²Many of these watersheds are admittedly larger than usually recommended for rational method application.

justification is that watersheds with long travel times (large characteristic times) are unlikely to ever have constant intensity over that time period, hence the favoring of smaller watersheds for use of the method. Depression storage on even a small watershed could influence this justification, but typically for the watersheds of the scale intended for the rational method many are engineered watersheds in which depression storage is often graded out.

Another interpretation is that the suggested size also is a lower limit on other techniques of runoff estimation. The Asquith and Roussel (2007, p. 27) gamma unit hydrographs are inherently 5-minute unit hydrographs because of the time step chosen in the analysis. If hydrograph shape is not adjusted such that the hydrograph peak occurs on an integer multiple of the computational time step, then 5 to 16 multiples of the time step are needed for reliable computation of peak discharge. For sake of argument, suppose 8 multiples are appropriate to use — there are 8 time steps (ordinates of the unit hydrograph) prior to peak. Therefore, the approximate time to peak is 40 minutes. Using the square-root-of-area rule, then the equivalent area of 40 minutes is $(40/60)^2 \times 640 = 280$ acres. Therefore, unit hydrograph methods dependent on fixed hydrograph shape are problematic in practice for watersheds less than about 0.3 square miles — use of rational method instead is appropriate.

The previous paragraph suggests that the apparently arbitrary limit of 200 acres from “engineering consensus” is in fact a reasonable guideline based on the nature of the discrete mathematics (non-instantaneous hydrograph modeling) of unit hydrograph computation in practice. However, the paragraph also suggests that there is considerable flexibility in the upper limit. Watersheds beyond 1 square mile could be deemed amenable to rational method application in certain circumstances, and rigid adherence to a 200 acre limit is unnecessary.

2.1.3. The Characteristic Time

The rational method requires an estimate of watershed characteristic time, typically the “time of concentration”, that establishes the duration of a rainfall input required for the system to reach equilibrium. The characteristic time is also used in computing the rainfall intensity from depth-duration-frequency information. The observation that time is intertwined was not lost in the early manifestations of the rational method; (Kuichling, 1889, p. 40) states:

“The element of time, therefore, enters twice into the determination of flood-volume, and from the relation between duration and maximum intensity of rainfall in this locality heretofore established, we may accordingly find the duration of that particular rainfall for which the sewer discharge becomes an absolute maximum.”

The watershed slope affects characteristic time and has no substantial influence on runoff coefficients; hence the dependence of runoff coefficients on slope that appears in the literature is artificial and confounding. The statement that slope does not affect runoff coefficients is not to say that peak discharge is not affected by watershed slope — indeed steeper slopes yield smaller times and a proportionate increase in rainfall intensity for a given rainfall frequency.

2.1.4. Summary and Important Implications for the Rational Method

Application of the rational method in practice requires evaluation of the intensity-duration-frequency (IDF) information for the watershed characteristic response time. An underlying implication is that the relative frequency (probability) of runoff is the same as the relative frequency (probability) of the rainfall used in the rational method. The structure of the intensity equation used by TxDOT designers³ is

$$i = \frac{b}{(T_c + d)^e}, \quad (2.3)$$

where i is the average rainfall rate (L/T) for the rainfall averaging time, T_c , (L/T), and b , d , and e are parameters used to calibrate Equation 2.3 for a specific locale. The terms of Equation 2.3 are identical to those in the TxDOT Hydraulics Design Manual (page 5–31). The term T_c in the Design Manual is referred to as the *time of concentration*. The event duration or averaging time is in fact a watershed characteristic and not a rainfall characteristic; yet it [T_c] is required to determine an intensity — exactly the double appearance of time Kuichling (1889) alluded to in his extensive treatise on the method.

Current application of the method, as per the TxDOT Hydraulic Design Manual⁴, is

1. Determine drainage area,
2. Determine time of concentration,
3. Verify that the rational method assumptions are applicable for the situation (particularly storage and watershed size),
4. Determine e , b , and d values for desired design frequency. Alternatively use Asquith and Roussel (2004) to determine the rainfall depth for the time of concentration and desired design frequency,
5. Compute rainfall intensity,
6. Select runoff coefficients, and
7. Calculate estimated peak discharge.

Steps 1, 3, 4, and 7 are straightforward. Steps 2, 5, and 6 are the crucial steps in the method, especially with the following considerations: The determination of the time of concentration is non-trivial. Determination of the time of concentration ultimately selects the rainfall intensity. The selection of runoff coefficients also is non-trivial; in part because of what these coefficients really represent, and in part because of the overall effect on the outcome their numerical value may have.

The research analyzed thousands of storms in examining the behavior of rainfall-runoff. The vast majority of the storms processed are storms having comparatively high frequency (less than 2-year

³The TxDOT Hydraulic Design Manual is available on the internet at the uniform resource locator of <http://onlinemanuals.txdot.gov/txdotmanuals/hyd/index.htm> at the time of this writing.

⁴http://onlinemanuals.txdot.gov/txdotmanuals/hyd/the_rational_method.htm

annual recurrence intervals). Recurrence intervals for most infrastructure design dependent on peak streamflow criteria are larger. Hence, the rainfall intensities processed by the researchers are likely to be comparatively small relative to the needs of a designer.

2.2. The Modified Rational Method

The modified rational method (MRM) is a method to parameterize simple runoff hydrographs. The MRM produces a runoff hydrograph (and volume) while the original rational method produces only the peak design discharge. The rational method was originally developed for estimating peak discharge for sizing drainage structures, such as storm drains and culverts. The MRM, which has found widespread use in engineering practices since the 1970s, is typically used to size detention/retention facilities for a specified recurrence interval and allowable outflow rate.

The MRM was developed (Poertner, 1974) with the intent of using the rational method for hydraulic structures involving storage on small watersheds. The term “modified rational method analysis” refers to “a procedure for manipulating the basic rational method techniques to reflect the fact that storms with durations greater than the normal time of concentration for a basin will result in a larger volume of runoff even though the peak discharge is reduced” (Poertner, 1974, p. 54). Under this concept, the basic hydrograph is a triangle (Figure 2.1) generated by a rainfall duration D equal to the time of concentration T_c , and with a base equal to $2T_c$.

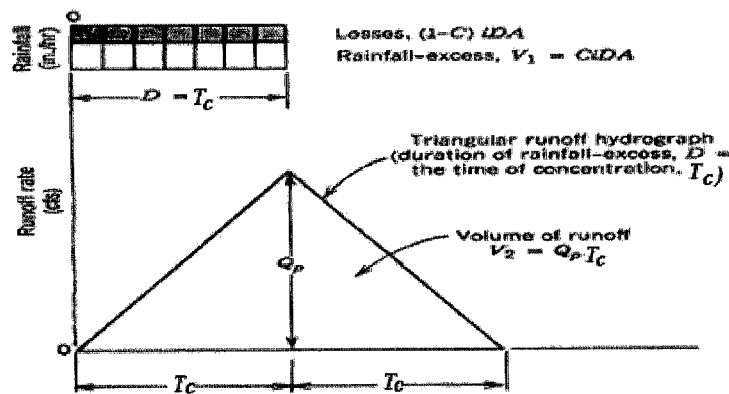

Figure 2.1: The MRM hydrograph when duration of rainfall is equal to T_c , from Wanielista and others (1997a).

The MRM is based largely on the same assumptions used in the conventional rational method and is a conceptual extension of the rational method for development of runoff hydrographs (Viessman and Lewis, 2003). For the MRM a stormwater runoff hydrograph from a design storm intensity is approximated as either a triangular or trapezoidal hydrograph (depending on the relation between storm duration and time of concentration) with the peak (or plateau) discharge less than or equal to CiA , where C , i , and A have their conventional meaning.

If the storm duration is equal to time of concentration, the resulting hydrograph is triangular in shape (Figure 2.1) with a peak discharge of $Q_p = CiA$. If the storm duration is greater than the watershed time of concentration, the resulting hydrograph is trapezoidal in shape (Figure 2.2) with a uniform maximum (plateau) discharge determined from the conventional rational method ($Q_p = CiA$) for the difference between the time of concentration and storm duration. The linear rising and falling limbs each have duration of T_c (Walesh, 1989; Viessman and Lewis, 2003).

If the storm duration is less than the watershed time of concentration, then the resulting hydrograph is trapezoidal in shape with a maximum uniform plateau discharge being some fraction of $Q_p = CiA$ from the end of rainfall to the time of concentration. This value is denoted as Q'_p . The linear rising and falling portions of the hydrograph each has duration of $D < T_c$ as shown in Figure 2.3. Smith and Lee (1984) and Walesh (1989) reported the MRM hydrograph for the case when the storm duration is less than the time of concentration of the drainage area and stated that Q'_p can be calculated using Equation 2.4,

$$Q'_p = CiA \frac{D}{T_c}. \quad (2.4)$$

The value i in Equation 2.4 is identical in meaning and interpretation as in Equation 2.3, and like in the rational method, T_c is a watershed property.

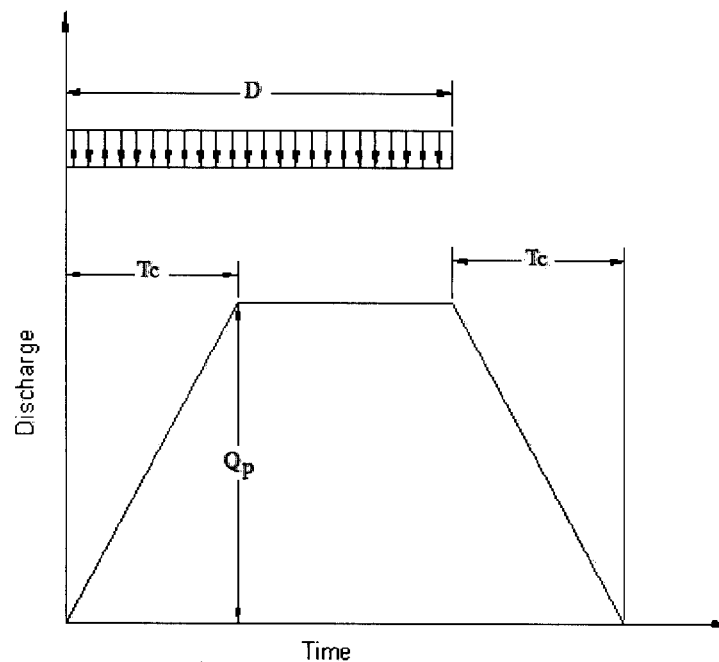

Figure 2.2: The MRM hydrograph when duration of rainfall is greater than T_c .

Smith and Lee (1984) examined the rational method as a unit hydrograph. They noted that if the rate of change of the contributing area is constant so that the accumulated tributary area increases and decreases linearly and symmetrically with the time, then the instantaneous unit hydrograph

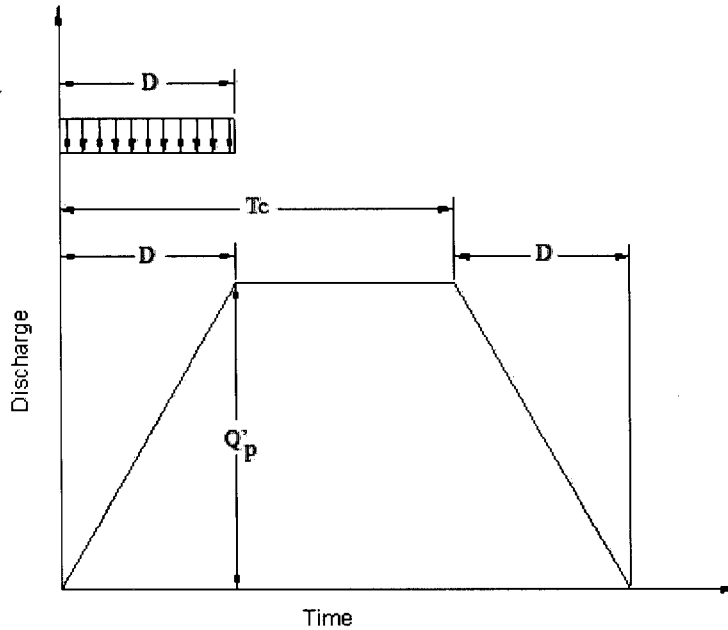

Figure 2.3: The MRM hydrograph when duration of rainfall is less than T_c .

(IUH) response function, $u(t)$, is of rectangular shape (Figure 2.4),

$$u(t) = \frac{dA}{dt} = \frac{A}{T_c}. \quad (2.5)$$

Using the rectangular response function presented as Equation 2.5 in conjunction with uniform rainfall intensity, Smith and Lee (1984) derived the resulting direct runoff hydrographs, $Q(t)$ (in watershed depth per time), by convolution as,

$$Q(t) = \int_0^t i_e(\tau)u(t - \tau)d\tau, \quad (2.6)$$

where τ is the time used for integration and $i_e(\tau) = Ci$ is the excess rainfall intensity (averaged as in the rational method). The decoupling of rainfall into excess rainfall by use of $i_e(\tau) = Ci$ is fundamental in the interpretation of the MRM as a special case of unit hydrograph theory. Of importance, because mass must be preserved, C in this context is a volumetric runoff coefficient. Two types of outflow hydrographs, either triangular (Figure 2.1) or trapezoidal (Figures 2.2 and 2.3) shape, were obtained by Smith and Lee from Equation 2.6 depending upon the duration of rainfall. Chien and Saigal (1974) used a similar approach to derive three runoff hydrographs depending on rainfall duration and time of concentration although there was an error for the case of $D < T_c$ as reported by Welsh (1975).

Wanielista and others (1997a) discussed the rational hydrograph in context of the contributing area and assumed that the contributing area varies linearly with time. Wanielista and others derived the

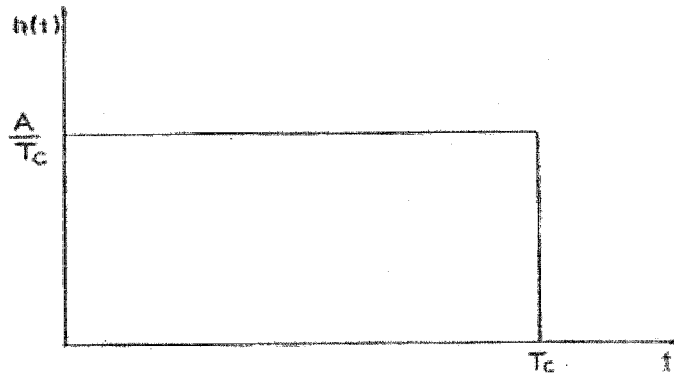

Figure 2.4: The instantaneous unit hydrograph of the rational method (Singh and Cruise, 1992).

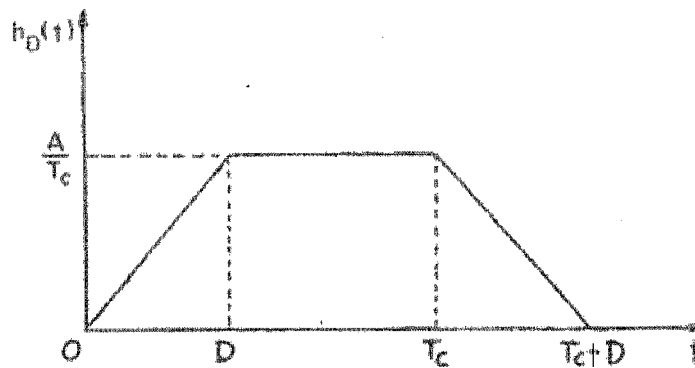

Figure 2.5: The D -hour unit hydrograph of the rational method for $D < T_c$ (Singh and Cruise, 1992).

triangular hydrograph (Figure 2.1) when $D = T_c$ and the trapezoidal hydrograph (Figure 2.2) when $D > T_c$ from the rational method, similar to results presented by Chien and Saigal (1974); Welsh (1975).

Guo (2000, 2001) proposed and developed a rational hydrograph method (RHM) that can be applied for continuous nonuniform rainfall events. Furthermore, Guo applied the RHM to extract both the runoff coefficient and the time of concentration from observed runoff events through optimization. Guo considered the time of concentration as the system memory (Singh and Cruise, 1992) and used a moving average window to estimate uniform rainfall intensity for the application of the rational method to determine hydrograph ordinates. If the rainfall is uniform, the RHM will result triangular or trapezoidal hydrographs, similar to those shown in Figures 2.1 and 2.2. Guo's RHM was used by Hayes and Young (2005) to estimate peak discharge, time of concentration, and runoff coefficient for small basins in central Virginia with observed nonuniform rainfall data.

The RHM developed by Guo (2000, 2001) is not strictly a unit hydrograph because it violates the mass conservation principle when applied to nonuniform rainfall distributions. In contrast, the MRM unit hydrograph is mass conservative. However, the RHM is a practical procedure to compute the moving average rainfall intensity for the application of rational formula, and indirectly links the modified rational approaches to unit hydrograph theory.

Singh and Cruise (1992) present a systems-based approach for the analysis of the rational formula. Like Smith and Lee (1984), they assumed the watershed is represented as a linear, time-invariant system whose instantaneous unit hydrograph (IUH) is a uniform rectangular distribution of base time equal to the time of concentration of the basin (Figure 2.4). They used the convolution to derive the S-hydrograph and D -hour unit hydrograph for the rational method as shown in Figure 2.5. The unit hydrograph shown on Figure 2.5 represents the unit hydrograph that results from the modified rational method. This unit hydrograph has a symmetric trapezoidal shape when the duration is less than the time of concentration ($D < T_c$).

Extending the original rational method for computing the peak discharge to the modified rational method for developing runoff hydrographs only assumes an ideal watershed with equal time-area histogram and no watershed storage or hydrograph attenuation. Chien and Saigal (1974) state,

In all cases, linear variation in the rising limb and the receding limb of the subhydrograph for a sufficiently small drainage basin is assumed. It is recognized that these variations are, in fact, curvilinear; however, in review of the crudeness in predicting the curvilinear variations and linear approximation in observed experimental hydrographs (Morgali 1970; Schreiber and Bender 1972), the assumption of linear variations is considered practical.

The linear channel or constant time-area histogram as basic assumption for the modified rational method UH is a simplistic approximation for watersheds, especially when the drainage area becomes large. Watersheds with a nonuniform time-area histogram (those that cannot be represented by a linear channel approximation) will not produce the same unit hydrographs predicted by the MRM even for the uniform rainfall condition. With these caveats in mind, the MRM is a useful tool for appropriately sized watersheds, with the implicit understanding that the runoff coefficient is a volumetric runoff coefficient, and simply serves to convert rainfall into excess rainfall.

Many authors suggest the rational method, and especially the modified rational method, requires a uniform rainfall distribution for application. This requirement is incorrect based on the interpretation of the MRM as a unit hydrograph method. The MRM can be used to generate runoff hydrographs for any nonuniform rainfall events using unit hydrograph convolution. The conclusion that the modified rational method is a unit hydrograph (UH) method is fundamentally important and this linkage establishes a continuity of methodology from very small watershed to rather large watersheds.

2.2.1. Modified Rational Method Runoff Coefficient

The precise definition and subsequent interpretation of the runoff coefficient in the MRM varies. The value can be defined either as the ratio of total depth of runoff to total depth of rainfall or as

the ratio of peak rate of runoff to rainfall intensity for the time of concentration (Wanielista and Yousef, 1993). However, because the MRM generates a hydrograph and should preserve volumes, the method implies that the runoff coefficient is conceptually a volumetric runoff coefficient.

The research examined two volumetric runoff coefficients for the application of the modified rational method. The first is a watershed composite literature-based coefficient (C_v^{lit}), derived using the land-use information for the watershed and published C_v^{lit} values for various land-uses. Details of the examination are presented in Appendix D.

The composite C_v^{lit} value assigned to a watershed is the area-weighted mean value of individual grid-cell values, using,

$$C_v^{\text{lit}} = \frac{\sum_{i=1}^n C_i A_i}{\sum_{i=1}^n A_i}, \quad (2.7)$$

where $i = i^{\text{th}}$ sub-area with a particular land-use type, n is the number of land-use classes in the watershed, C_i is the literature-based runoff coefficient for the i^{th} land-use class, and A_i is the area of the i^{th} land-use class in the watershed. This runoff coefficient may not necessarily preserve observed runoff volumes from observed rainfall.

The second runoff coefficient is a back-computed volumetric runoff coefficient, C_v^{bc} , determined by preserving the runoff volume and using observed rainfall and runoff data. C_v^{bc} is estimated by the ratio of total runoff depth to total rainfall depth for individual observed storm events. The determination and comparison of C_v^{lit} and C_v^{bc} are presented elsewhere (Dhakal and others, 2010).

These values were determined for watersheds taken from a larger dataset accumulated by the researchers and used in a series of past TxDOT research projects (Asquith and others, 2004). The dataset comprised about 90 USGS streamflow-gaging stations located in the central part of Texas. The drainage area of study watersheds ranged from approximately 0.8–440.3 km² (0.3–170 mi²). The majority of the watersheds exceed the conventional limit of applicability for rational method application; however the method, being a subset of the unit hydrograph method was deemed suitable with some caveats. The rainfall-runoff dataset was comprised of about 1,600 rainfall-runoff events recorded during the period from 1959–1986. The number of events available for each watershed varied: for some watersheds only a few events were available whereas for some others as many as 50 events were available.

The cumulative frequency distributions of C_v^{lit} and C_v^{bc} developed for the study are shown on Figure 2.6. The dashed curve is the distribution of C_v^{lit} values. Of particular interest is that the distribution of C_v^{lit} is limited, ranging from 0.3–0.7. The distribution of C_v^{bc} values is depicted by the solid curve. Values of C_v^{bc} comprise the theoretical domain of 0.0–1.0. The median value for C_v^{lit} is 0.49; the median value of C_v^{bc} is 0.29. If the C_v^{bc} values are assumed to be representative of actual watershed behavior, then values of C_v^{lit} from the literature are about two times greater than they should be. While this finding alone is of interest, the bias in the results is of greater interest.

The peak discharges simulated for real storms were biased high towards the end of the distribution where the rational method would be anticipated to be valid, that is for the smaller watersheds — the fact that the bias is reduced for larger watersheds is suggestive that many tabulated runoff

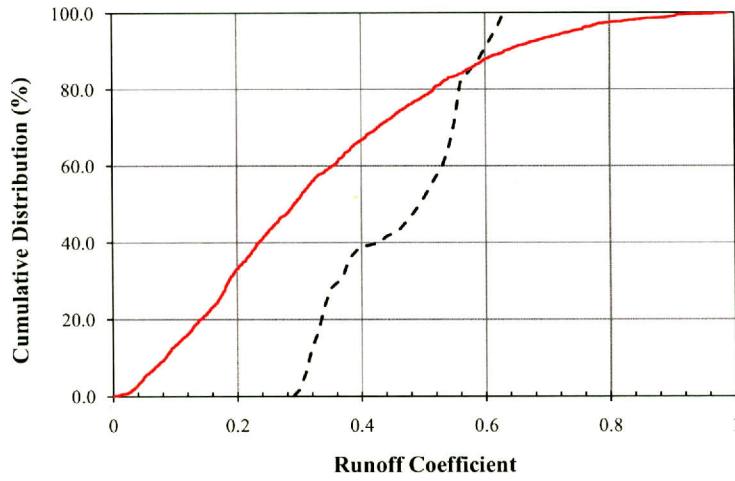

Figure 2.6: Cumulative distributions of the runoff coefficients C_v^{bc} (solid) and C_v^{lit} (dashed).

coefficients may indeed be volumetric based, but the researchers have no way to verify or refute this conjecture.

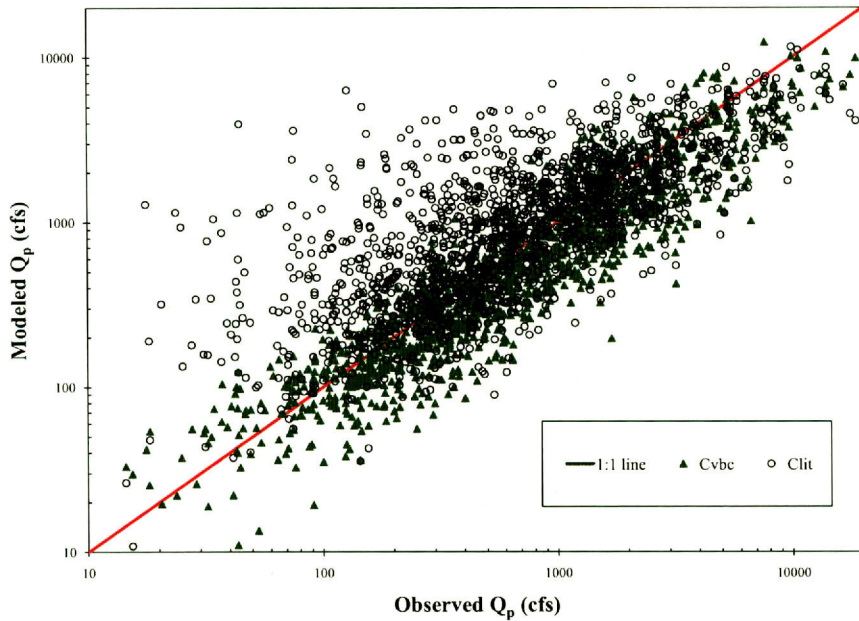

Figure 2.7: Modeled and observed peak discharge from C_v^{bc} (solid triangle) and C_v^{lit} (open circle) with timing parameters derived from the Kerby-Kirpich method.

Figure 2.7 is illustrative of the bias behavior. The solid triangle markers represent Q_p using the back-computed values of runoff coefficient — the volume match is forced, thus the runoff coefficient

in these cases strictly converts the incoming rainfall signal into excess rainfall. The open circle markers represent Q_p using the forward-specified literature values. The solid triangle marker cloud is uniformly distributed about the equal value line with no particular bias. The open circle marker cloud is taller on the left side than on the right, and biased high at least in the left two-thirds of the distribution — the portion that represents smaller watersheds.

2.2.2. Modified Rational Method Characteristic Time

As in the rational method, the watershed characteristic time is an exceedingly important value. The characteristic time in the MRM exercises great influence on the convolution integral (it establishes the kernel time window width). Because the MRM is designed to produce a hydrograph from either a uniform or non-uniform rainfall distribution, the characteristic time plays a less important role in the specification of rainfall intensity.

The time of concentration (the watershed characteristic time) was estimated for MRM application using the combination of the Kerby (1959) equation and the Kirpich (1940) equation as suggested in TxDOT research project 0–6496 (Roussel and others, 2005) for estimating the time of concentration on Texas watersheds.

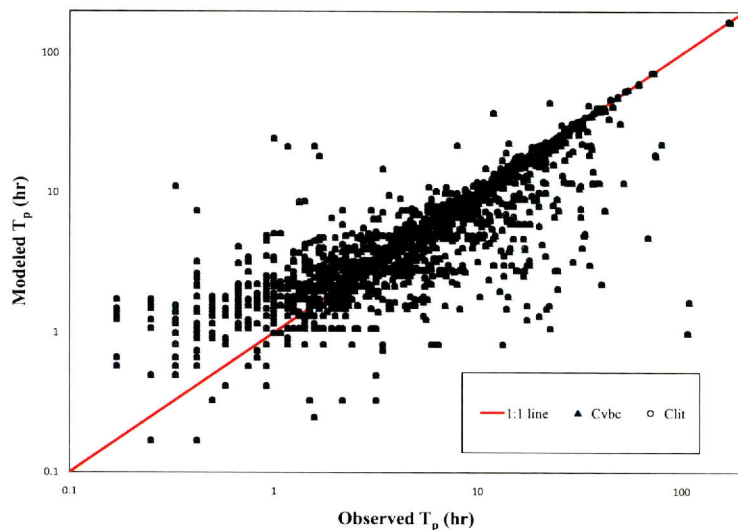

Figure 2.8: Modeled and observed time to peak from C_v^{bc} (blue) and C_v^{lit} (black) with timing parameters from the Kerby-Kirpich method.

Figure 2.8 is a plot of the time to peak using back-computed, C_v^{bc} and forward-computed runoff coefficients, C_v^{lit} . There is no difference between the times to peak using two different runoff coefficients, a consequence of T_p being entirely independent of the runoff generation process (in the unit hydrograph method).

2.2.3. Summary and Important Implications for the Modified Rational Method

Application of the modified rational method in practice requires specification of the watershed characteristic time, a feature shared by the rational method (and by all synthetic hydrologic methods). Conversion of rainfall into excess rainfall in the MRM is through application of the runoff coefficient. That is, excess rainfall (runoff) is a simple fraction of incoming rainfall. Therefore, the runoff coefficient used in the MRM is a volumetric runoff coefficient and represents a conceptual process substantially different from the rate-based runoff coefficient used for estimating only peak discharge via the conventional rational method.

The modified rational method, being a special case unit hydrograph, can be applied to non-uniform rainfall events and for watersheds with drainage areas which exceed that typically used for the rational method (a few hundred acres). The MRM performs about as well as other unit hydrograph methods, such as the gamma and Clark methods, in prediction of peak discharge of the direct runoff hydrograph when the same loss model is used to compute excess precipitation. Given that observation, the MRM is intended for use on the same watershed scale as the conventional rational method. Other than careful consideration of the value and meaning of the runoff coefficient, the MRM can likely be parameterized in the same fashion as the conventional rational method.

Issues associated with runoff coefficient specification, timing, and the implied probability matching of the runoff and runoff-generating precipitation are addressed in the following chapter. Material developed in the following chapter is specifically developed to be a substitute for the conventional rational method. However, material presented should behave favorably when used with the modified rational method. Based on MRM research, use of tabulated values, such as those presented in Appendix A and/or D, might result in overestimates of runoff volume in small systems, in part because of the fundamental change in the meaning of the runoff coefficient when applied in the MRM (in comparison to the meaning of the runoff coefficient when applied in the conventional rational method).

3. A PROPOSED UNIFIED RATIONAL METHOD FOR TEXAS

SOME RESEARCH CONTRIBUTIONS BY WILLIAM H. ASQUITH

Suggested Citation: Asquith, W.H., 2011, A proposed unified rational method for Texas *in* Cleveland, T.G., Fang, X., and Thompson, D.B., 2011, Use of the Rational and Modified Rational Methods for TxDOT Hydraulic Design: Texas Department of Transportation Research Report 0-6070-1, section 3, pp. 18-57.

The rational method for estimating peak streamflow “is a simple model to express a complex hydrologic system” (Viessman and Lewis, 1996). A unique rendition of the rational method to address small watershed flood hydrology throughout Texas, referred to as the “Unified Rational Method for Texas,” (URAT) is proposed in this section. The method was developed by the author with substantial contributions from the authors of this report (Cleveland, Fang, and Thompson). The method developed in this section is loosely dependent on results in Appendix C and mainly those results associated with the runoff coefficient; these dependencies are identified accordingly in this section.

The URAT for Texas is termed “unified” because the method combines: (1) a simplified specification of the runoff coefficient based on statistical analysis of observed rainfall intensities and associated peak streamflow for discrete storm events from small, undeveloped Texas watersheds; (2) the spatial interplay between statistically regionalized annual peak streamflow in Texas (Asquith and Roussel, 2009) and depth-duration frequency (DDF) of rainfall in Texas (Asquith and Roussel, 2004); (3) the general compatibility with Kuichling’s vision for the rational method (Kuichling, 1889), and (4) an explicit computational forcing of equivalency between frequency (recurrence interval) of peak streamflow and frequency of the rain event. The last component (frequency equivalence) is in strong contrast to the usual need to make assumptions of frequency equivalence—such assumptions are established practice in the hydrologic-engineering profession. Finally, the proposed method takes into account (1) the influence of annual recurrence interval, location in the state, drainage area, and main-channel slope on watershed time and (2) the amount of pervious and impervious parts of a watershed.

In the URAT for Texas, the runoff coefficient is denoted as C^* and watershed time as T^* . The T^* is by intent not conceptually associated with time-of-concentration T_c , as will become evident, but like T_c , the T^* will continue to represent a critical storm duration for the computation of average rainfall intensity. Values for C^* are determined uniquely by the fraction of impervious cover in the

watershed. Systematic tuning of the URAT method to generalized flood hydrology in Texas is made solely through T^* . This tuning is in the form of a regression equation with coefficient lookup tables that account for annual recurrence interval F , spatial location (by county), drainage area A , and dimensionless main-channel slope S . For URAT, the intensity-duration frequency (IDF) of rainfall I^* is computed from the depth-duration frequency (DDF) of rainfall $D(T^*, F)$ by $D(T^*, F)/T^*$. The $D(T^*, F)$ are estimated from Asquith and Roussel (2004). The Asquith and Roussel (2004) atlas is a complete source for the DDF of rainfall in Texas for storm durations suitable in the application of any rational method manifestation inclusive of URAT. The peak streamflow Q^* in cubic feet per second for URAT is in the form of the usual rational method and computed by

$$Q^* = 1.008 C^* I^* A, \quad (3.1)$$

where 1.008 is a usually ignored unit conversion factor but retained in the computational algorithms used here, C^* is the runoff coefficient (dimensionless), I^* is design rainfall intensity in inches per hour, and A is drainage area in acres. Methods to estimate C^* and T^* are formally described in sections that follow and example computations are provided.

3.1. Runoff Coefficient for the Unified Rational Method for Texas

The “base-runoff coefficient” C_b for pervious surfaces ranges from about 0.15 to 0.20 with a median of about 0.17. The C_b range is based on generalization of C_R values of runoff coefficient described in Appendix C. The C_R are rate-based, back-computed runoff coefficients of the rational method with a specific definition of critical storm duration and are derived from about 80 undeveloped to slightly developed small watersheds in Texas. The C_b value range is consistent with a $C = 0.15$ used by Kuichling (1889, p. 42) more than 120 years ago. Kuichling also considered the fraction of impervious cover in the watershed. Therefore, in the absence of watershed-specific data, the author suggests that the expression of the runoff coefficient of URAT for Texas (C^*) be prorated by impervious area and expressed as

$$C^* = IMP \times C_{\text{imp}} + (1 - IMP) \times C_b, \quad (3.2)$$

where IMP is impervious cover as a fraction of watershed area. For URAT, it is suggested for general application that $C_{\text{imp}} = 1$, where C_{imp} is the “impervious-runoff coefficient.” Upon substitution of $C_b = 0.15$ and $C_{\text{imp}} = 1$, the equation yields

$$C^* = 0.85 \times IMP + 0.15. \quad (3.3)$$

In URAT, C^* is assumed to be independent of rainfall intensity as rainfall intensity is affected by F and county. Also, C^* is not affected by A and S . The factors F , county, A , and S are important components in the T^* of URAT. The factor F is storm frequency expressed in conventional notation for nonexceedance probabilities but also used interchangeably with recurrence intervals to maintain consistent terminology with Asquith and Roussel (2004) and Asquith and Roussel (2009).

Eq. 3.3 produces C^* values that are reasonably consistent with established tables of the runoff coefficient C of the rational method for undeveloped watersheds. For example, $C_b = 0.15$ is consistent

with the middle of the C -value ranges (Viessman and Lewis, 1996, p. 313) suitable for 5- to 10-year annual recurrence interval for watersheds described by Viessman and Lewis as *parks, cemeteries, unimproved areas, lawns or sandy soil with average slope (2–7 percent), lawns or sandy soil with steep slope (7 percent), and lawns or heavy soil with flat slope (2 percent)*. As further justification of C^* , consider eq. 3.4 by Schaake and others (1967, p. 367):

$$C^{[5]} = 0.14 + 0.65 \times IMP + 5 \times S^\dagger \quad (3.4)$$

where $C^{[5]}$ is the runoff coefficient for the 5-year recurrence interval, IMP is impervious cover, and S^\dagger is the dimensionless slope of the main channel. The author acknowledges that eq. 3.4 for C is a regression equation, in contrast to the largely heuristic method for C^* presented here.

The C^* values are constrained by the interval 0.15 to 1. The lower limit is reasonably consistent with the highly pervious or flood water retaining surfaces in the literature. The upper limit of this interval is consistent with the steady-state idealization of the rational method in that the inequality $C \leq 1$ must hold. Further, C^* are not derived from volumetric analysis of rainfall and runoff totals (volumes) but are derived from conceptualization of the runoff coefficient C as a constant of rate proportionality.

Although additional refinement of the C^* might be possible, such as the inclusion of annual recurrence interval, the author suggests that tuning to the effect of watershed time on the rational method computations is preferable. The suggestion is reasonable because, as described by Hayes and Young (2005, p. 9) “The runoff coefficient and time of concentration are controlled by some of the same storm and basin characteristics, and therefore, are not independent.” The C can not be decoupled from T_c in the same way that C^* can not be decoupled from T^* , and refinement of time after locking down (fixing) C is the author’s preference. This preference is made because time is an identifiable and semi-measurable characteristic of a watershed. Further, the preference is made because $T_c > 0$ and therefore is conceptually unconstrained by an upper limit—unlike the upper bounds of C . At this point, the concept of T_c is dropped and replaced entirely with a concept of “watershed time of equivalence” and denoted as T^* for the critical storm duration.

Rational method applications require IDF, which can be derived from DDF in Asquith and Roussel (2004). Conversely, Asquith and Roussel (2009, table 3) provide statewide equations for estimation of peak streamflow for selected annual recurrence intervals for undeveloped watersheds—those watersheds with effectively zero impervious cover and unregulated flood flow in Texas. The equations are based on analysis of observed peak streamflow, are independent of IDF/DDF relations, and are dependent on a spatially distributed parameter known as OmegaEM (Asquith and Roussel, 2009, see figs. 3–5). The DDF values and peak-streamflow equations (the OmegaEM equations) provide a means to develop estimates for watershed time T^* under the assumption that eq. 3.3 is correct for $IMP = 0$.

To further refine or correct T^* for each of 254 counties in Texas and for selected annual recurrence intervals, a complex analysis (briefly summarized here) was conducted. The description of the analysis implies familiarity with Asquith and Roussel (2004) and Asquith and Roussel (2009). The highly-specialized, single-purpose computer algorithms used are contained in Appendix C.2. Succinctly, the following procedure was followed to derive T^* :

1. The OmegaEM parameter of Asquith and Roussel (2009) was determined for the center of each county in Texas by bi-linear interpolation of the 1-degree latitude and longitude OmegaEM maps (the values OmegaEM are listed in table 3.1, which is located at the end of Section 3 and starting on page 30);
2. The mean annual precipitation P in inches by county in Texas was provided by Donnie L. Brooks (USGS, written commun., 2010) obtained from the PRISM Climate Group (Oregon State University, 2010) web application using 1961–90 climatological data for the approximate center of each county. For the URAT method, any authoritative source of P would be appropriate for application (the values P are listed in table 3.1, which is located at the end of Section 3 and starting on page 30);)
3. The 2-, 5-, 10-, 25-, 50-, and 100-year depths of rainfall for durations of 15 and 30 minutes and 1, 2, 3, 6, and 12 hours from Asquith and Roussel (2004) for the center of each county in Texas were determined from digital files processed by Lucia Barbato (Texas Tech University, written commun., 2005);
4. A sequence (vector) of drainage area A values from 10 to 10,000 acres by half-log cycles was created. (The mean of the sequence is about 2,090 acres.) This sequence was used to numerically assess the interplay between peak-streamflow estimates from Asquith and Roussel (2009) and IDF/DDF estimates from Asquith and Roussel (2004);
5. A sequence (vector) of dimensionless main-channel slope S values from 0.1 to 10 percent by half-log cycles was created. (The mean of the sequence is about 2.9 percent.) This sequence also was used to numerically assess the interplay between peak-streamflow estimates from Asquith and Roussel (2009) and IDF/DDF estimates from Asquith and Roussel (2004);
6. For each recurrence interval and each county, using OmegaEM and P for each county and using each unique pairing of the sequences of A and S , peak-streamflow values from the “OmegaEM equations” in Asquith and Roussel (2009, table 3) were computed and are referred to as the “OmegaEM Q ” values;
7. For each recurrence interval and each county, vectors of A and OmegaEM Q were used to compute \tilde{I} or “rainfall intensities of equivalence” by $\tilde{I} = Q/(1.008 C^* A)$ or $\tilde{I} = 6.6Q/A$ where $C^* = 0.15$ (eq. 3.3) and $IMP = 0$;
8. For each \tilde{I} , and using log-log linear interpolation (or extrapolation to as small as 0.6 minutes or to as large as 18 hours) of the IDF relation for each county and recurrence interval, the times corresponding to the intensities were computed and visualized. These times are jointly referred to as “watershed times of equivalence” and denoted as T^* ;
9. The T^* are recurrence interval dependent and also scale with (are dependent on) A and S because of the interplay of A and S within step 6 and the physical manifestation of travel time with watershed size and inclination (slope). For each county and recurrence interval, an ordinary least-squares regression between the base-10 logarithms of runoff coefficients of equality and base-10 logarithms of S was computed and visualized. A total of 1,524 regressions (6 recurrence intervals \times 254 counties) thus were computed; and finally

10. The intercepts of β and exponents on A and S of the equations by recurrence interval were tabulated by county and are listed in tables 3.2, 3.3, and 3.4, respectively (located at end of Section 3 and starting on page 34). The 1,524 β values are listed (table 3.2) after 10^B conversion, and the 1,524 S -exponent values were multiplied by -1 (table 3.4).

The enumerated steps produce the equation ensemble for T^* . The equations show that the effects of recurrence interval on time are contained in the three regression coefficients and are spatially dependent. The representation of the time ensemble by county and by recurrence interval is:

$$T_{\text{county}}^{*[\cdot]} = \begin{cases} \beta_2 A^{\alpha_2} S^{-\kappa_2} & \text{for 2-year recurrence interval} \\ \beta_5 A^{\alpha_5} S^{-\kappa_5} & \text{for 5-year recurrence interval} \\ \beta_{10} A^{\alpha_{10}} S^{-\kappa_{10}} & \text{for 10-year recurrence interval} \\ \beta_{25} A^{\alpha_{25}} S^{-\kappa_{25}} & \text{for 25-year recurrence interval} \\ \beta_{50} A^{\alpha_{50}} S^{-\kappa_{50}} & \text{for 50-year recurrence interval} \\ \beta_{100} A^{\alpha_{100}} S^{-\kappa_{100}} & \text{for 100-year recurrence interval} \end{cases} \quad (3.5)$$

where $T_{\text{county}}^{*[\cdot]}$ is in minutes for an optionally identified annual recurrence interval shown by $[\cdot]$, A is drainage area in acres, and S is dimensionless main-channel slope. The regression coefficients β , α , and κ are listed in tables 3.2, 3.3, and 3.4, respectively. The subscripts (2, 5, 10, 25, 50, and 100) represent annual recurrence interval. The values listed in table 3.2 are multiplied by 60 to yield a time estimate in minutes for eq. 3.5 (the source algorithms used hours). The values listed in table 3.4 are negated; therefore multiplication by -1 (re-negation) is shown in eq. 3.5. (The negation was made to avoid using the “ $-$ ” sign in table 3.4.)

Graphical depiction of the β_T , α_T , and κ_T values is shown in figures 3.1, 3.2, and 3.3, respectively (located at end of Section 3 and starting on page 55). The figures show that systematic spatial variation in the coefficients for T^* estimation exists. Precise interpretation of the magnitudes and patterns is difficult to provide. However and in particular, the systematic variation of the α_T , and κ_T shown in figures 3.2 and 3.3 emphasizes the semi-independent interplay between the DDF, P , and OmegaEM across the state.

Finally, an expression for a statewide T^* generalization based on the median values¹ of the by-county regression coefficients is:

$$T_{\text{TEXAS}}^* = \begin{cases} 0.228 A^{0.519} S^{-0.430} & \text{for 2-year recurrence interval} \\ 0.113 A^{0.384} S^{-0.628} & \text{for 5-year recurrence interval} \\ 0.099 A^{0.315} S^{-0.693} & \text{for 10-year recurrence interval} \\ 0.104 A^{0.218} S^{-0.757} & \text{for 25-year recurrence interval} \\ 0.137 A^{0.150} S^{-0.780} & \text{for 50-year recurrence interval} \\ 0.150 A^{0.095} S^{-0.837} & \text{for 100-year recurrence interval} \end{cases} \quad (3.6)$$

where T_{TEXAS}^* is in minutes, A is drainage area in acres, and S is dimensionless main-channel slope. These equations are intended for generalized description of watershed time or critical storm duration for comparison to county-specific values.

¹The sample size for each median computation is 254 because there are 254 counties in Texas.

3.2. Example Computations and Discussion for Unified Rational Method for Texas

Several example computations are provided in this section to communicate a perspective on potential results as well as a springboard for additional discussion concerning interpretation of URAT results.

3.2.1. Statewide Watershed Time of Equivalence in Texas

The statewide T_{TEXAS}^* are used in this section for illustration, but the discussion can be generalized for other T_{county}^* . Suppose that a watershed has $A = 3$ acres and $S = 0.006$, time for the 2-year annual recurrence interval is $T_{\text{TEXAS}}^{*[2]} = 0.228 \times (3)^{0.519} \times (0.006)^{-0.430} = 3.6$ minutes and the time for the 100-year annual recurrence interval is $T_{\text{TEXAS}}^{*[100]} = 0.150 \times (3)^{0.095} \times (0.006)^{-0.837} = 12$ minutes when rounded to the nearest minute. A potentially confusing fact is that the T_{TEXAS}^* equations estimate *longer* watershed time as recurrence interval increases. (Such a situation might also occur for some counties and certain combinations of A and S .) This observation is at first counter intuitive because the expectation is that watersheds respond faster as rainfall intensity increases. The author explicitly acknowledges that such inversion of expectation of time and recurrence interval will be of concern to the hydrologic-engineering community. Mitigation for circumstances in which time contracts with increasing recurrence interval is suggested as part of general URAT implementation.

The author stresses that T^* is a time-of-equivalence and should not be strictly interpreted as a watershed response time in the way that time concepts such as T_c or time-to-peak are interpreted. However, T^* should be on the same order as watershed response times. The T^* are mostly interpreted as critical storm durations that force statistical congruence of Asquith and Roussel (2004) and Asquith and Roussel (2009) as manifested through the mathematical form of the rational equation. The increasing time with annual recurrence interval in these computations, which has the general effect of relative lowering of rainfall intensity, indicates that the peak-streamflow increase with recurrence interval that is predicted by the peak-streamflow equations is lower than seen for the IDF for a fixed duration.

Although the preceding example using a 3-acre watershed resulted in $T_{\text{TEXAS}}^* = 3.6$ minutes for a 2-year recurrence interval, the author suggests that T^* values for URAT are to be truncated to 10 minutes or longer. A benefit of this suggestion is that estimation of IDF for less than 10 minutes is a problematic extrapolation because the shortest analyzed duration in Asquith and Roussel (2004) is 15 minutes. The extrapolation from 15 minutes to less than 10 minutes thought by the author (as investigator of record for URAT and (Asquith and Roussel, 2004)) to be unreliable for design purposes. The TxDOT hydraulic-design manual (Texas Department of Transportation, 2009, p. 5-21 (item 5)) calls for a minimum time of 10 minutes for the T_c (the analog of T^*) in design computations.

Limits of the Unified Rational Method for Texas

There are several major conceptual limits to URAT. First, as identified in the previous paragraph, $T^* < 10$ minutes is to be truncated at 10 minutes; the equivalent drainage area for such a time is difficult to express because of interplay between predictive variables on T^* . Second, an upper limit of T^* also is difficult to identify. Third, from Appendix C, the author interprets the general time-area linearity in figure C.5 and the runoff coefficient-area relation in figure C.6 to indicate that the rational method might be suitable for larger upper limits of drainage area than often used. The hydrologic-engineering community often uses upper limits for the rational method at a quarter to half a square mile. The computational elements producing the URAT provide no additional insight into what the upper drainage area limit should be. In practice, the steady-state assumption of the watershed for the rational method and anticipated importance of routing and storage are keys to guiding the engineer in judging applicability of URAT (and other forms of the rational method).

3.2.2. Spatial Influence on 10-year T-star

The statewide equations in eq. 3.6 for Texas do not accommodate the substantial changes in flood hydrology across Texas. In an effort to accommodate spatial differences in flood hydrology across Texas, URAT takes into account the influence of spatial location by county. The influence of spatial location manifests in the development of T^* through P , OmegaEM, and county-specific IDF curves. This spatial influence is represented in URAT by the regression coefficients by county in tables 3.2–3.4.

To provide example computations concerning influence of location in Texas, suppose that six 640-acre watersheds with half-percent slopes exist in Brewster (far-west Texas), Brooks (south Texas), Borden (southern Texas Panhandle), Baylor (north-central Texas), Blanco (central Texas), and Bowie (northeast Texas) counties. What are the estimated values of watershed time or storm duration using T_{TEXAS}^* and T_{county}^* for the 10-year annual recurrence interval for each of these counties? The statewide estimated value is

$$T_{\text{TEXAS}}^{*[10]} = 0.099 \times 640^{0.315} \times 0.005^{-0.693} = 30 \text{ minutes}, \quad (3.7)$$

and the individual county values are

$$\begin{aligned} T_{\text{Brewster}}^{*[10]} &= 2.822 \times 640^{0.218} \times 0.005^{-0.488} = 153 \text{ minutes}, \\ T_{\text{Brooks}}^{*[10]} &= 0.496 \times 640^{0.308} \times 0.005^{-0.655} = 117 \text{ minutes}, \\ T_{\text{Borden}}^{*[10]} &= 0.384 \times 640^{0.287} \times 0.005^{-0.657} = 80 \text{ minutes}, \\ T_{\text{Baylor}}^{*[10]} &= 0.084 \times 640^{0.336} \times 0.005^{-0.751} = 39 \text{ minutes}, \\ T_{\text{Blanco}}^{*[10]} &= 0.070 \times 640^{0.318} \times 0.005^{-0.694} = 22 \text{ minutes, and} \\ T_{\text{Bowie}}^{*[10]} &= 0.052 \times 640^{0.317} \times 0.005^{-0.700} = 16 \text{ minutes.} \end{aligned}$$

These times vary greatly; relative to the the statewide estimate, the time for Bowie county is about half and the time for Brewster county is about 5 times longer. How can these times be interpreted? As the general aridity of the county increases (consider arid Brewster county compared to humid Bowie county), the effective rainfall duration increases substantially. The author suggests that this is attributed in part to the generally lower antecedent moisture conditions and higher initial abstraction potential in the semi-arid to arid counties of central to western Texas. Longer duration rainfall (and hence more total rainfall depth for flood-producing rainfall) is generally required to initially saturate soil and fill depressions of the surface of watersheds in western Texas compared to watersheds in other parts of the State. General hydrologic knowledge of Texas indicates that the thin soils and limestone geologic setting of Blanco county would result in some of the smallest watershed times in Texas—the previous computations show this to be the case.

3.2.3. Relative Influence of Recurrence Interval on T-star for Two Low-Slope Settings

An S of 0.002 is representative of a low-slope setting. A comparison of T^* results for the essentially flat (low-slope topography) of Harris and Lubbock counties in Texas is made. For Harris county, the time ensemble of URAT for a 200-acre watershed is

$$\begin{aligned}
 T_{\text{Harris}}^{*[2]} &= 0.135 \times 200^{0.542} \times 0.002^{-0.445} = 38 \text{ minutes,} \\
 T_{\text{Harris}}^{*[5]} &= 0.068 \times 200^{0.405} \times 0.002^{-0.665} = 36 \text{ minutes,} \\
 T_{\text{Harris}}^{*[10]} &= 0.074 \times 200^{0.326} \times 0.002^{-0.715} = 35 \text{ minutes,} \\
 T_{\text{Harris}}^{*[25]} &= 0.075 \times 200^{0.229} \times 0.002^{-0.807} = 38 \text{ minutes,} \\
 T_{\text{Harris}}^{*[50]} &= 0.068 \times 200^{0.169} \times 0.002^{-0.882} = 40 \text{ minutes, and} \\
 T_{\text{Harris}}^{*[100]} &= 0.090 \times 200^{0.102} \times 0.002^{-0.907} = 43 \text{ minutes.}
 \end{aligned}$$

and for Lubbock county, the time ensemble is

$$\begin{aligned}
 T_{\text{Lubbock}}^{*[2]} &= 0.885 \times 200^{0.449} \times 0.002^{-0.400} = 115 \text{ minutes,} \\
 T_{\text{Lubbock}}^{*[5]} &= 0.505 \times 200^{0.347} \times 0.002^{-0.571} = 110 \text{ minutes,} \\
 T_{\text{Lubbock}}^{*[10]} &= 0.378 \times 200^{0.292} \times 0.002^{-0.658} = 106 \text{ minutes,} \\
 T_{\text{Lubbock}}^{*[25]} &= 0.402 \times 200^{0.203} \times 0.002^{-0.737} = 115 \text{ minutes,} \\
 T_{\text{Lubbock}}^{*[50]} &= 0.411 \times 200^{0.148} \times 0.002^{-0.789} = 121 \text{ minutes, and} \\
 T_{\text{Lubbock}}^{*[100]} &= 0.395 \times 200^{0.092} \times 0.002^{-0.853} = 129 \text{ minutes.}
 \end{aligned}$$

For the time ensembles T^* for Harris and Lubbock counties, the computations show a non-monotonic pattern of time. This non-monotonicity is important and is extensively considered in later discussion. For now, it is observed that watershed times of equivalence T^* in Harris (Houston area) are systematically about 33 percent less than the times for Lubbock county. Although direct interpretation of

T^* as a “travel time” is tenuous, the shorter time in Harris county relative to Lubbock county is entirely consistent with several watershed characteristics. Harris county is located on the Texas coast with substantially larger IDF and P and in an area for which watersheds need to be considered as typically having higher antecedent moisture conditions compared to those in Lubbock county. These characteristics suggest that the rainfall-runoff conversion process is more efficient (or more recurrent) in Harris county compared to Lubbock county and thus larger peak discharges are expected (because in part of much shorter T^*) even though the undeveloped runoff coefficient of the URAT is $C^* = 0.15$ for both counties.

3.2.4. Comparison of Unified Rational Method for Houston Metropolitan Area (Harris County) to Harris County Flood Control District Site-Runoff Curves

The Harris County Flood Control District “Site-Runoff Curves” are used (Storey and others, 2004, p. 3-3) “to determine peak flows for: onsite detention facilities, overland flow[s] (extreme event[s]), storm sewer systems or overland swales [intended to accommodate] the overland flow[s], and closed conduits.” It is difficult to compare URAT to the Harris County Flood Control District (HCFCD) “site-runoff curves” (Storey and others, 2004, p. 3-3 and 3-4) because the curves do not explicitly utilize watershed slope. However, for a comparison of sorts, an equivalent slope can be back computed by starting with solutions for a 200-acre watershed from the HCFCD site curves for the 10-year recurrence interval with zero impervious cover ($C^* = 0.85 \times 0 + 0.15 = 0.15$) is $Q_{10} = 2.1(200)^{0.823} = 164$ cubic feet per second and with 85 percent impervious cover is $Q_{10} = 5.9(200)^{0.823} = 462$ cubic feet per second. Solving the IDF relation² for Harris county within URAT for $Q = 164$ cubic feet per second with zero impervious cover ($C^* = 0.85 \times 0.85 + 0.15 = 0.873$), results in $T^{*[10]} = 19$ minutes; solving for S in $19 = 0.075 \times 200^{0.326} S^{-0.715}$ yields $S = 0.0049$. Again solving the IDF relation³ for Harris county within URAT for $Q = 462$ cubic feet per second with 85 percent impervious cover, one determines that $T^{*[10]} = 70$ minutes, which solving for S by $70 = .075 \times 200^{0.326} S^{-0.715}$ yields $S = 0.0008$. Both slope values are representative of low-slope topography, which is consistent with the general low-slope conditions of the Houston metropolitan area for which the site-runoff curves were developed.

3.2.5. Using the Unified Rational Method for Computation of Peak-Streamflow Frequency

The following example illustrates implementation of URAT. Suppose that a watershed in Dickens county has $C^* = 0.15$, $A = 40$ acres, $S = 0.001$, $P = 22$ inches, and $\text{OmegaEM} = -0.088$ (the values for P and OmegaEM are from table 3.1, which is located at the end of Section 3 and starting on page 30). How do the OmegaEM Q values from Asquith and Roussel (2009) compare to the Q

²The applicable 10-year recurrence interval intensities are 6.20 and 4.20 inches per hour for respective durations of 15 and 30 minutes. Log-log linear interpolation using an intensity $I^* = 164/(0.15 \times 200) = 5.47$ inches per hour will yield a duration of $T^* = 19$ minutes.

³The applicable 10-year recurrence interval intensities are 2.90 and 1.93 inches per hour for respective durations of 1 and 2 hours. Log-log linear interpolation using an intensity $I^* = 463/(0.873 \times 200) = 2.65$ inches per hour will yield a duration of $T^* = 70$ minutes.

values computed from the URAT? Solving for OmegaEM Q produces 7.30, 8.34, 9.70, 10.2, 10.5, and 10.9 cubic feet per second for the recurrence intervals of 2, 5, 10, 25, 50, and 100 years, respectively. Solving for the T^* for Dickens county from tables 3.2, 3.3, and 3.4 produces

$$\begin{aligned}
 T_{\text{Dickens}}^{*[2]} &= 0.739 \times 40^{0.463} \times 0.001^{-0.385} = 58 \text{ minutes,} \\
 T_{\text{Dickens}}^{*[5]} &= 0.368 \times 40^{0.361} \times 0.001^{-0.583} = 78 \text{ minutes,} \\
 T_{\text{Dickens}}^{*[10]} &= 0.246 \times 40^{0.314} \times 0.001^{-0.674} = 82 \text{ minutes,} \\
 T_{\text{Dickens}}^{*[25]} &= 0.230 \times 40^{0.218} \times 0.001^{-0.786} = 117 \text{ minutes,} \\
 T_{\text{Dickens}}^{*[50]} &= 0.208 \times 40^{0.160} \times 0.001^{-0.862} = 145 \text{ minutes, and} \\
 T_{\text{Dickens}}^{*[100]} &= 0.150 \times 40^{0.098} \times 0.001^{-0.984} = 193 \text{ minutes.}
 \end{aligned}$$

and these durations are used to compute I^* by recurrence interval from Asquith and Roussel (2004). The values I^* are 1.40, 1.82, 1.70, 1.66, 1.65, and 1.54 inches per hour for the 2-, 5-, 10-, 25-, 50-, and 100-year recurrence interval, respectively. The resulting Q from URAT are thus

$$\begin{aligned}
 Q_{\text{Dickens}}^{*[2]} &= 1.008 \times 0.15 \times 1.40 \times 40 = 8.47 \text{ cubic feet per second,} \\
 Q_{\text{Dickens}}^{*[5]} &= 1.008 \times 0.15 \times 1.82 \times 40 = 10.9 \text{ cubic feet per second,} \\
 Q_{\text{Dickens}}^{*[10]} &= 1.008 \times 0.15 \times 1.70 \times 40 = 10.2 \text{ cubic feet per second,} \\
 Q_{\text{Dickens}}^{*[25]} &= 1.008 \times 0.15 \times 1.66 \times 40 = 9.96 \text{ cubic feet per second,} \\
 Q_{\text{Dickens}}^{*[50]} &= 1.008 \times 0.15 \times 1.65 \times 40 = 9.98 \text{ cubic feet per second, and} \\
 Q_{\text{Dickens}}^{*[100]} &= 1.008 \times 0.15 \times 1.54 \times 40 = 9.24 \text{ cubic feet per second.}
 \end{aligned}$$

These values are not monotonically increasing, which is a physical requirement. The cause is the complex interplay of the relative growth by recurrence interval of OmegaEM Q and D and the coupling of the watershed time of equivalence along with other sources of uncertainty. A somewhat similar condition is recognized in Asquith and Slade (1997, p. 11) in context of peak-streamflow equations prior to those in Asquith and Roussel (2009) and mitigation for non-monotonicity is needed as part of the design process. Such mitigation is a necessary component to implement URAT of Texas.

The following procedure is suggested to ensure monotonicity of Q^* ; the procedure also results in an expression of Q^* uncertainty by computation of lower and upper bounds.

1. Sort the T^* values in ascending order; however, for the example, this step is not necessary;
2. Determine a T_L^* ("lower T-star") by computing the mean of the two shortest T^* ; for the example, $T_L^* = (58 + 78)/2 = 68$ minutes;
3. Determine a \bar{T}^* ("bar T-star") by computing the mean of the two middle T^* ; for the example, $\bar{T}^* = (82 + 117)/2 = 100$ minutes;
4. Determine a T_U^* ("upper T-star") by computing the mean of the two longest T^* ; for the example, $T_U^* = (145 + 193)/2 = 169$ minutes;

5. Determine I_U^* using T_L^* by recurrence interval from Asquith and Roussel (2004); for the example, I_U^* is 1.17, 1.61, 1.94, 2.39, 2.79, and 3.22 inches per hour for the respective recurrence intervals of 2, 5, 10, 25, 50, and 100 years. (These rainfall intensities will result in the largest discharges of URAT, and note that the I_U^* and T_L^* nomenclature is correct.)
6. Determine \bar{T}^* using \bar{T}^* by recurrence interval from Asquith and Roussel (2004); for the example, \bar{T}^* is 0.88, 1.23, 1.47, 1.85, 2.18, and 2.54 inches per hour for the respective recurrence intervals of 2, 5, 10, 25, 50, and 100 years.
7. Determine I_L^* using T_U^* by recurrence interval from Asquith and Roussel (2004); for the example, I_L^* is 0.56, 0.81, 0.97, 1.23, 1.45, and 1.71 inches per hour for the respective recurrence intervals of 2, 5, 10, 25, 50, and 100 years. (These rainfall intensities will result in the smallest discharges of URAT, and note that the I_L^* and T_U^* nomenclature is correct.)
8. Compute Q_U^* by rational method equation using C^* and I_U^* ; for the example, Q_U^* is 7.08, 9.74, 11.7, 14.5, 16.9, and 19.5 cubic feet per second;
9. Compute \bar{Q}^* by rational method equation using C^* and \bar{T}^* ; for the example, \bar{Q}^* is 5.32, 7.44, 8.89, 11.2, 13.2, and 15.4 cubic feet per second;
10. Compute Q_L^* by rational method equation using C^* and I_L^* ; for the example, Q_L^* is 3.39, 4.90, 5.87, 7.44, 8.77, 10.3 cubic feet per second;
11. Plot the three curves of Q_U^* , \bar{Q}^* , and Q_L^* as shown in figure 3.4 (located at the end of Section 3 on page 58) and declare \bar{Q}^* as the best estimate and Q_U^* and Q_L^* as respective upper and lower bounds.

The values for Q_L^* , \bar{Q}^* , and Q_U^* along with the OmegaEM Q estimates are listed in table 3.5 (located at the end of Section 3 on page 54). The table shows, for this county and watershed characteristics, streamflow compatibility between the two methods as expected.

The example is now extended. Suppose the watershed is to be developed with 53-percent impervious cover. The $C^* = 0.85 \times 0.53 + 0.15$ is $C^* = 0.60$. The $Q_{\text{Dickens}}^{*[100]}$ for $C^* = 0.60$ conditions is about 44 cubic feet per second $[(0.60/0.15) \times 10.9]$. The quantity $0.60/0.15 = 4$ is independent of annual recurrence interval. Therefore, the estimated peak streamflows for a development with 53-percent impervious cover is 4 times larger than the values listed in column 4 of table 3.5.

The previous computations show that URAT strictly handles watershed development by impervious cover and does not accommodate contraction in watershed time attributable to enhanced flow efficiency by development features such as curb and gutters and drainage inlets, channels, and conduits—this is a valid criticism of URAT. Another criticism of URAT is that development is treated the same throughout Texas. However, the author recognizes that watershed development is only partially accommodated by impervious cover in URAT and for a given fraction of impervious development practices (designs) and concomitant watershed response to rainfall can differ substantially between municipalities across Texas.

3.2.6. Computation of Upper Bound of Streamflow Estimates

The C^* values for undeveloped $IMP = 0$ to fully developed $IMP = 1$ (100-percent impervious cover) are 0.15 and 1, respectively. The ratio $1/0.15 = 6.67$, which means that the upper limit of C^* for developed watersheds is about $6\frac{2}{3}$ larger than undeveloped watersheds. Because the ratio can be expressed as the integer ratio $20/3$, the author suggests that the upper-bound streamflow estimate of URAT be referred to as the “twenty-thirds rule.” However, C^* is not dependent on other development conditions such as curb and gutter sections and other flow-concentrating features that are known to generally contract watershed response time and increase peak discharge. This observation is accommodated by a specific suggestion that the twenty-thirds rule be thought of as the lower-support of an unknown upper-bound multiplier or “on the low end of the range of the unknown multiplier” for fully developed watersheds that lack storm-water retention systems. (Retention systems, such as storm-water retention ponds, are likely to weaken the assumption of steady-state watershed conditions needed to justify the application of the rational method.)

3.3. Summary of a Proposed Unified Rational Method for Texas

The proposed Unified Rational Method (URAT) for Texas represents a unique rendition of the venerable rational method with detailed adjustments for each of 254 counties in the State for selected annual recurrence intervals of 2, 5, 10, 25, 50, and 100 years. URAT was developed by the author with substantial contributions from the authors of this report (Cleveland, Fang, and Thompson). The runoff coefficient C^* for URAT is largely based on heuristic arguments and includes the generalized effects of impervious cover on peak streamflow. URAT yields runoff coefficients that are consistent with those originally proposed by Kuichling (1889), individual storm analysis using Texas data, and other values seen elsewhere in the literature. The watershed time T^* of URAT is known as a watershed time-of-equivalence and serves as the critical storm duration. The T^* is founded on statistical congruence by-county between depth-duration frequency of rainfall for Texas by Asquith and Roussel (2004) and regionalized peak-streamflow estimates for Texas by Asquith and Roussel (2009) using the OmegaEM equations. Intensity-duration frequency of rainfall (IDF) for URAT from Asquith and Roussel (2004) is suggested for URAT; however, other sources of IDF are expected to be applicable. Regression equations developed for URAT to estimate T^* use drainage area A in acres and dimensionless main-channel slope S and are tabulated by county and annual recurrence interval. In practice, URAT is not expected to produce peak streamflows by recurrence interval equal to those from equations in Asquith and Roussel (2009), but users might be assured that the two methods (URAT and OmegaEM equations) should provide compatible and semi-independent estimates of peak-streamflow frequency for undeveloped watersheds in Texas. Unlike the methods of Asquith and Roussel (2009), URAT extends peak streamflow estimation from undeveloped to developed watersheds. Also, the URAT implementation as suggested here includes the capacity for an estimated lower and upper bounds of peak streamflow. The twenty-thirds rule of URAT indicates that the lower-support of an unknown upper-bound multiplier of undeveloped peak streamflow to adjust for fully developed conditions as represented by impervious cover is about 6.7 times larger than that for zero-impervious cover conditions.

Table 3.1: Countywide values of mean-annual precipitation and OmegaEM parameter.

| County name | Mean-annual precipitation (inches) | OmegaEM (dimensionless) | County name | Mean-annual precipitation (inches) | OmegaEM (dimensionless) |
|-------------|------------------------------------|-------------------------|-------------|------------------------------------|-------------------------|
| Anderson | 41 | -0.045 | Karnes | 31 | 0.083 |
| Andrews | 15 | -.133 | Kaufman | 40 | .105 |
| Angelina | 47 | -.144 | Kendall | 32.6 | .194 |
| Aransas | 36 | .088 | Kenedy | 27 | -.176 |
| Archer | 28 | .015 | Kent | 21.7 | -.087 |
| Armstrong | 20 | -.101 | Kerr | 29 | .31 |
| Atascosa | 27 | -.091 | Kimble | 26 | .312 |
| Austin | 41 | .054 | King | 24 | -.063 |
| Bailey | 18 | -.139 | Kinney | 23 | .238 |
| Bandera | 31 | .293 | Kleberg | 29 | -.116 |
| Bastrop | 36 | .121 | Knox | 26 | -.025 |
| Baylor | 26.5 | 0 | Lamar | 44.5 | .152 |
| Bee | 33 | .068 | Lamb | 17.7 | -.122 |
| Bell | 34 | .144 | Lampasas | 30 | .009 |
| Bexar | 31 | .171 | LaSalle | 23 | -.338 |
| Blanco | 32 | .131 | Lavaca | 39 | .147 |
| Borden | 20 | -.102 | Lee | 37 | .08 |
| Bosque | 33 | .133 | Leon | 41 | .059 |
| Bowie | 48 | -.021 | Liberty | 52 | -.149 |
| Brazoria | 49.1 | -.114 | Limestone | 38 | .245 |
| Brazos | 40 | .05 | Lipscomb | 22 | -.04 |
| Brewster | 15.7 | -.263 | Liveoak | 28 | -.108 |
| Briscoe | 20 | -.127 | Llano | 29 | .108 |
| Brooks | 25 | -.208 | Loving | 11 | -.181 |
| Brown | 28 | -.043 | Lubbock | 20 | -.105 |
| Burleson | 39 | .027 | Lynn | 20 | -.106 |
| Burnet | 31 | .077 | Madison | 41 | .042 |
| Caldwell | 35 | .143 | Marion | 47 | -.174 |
| Calhoun | 39.9 | .17 | Martin | 17 | -.097 |
| Callahan | 26.5 | -.112 | Mason | 27 | .225 |
| Cameron | 26.8 | -.232 | Matagorda | 44.2 | .047 |
| Camp | 44 | -.032 | Maverick | 22 | -.211 |
| Carson | 20 | -.061 | McCulloch | 26 | .124 |
| Cass | 47 | -.114 | McLennan | 35 | .188 |
| Castro | 18 | -.143 | McMullen | 25 | -.275 |
| Chambers | 49.8 | -.157 | Medina | 30 | .184 |
| Cherokee | 44 | -.112 | Menard | 25 | .203 |
| Childress | 22 | -.051 | Midland | 16 | -.032 |
| Clay | 31 | .042 | Milam | 36 | .108 |

Table 3.1: Countywide values of mean-annual precipitation and omegaem parameter—Continued

| County name | Mean-annual precipitation (inches) | OmegaEM (dimensionless) | County name | Mean-annual precipitation (inches) | OmegaEM (dimensionless) |
|---------------|------------------------------------|-------------------------|---------------|------------------------------------|-------------------------|
| Cochran | 18 | -.114 | Mills | 28 | -.088 |
| Coke | 23 | -.03 | Mitchell | 21 | -.069 |
| Coleman | 26 | .002 | Montague | 33 | .061 |
| Collin | 39 | .193 | Montgomery | 47 | .023 |
| Collingsworth | 22 | -.03 | Moore | 18 | -.095 |
| Colorado | 39 | .125 | Morris | 46 | -.046 |
| Comal | 34.3 | .161 | Motley | 22 | -.089 |
| Comanche | 30 | -.082 | Nacogdoches | 46 | -.131 |
| Concho | 24 | .089 | Navarro | 37 | .176 |
| Cooke | 37.8 | .114 | Newton | 56 | -.254 |
| Coryell | 31 | .086 | Nolan | 25 | -.067 |
| Cottle | 23 | -.059 | Nueces | 33.2 | -.037 |
| Crane | 13 | .031 | Ochiltree | 20.3 | -.073 |
| Crockett | 18 | .143 | Oldham | 18 | -.09 |
| Crosby | 21 | -.103 | Orange | 58 | -.252 |
| Culberson | 14.6 | -.219 | Palo Pinto | 31.5 | -.005 |
| Dallam | 16 | -.116 | Panola | 48 | -.204 |
| Dallas | 37 | .15 | Parker | 33 | .088 |
| Dawson | 18 | -.119 | Parmer | 17 | -.157 |
| Deaf Smith | 18 | -.118 | Pecos | 15.5 | .003 |
| Delta | 43.7 | .148 | Polk | 48 | -.139 |
| Denton | 38 | .136 | Potter | 19 | -.077 |
| DeWitt | 34 | .166 | Presidio | 15 | -.266 |
| Dickens | 22 | -.088 | Rains | 42 | .081 |
| Dimmit | 22 | -.392 | Randall | 19 | -.113 |
| Donley | 22 | -.06 | Reagan | 18 | .045 |
| Duval | 25 | -.24 | Real | 27.5 | .325 |
| Eastland | 28 | -.086 | Red River | 46.6 | .085 |
| Ector | 14 | -.047 | Reeves | 12.3 | -.221 |
| Edwards | 23.4 | .294 | Refugio | 37 | .143 |
| Ellis | 37 | .151 | Roberts | 20 | -.045 |
| El Paso | 11.4 | -.102 | Robertson | 37 | .142 |
| Erath | 31 | -.002 | Rockwall | 40 | .156 |
| Falls | 35 | .178 | Runnels | 25 | -.016 |
| Fannin | 42.5 | .196 | Rusk | 46 | -.153 |
| Fayette | 38 | .112 | Sabine | 52.2 | -.168 |
| Fisher | 24.3 | -.082 | San Augustine | 49 | -.148 |
| Floyd | 20 | -.122 | San Jacinto | 48 | -.044 |
| Foard | 25 | -.032 | San Patricio | 32 | .06 |

Table 3.1: Countywide values of mean-annual precipitation and omegaem parameter—Continued

| County name | Mean-annual precipitation (inches) | OmegaEM (dimensionless) | County name | Mean-annual precipitation (inches) | OmegaEM (dimensionless) |
|-------------|------------------------------------|-------------------------|--------------|------------------------------------|-------------------------|
| Fort Bend | 44 | -.08 | San Saba | 28 | .031 |
| Franklin | 43.7 | .05 | Schleicher | 23 | .126 |
| Freestone | 41 | .113 | Scurry | 22 | -.089 |
| Frio | 25 | -.126 | Shackelford | 27 | -.115 |
| Gaines | 16 | -.149 | Shelby | 49 | -.169 |
| Galveston | 45.8 | -.133 | Sherman | 18 | -.129 |
| Garza | 21 | -.099 | Smith | 43 | -.072 |
| Gillespie | 30 | .223 | Somervell | 32 | .105 |
| Glasscock | 18 | -.023 | Starr | 22 | -.232 |
| Goliad | 34 | .187 | Stephens | 29 | -.07 |
| Gonzales | 34.5 | .149 | Sterling | 20 | -.021 |
| Gray | 22.3 | -.03 | Stonewall | 24 | -.075 |
| Grayson | 40.2 | .196 | Sutton | 23 | .21 |
| Gregg | 46 | -.161 | Swisher | 20 | -.151 |
| Grimes | 43 | .044 | Tarrant | 34 | .146 |
| Guadalupe | 33 | .163 | Taylor | 26 | -.096 |
| Hale | 19 | -.129 | Terrell | 14.6 | .21 |
| Hall | 21 | -.078 | Terry | 18 | -.11 |
| Hamilton | 31 | .005 | Throckmorton | 28 | -.043 |
| Hansford | 17.7 | -.123 | Titus | 46 | .015 |
| Hardeman | 24 | -.034 | Tom Green | 21 | .022 |
| Hardin | 54 | -.24 | Travis | 32.5 | .128 |
| Harris | 46.8 | -.091 | Trinity | 45 | -.093 |
| Harrison | 47.5 | -.228 | Tyler | 51 | -.223 |
| Hartley | 16 | -.098 | Upshur | 45 | -.087 |
| Haskell | 26.3 | -.062 | Upton | 16 | .043 |
| Hays | 33 | .141 | Uvalde | 26 | .229 |
| Hemphill | 22 | -.018 | Val Verde | 20.2 | .301 |
| Henderson | 40 | .026 | Van Zandt | 41 | .04 |
| Hidalgo | 25 | -.232 | Victoria | 38 | .171 |
| Hill | 35 | .176 | Walker | 45 | .027 |
| Hockley | 19 | -.099 | Waller | 42 | .013 |
| Hood | 32 | .096 | Ward | 11 | -.079 |
| Hopkins | 43.7 | .1 | Washington | 39 | .045 |
| Houston | 41.7 | -.095 | Webb | 23 | -.273 |
| Howard | 19 | -.078 | Wharton | 41.7 | .07 |
| Hudspeth | 13.6 | -.115 | Wheeler | 22 | -.006 |
| Hunt | 41 | .15 | Wichita | 27 | .026 |
| Hutchinson | 19 | -.083 | Wilbarger | 26.5 | -.003 |

Table 3.1: Countywide values of mean-annual precipitation and omegaem parameter—Continued

| County name | Mean-annual precipitation (inches) | OmegaEM (dimensionless) | County name | Mean-annual precipitation (inches) | OmegaEM (dimensionless) |
|-------------|------------------------------------|-------------------------|-------------|------------------------------------|-------------------------|
| Irion | 20 | .047 | Willacy | 26.8 | -.232 |
| Jack | 32 | .027 | Williamson | 33 | .125 |
| Jackson | 40.6 | .157 | Wilson | 30 | .091 |
| Jasper | 53 | -.245 | Winkler | 13 | -.115 |
| Jeff Davis | 17.4 | -.457 | Wise | 35 | .078 |
| Jefferson | 51.7 | -.207 | Wood | 43 | .01 |
| Jim Hogg | 23 | -.232 | Yoakum | 18 | -.133 |
| Jim Wells | 28 | -.146 | Young | 30 | -.018 |
| Johnson | 33 | .169 | Zapata | 21 | -.232 |
| Jones | 24 | -.109 | Zavala | 23 | -.135 |

Table 3.2: Countywide values of scale factor for unified rational method in Texas.

| County name | Scale factor β_T by T -year recurrence interval | | | | | |
|-------------|---|--------|---------|---------|---------|----------|
| | 2 year | 5 year | 10 year | 25 year | 50 year | 100 year |
| Anderson | 0.114 | 0.070 | 0.066 | 0.137 | 0.177 | 0.155 |
| Andrews | 2.243 | 1.800 | 1.329 | 1.334 | 1.361 | 1.385 |
| Angelina | .140 | .101 | .070 | .066 | .056 | .052 |
| Aransas | .113 | .049 | .034 | .029 | .028 | .025 |
| Archer | .267 | .107 | .063 | .043 | .026 | .025 |
| Armstrong | 1.100 | .635 | .553 | .471 | .522 | .564 |
| Atascosa | .845 | .509 | .402 | .405 | .430 | .434 |
| Austin | .089 | .067 | .092 | .083 | .112 | .142 |
| Bailey | 1.269 | .948 | .826 | .799 | .890 | .897 |
| Bandera | .084 | .043 | .042 | .048 | .094 | .085 |
| Bastrop | .080 | .055 | .061 | .080 | .096 | .170 |
| Baylor | .347 | .139 | .084 | .045 | .028 | .022 |
| Bee | .227 | .100 | .075 | .068 | .074 | .075 |
| Bell | .043 | .049 | .043 | .052 | .110 | .139 |
| Bexar | .189 | .121 | .099 | .132 | .189 | .201 |
| Blanco | .156 | .091 | .070 | .058 | .072 | .056 |
| Borden | .816 | .502 | .384 | .354 | .341 | .256 |
| Bosque | .096 | .077 | .085 | .078 | .142 | .173 |
| Bowie | .052 | .040 | .052 | .077 | .100 | .146 |
| Brazoria | .098 | .056 | .059 | .063 | .046 | .064 |
| Brazos | .078 | .058 | .064 | .110 | .178 | .211 |
| Brewster | 4.864 | 3.334 | 2.822 | 2.335 | 2.005 | 1.722 |
| Briscoe | 1.125 | .677 | .562 | .457 | .474 | .465 |
| Brooks | 1.081 | .603 | .496 | .473 | .439 | .454 |
| Brown | .168 | .140 | .145 | .212 | .260 | .260 |
| Burleson | .082 | .069 | .080 | .109 | .191 | .231 |
| Burnet | .188 | .098 | .078 | .084 | .146 | .092 |
| Caldwell | .106 | .064 | .066 | .078 | .111 | .167 |
| Calhoun | .045 | .027 | .019 | .025 | .023 | .025 |
| Callahan | .335 | .234 | .211 | .247 | .255 | .278 |
| Cameron | 1.315 | .877 | .681 | .724 | .634 | .539 |
| Camp | .070 | .053 | .057 | .091 | .133 | .155 |
| Carson | .812 | .568 | .552 | .533 | .682 | .624 |
| Cass | .069 | .051 | .068 | .089 | .116 | .172 |
| Castro | 1.279 | .949 | .828 | .767 | .818 | .838 |
| Chambers | .106 | .052 | .046 | .041 | .035 | .079 |
| Cherokee | .119 | .082 | .072 | .112 | .135 | .151 |
| Childress | .741 | .429 | .348 | .234 | .199 | .139 |
| Clay | .157 | .082 | .057 | .039 | .030 | .031 |
| Cochran | 1.239 | .811 | .702 | .691 | .801 | .840 |
| Coke | .448 | .223 | .159 | .103 | .087 | .075 |

Table 3.2: Countywide values of scale factor for unified rational method in Texas—Continued

| County name | Scale factor β_T by T -year recurrence interval | | | | | |
|---------------|---|--------|---------|---------|---------|----------|
| | 2 year | 5 year | 10 year | 25 year | 50 year | 100 year |
| Coleman | .228 | .167 | .141 | .168 | .177 | .200 |
| Collin | .051 | .031 | .035 | .042 | .075 | .058 |
| Collingsworth | .654 | .451 | .440 | .434 | .498 | .392 |
| Colorado | .074 | .061 | .058 | .078 | .086 | .115 |
| Comal | .117 | .072 | .061 | .072 | .117 | .090 |
| Comanche | .163 | .115 | .137 | .227 | .318 | .324 |
| Concho | .335 | .138 | .107 | .105 | .081 | .087 |
| Cooke | .082 | .048 | .052 | .039 | .081 | .082 |
| Coryell | .082 | .064 | .055 | .103 | .180 | .155 |
| Cottle | .662 | .306 | .225 | .139 | .104 | .085 |
| Crane | 2.423 | 1.469 | 1.058 | .910 | .865 | .858 |
| Crockett | .753 | .321 | .171 | .122 | .093 | .092 |
| Crosby | .772 | .423 | .289 | .323 | .306 | .265 |
| Culberson | 3.572 | 2.504 | 2.226 | 2.031 | 1.918 | 1.804 |
| Dallam | 2.302 | 1.593 | 1.330 | 1.481 | 1.511 | 1.611 |
| Dallas | .072 | .032 | .041 | .056 | .092 | .100 |
| Dawson | 1.148 | .784 | .670 | .657 | .668 | .610 |
| Deaf Smith | 1.401 | .884 | .874 | .808 | .776 | .763 |
| Delta | .053 | .036 | .035 | .049 | .092 | .057 |
| Denton | .080 | .042 | .053 | .038 | .083 | .091 |
| DeWitt | .107 | .060 | .037 | .079 | .105 | .150 |
| Dickens | .739 | .368 | .246 | .230 | .208 | .150 |
| Dimmit | 4.282 | 3.226 | 2.497 | 2.530 | 2.460 | 2.302 |
| Donley | .654 | .441 | .423 | .375 | .463 | .409 |
| Duval | 1.175 | .803 | .614 | .600 | .524 | .457 |
| Eastland | .263 | .172 | .175 | .237 | .324 | .349 |
| Ector | 2.147 | 1.461 | 1.101 | .987 | 1.061 | 1.046 |
| Edwards | .134 | .064 | .056 | .052 | .092 | .104 |
| Ellis | .075 | .032 | .042 | .048 | .088 | .101 |
| El Paso | 2.436 | 2.593 | 2.459 | 1.869 | 1.669 | 1.496 |
| Erath | .182 | .112 | .135 | .151 | .243 | .289 |
| Falls | .054 | .044 | .065 | .071 | .168 | .209 |
| Fannin | .046 | .032 | .035 | .040 | .070 | .054 |
| Fayette | .066 | .051 | .061 | .091 | .118 | .174 |
| Fisher | .480 | .248 | .173 | .144 | .124 | .066 |
| Floyd | 1.086 | .622 | .450 | .403 | .434 | .368 |
| Foard | .512 | .212 | .145 | .075 | .047 | .036 |
| Fort Bend | .151 | .094 | .098 | .104 | .088 | .100 |
| Franklin | .061 | .049 | .048 | .074 | .121 | .110 |
| Freestone | .065 | .031 | .038 | .084 | .128 | .104 |
| Frio | 1.164 | .657 | .537 | .519 | .542 | .513 |

Table 3.2: Countywide values of scale factor for unified rational method in Texas—Continued

| County name | Scale factor β_T by T -year recurrence interval | | | | | |
|-------------|---|--------|---------|---------|---------|----------|
| | 2 year | 5 year | 10 year | 25 year | 50 year | 100 year |
| Gaines | 1.932 | 1.391 | 1.158 | 1.101 | 1.349 | 1.313 |
| Galveston | .143 | .057 | .057 | .040 | .031 | .082 |
| Garza | .637 | .407 | .291 | .308 | .306 | .223 |
| Gillespie | .113 | .061 | .053 | .047 | .061 | .057 |
| Glasscock | .930 | .472 | .328 | .304 | .253 | .180 |
| Goliad | .102 | .043 | .032 | .042 | .042 | .066 |
| Gonzales | .108 | .073 | .051 | .102 | .139 | .192 |
| Gray | .610 | .423 | .452 | .466 | .635 | .542 |
| Grayson | .046 | .034 | .041 | .036 | .063 | .056 |
| Gregg | .106 | .083 | .078 | .114 | .120 | .155 |
| Grimes | .078 | .060 | .059 | .090 | .136 | .179 |
| Guadalupe | .139 | .095 | .078 | .118 | .151 | .173 |
| Hale | 1.214 | .706 | .557 | .523 | .583 | .572 |
| Hall | .828 | .489 | .407 | .328 | .306 | .249 |
| Hamilton | .145 | .085 | .110 | .156 | .242 | .222 |
| Hansford | 1.544 | 1.308 | 1.176 | 1.293 | 1.404 | 1.490 |
| Hardeman | .542 | .261 | .192 | .088 | .062 | .050 |
| Hardin | .129 | .072 | .061 | .091 | .090 | .096 |
| Harris | .135 | .068 | .074 | .075 | .068 | .090 |
| Harrison | .115 | .085 | .085 | .096 | .098 | .110 |
| Hartley | 2.033 | 1.385 | 1.147 | 1.266 | 1.251 | 1.252 |
| Haskell | .449 | .220 | .160 | .093 | .074 | .039 |
| Hays | .124 | .072 | .062 | .067 | .089 | .083 |
| Hemphill | .681 | .503 | .506 | .637 | .767 | .713 |
| Henderson | .075 | .041 | .050 | .106 | .157 | .142 |
| Hidalgo | 1.441 | .953 | .783 | .733 | .633 | .565 |
| Hill | .076 | .041 | .057 | .051 | .097 | .123 |
| Hockley | .922 | .631 | .479 | .514 | .555 | .538 |
| Hood | .157 | .101 | .118 | .089 | .154 | .191 |
| Hopkins | .052 | .036 | .040 | .054 | .111 | .078 |
| Houston | .167 | .117 | .088 | .117 | .152 | .147 |
| Howard | .802 | .542 | .379 | .352 | .304 | .228 |
| Hudspeth | 2.443 | 1.773 | 1.381 | 1.453 | 1.224 | 1.300 |
| Hunt | .046 | .031 | .036 | .047 | .095 | .058 |
| Hutchinson | 1.126 | .882 | .778 | .839 | 1.010 | .991 |
| Irion | .645 | .293 | .174 | .102 | .084 | .050 |
| Jack | .173 | .110 | .102 | .089 | .108 | .135 |
| Jackson | .045 | .031 | .023 | .033 | .036 | .040 |
| Jasper | .150 | .100 | .070 | .098 | .078 | .076 |
| Jeff Davis | 4.900 | 4.544 | 3.645 | 3.702 | 3.221 | 2.962 |
| Jefferson | .115 | .055 | .048 | .056 | .050 | .084 |

Table 3.2: Countywide values of scale factor for unified rational method in Texas—Continued

| County name | Scale factor β_T by T -year recurrence interval | | | | | |
|-------------|---|--------|---------|---------|---------|----------|
| | 2 year | 5 year | 10 year | 25 year | 50 year | 100 year |
| Jim Hogg | 1.523 | .917 | .704 | .697 | .632 | .647 |
| Jim Wells | .632 | .322 | .254 | .248 | .229 | .182 |
| Johnson | .127 | .068 | .082 | .057 | .109 | .128 |
| Jones | .578 | .346 | .249 | .182 | .184 | .133 |
| Karnes | .270 | .136 | .095 | .127 | .173 | .227 |
| Kaufman | .058 | .031 | .036 | .065 | .092 | .108 |
| Kendall | .107 | .063 | .059 | .060 | .091 | .062 |
| Kenedy | .889 | .503 | .416 | .379 | .339 | .285 |
| Kent | .646 | .357 | .254 | .251 | .232 | .127 |
| Kerr | .066 | .033 | .034 | .038 | .068 | .072 |
| Kimble | .084 | .035 | .035 | .034 | .043 | .041 |
| King | .600 | .258 | .199 | .125 | .120 | .067 |
| Kinney | .268 | .133 | .108 | .107 | .159 | .158 |
| Kleberg | .518 | .244 | .194 | .167 | .165 | .138 |
| Knox | .430 | .177 | .124 | .063 | .046 | .029 |
| Lamar | .056 | .036 | .037 | .047 | .086 | .064 |
| Lamb | 1.252 | .899 | .737 | .719 | .713 | .773 |
| Lampasas | .185 | .109 | .104 | .139 | .230 | .148 |
| LaSalle | 2.802 | 2.089 | 1.767 | 1.535 | 1.490 | 1.366 |
| Lavaca | .067 | .044 | .032 | .068 | .095 | .113 |
| Lee | .073 | .057 | .064 | .098 | .138 | .177 |
| Leon | .093 | .048 | .047 | .092 | .121 | .110 |
| Liberty | .098 | .056 | .052 | .066 | .062 | .088 |
| Limestone | .054 | .026 | .039 | .068 | .122 | .113 |
| Lipscomb | .685 | .535 | .535 | .729 | .813 | .824 |
| Liveoak | .771 | .429 | .329 | .310 | .294 | .232 |
| Llano | .247 | .113 | .092 | .088 | .109 | .084 |
| Loving | 6.101 | 4.789 | 3.546 | 3.367 | 3.569 | 3.169 |
| Lubbock | .885 | .505 | .378 | .402 | .411 | .395 |
| Lynn | .830 | .532 | .384 | .440 | .408 | .389 |
| Madison | .092 | .065 | .055 | .100 | .125 | .122 |
| Marion | .091 | .069 | .077 | .100 | .111 | .153 |
| Martin | 1.194 | .910 | .720 | .692 | .675 | .641 |
| Mason | .176 | .061 | .055 | .050 | .059 | .051 |
| Matagorda | .054 | .034 | .033 | .034 | .039 | .034 |
| Maverick | 2.247 | 1.316 | 1.100 | 1.052 | 1.063 | 1.055 |
| McCulloch | .229 | .101 | .099 | .098 | .100 | .084 |
| McLennan | .033 | .042 | .046 | .051 | .115 | .168 |
| McMullen | 2.068 | 1.253 | 1.023 | .967 | .916 | .767 |
| Medina | .189 | .107 | .102 | .100 | .154 | .156 |
| Menard | .166 | .065 | .062 | .045 | .044 | .039 |

Table 3.2: Countywide values of scale factor for unified rational method in Texas—Continued

| County name | Scale factor β_T by T -year recurrence interval | | | | | |
|---------------|---|--------|---------|---------|---------|----------|
| | 2 year | 5 year | 10 year | 25 year | 50 year | 100 year |
| Midland | 1.350 | .833 | .657 | .563 | .552 | .511 |
| Milam | .068 | .052 | .066 | .076 | .136 | .166 |
| Mills | .258 | .186 | .203 | .270 | .347 | .272 |
| Mitchell | .549 | .337 | .248 | .209 | .148 | .096 |
| Montague | .128 | .074 | .066 | .056 | .088 | .089 |
| Montgomery | .072 | .050 | .049 | .068 | .079 | .099 |
| Moore | 1.402 | 1.019 | .848 | .893 | 1.090 | 1.051 |
| Morris | .058 | .048 | .055 | .085 | .117 | .153 |
| Motley | .806 | .395 | .295 | .240 | .209 | .170 |
| Nacogdoches | .120 | .071 | .060 | .046 | .045 | .038 |
| Navarro | .057 | .025 | .034 | .061 | .099 | .098 |
| Newton | .142 | .094 | .065 | .093 | .068 | .074 |
| Nolan | .355 | .192 | .130 | .111 | .089 | .055 |
| Nueces | .275 | .124 | .095 | .071 | .068 | .052 |
| Ochiltree | .878 | .744 | .713 | .842 | 1.001 | 1.001 |
| Oldham | 1.354 | .921 | .747 | .757 | .762 | .738 |
| Orange | .094 | .056 | .044 | .069 | .067 | .077 |
| Palo Pinto | .199 | .137 | .134 | .135 | .180 | .242 |
| Panola | .117 | .067 | .063 | .051 | .044 | .041 |
| Parker | .136 | .091 | .105 | .078 | .124 | .163 |
| Parmer | 1.971 | 1.195 | 1.046 | 1.091 | 1.054 | 1.105 |
| Pecos | 1.984 | 1.211 | .759 | .648 | .585 | .597 |
| Polk | .127 | .083 | .066 | .091 | .094 | .102 |
| Potter | 1.104 | .700 | .605 | .597 | .642 | .629 |
| Presidio | 4.660 | 3.582 | 2.851 | 2.613 | 2.159 | 1.871 |
| Rains | .054 | .033 | .041 | .066 | .127 | .102 |
| Randall | 1.098 | .731 | .615 | .574 | .610 | .647 |
| Reagan | .819 | .411 | .274 | .205 | .145 | .107 |
| Real | .067 | .039 | .037 | .042 | .083 | .097 |
| Red River | .059 | .043 | .041 | .063 | .090 | .095 |
| Reeves | 5.333 | 4.505 | 3.282 | 3.204 | 3.119 | 2.838 |
| Refugio | .083 | .035 | .026 | .027 | .027 | .029 |
| Roberts | .856 | .687 | .661 | .744 | .881 | .874 |
| Robertson | .075 | .046 | .056 | .098 | .162 | .164 |
| Rockwall | .048 | .027 | .031 | .048 | .085 | .071 |
| Runnels | .351 | .185 | .147 | .139 | .124 | .160 |
| Rusk | .103 | .075 | .065 | .079 | .075 | .088 |
| Sabine | .141 | .092 | .064 | .049 | .032 | .034 |
| San Augustine | .138 | .086 | .053 | .048 | .032 | .031 |
| San Jacinto | .086 | .057 | .050 | .075 | .081 | .098 |
| San Patricio | .231 | .095 | .068 | .054 | .052 | .037 |

Table 3.2: Countywide values of scale factor for unified rational method in Texas—Continued

| County name | Scale factor β_T by T -year recurrence interval | | | | | |
|--------------|---|--------|---------|---------|---------|----------|
| | 2 year | 5 year | 10 year | 25 year | 50 year | 100 year |
| San Saba | .278 | .122 | .123 | .145 | .188 | .127 |
| Schleicher | .345 | .129 | .088 | .059 | .051 | .032 |
| Scurry | .510 | .325 | .252 | .230 | .192 | .114 |
| Shackelford | .416 | .242 | .210 | .185 | .182 | .160 |
| Shelby | .122 | .069 | .048 | .035 | .028 | .030 |
| Sherman | 1.598 | 1.255 | 1.170 | 1.252 | 1.320 | 1.419 |
| Smith | .085 | .065 | .073 | .130 | .157 | .191 |
| Somervell | .158 | .104 | .121 | .092 | .165 | .199 |
| Starr | 1.890 | 1.262 | 1.120 | .982 | .804 | .830 |
| Stephens | .303 | .171 | .153 | .185 | .222 | .214 |
| Sterling | .608 | .322 | .202 | .159 | .101 | .076 |
| Stonewall | .540 | .268 | .206 | .147 | .147 | .071 |
| Sutton | .199 | .094 | .065 | .054 | .049 | .031 |
| Swisher | 1.109 | .675 | .572 | .530 | .605 | .635 |
| Tarrant | .121 | .058 | .070 | .049 | .105 | .122 |
| Taylor | .356 | .221 | .180 | .158 | .177 | .175 |
| Terrell | 1.228 | .508 | .260 | .226 | .167 | .168 |
| Terry | 1.186 | .787 | .625 | .663 | .728 | .724 |
| Throckmorton | .327 | .165 | .105 | .082 | .059 | .035 |
| Titus | .053 | .046 | .047 | .071 | .107 | .129 |
| Tom Green | .660 | .282 | .182 | .139 | .115 | .092 |
| Travis | .115 | .075 | .078 | .064 | .098 | .090 |
| Trinity | .131 | .092 | .065 | .080 | .092 | .102 |
| Tyler | .161 | .110 | .076 | .099 | .094 | .087 |
| Upshur | .071 | .063 | .068 | .108 | .135 | .177 |
| Upton | 1.302 | .735 | .501 | .395 | .404 | .368 |
| Uvalde | .223 | .110 | .098 | .107 | .149 | .134 |
| Val Verde | .263 | .111 | .065 | .062 | .069 | .066 |
| Van Zandt | .064 | .036 | .048 | .091 | .130 | .139 |
| Victoria | .055 | .034 | .024 | .036 | .037 | .047 |
| Walker | .084 | .060 | .045 | .076 | .097 | .113 |
| Waller | .115 | .073 | .088 | .089 | .110 | .121 |
| Ward | 4.732 | 3.152 | 2.670 | 2.383 | 2.360 | 2.224 |
| Washington | .079 | .072 | .087 | .096 | .166 | .232 |
| Webb | 2.372 | 1.320 | 1.130 | 1.018 | .947 | .785 |
| Wharton | .076 | .052 | .044 | .058 | .066 | .071 |
| Wheeler | .650 | .471 | .439 | .531 | .673 | .567 |
| Wichita | .290 | .113 | .070 | .035 | .025 | .021 |
| Wilbarger | .368 | .144 | .095 | .048 | .027 | .026 |
| Willacy | 1.298 | .869 | .634 | .631 | .592 | .447 |
| Williamson | .078 | .064 | .066 | .047 | .102 | .091 |

Table 3.2: Countywide values of scale factor for unified rational method in Texas—Continued

| County name | Scale factor β_T by T -year recurrence interval | | | | | |
|-------------|---|--------|---------|---------|---------|----------|
| | 2 year | 5 year | 10 year | 25 year | 50 year | 100 year |
| Wilson | .292 | .173 | .127 | .181 | .237 | .302 |
| Winkler | 3.588 | 2.356 | 1.943 | 1.859 | 1.966 | 1.887 |
| Wise | .119 | .082 | .081 | .048 | .099 | .124 |
| Wood | .059 | .046 | .055 | .095 | .147 | .159 |
| Yoakum | 1.264 | .972 | .803 | .794 | .936 | .990 |
| Young | .233 | .119 | .092 | .096 | .081 | .076 |
| Zapata | 2.196 | 1.362 | 1.015 | .977 | .876 | .828 |
| Zavala | 1.542 | .916 | .735 | .660 | .691 | .683 |

Table 3.3: Countywide values of exponent on drainage area for unified rational method in Texas.

| County name | Exponent α_T by T -year recurrence interval | | | | | |
|-------------|--|--------|---------|---------|---------|----------|
| | 2 year | 5 year | 10 year | 25 year | 50 year | 100 year |
| Anderson | 0.555 | 0.408 | 0.336 | 0.214 | 0.151 | 0.092 |
| Andrews | .421 | .287 | .263 | .187 | .142 | .076 |
| Angelina | .541 | .387 | .335 | .244 | .177 | .114 |
| Aransas | .561 | .423 | .360 | .257 | .181 | .104 |
| Archer | .506 | .401 | .350 | .251 | .188 | .112 |
| Armstrong | .432 | .333 | .272 | .205 | .144 | .086 |
| Atascosa | .458 | .339 | .294 | .203 | .147 | .090 |
| Austin | .562 | .392 | .304 | .220 | .153 | .094 |
| Bailey | .439 | .321 | .266 | .193 | .131 | .085 |
| Bandera | .557 | .404 | .326 | .226 | .150 | .095 |
| Bastrop | .571 | .405 | .322 | .220 | .155 | .091 |
| Baylor | .491 | .388 | .336 | .260 | .193 | .121 |
| Bee | .512 | .393 | .328 | .238 | .170 | .104 |
| Bell | .621 | .409 | .334 | .229 | .151 | .094 |
| Bexar | .514 | .368 | .306 | .208 | .143 | .085 |
| Blanco | .527 | .382 | .318 | .233 | .160 | .105 |
| Borden | .458 | .346 | .287 | .208 | .152 | .097 |
| Bosque | .553 | .382 | .305 | .217 | .146 | .085 |
| Bowie | .583 | .409 | .317 | .218 | .150 | .092 |
| Brazoria | .568 | .418 | .339 | .239 | .180 | .113 |
| Brazos | .568 | .402 | .323 | .212 | .145 | .084 |
| Brewster | .355 | .265 | .218 | .163 | .125 | .079 |
| Briscoe | .439 | .334 | .276 | .210 | .150 | .100 |
| Brooks | .467 | .357 | .308 | .218 | .159 | .096 |
| Brown | .554 | .392 | .315 | .209 | .147 | .092 |
| Burleson | .576 | .396 | .316 | .217 | .142 | .089 |
| Burnet | .514 | .384 | .320 | .224 | .146 | .100 |
| Caldwell | .549 | .397 | .320 | .225 | .149 | .089 |
| Calhoun | .608 | .430 | .359 | .236 | .163 | .100 |
| Callahan | .528 | .379 | .309 | .216 | .153 | .096 |
| Cameron | .456 | .343 | .292 | .199 | .148 | .097 |
| Camp | .576 | .403 | .326 | .218 | .147 | .094 |
| Carson | .465 | .339 | .271 | .198 | .125 | .082 |
| Cass | .585 | .417 | .327 | .223 | .158 | .089 |
| Castro | .446 | .326 | .268 | .199 | .136 | .088 |
| Chambers | .574 | .431 | .360 | .262 | .186 | .106 |
| Cherokee | .554 | .399 | .332 | .225 | .156 | .099 |
| Childress | .463 | .343 | .289 | .225 | .163 | .114 |
| Clay | .536 | .393 | .340 | .253 | .182 | .109 |
| Cochran | .434 | .329 | .267 | .192 | .133 | .081 |
| Coke | .489 | .376 | .314 | .237 | .172 | .108 |

Table 3.3: Countywide values of exponent on drainage area for unified rational method in Texas—
Continued

| County name | Exponent α_T by T -year recurrence interval | | | | | |
|---------------|--|--------|---------|---------|---------|----------|
| | 2 year | 5 year | 10 year | 25 year | 50 year | 100 year |
| Coleman | .530 | .379 | .316 | .218 | .156 | .095 |
| Collin | .575 | .408 | .319 | .217 | .148 | .094 |
| Collingsworth | .464 | .340 | .269 | .193 | .133 | .092 |
| Colorado | .571 | .394 | .320 | .219 | .155 | .091 |
| Comal | .538 | .385 | .318 | .224 | .150 | .097 |
| Comanche | .557 | .404 | .320 | .209 | .144 | .083 |
| Concho | .488 | .383 | .322 | .221 | .165 | .104 |
| Cooke | .553 | .398 | .317 | .232 | .153 | .095 |
| Coryell | .586 | .408 | .335 | .220 | .148 | .090 |
| Cottle | .462 | .364 | .304 | .235 | .179 | .118 |
| Crane | .398 | .303 | .254 | .185 | .135 | .082 |
| Crockett | .453 | .352 | .317 | .235 | .167 | .103 |
| Crosby | .474 | .353 | .312 | .206 | .149 | .094 |
| Culberson | .376 | .282 | .227 | .167 | .118 | .073 |
| Dallam | .392 | .300 | .250 | .173 | .126 | .078 |
| Dallas | .565 | .421 | .328 | .222 | .148 | .090 |
| Dawson | .452 | .336 | .270 | .195 | .140 | .087 |
| Deaf Smith | .424 | .325 | .254 | .189 | .136 | .085 |
| Delta | .564 | .394 | .319 | .215 | .142 | .095 |
| Denton | .550 | .404 | .317 | .229 | .150 | .090 |
| DeWitt | .554 | .404 | .344 | .222 | .153 | .090 |
| Dickens | .463 | .361 | .314 | .218 | .160 | .098 |
| Dimmit | .402 | .286 | .264 | .174 | .125 | .078 |
| Donley | .470 | .342 | .277 | .205 | .141 | .094 |
| Duval | .470 | .344 | .295 | .213 | .158 | .104 |
| Eastland | .530 | .394 | .317 | .217 | .142 | .087 |
| Ector | .421 | .306 | .263 | .190 | .137 | .083 |
| Edwards | .549 | .407 | .332 | .239 | .156 | .096 |
| Ellis | .561 | .422 | .328 | .227 | .149 | .090 |
| El Paso | .393 | .269 | .212 | .158 | .120 | .071 |
| Erath | .534 | .392 | .305 | .214 | .146 | .087 |
| Falls | .589 | .402 | .308 | .217 | .138 | .082 |
| Fannin | .572 | .393 | .313 | .215 | .145 | .087 |
| Fayette | .586 | .406 | .318 | .217 | .150 | .088 |
| Fisher | .485 | .371 | .311 | .225 | .167 | .118 |
| Floyd | .442 | .337 | .291 | .210 | .149 | .100 |
| Foard | .472 | .372 | .318 | .247 | .188 | .121 |
| Fort Bend | .542 | .393 | .321 | .224 | .167 | .100 |
| Franklin | .572 | .396 | .323 | .215 | .142 | .092 |
| Freestone | .568 | .420 | .331 | .210 | .143 | .095 |

Table 3.3: Countywide values of exponent on drainage area for unified rational method in Texas—
Continued

| County name | Exponent α_T by T -year recurrence interval | | | | | |
|-------------|--|--------|---------|---------|---------|----------|
| | 2 year | 5 year | 10 year | 25 year | 50 year | 100 year |
| Frio | .446 | .348 | .291 | .209 | .149 | .096 |
| Gaines | .430 | .314 | .267 | .196 | .136 | .088 |
| Galveston | .555 | .430 | .350 | .263 | .194 | .112 |
| Garza | .490 | .352 | .308 | .208 | .146 | .095 |
| Gillespie | .544 | .396 | .322 | .236 | .159 | .103 |
| Glasscock | .448 | .350 | .302 | .205 | .151 | .098 |
| Goliad | .554 | .418 | .351 | .235 | .171 | .099 |
| Gonzales | .552 | .393 | .333 | .213 | .145 | .088 |
| Gray | .461 | .338 | .263 | .188 | .127 | .084 |
| Grayson | .579 | .399 | .311 | .220 | .148 | .094 |
| Gregg | .563 | .398 | .328 | .222 | .163 | .099 |
| Grimes | .560 | .393 | .317 | .217 | .146 | .089 |
| Guadalupe | .534 | .380 | .315 | .206 | .145 | .090 |
| Hale | .442 | .335 | .281 | .204 | .139 | .087 |
| Hall | .464 | .351 | .287 | .215 | .146 | .098 |
| Hamilton | .548 | .404 | .312 | .213 | .146 | .088 |
| Hansford | .428 | .303 | .247 | .172 | .123 | .075 |
| Hardeman | .480 | .361 | .314 | .248 | .188 | .120 |
| Hardin | .561 | .415 | .351 | .235 | .175 | .108 |
| Harris | .542 | .405 | .326 | .229 | .169 | .102 |
| Harrison | .563 | .407 | .334 | .234 | .166 | .100 |
| Hartley | .401 | .302 | .252 | .178 | .127 | .085 |
| Haskell | .482 | .370 | .315 | .241 | .179 | .121 |
| Hays | .538 | .391 | .324 | .229 | .160 | .096 |
| Hemphill | .453 | .327 | .258 | .175 | .120 | .080 |
| Henderson | .580 | .421 | .334 | .214 | .143 | .093 |
| Hidalgo | .453 | .335 | .281 | .207 | .151 | .101 |
| Hill | .562 | .407 | .315 | .224 | .148 | .088 |
| Hockley | .451 | .334 | .281 | .199 | .141 | .093 |
| Hood | .529 | .376 | .301 | .218 | .145 | .091 |
| Hopkins | .576 | .404 | .322 | .221 | .140 | .094 |
| Houston | .536 | .383 | .328 | .222 | .156 | .101 |
| Howard | .463 | .339 | .290 | .206 | .155 | .099 |
| Hudspeth | .382 | .274 | .244 | .154 | .113 | .060 |
| Hunt | .587 | .410 | .323 | .220 | .145 | .095 |
| Hutchinson | .432 | .310 | .257 | .180 | .124 | .079 |
| Irion | .464 | .360 | .311 | .236 | .170 | .114 |
| Jack | .528 | .387 | .314 | .226 | .159 | .097 |
| Jackson | .606 | .424 | .350 | .234 | .164 | .097 |
| Jasper | .545 | .397 | .343 | .235 | .176 | .106 |

Table 3.3: Countywide values of exponent on drainage area for unified rational method in Texas—
Continued

| County name | Exponent α_T by T -year recurrence interval | | | | | |
|----------------|--|-----------|------------|------------|------------|-------------|
| | 2 year | 5 year | 10 year | 25 year | 50 year | 100 year |
| Jeff Davis | .368 | .258 | .233 | .172 | .136 | .090 |
| Jefferson | .574 | .433 | .362 | .252 | .184 | .108 |
| Jim Hogg | .439 | .342 | .298 | .212 | .154 | .096 |
| Jim Wells | .491 | .375 | .316 | .223 | .165 | .107 |
| Johnson | .528 | .388 | .302 | .223 | .146 | .091 |
| Jones | .486 | .360 | .309 | .233 | .168 | .114 |
| Karnes | .502 | .378 | .323 | .221 | .146 | .089 |
| Kaufman | .582 | .423 | .334 | .217 | .150 | .091 |
| Kendall | .548 | .392 | .319 | .229 | .153 | .103 |
| Kenedy | .469 | .366 | .302 | .224 | .168 | .112 |
| Kent | .478 | .364 | .306 | .213 | .158 | .102 |
| Kerr | .580 | .418 | .333 | .233 | .156 | .098 |
| Kimble | .563 | .423 | .336 | .237 | .163 | .099 |
| King | .465 | .364 | .301 | .235 | .168 | .116 |
| Kinney | .506 | .382 | .316 | .226 | .156 | .093 |
| Kleberg | .497 | .391 | .328 | .235 | .170 | .110 |
| Knox | .477 | .381 | .320 | .250 | .192 | .119 |
| Lamar | .557 | .389 | .313 | .213 | .140 | .093 |
| Lamb | .446 | .326 | .271 | .195 | .142 | .086 |
| Lampasas | .531 | .395 | .318 | .217 | .140 | .097 |
| LaSalle | .423 | .317 | .267 | .204 | .152 | .085 |
| Lavaca | .579 | .409 | .341 | .221 | .150 | .095 |
| Lee | .584 | .403 | .325 | .217 | .150 | .089 |
| Leon | .549 | .409 | .331 | .214 | .149 | .097 |
| Liberty | .566 | .416 | .345 | .235 | .175 | .102 |
| Limestone | .563 | .413 | .313 | .205 | .136 | .086 |
| Lipscomb | .456 | .330 | .260 | .172 | .122 | .080 |
| Liveoak | .461 | .354 | .302 | .211 | .156 | .099 |
| Llano | .495 | .378 | .314 | .223 | .151 | .102 |
| Loving | .374 | .264 | .234 | .175 | .119 | .082 |
| Lubbock | .449 | .347 | .292 | .203 | .148 | .092 |
| Lynn | .454 | .343 | .291 | .199 | .146 | .092 |
| Madison | .555 | .395 | .329 | .214 | .152 | .095 |
| Marion | .576 | .408 | .328 | .226 | .161 | .098 |
| Martin | .456 | .326 | .269 | .191 | .142 | .088 |
| Mason | .511 | .400 | .325 | .233 | .160 | .104 |
| Matagorda | .606 | .433 | .349 | .243 | .172 | .106 |
| Maverick | .415 | .323 | .276 | .192 | .135 | .088 |
| McCulloch | .504 | .386 | .310 | .221 | .162 | .102 |
| McLennan | .626 | .401 | .320 | .223 | .145 | .088 |

Table 3.3: Countywide values of exponent on drainage area for unified rational method in Texas—
Continued

| County name | Exponent α_T by T -year recurrence interval | | | | | |
|-------------|--|--------|---------|---------|---------|----------|
| | 2 year | 5 year | 10 year | 25 year | 50 year | 100 year |
| McMullen | .415 | .324 | .276 | .196 | .142 | .095 |
| Medina | .518 | .378 | .306 | .220 | .149 | .090 |
| Menard | .527 | .409 | .328 | .243 | .177 | .107 |
| Midland | .442 | .329 | .269 | .201 | .145 | .091 |
| Milam | .583 | .409 | .317 | .222 | .148 | .090 |
| Mills | .528 | .387 | .307 | .210 | .140 | .091 |
| Mitchell | .494 | .366 | .305 | .219 | .169 | .105 |
| Montague | .539 | .394 | .324 | .236 | .162 | .099 |
| Montgomery | .566 | .399 | .327 | .225 | .163 | .097 |
| Moore | .425 | .309 | .261 | .187 | .121 | .082 |
| Morris | .591 | .410 | .327 | .219 | .149 | .093 |
| Motley | .457 | .358 | .305 | .220 | .163 | .097 |
| Nacogdoches | .551 | .406 | .341 | .253 | .181 | .117 |
| Navarro | .581 | .430 | .333 | .218 | .144 | .093 |
| Newton | .542 | .394 | .343 | .232 | .179 | .111 |
| Nolan | .516 | .380 | .326 | .231 | .170 | .116 |
| Nueces | .515 | .399 | .332 | .247 | .182 | .116 |
| Ochiltree | .458 | .313 | .257 | .178 | .116 | .075 |
| Oldham | .420 | .310 | .265 | .190 | .137 | .086 |
| Orange | .577 | .428 | .359 | .247 | .179 | .115 |
| Palo Pinto | .522 | .378 | .306 | .218 | .153 | .088 |
| Panola | .558 | .415 | .343 | .250 | .185 | .113 |
| Parker | .536 | .385 | .304 | .220 | .149 | .091 |
| Parmer | .409 | .321 | .264 | .191 | .140 | .089 |
| Pecos | .390 | .294 | .262 | .189 | .138 | .087 |
| Polk | .553 | .401 | .340 | .233 | .162 | .099 |
| Potter | .429 | .321 | .267 | .191 | .137 | .084 |
| Presidio | .362 | .259 | .214 | .155 | .119 | .077 |
| Rains | .584 | .420 | .329 | .219 | .143 | .091 |
| Randall | .443 | .329 | .275 | .205 | .145 | .089 |
| Reagan | .464 | .351 | .303 | .223 | .167 | .112 |
| Real | .584 | .414 | .334 | .231 | .153 | .096 |
| Red River | .556 | .387 | .314 | .211 | .146 | .092 |
| Reeves | .368 | .254 | .232 | .167 | .119 | .077 |
| Refugio | .569 | .428 | .357 | .242 | .172 | .101 |
| Roberts | .457 | .326 | .258 | .178 | .124 | .072 |
| Robertson | .562 | .402 | .320 | .208 | .143 | .088 |
| Rockwall | .587 | .422 | .331 | .220 | .148 | .093 |
| Runnels | .501 | .382 | .318 | .228 | .159 | .096 |
| Rusk | .567 | .403 | .339 | .233 | .172 | .105 |

Table 3.3: Countywide values of exponent on drainage area for unified rational method in Texas—
Continued

| County name | Exponent α_T by T -year recurrence interval | | | | | |
|---------------|--|--------|---------|---------|---------|----------|
| | 2 year | 5 year | 10 year | 25 year | 50 year | 100 year |
| Sabine | .525 | .385 | .334 | .247 | .193 | .114 |
| San Augustine | .535 | .392 | .349 | .251 | .184 | .112 |
| San Jacinto | .563 | .405 | .336 | .226 | .167 | .098 |
| San Patricio | .519 | .402 | .341 | .247 | .173 | .114 |
| San Saba | .501 | .386 | .311 | .218 | .147 | .094 |
| Schleicher | .489 | .384 | .332 | .240 | .173 | .109 |
| Scurry | .496 | .367 | .309 | .215 | .160 | .100 |
| Shackelford | .507 | .375 | .308 | .223 | .161 | .103 |
| Shelby | .541 | .403 | .348 | .262 | .189 | .120 |
| Sherman | .419 | .301 | .244 | .171 | .124 | .074 |
| Smith | .573 | .407 | .329 | .214 | .154 | .089 |
| Somervell | .526 | .372 | .297 | .214 | .142 | .090 |
| Starr | .434 | .330 | .270 | .200 | .154 | .094 |
| Stephens | .511 | .383 | .316 | .218 | .154 | .091 |
| Sterling | .480 | .364 | .317 | .234 | .180 | .120 |
| Stonewall | .474 | .368 | .304 | .225 | .164 | .116 |
| Sutton | .531 | .395 | .338 | .238 | .174 | .110 |
| Swisher | .447 | .337 | .284 | .204 | .140 | .086 |
| Tarrant | .532 | .399 | .312 | .226 | .148 | .092 |
| Taylor | .519 | .377 | .312 | .227 | .159 | .100 |
| Terrell | .425 | .333 | .294 | .209 | .153 | .099 |
| Terry | .445 | .331 | .272 | .191 | .135 | .086 |
| Throckmorton | .499 | .382 | .332 | .241 | .182 | .120 |
| Titus | .584 | .399 | .325 | .219 | .148 | .091 |
| Tom Green | .459 | .361 | .309 | .227 | .164 | .106 |
| Travis | .553 | .393 | .313 | .231 | .155 | .100 |
| Trinity | .548 | .391 | .339 | .234 | .169 | .098 |
| Tyler | .541 | .390 | .339 | .235 | .170 | .102 |
| Upshur | .584 | .406 | .327 | .216 | .154 | .091 |
| Upton | .427 | .322 | .282 | .200 | .139 | .090 |
| Uvalde | .515 | .381 | .314 | .218 | .150 | .098 |
| Val Verde | .506 | .383 | .333 | .235 | .171 | .101 |
| Van Zandt | .584 | .425 | .333 | .213 | .147 | .089 |
| Victoria | .597 | .423 | .353 | .238 | .164 | .102 |
| Walker | .555 | .393 | .336 | .224 | .156 | .097 |
| Waller | .542 | .395 | .310 | .221 | .157 | .092 |
| Ward | .362 | .283 | .228 | .164 | .117 | .070 |
| Washington | .579 | .392 | .313 | .218 | .142 | .084 |
| Webb | .414 | .333 | .276 | .206 | .148 | .106 |
| Wharton | .574 | .409 | .340 | .231 | .161 | .099 |

Table 3.3: Countywide values of exponent on drainage area for unified rational method in Texas—
Continued

| County name | Exponent α_T by T -year recurrence interval | | | | | |
|-------------|--|--------|---------|---------|---------|----------|
| | 2 year | 5 year | 10 year | 25 year | 50 year | 100 year |
| Wheeler | .456 | .328 | .264 | .180 | .122 | .083 |
| Wichita | .504 | .391 | .343 | .259 | .183 | .114 |
| Wilbarger | .486 | .384 | .329 | .259 | .195 | .125 |
| Willacy | .452 | .341 | .294 | .204 | .150 | .099 |
| Williamson | .581 | .401 | .320 | .240 | .152 | .099 |
| Wilson | .499 | .368 | .311 | .209 | .140 | .086 |
| Winkler | .382 | .286 | .234 | .163 | .112 | .070 |
| Wise | .538 | .384 | .310 | .237 | .154 | .094 |
| Wood | .591 | .410 | .327 | .212 | .146 | .088 |
| Yoakum | .439 | .318 | .265 | .189 | .135 | .082 |
| Young | .520 | .394 | .332 | .227 | .170 | .108 |
| Zapata | .426 | .330 | .286 | .208 | .154 | .099 |
| Zavala | .437 | .337 | .282 | .206 | .137 | .082 |

Table 3.4: Countywide values of exponent on dimensionless main-channel slope for unified rational method in Texas.

| County name | Exponent κ_T by T -year recurrence interval | | | | | |
|-------------|--|--------|---------|---------|---------|----------|
| | 2 year | 5 year | 10 year | 25 year | 50 year | 100 year |
| Anderson | 0.459 | 0.661 | 0.729 | 0.739 | 0.762 | 0.848 |
| Andrews | .346 | .502 | .547 | .623 | .664 | .736 |
| Angelina | .448 | .638 | .740 | .848 | .951 | 1.029 |
| Aransas | .466 | .704 | .796 | .920 | .991 | 1.081 |
| Archer | .423 | .645 | .767 | .928 | 1.069 | 1.149 |
| Armstrong | .383 | .551 | .619 | .716 | .762 | .813 |
| Atascosa | .384 | .569 | .632 | .724 | .771 | .826 |
| Austin | .458 | .641 | .658 | .750 | .766 | .788 |
| Bailey | .369 | .521 | .581 | .665 | .713 | .758 |
| Bandera | .458 | .662 | .709 | .778 | .742 | .813 |
| Bastrop | .470 | .661 | .707 | .764 | .802 | .772 |
| Baylor | .413 | .635 | .751 | .928 | 1.073 | 1.173 |
| Bee | .423 | .645 | .737 | .834 | .886 | .944 |
| Bell | .500 | .656 | .721 | .793 | .747 | .760 |
| Bexar | .426 | .600 | .670 | .712 | .718 | .766 |
| Blanco | .430 | .614 | .694 | .804 | .840 | .932 |
| Borden | .408 | .573 | .657 | .747 | .808 | .914 |
| Bosque | .459 | .625 | .661 | .750 | .723 | .750 |
| Bowie | .480 | .662 | .700 | .735 | .768 | .764 |
| Brazoria | .474 | .688 | .744 | .833 | .942 | .952 |
| Brazos | .472 | .652 | .698 | .722 | .711 | .750 |
| Brewster | .305 | .436 | .488 | .570 | .632 | .698 |
| Briscoe | .385 | .554 | .627 | .731 | .788 | .843 |
| Brooks | .393 | .594 | .655 | .755 | .836 | .893 |
| Brown | .475 | .642 | .691 | .731 | .758 | .813 |
| Burleson | .468 | .651 | .693 | .737 | .724 | .750 |
| Burnet | .431 | .626 | .703 | .777 | .767 | .881 |
| Caldwell | .452 | .645 | .698 | .762 | .784 | .773 |
| Calhoun | .498 | .708 | .806 | .881 | .953 | .994 |
| Callahan | .432 | .623 | .695 | .756 | .813 | .855 |
| Cameron | .386 | .546 | .625 | .712 | .788 | .865 |
| Camp | .476 | .666 | .719 | .747 | .760 | .789 |
| Carson | .371 | .540 | .595 | .677 | .714 | .777 |
| Cass | .479 | .674 | .705 | .771 | .796 | .806 |
| Castro | .372 | .525 | .586 | .673 | .730 | .774 |
| Chambers | .470 | .705 | .783 | .901 | 1.004 | .954 |
| Cherokee | .457 | .656 | .734 | .776 | .823 | .866 |
| Childress | .378 | .568 | .633 | .771 | .862 | .976 |
| Clay | .437 | .657 | .748 | .893 | 1.007 | 1.076 |
| Cochran | .372 | .528 | .598 | .681 | .716 | .763 |

Table 3.4: Countywide values exponent on dimensionless main-channel slope for unified rational method in Texas—Continued

| County name | Exponent κ_T by T -year recurrence interval | | | | | |
|---------------|--|--------|---------|---------|---------|----------|
| | 2 year | 5 year | 10 year | 25 year | 50 year | 100 year |
| Coke | .414 | .613 | .712 | .852 | .945 | 1.029 |
| Coleman | .448 | .623 | .688 | .752 | .804 | .842 |
| Collin | .472 | .671 | .716 | .783 | .758 | .849 |
| Collingsworth | .390 | .551 | .606 | .691 | .729 | .816 |
| Colorado | .469 | .638 | .696 | .744 | .790 | .805 |
| Comal | .443 | .626 | .697 | .758 | .752 | .847 |
| Comanche | .479 | .667 | .703 | .726 | .734 | .797 |
| Concho | .412 | .628 | .702 | .799 | .893 | .934 |
| Cooke | .450 | .655 | .705 | .825 | .793 | .849 |
| Coryell | .485 | .669 | .739 | .742 | .722 | .802 |
| Cottle | .387 | .590 | .681 | .836 | .942 | 1.035 |
| Crane | .330 | .481 | .558 | .643 | .701 | .748 |
| Crockett | .385 | .588 | .691 | .814 | .926 | .981 |
| Crosby | .378 | .586 | .668 | .761 | .827 | .908 |
| Culberson | .322 | .462 | .516 | .584 | .653 | .705 |
| Dallam | .334 | .467 | .530 | .587 | .634 | .677 |
| Dallas | .463 | .692 | .726 | .775 | .766 | .811 |
| Dawson | .385 | .538 | .614 | .692 | .741 | .813 |
| Deaf Smith | .362 | .518 | .577 | .658 | .722 | .780 |
| Delta | .461 | .643 | .703 | .749 | .725 | .838 |
| Denton | .453 | .663 | .692 | .822 | .778 | .825 |
| DeWitt | .459 | .664 | .773 | .768 | .790 | .794 |
| Dickens | .385 | .583 | .674 | .786 | .862 | .984 |
| Dimmit | .322 | .501 | .553 | .659 | .720 | .781 |
| Donley | .386 | .564 | .615 | .711 | .744 | .818 |
| Duval | .383 | .571 | .649 | .739 | .823 | .901 |
| Eastland | .455 | .634 | .693 | .735 | .761 | .804 |
| Ector | .341 | .497 | .561 | .649 | .688 | .742 |
| Edwards | .460 | .668 | .725 | .815 | .805 | .844 |
| Ellis | .461 | .691 | .720 | .795 | .773 | .810 |
| El Paso | .342 | .428 | .484 | .573 | .630 | .689 |
| Erath | .448 | .638 | .678 | .738 | .727 | .760 |
| Falls | .478 | .659 | .665 | .737 | .675 | .698 |
| Fannin | .462 | .646 | .688 | .758 | .745 | .835 |
| Fayette | .477 | .664 | .706 | .737 | .765 | .763 |
| Fisher | .413 | .610 | .708 | .822 | .905 | 1.057 |
| Floyd | .387 | .563 | .643 | .746 | .798 | .874 |
| Foard | .387 | .608 | .702 | .889 | 1.025 | 1.138 |
| Fort Bend | .442 | .640 | .688 | .774 | .855 | .904 |
| Franklin | .472 | .644 | .703 | .740 | .736 | .798 |

Table 3.4: Countywide values exponent on dimensionless main-channel slope for unified rational method in Texas—Continued

| County name | Exponent κ_T by T -year recurrence interval | | | | | |
|-------------|--|--------|---------|---------|---------|----------|
| | 2 year | 5 year | 10 year | 25 year | 50 year | 100 year |
| Freestone | .464 | .692 | .733 | .732 | .731 | .808 |
| Frio | .381 | .552 | .630 | .719 | .774 | .836 |
| Gaines | .348 | .500 | .557 | .640 | .665 | .722 |
| Galveston | .460 | .711 | .774 | .916 | 1.027 | .949 |
| Garza | .392 | .590 | .666 | .758 | .823 | .929 |
| Gillespie | .444 | .635 | .702 | .797 | .827 | .892 |
| Glasscock | .397 | .577 | .656 | .766 | .846 | .954 |
| Goliad | .458 | .689 | .776 | .841 | .899 | .898 |
| Gonzales | .455 | .642 | .735 | .742 | .760 | .759 |
| Gray | .391 | .552 | .600 | .672 | .682 | .760 |
| Grayson | .466 | .649 | .685 | .784 | .774 | .841 |
| Gregg | .465 | .653 | .728 | .774 | .828 | .857 |
| Grimes | .464 | .643 | .704 | .730 | .736 | .752 |
| Guadalupe | .436 | .610 | .683 | .724 | .743 | .771 |
| Hale | .377 | .555 | .630 | .721 | .772 | .825 |
| Hall | .376 | .557 | .634 | .749 | .837 | .922 |
| Hamilton | .463 | .662 | .693 | .725 | .720 | .792 |
| Hansford | .358 | .490 | .546 | .607 | .643 | .686 |
| Hardeman | .381 | .601 | .674 | .879 | .997 | 1.104 |
| Hardin | .457 | .684 | .768 | .828 | .895 | .956 |
| Harris | .445 | .665 | .715 | .807 | .882 | .907 |
| Harrison | .470 | .661 | .728 | .816 | .889 | .943 |
| Hartley | .343 | .485 | .549 | .603 | .661 | .707 |
| Haskell | .403 | .608 | .696 | .861 | .961 | 1.122 |
| Hays | .450 | .639 | .701 | .784 | .803 | .882 |
| Hemphill | .384 | .536 | .584 | .629 | .656 | .717 |
| Henderson | .475 | .701 | .744 | .739 | .749 | .814 |
| Hidalgo | .369 | .550 | .622 | .705 | .796 | .860 |
| Hill | .458 | .669 | .683 | .781 | .752 | .773 |
| Hockley | .393 | .552 | .634 | .706 | .751 | .806 |
| Hood | .430 | .619 | .645 | .763 | .746 | .764 |
| Hopkins | .472 | .655 | .707 | .757 | .724 | .821 |
| Houston | .440 | .631 | .719 | .788 | .816 | .878 |
| Howard | .410 | .574 | .657 | .752 | .824 | .930 |
| Hudspeth | .326 | .473 | .516 | .602 | .668 | .704 |
| Hunt | .479 | .672 | .716 | .773 | .736 | .857 |
| Hutchinson | .380 | .521 | .572 | .641 | .666 | .720 |
| Irion | .393 | .594 | .703 | .858 | .951 | 1.085 |
| Jack | .435 | .621 | .691 | .793 | .832 | .859 |
| Jackson | .497 | .694 | .786 | .844 | .896 | .941 |

Table 3.4: Countywide values exponent on dimensionless main-channel slope for unified rational method in Texas—Continued

| County name | Exponent κ_T by T -year recurrence interval | | | | | |
|-------------|--|--------|---------|---------|---------|----------|
| | 2 year | 5 year | 10 year | 25 year | 50 year | 100 year |
| Jasper | .449 | .652 | .756 | .819 | .922 | 1.007 |
| Jeff Davis | .327 | .442 | .479 | .527 | .592 | .651 |
| Jefferson | .468 | .713 | .796 | .888 | .977 | .973 |
| Jim Hogg | .393 | .568 | .636 | .730 | .814 | .868 |
| Jim Wells | .403 | .620 | .702 | .797 | .871 | .969 |
| Johnson | .432 | .627 | .658 | .788 | .756 | .784 |
| Jones | .407 | .596 | .681 | .805 | .869 | .975 |
| Karnes | .419 | .623 | .713 | .762 | .788 | .794 |
| Kaufman | .478 | .698 | .743 | .765 | .772 | .804 |
| Kendall | .451 | .641 | .697 | .775 | .781 | .890 |
| Kenedy | .406 | .581 | .664 | .753 | .830 | .917 |
| Kent | .399 | .586 | .682 | .774 | .842 | 1.006 |
| Kerr | .476 | .684 | .730 | .802 | .785 | .831 |
| Kimble | .463 | .681 | .732 | .818 | .851 | .908 |
| King | .389 | .608 | .693 | .835 | .911 | 1.060 |
| Kinney | .429 | .621 | .689 | .771 | .773 | .839 |
| Kleberg | .420 | .628 | .712 | .830 | .900 | .989 |
| Knox | .400 | .613 | .712 | .896 | 1.002 | 1.155 |
| Lamar | .451 | .635 | .686 | .746 | .730 | .814 |
| Lamb | .374 | .531 | .601 | .684 | .740 | .784 |
| Lampasas | .445 | .635 | .702 | .744 | .740 | .853 |
| LaSalle | .346 | .503 | .575 | .667 | .729 | .822 |
| Lavaca | .471 | .669 | .762 | .762 | .780 | .803 |
| Lee | .476 | .668 | .706 | .743 | .757 | .781 |
| Leon | .451 | .668 | .732 | .745 | .769 | .835 |
| Liberty | .469 | .685 | .756 | .829 | .900 | .923 |
| Limestone | .461 | .672 | .688 | .711 | .686 | .744 |
| Lipscomb | .383 | .526 | .578 | .616 | .652 | .699 |
| Liveoak | .391 | .574 | .652 | .754 | .820 | .915 |
| Llano | .406 | .608 | .683 | .771 | .808 | .892 |
| Loving | .305 | .442 | .494 | .562 | .615 | .667 |
| Lubbock | .400 | .571 | .658 | .737 | .789 | .853 |
| Lynn | .406 | .564 | .654 | .724 | .789 | .853 |
| Madison | .456 | .643 | .718 | .741 | .770 | .833 |
| Marion | .472 | .671 | .722 | .786 | .839 | .853 |
| Martin | .381 | .532 | .608 | .690 | .741 | .805 |
| Mason | .416 | .649 | .711 | .803 | .846 | .917 |
| Matagorda | .492 | .702 | .774 | .870 | .918 | .993 |
| Maverick | .358 | .535 | .595 | .697 | .756 | .798 |
| McCulloch | .424 | .637 | .690 | .766 | .821 | .901 |

Table 3.4: Countywide values exponent on dimensionless main-channel slope for unified rational method in Texas—Continued

| County name | Exponent κ_T by T -year recurrence interval | | | | | |
|-------------|--|--------|---------|---------|---------|----------|
| | 2 year | 5 year | 10 year | 25 year | 50 year | 100 year |
| McLennan | .505 | .653 | .695 | .769 | .712 | .705 |
| McMullen | .370 | .534 | .603 | .700 | .767 | .844 |
| Medina | .427 | .615 | .670 | .747 | .747 | .805 |
| Menard | .432 | .658 | .717 | .837 | .900 | .981 |
| Midland | .370 | .535 | .610 | .697 | .754 | .817 |
| Milam | .476 | .657 | .690 | .763 | .741 | .772 |
| Mills | .451 | .620 | .668 | .711 | .745 | .835 |
| Mitchell | .408 | .591 | .682 | .794 | .899 | 1.041 |
| Montague | .450 | .653 | .723 | .828 | .834 | .897 |
| Montgomery | .461 | .651 | .709 | .753 | .787 | .819 |
| Moore | .359 | .509 | .567 | .635 | .671 | .719 |
| Morris | .478 | .663 | .710 | .751 | .773 | .786 |
| Motley | .378 | .577 | .658 | .784 | .867 | .975 |
| Nacogdoches | .456 | .671 | .754 | .889 | .975 | 1.068 |
| Navarro | .478 | .709 | .741 | .759 | .754 | .803 |
| Newton | .443 | .649 | .753 | .817 | .930 | .989 |
| Nolan | .411 | .628 | .725 | .843 | .943 | 1.073 |
| Nueces | .435 | .655 | .746 | .876 | .946 | 1.054 |
| Ochiltree | .365 | .525 | .564 | .617 | .656 | .703 |
| Oldham | .359 | .516 | .576 | .652 | .708 | .769 |
| Orange | .477 | .697 | .800 | .847 | .930 | .974 |
| Palo Pinto | .444 | .620 | .680 | .754 | .775 | .794 |
| Panola | .457 | .677 | .753 | .890 | .986 | 1.079 |
| Parker | .442 | .621 | .659 | .782 | .777 | .792 |
| Parmer | .349 | .502 | .563 | .633 | .695 | .738 |
| Pecos | .334 | .485 | .568 | .658 | .724 | .765 |
| Polk | .453 | .654 | .739 | .799 | .874 | .927 |
| Potter | .380 | .542 | .600 | .683 | .725 | .788 |
| Presidio | .294 | .421 | .484 | .549 | .619 | .673 |
| Rains | .482 | .682 | .722 | .754 | .724 | .809 |
| Randall | .379 | .545 | .606 | .694 | .745 | .796 |
| Reagan | .377 | .572 | .659 | .778 | .888 | .986 |
| Real | .479 | .680 | .730 | .803 | .769 | .800 |
| Red River | .457 | .631 | .689 | .727 | .736 | .780 |
| Reeves | .311 | .445 | .490 | .556 | .617 | .672 |
| Refugio | .471 | .711 | .799 | .901 | .959 | 1.015 |
| Roberts | .369 | .517 | .572 | .636 | .661 | .726 |
| Robertson | .462 | .660 | .692 | .713 | .697 | .752 |
| Rockwall | .477 | .687 | .734 | .775 | .754 | .835 |
| Runnels | .421 | .615 | .694 | .789 | .881 | .894 |

Table 3.4: Countywide values exponent on dimensionless main-channel slope for unified rational method in Texas—Continued

| County name | Exponent κ_T by T -year recurrence interval | | | | | |
|---------------|--|--------|---------|---------|---------|----------|
| | 2 year | 5 year | 10 year | 25 year | 50 year | 100 year |
| Rusk | .463 | .665 | .744 | .827 | .903 | .950 |
| Sabine | .434 | .624 | .728 | .863 | .990 | 1.071 |
| San Augustine | .438 | .640 | .754 | .873 | 1.016 | 1.095 |
| San Jacinto | .464 | .657 | .734 | .777 | .825 | .867 |
| San Patricio | .433 | .661 | .750 | .876 | .954 | 1.065 |
| San Saba | .411 | .632 | .681 | .738 | .769 | .884 |
| Schleicher | .412 | .640 | .721 | .870 | .954 | 1.086 |
| Scurry | .414 | .593 | .670 | .779 | .866 | 1.019 |
| Shackelford | .415 | .618 | .695 | .797 | .862 | .941 |
| Shelby | .452 | .665 | .777 | .917 | 1.033 | 1.095 |
| Sherman | .351 | .492 | .543 | .605 | .646 | .690 |
| Smith | .479 | .663 | .713 | .735 | .768 | .807 |
| Somervell | .429 | .613 | .638 | .757 | .731 | .751 |
| Starr | .371 | .535 | .597 | .691 | .782 | .835 |
| Stephens | .435 | .632 | .701 | .760 | .794 | .869 |
| Sterling | .401 | .593 | .694 | .809 | .936 | 1.039 |
| Stonewall | .405 | .602 | .690 | .822 | .886 | 1.051 |
| Sutton | .439 | .650 | .729 | .847 | .918 | 1.048 |
| Swisher | .379 | .557 | .617 | .719 | .764 | .811 |
| Tarrant | .436 | .644 | .679 | .814 | .766 | .798 |
| Taylor | .420 | .624 | .703 | .808 | .858 | .915 |
| Terrell | .351 | .549 | .664 | .755 | .854 | .893 |
| Terry | .374 | .534 | .618 | .691 | .729 | .782 |
| Throckmorton | .422 | .626 | .733 | .861 | .972 | 1.121 |
| Titus | .473 | .652 | .702 | .744 | .752 | .779 |
| Tom Green | .393 | .601 | .700 | .817 | .909 | .996 |
| Travis | .453 | .638 | .690 | .797 | .806 | .873 |
| Trinity | .446 | .638 | .732 | .814 | .860 | .921 |
| Tyler | .444 | .643 | .747 | .817 | .897 | .986 |
| Upshur | .480 | .656 | .713 | .751 | .778 | .801 |
| Upton | .368 | .533 | .606 | .722 | .778 | .834 |
| Uvalde | .426 | .629 | .683 | .756 | .768 | .834 |
| Val Verde | .421 | .636 | .734 | .821 | .858 | .932 |
| Van Zandt | .482 | .696 | .730 | .744 | .752 | .799 |
| Victoria | .487 | .699 | .792 | .840 | .907 | .929 |
| Walker | .458 | .639 | .725 | .753 | .785 | .822 |
| Waller | .451 | .636 | .673 | .752 | .780 | .834 |
| Ward | .330 | .449 | .506 | .587 | .637 | .690 |
| Washington | .472 | .646 | .674 | .747 | .738 | .743 |
| Webb | .355 | .532 | .606 | .698 | .774 | .847 |

Table 3.5: Comparison of annual peak streamflow frequency estimates for the Dickens county example.

[cfs, cubic feet per second]

| Recurrence interval (years) | OmegaEM peak streamflow (cfs) | Unified Rational Method | | |
|--------------------------------|----------------------------------|------------------------------------|---------------------------------------|------------------------------------|
| | | Lower estimate Q_L^* (cfs) | Best estimate \bar{Q}^* (cfs) | Upper estimate Q_U^* (cfs) |
| | | 2 | 7.30 | 3.39 |
| 5 | 8.34 | 4.90 | 7.44 | 9.74 |
| 10 | 9.70 | 5.87 | 8.89 | 11.7 |
| 25 | 10.2 | 7.44 | 11.2 | 14.5 |
| 50 | 10.5 | 8.77 | 13.2 | 16.9 |
| 100 | 10.9 | 10.3 | 15.4 | 19.5 |

Table 3.4: Countywide values exponent on dimensionless main-channel slope for unified rational method in Texas—Continued

| County name | Exponent κ_T by T -year recurrence interval | | | | | |
|-------------|--|--------|---------|---------|---------|----------|
| | 2 year | 5 year | 10 year | 25 year | 50 year | 100 year |
| Wharton | .477 | .662 | .735 | .794 | .842 | .889 |
| Wheeler | .389 | .545 | .600 | .654 | .676 | .751 |
| Wichita | .414 | .652 | .756 | .950 | 1.077 | 1.175 |
| Wilbarger | .406 | .634 | .734 | .918 | 1.073 | 1.150 |
| Willacy | .384 | .544 | .631 | .726 | .794 | .892 |
| Williamson | .478 | .652 | .703 | .828 | .793 | .859 |
| Wilson | .417 | .596 | .681 | .719 | .747 | .755 |
| Winkler | .332 | .478 | .540 | .619 | .664 | .708 |
| Wise | .444 | .624 | .683 | .832 | .800 | .825 |
| Wood | .480 | .668 | .711 | .734 | .729 | .779 |
| Yoakum | .369 | .517 | .585 | .669 | .693 | .743 |
| Young | .430 | .640 | .729 | .820 | .910 | .981 |
| Zapata | .359 | .534 | .609 | .699 | .779 | .846 |
| Zavala | .364 | .535 | .614 | .711 | .782 | .838 |

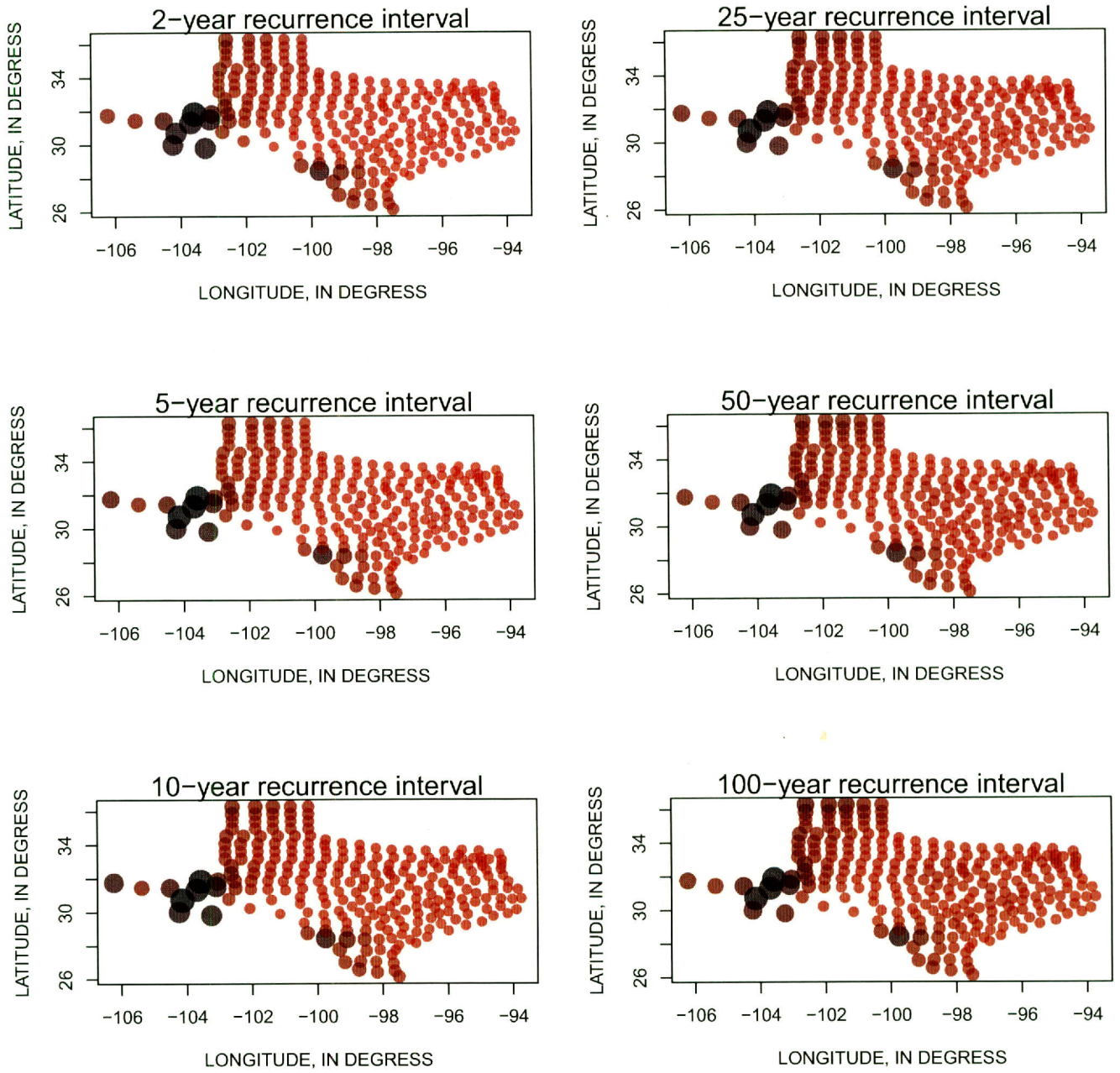

Figure 3.1: Intercept of regression by county for unified rational method in Texas. Increasing size and hue towards black indicates relatively higher values.

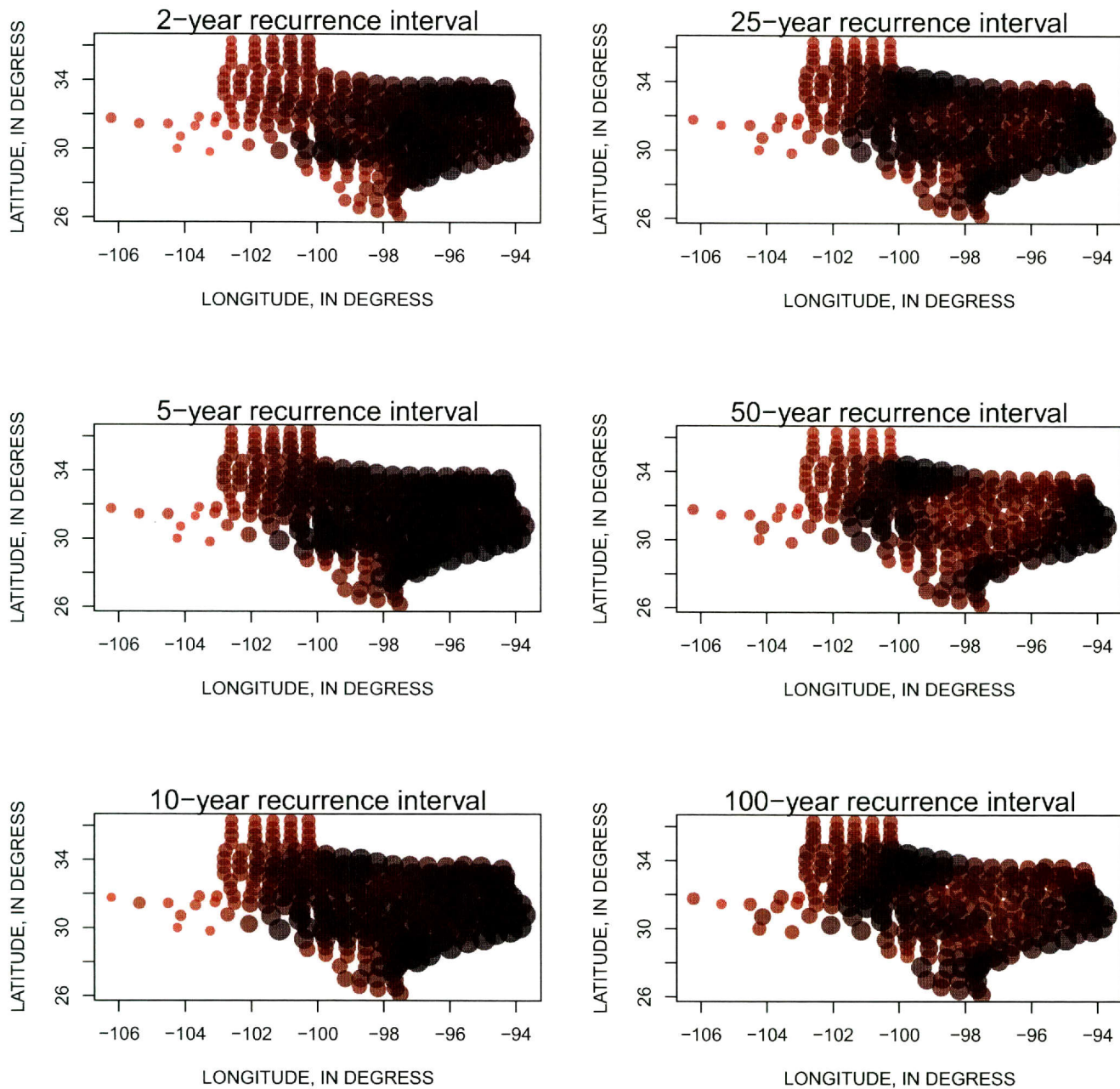

Figure 3.2: Exponent on drainage area for unified rational method in Texas. Increasing size and hue towards black indicates relatively higher values.

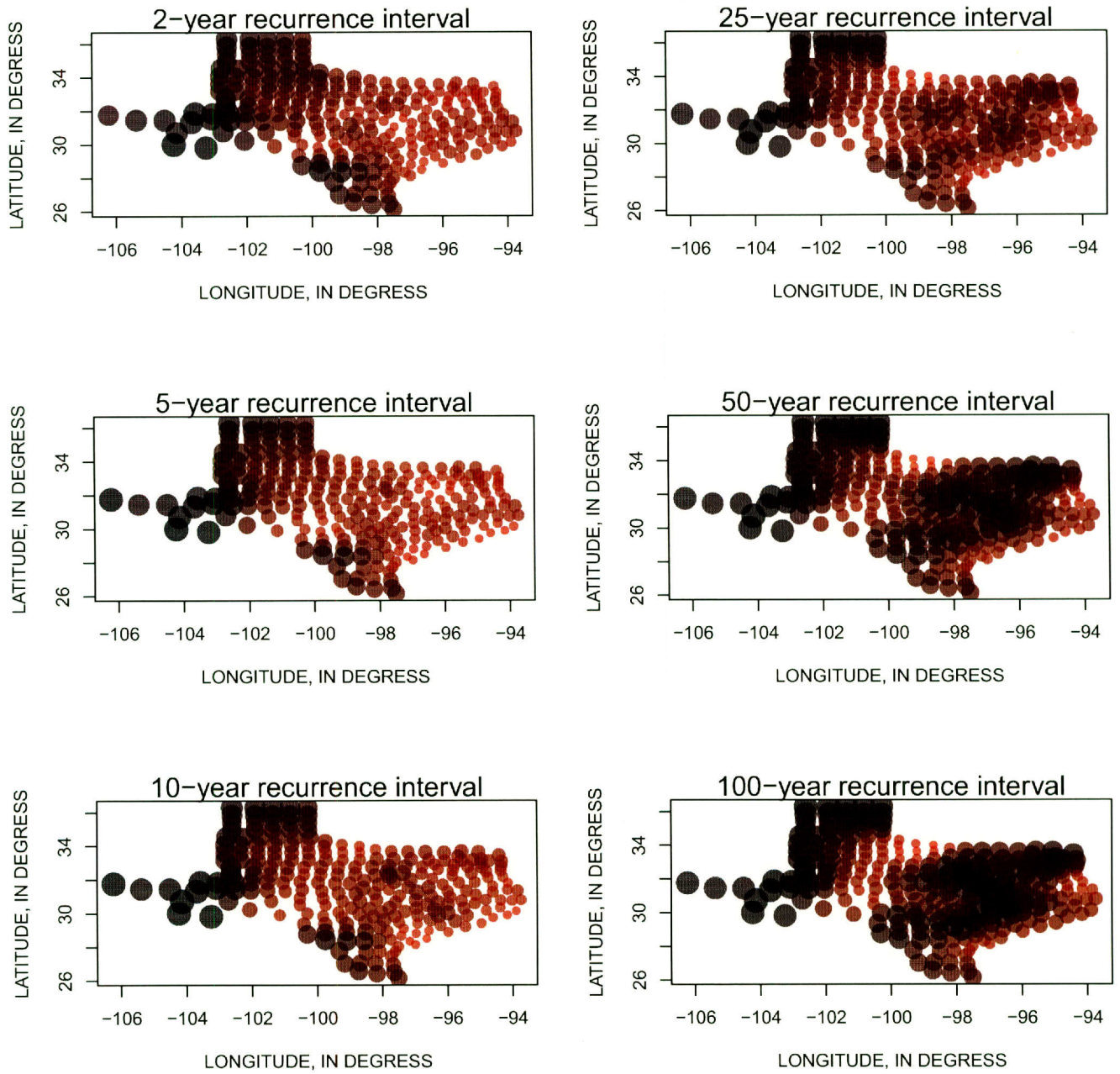

Figure 3.3: Exponent on dimensionless main-channel slope for unified rational method in Texas. Increasing size and hue towards black indicates relatively higher values.

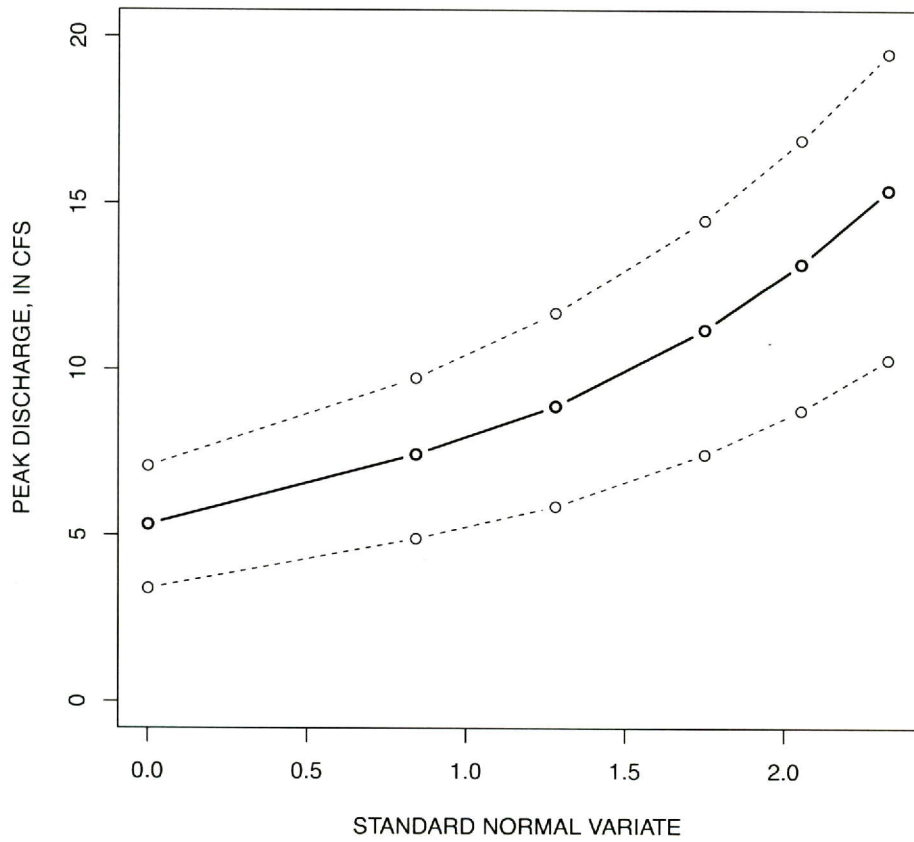

Figure 3.4: Estimated peak discharge frequency curves of Unified Rational Method for Texas for the Dickens county example. The thick line represents the \bar{Q}^* and is considered the best estimate of the peak-streamflow frequency curve. The dashed lines represent the upper and lower boundaries of the estimate by Q_U^* and Q_L^* , respectively.

4. EXAMPLE APPLICATIONS

The purpose of this chapter is to present an illustrative application of results from the variety of tasks undertaken as part of this research project.

4.1. Example Application for Peak Discharge Estimation (Forward Modeling)

An illustrative example is presented to demonstrate an application of the conventional rational method and the URAT method. Figure 4.1 is a subdivision that drains into a conveyance that is to flow underneath a highway, a development situation common to Texas. The portion of flow that is derived from the subdivision is the subject of this example. The culvert location is indicated at the top of the figure. The solid black line at the bottom of the figure represents a distance of 903 feet¹.

4.1.1. Using a Conventional Rational Method

1. Determine the drainage area. In Figure 4.1 the drainage area is 20 acres.
2. Determine the time of concentration. The figure depicts a short “overland flow” component (A_2 to B_2), then shallow concentrated flow in the street (B_2 to C_2), and then open channel flow in an 18-inch concrete storm sewer (C_2 to D_2), and finally open channel flow in a vegetated swale (D_2 to the culvert). Regardless of method, the analyst will generally estimate travel times in different components, then sum the times. Additionally, the analyst is expected to try several paths and choose the path that produces the longest time.
 - (a) Overland flow component. Dense grass, slope = 0.005. Using Figure 5-4 of the 2009 TxDOT hydraulic manual, a travel speed for this component is 0.5 feet/second. The distance on the map is roughly 150 feet, for a travel time of 5 minutes.
 - (b) Shallow concentrated flow component. The surface is paved, slope = 0.005. The travel speed for the roughly 150 feet using Figure 5-4 of the 2009 TxDOT hydraulic manual is 1.5 feet/second, for a travel time of 1.67 minutes.

¹This drawing is adapted from the Iowa Stormwater Management Manual. In that manual, the drawing is not dimensioned. The approximate dimensioning was used by report authors to estimate travel distances for conventional rational method application. The drawing itself was used by report authors to infer fraction of drainage area that is functionally impervious as ratios of total area (as reported in the Iowa manual).

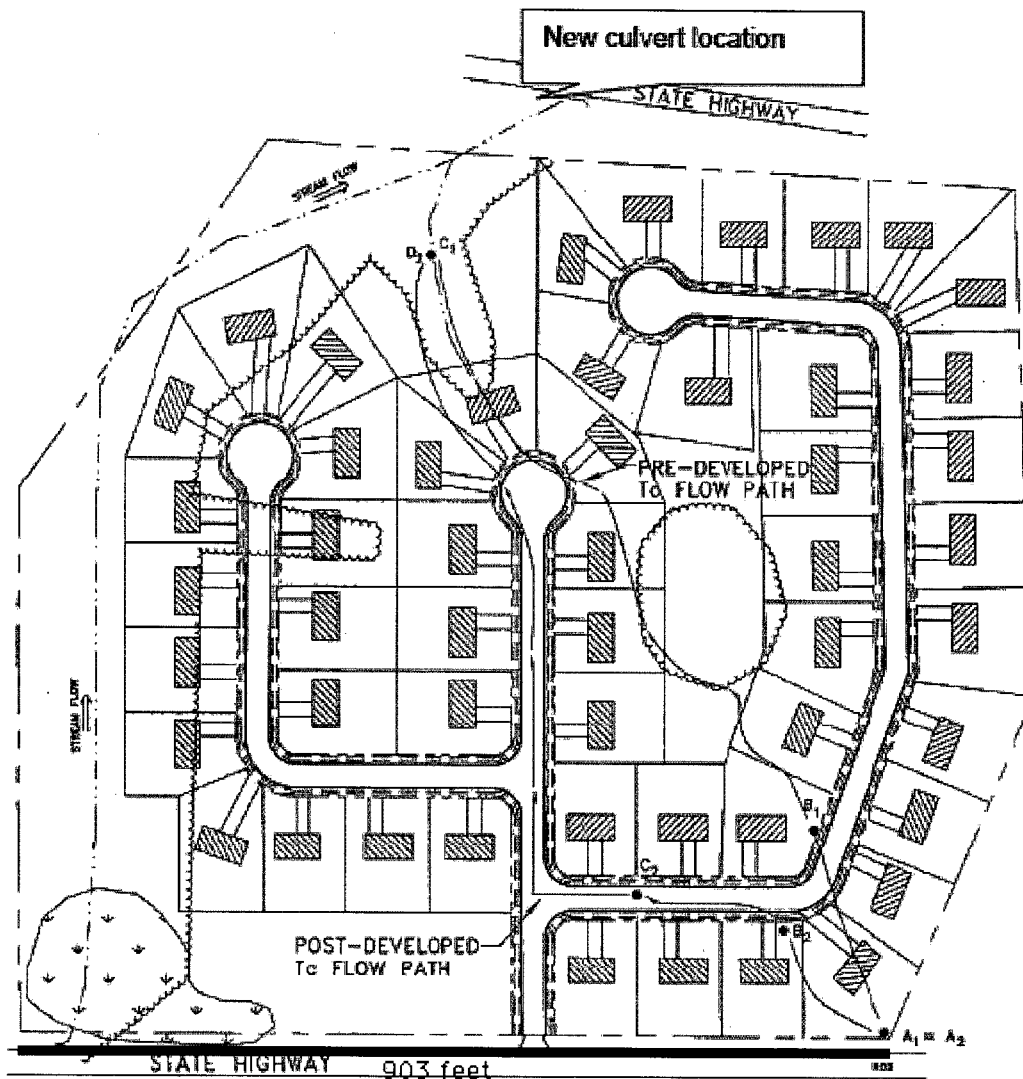

Figure 4.1: Subdivision X Drainage to a Highway Culvert

- (c) Open channel flow component — storm sewer. The sewer is an 18-inch concrete sewer laid on a slope of 0.01, the Manning's roughness coefficient is selected as 0.015. We will assume the sewer will operate at 3/4 full for the purpose of the example. The hydraulic radius for this segment is 0.374 feet. Manning's equation to estimate travel velocity is $V = \frac{1.49}{n} R_h^{2/3} S_0^{1/2}$. In this example, the velocity is $V = \frac{1.49}{0.015} (0.374)^{2/3} (0.01)^{1/2} = 5.15$ feet/second. The sewer is about 800 feet long, for a travel time of 2.58 minutes.
- (d) Open channel flow component — vegetated swale. The swale is assumed to be an 8-foot wide trapezoidal channel with 4:1 side slope, and longitudinal slope of 0.01. Assuming a flow depth of about 0.6 feet in the swale, the hydraulic radius is 0.653 feet. In this

example, the velocity is $V = \frac{1.49}{0.035} (0.653)^{2/3} (0.01)^{1/2} = 3.20$ feet/second. The swale is about 300 feet long, for a travel time of 1.56 minutes.

- (e) T_c estimate as sum of individual component times. In this example the sum of the travel times is $5.0 + 1.67 + 2.58 + 1.56 = 10.81$ minutes.
3. Verify the method application is appropriate with the stated assumptions in the design manual (particularly storage and watershed size). In this example there is no implied storage, and the watershed size is well within the conventional use guideline.
 4. Determine rainfall depth values for desired design frequency, project location, and storm duration. Suppose for this example the subdivision is located in Harris County, and we are concerned with the 4 percent chance (25-year) runoff from this subdivision. The rainfall depth is determined from Asquith and Roussel (2004).
 - (a) The T_c for this example is 10.81 minutes, which is a smaller time value than the smallest time value mapped in Asquith and Roussel (2004), thus extrapolation is required. An extrapolation technique is to plot several values of depth and duration for a prescribed frequency on log-log graph and extend the relationship to the desired time value².
 - (b) Figure 4.2 is such a plot for this example. In the figure, the duration and depth information for Harris County are shown to the right of the log-log plot. These values are taken from the maps in Asquith and Roussel (2004). The values are plotted as solid markers. A dashed line is passed through these markers, this line is strictly a “visual” fit.
 - (c) The desired duration is located on the horizontal axis, in this example, 10.81 minutes is selected. The designer then projects a segment upward to the extrapolated (dashed) line.
 - (d) From the intersection of the upward segment and the extrapolated line, the designer then extends a horizontal line from the intersection to the depth axis and reads the corresponding depth value. In this case, the value is ≈ 1.5 inches.
 5. Compute rainfall intensity. Intensity is computed from the depth and duration value. In this example, the intensity is $\frac{1.5 \text{ inches}}{10 \text{ minutes}} \frac{60 \text{ minutes}}{1 \text{ hour}} = 9.0$ inches/hour.
 6. Select runoff coefficients. This step requires proportioning the map (if composite numbers are to be used) or some judgement of the type of area being examined. In this example, the subdivision is clearly a residential subdivision and the middle of the range for such a land use from a typical tabulation (e.g., Table A.1) would be reasonable, $C = 0.4$. Alternatively, additional information such as knowledge that 80 percent of the drainage area is actually residential, and 20 percent of the drainage area is grass/common area could be used to establish a composite runoff coefficient (also selecting values from Table A.1) such as $C = 0.8 \times 0.4 + 0.2 \times 0.25 = 0.37$. The composite value is used in the remainder of this example, but any defensible approach (tabular land use, or tabular composite) is anticipated to produce essentially similar values.

²Extension to less than 10 minutes is not suggested, although some municipal drainage manuals do provide guidance for durations as small as 5 minutes.

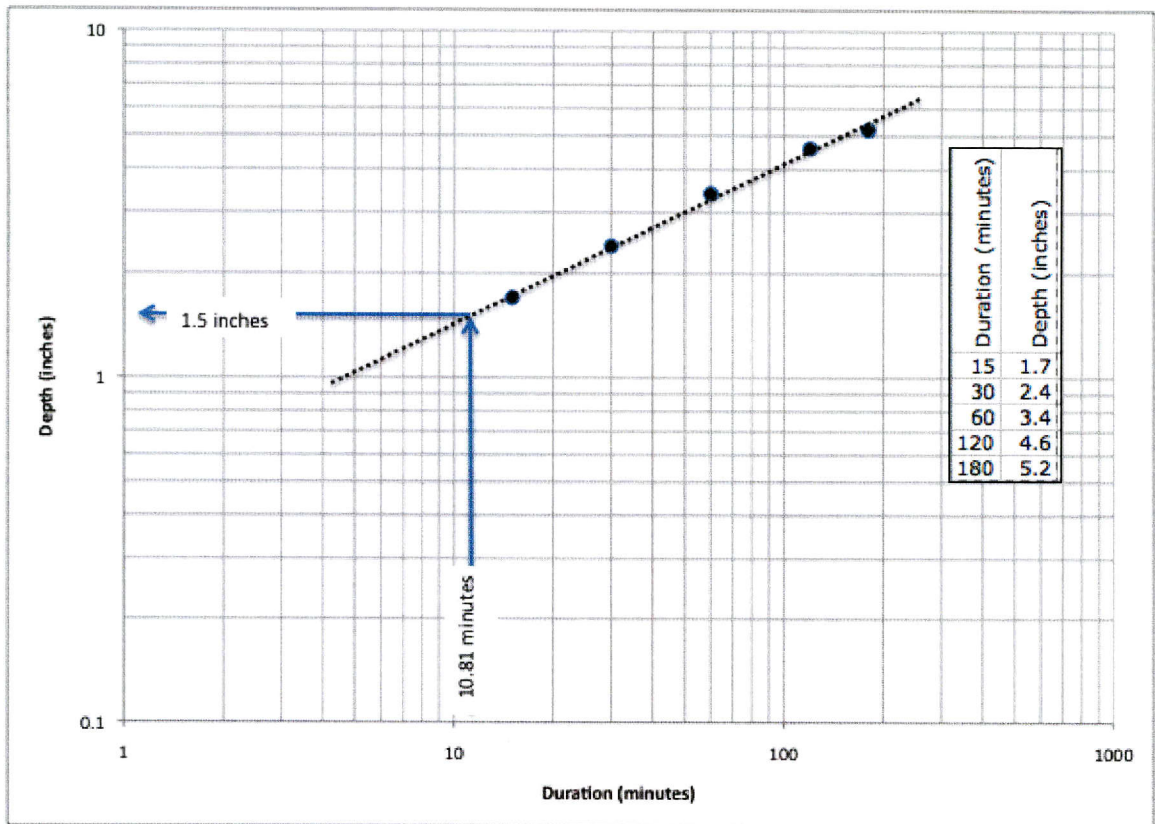

Figure 4.2: Depth-Duration diagram for Harris County for the application example. Values are from maps in Asquith and Roussel (2004). Dashed line is used to extrapolate mapped values to unmapped durations.

7. Calculate estimated peak discharge. This step is the actual application of the rational equation.

$$Q_p = 0.37 \times 9.0 \times 20 = 66.6 \text{ cfs}$$

4.1.2. Using the Unified Rational Method for Texas

1. Determine drainage area; determine proportion that is (or will be) functionally impervious. In Figure 4.1 the drainage area is 20 acres, the area of the 51 home footprints, driveways, streets, and cul-de-sacs is about 4.57 acres. The remaining area is comprised of yards and other open areas. The overall slope of the drainage area to the outlet is also required, in this example the arithmetic mean value of the surface slopes and the sewer slopes are used ($S = 0.0075$), but any reasonable, defensible value for the representative slope would suffice.
2. Find values for α_T , β_T , κ_T from Tables 3.3, 3.2, and 3.4. The values for this example for Harris County are $\alpha_{25} = 0.229$, $\beta_{25} = 0.075$, and $\kappa_{25} = 0.807$.
3. Compute $T^* = \beta_{25} \times A^{\alpha_{25}} \times S^{-\kappa_{25}}$. The value for the example is $T^* = 0.075 \times 20^{0.229} \times$

$0.0075^{-0.807} = 7.7$ minutes. The URAT method authors suggest that values smaller than 10 minutes are truncated to 10 minutes and used in such instances, thus 10 minutes will be used in the next steps for this example.

4. Compute I^* using T^* and Asquith and Roussel (2004). As in the conventional example, extrapolation is required and the same extrapolation procedure would be applied. The extrapolated depth at 10 minutes is ≈ 1.44 inches. The resulting values for this example are $I^* = 1.4/\frac{10}{60} = 8.4$ inches per hour.
5. Compute $C^* = 0.15 + 0.85 \times IMP$. The value for the example is $C^* = 0.15 + 0.85 \times \frac{4.57}{20} = 0.34$.
6. Compute $Q_p = C^* I^* A$. The value for the example is $Q_p = (0.34) \times (8.4) \times 20 = 57.1$ cfs.

4.1.3. Comparison and Contrast of the Two Methods

As a comparison of the two methods, the results differ by less than 15 percent, and the URAT result is known to adhere to the requisite runoff probability. That is, the URAT result is an estimate of the 4-percent chance runoff. The effort in the conventional method in determining the time of concentration from distance and velocity estimates is exchanged for the effort in determining T^* from a regression equation involving three tables. The effort in computation of intensity is equal using Asquith and Roussel (2004). The effort in composite runoff coefficients and some judgement of land use is exchanged for the effort in determining the fraction of functionally impervious cover over a contributing area.

4.2. Application of the Modified Rational Method Parameterized by the Unified Rational Method

Extending the example above, suppose that a hydrograph estimate is desired from the drainage area instead of just a peak flow estimate. The watershed characteristics already determined are used to parameterize the modified rational method hydrograph.

The modified rational method will require the drainage area, characteristic time, and the runoff coefficient; these are already computed from the previous example. In addition a hyetograph is convenient to apply the MRM as a special-case unit hydrograph computation. The hyetograph can either be a uniform hyetograph or non-uniform. The uniform hyetograph can be applied for a duration less than, equal to, or greater than the characteristic time.

To simulate a hydrograph from the example watershed the analyst generates a time series of rainfall at an appropriate time step which should be less than the characteristic time. In this example 5 minutes is chosen as appropriate. One-minute would work; a time step greater than the characteristic time would cause aliasing (a kind of error) of the response. This time series will become the input hyetograph. This time series can contain zeroes. We will call this time series $P(t)$.

From the hyetograph $P(t)$, construct the excess hyetograph as the product of $P(t)$ and the runoff

coefficient C as in Equation 4.1. We will call this time series $XS(t)$.

$$XS(t) = C \times P(t) \quad (4.1)$$

From the URAT coefficients, the analyst then constructs a kernel function $f(t)$ from Equation 4.2.

$$f(t) = \begin{cases} 0 & \text{for } t \leq 0 \\ \frac{1}{T^*} & \text{for } 0 < t \leq T^* \\ 0 & \text{for } t > T^* \end{cases} \quad (4.2)$$

The kernel function is then normalized so that it integrates to unity (e.g. sum the values, then divide each value by the sum) as in Equation 4.3.

$$u(t) = \frac{f(t)}{\int_0^{\infty} f(\tau) d\tau} \quad (4.3)$$

The normalized kernel $u(t)$ is a modified rational method unit hydrograph for the particular area. Next the analyst computes the response from the value in the input hyetograph at time τ as the product of the normalized kernel and the excess rainfall rate associated with that input as in Equation 4.4.

$$q(t, \tau) = XS(\tau) \times u(t - \tau) \quad (4.4)$$

These responses are added together (convolved) and multiplied by the drainage area to produce the total response from the drainage area as in Equation 4.5

$$Q(t) = \text{Area} \times \sum_0^{\tau} q(t, \tau) \quad (4.5)$$

Figure 4.3 illustrates these various computational steps. The drainage area parameters are estimated using the URAT procedure already examined and appear at the top of the worksheet for use in other computations.

The time series of rainfall input appears in the figure as the fifth and sixth rows in the worksheet. In this example 85 minutes of rainfall are considered. The choice of 85 minutes is arbitrary to illustrate the method, a time series long enough to have substantial portions of zero rainfall was desired in the illustration to accommodate different input hyetographs. Furthermore, time need not begin at $t = 0$ minutes for the MRM to function.

$P(t)$ is constructed as follows; at $t = 0$ minutes rainfall begins at intensity 8.4 inches per hour and proceeds for ten minutes, at $t = 10$ minutes rainfall begins at intensity 0 inches per hour and continue at this rate for the remainder of the time series. The associated start times are in the fifth row of the worksheet, and the associated start intensities are the sixth row of the worksheet. The method assumes that the intensity is maintained at a constant value for each time increment (hence the choice of time interval is not trivial). The rainfall excess $XS(t)$ is computed by Equation 4.1 and is the seventh row of the worksheet.

| | A | B | C | D | E | F | G | H | I | J | K | L | M | N | O | P | Q | R | S | T | U | V | |
|----|----------------------------|----------|---|-----|-----|-----|-----|-----|-----|-----|-----|-----|-----|-----|-----|-----|-----|-----|-----|-----|-----|------|-----------------|
| 1 | 0-6070 MRM Example - 1 | | | | | | | | | | | | | | | | | | | | | | |
| 2 | Area: 20 acres | | | | | | | | | | | | | | | | | | | | | | |
| 3 | Tc: 10.0 minutes | | | | | | | | | | | | | | | | | | | | | | |
| 4 | C: 0.34 runoff-coefficient | | | | | | | | | | | | | | | | | | | | | | |
| 5 | Time (minutes) | 0 | 5 | 10 | 15 | 20 | 25 | 30 | 35 | 40 | 45 | 50 | 55 | 60 | 65 | 70 | 75 | 80 | 85 | | | | |
| 6 | Intensity (in/hr) | 8.4 | 8.4 | 0 | 0 | 0 | 0 | 0 | 0 | 0 | 0 | 0 | 0 | 0 | 0 | 0 | 0 | 0 | 0 | 0 | 0 | 0 | |
| 7 | Excess (in/hr) | 2.9 | 2.9 | 0 | 0 | 0 | 0 | 0 | 0 | 0 | 0 | 0 | 0 | 0 | 0 | 0 | 0 | 0 | 0 | 0 | 0 | 0 | |
| 8 | Time | Kernel | Kernel Function, shifted for each time | | | | | | | | | | | | | | | | | | | | |
| 9 | 0 | 0 | 0 | 0 | 0 | 0 | 0 | 0 | 0 | 0 | 0 | 0 | 0 | 0 | 0 | 0 | 0 | 0 | 0 | 0 | 0 | 0 | |
| 10 | 5 | 0.1 | 0 | 0 | 0 | 0 | 0 | 0 | 0 | 0 | 0 | 0 | 0 | 0 | 0 | 0 | 0 | 0 | 0 | 0 | 0 | 0 | |
| 11 | 10 | 0.1 | 0.1 | 0 | 0 | 0 | 0 | 0 | 0 | 0 | 0 | 0 | 0 | 0 | 0 | 0 | 0 | 0 | 0 | 0 | 0 | 0 | |
| 12 | 15 | 0 | 0.1 | 0.1 | 0 | 0 | 0 | 0 | 0 | 0 | 0 | 0 | 0 | 0 | 0 | 0 | 0 | 0 | 0 | 0 | 0 | 0 | |
| 13 | 20 | 0 | 0 | 0.1 | 0.1 | 0 | 0 | 0 | 0 | 0 | 0 | 0 | 0 | 0 | 0 | 0 | 0 | 0 | 0 | 0 | 0 | 0 | |
| 14 | 25 | 0 | 0 | 0 | 0.1 | 0.1 | 0 | 0 | 0 | 0 | 0 | 0 | 0 | 0 | 0 | 0 | 0 | 0 | 0 | 0 | 0 | 0 | |
| 15 | 30 | 0 | 0 | 0 | 0 | 0.1 | 0.1 | 0 | 0 | 0 | 0 | 0 | 0 | 0 | 0 | 0 | 0 | 0 | 0 | 0 | 0 | 0 | |
| 16 | 35 | 0 | 0 | 0 | 0 | 0 | 0.1 | 0.1 | 0 | 0 | 0 | 0 | 0 | 0 | 0 | 0 | 0 | 0 | 0 | 0 | 0 | 0 | |
| 17 | 40 | 0 | 0 | 0 | 0 | 0 | 0 | 0.1 | 0.1 | 0 | 0 | 0 | 0 | 0 | 0 | 0 | 0 | 0 | 0 | 0 | 0 | 0 | |
| 18 | 45 | 0 | 0 | 0 | 0 | 0 | 0 | 0 | 0.1 | 0.1 | 0 | 0 | 0 | 0 | 0 | 0 | 0 | 0 | 0 | 0 | 0 | 0 | |
| 19 | 50 | 0 | 0 | 0 | 0 | 0 | 0 | 0 | 0 | 0.1 | 0.1 | 0 | 0 | 0 | 0 | 0 | 0 | 0 | 0 | 0 | 0 | 0 | |
| 20 | 55 | 0 | 0 | 0 | 0 | 0 | 0 | 0 | 0 | 0 | 0.1 | 0.1 | 0 | 0 | 0 | 0 | 0 | 0 | 0 | 0 | 0 | 0 | |
| 21 | 60 | 0 | 0 | 0 | 0 | 0 | 0 | 0 | 0 | 0 | 0 | 0.1 | 0.1 | 0 | 0 | 0 | 0 | 0 | 0 | 0 | 0 | 0 | |
| 22 | 65 | 0 | 0 | 0 | 0 | 0 | 0 | 0 | 0 | 0 | 0 | 0 | 0 | 0.1 | 0.1 | 0 | 0 | 0 | 0 | 0 | 0 | 0 | |
| 23 | 70 | 0 | 0 | 0 | 0 | 0 | 0 | 0 | 0 | 0 | 0 | 0 | 0 | 0 | 0.1 | 0.1 | 0 | 0 | 0 | 0 | 0 | 0 | |
| 24 | 75 | 0 | 0 | 0 | 0 | 0 | 0 | 0 | 0 | 0 | 0 | 0 | 0 | 0 | 0 | 0.1 | 0.1 | 0 | 0 | 0 | 0 | 0 | |
| 25 | 80 | 0 | 0 | 0 | 0 | 0 | 0 | 0 | 0 | 0 | 0 | 0 | 0 | 0 | 0 | 0 | 0.1 | 0.1 | 0 | 0 | 0 | 0 | |
| 26 | 85 | 0 | 0 | 0 | 0 | 0 | 0 | 0 | 0 | 0 | 0 | 0 | 0 | 0 | 0 | 0 | 0 | 0.1 | 0.1 | 0 | 0 | 0 | |
| 27 | SUM | 0.2 | 0.2 | 0.2 | 0.2 | 0.2 | 0.2 | 0.2 | 0.2 | 0.2 | 0.2 | 0.2 | 0.2 | 0.2 | 0.2 | 0.2 | 0.2 | 0.2 | 0.2 | 0.1 | 0.1 | 0 | |
| 28 | Time | Response | Response Function; Each column is product of Excess and Kernel divided by the Normalization Constant. | | | | | | | | | | | | | | | | | | | | Discharge (cfs) |
| 29 | 0 | 0 | 0 | 0 | 0 | 0 | 0 | 0 | 0 | 0 | 0 | 0 | 0 | 0 | 0 | 0 | 0 | 0 | 0 | 0 | 0 | 0 | |
| 30 | 5 | 1.4 | 0 | 0 | 0 | 0 | 0 | 0 | 0 | 0 | 0 | 0 | 0 | 0 | 0 | 0 | 0 | 0 | 0 | 0 | 0 | 28.6 | |
| 31 | 10 | 1.4 | 1.4 | 0 | 0 | 0 | 0 | 0 | 0 | 0 | 0 | 0 | 0 | 0 | 0 | 0 | 0 | 0 | 0 | 0 | 0 | 57 | |
| 32 | 15 | 0 | 1.4 | 0 | 0 | 0 | 0 | 0 | 0 | 0 | 0 | 0 | 0 | 0 | 0 | 0 | 0 | 0 | 0 | 0 | 0 | 28.6 | |
| 33 | 20 | 0 | 0 | 0 | 0 | 0 | 0 | 0 | 0 | 0 | 0 | 0 | 0 | 0 | 0 | 0 | 0 | 0 | 0 | 0 | 0 | 0 | |
| 34 | 25 | 0 | 0 | 0 | 0 | 0 | 0 | 0 | 0 | 0 | 0 | 0 | 0 | 0 | 0 | 0 | 0 | 0 | 0 | 0 | 0 | 0 | |
| 35 | 30 | 0 | 0 | 0 | 0 | 0 | 0 | 0 | 0 | 0 | 0 | 0 | 0 | 0 | 0 | 0 | 0 | 0 | 0 | 0 | 0 | 0 | |
| 36 | 35 | 0 | 0 | 0 | 0 | 0 | 0 | 0 | 0 | 0 | 0 | 0 | 0 | 0 | 0 | 0 | 0 | 0 | 0 | 0 | 0 | 0 | |
| 37 | 40 | 0 | 0 | 0 | 0 | 0 | 0 | 0 | 0 | 0 | 0 | 0 | 0 | 0 | 0 | 0 | 0 | 0 | 0 | 0 | 0 | 0 | |
| 38 | 45 | 0 | 0 | 0 | 0 | 0 | 0 | 0 | 0 | 0 | 0 | 0 | 0 | 0 | 0 | 0 | 0 | 0 | 0 | 0 | 0 | 0 | |
| 39 | 50 | 0 | 0 | 0 | 0 | 0 | 0 | 0 | 0 | 0 | 0 | 0 | 0 | 0 | 0 | 0 | 0 | 0 | 0 | 0 | 0 | 0 | |
| 40 | 55 | 0 | 0 | 0 | 0 | 0 | 0 | 0 | 0 | 0 | 0 | 0 | 0 | 0 | 0 | 0 | 0 | 0 | 0 | 0 | 0 | 0 | |
| 41 | 60 | 0 | 0 | 0 | 0 | 0 | 0 | 0 | 0 | 0 | 0 | 0 | 0 | 0 | 0 | 0 | 0 | 0 | 0 | 0 | 0 | 0 | |
| 42 | 65 | 0 | 0 | 0 | 0 | 0 | 0 | 0 | 0 | 0 | 0 | 0 | 0 | 0 | 0 | 0 | 0 | 0 | 0 | 0 | 0 | 0 | |
| 43 | 70 | 0 | 0 | 0 | 0 | 0 | 0 | 0 | 0 | 0 | 0 | 0 | 0 | 0 | 0 | 0 | 0 | 0 | 0 | 0 | 0 | 0 | |
| 44 | 75 | 0 | 0 | 0 | 0 | 0 | 0 | 0 | 0 | 0 | 0 | 0 | 0 | 0 | 0 | 0 | 0 | 0 | 0 | 0 | 0 | 0 | |
| 45 | 80 | 0 | 0 | 0 | 0 | 0 | 0 | 0 | 0 | 0 | 0 | 0 | 0 | 0 | 0 | 0 | 0 | 0 | 0 | 0 | 0 | 0 | |
| 46 | 85 | 0 | 0 | 0 | 0 | 0 | 0 | 0 | 0 | 0 | 0 | 0 | 0 | 0 | 0 | 0 | 0 | 0 | 0 | 0 | 0 | 0 | |
| 47 | | | | | | | | | | | | | | | | | | | | | | | |

Figure 4.3: Modified rational method runoff hydrograph for example drainage area. Applied storm duration is equal to the watershed characteristic time.

The kernel function $f(t)$ appears as columns starting at row 9 in the table. Each column is shifted in time by one time increment ($\Delta\tau = 5$ minutes), and appear to the right of the indicated kernel function column. The sum of each these rows appears in Row 27; this sum is the normalization constant.

The response to each rainfall input is the product of the kernel function, the normalization constant

(Row 27) and the excess rainfall intensity (Row 7). These responses appear as columns beneath the kernel function array. The total runoff for the particular time is the sum across rows of the response function, multiplied by the watershed area.

Figure 4.4 is a plot of the 10-minute rainfall hyetograph (solid trace) applied to the example watershed and the corresponding direct runoff hydrograph (dashed trace). The peak discharge occurs at T^* time units after the start of the rainfall (in this case 10 minutes). The peak discharge value is $Q_p = 57.1$ cfs; exactly the same value as in the unified rational method — an anticipated result.

The total volume of runoff (area under the dashed trace) is 34,272 cfs. The total volume of rainfall into the watershed (area under the solid trace) is 101,640 ft^3 . In this example, and for modified rational methods in general, the runoff coefficient is a volumetric concept; that is the runoff to rainfall ratio is the runoff coefficient ($\frac{34,272}{101,640} = 0.337 \approx 0.34$)

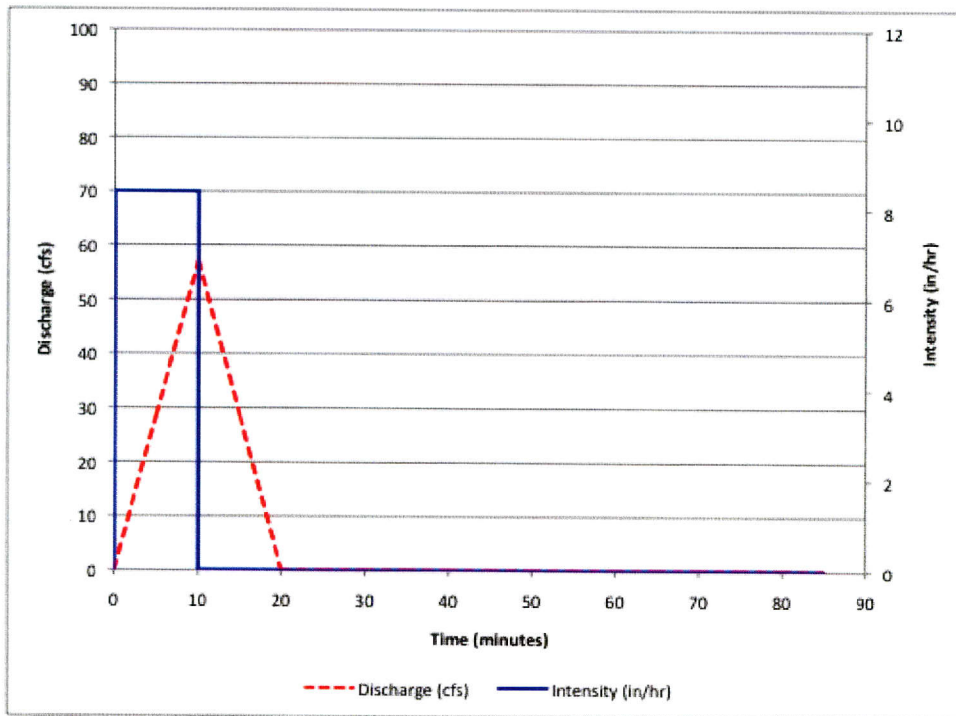

Figure 4.4: Modified rational method runoff hydrograph for example drainage area. Applied storm duration is equal to the watershed characteristic time $T^* = 10$ minutes. The peak discharge is $Q_p = 57.1$ cfs; the same as the URAT peak estimate.

The modified rational method is not limited to storms that equal the watershed characteristic time. It can be applied for storms that are longer than the characteristic time (or shorter). As an illustration, the assume that a 60-minute, 25-year rainfall occurs over the area of interest. The input rainfall rate is 3.4 inches/hour as per Asquith and Roussel (2004). This rate is smaller than the 10-minute rate because of the longer duration of the storm. The resulting computations are presented in Figure 4.5 and the corresponding hydrograph is shown in Figure 4.6.

| | A | B | C | D | E | F | G | H | I | J | K | L | M | N | O | P | Q | R | S | T | U | V |
|----|----------------------------|---|-----|-----|-----|-----|-----|-----|-----|-----|-----|-----|-----|-----|-----|-----|-----|-----|-----|-----|-----|-----|
| 1 | 0-6070 MRM Example - 2 | | | | | | | | | | | | | | | | | | | | | |
| 2 | Area: 20 acres | | | | | | | | | | | | | | | | | | | | | |
| 3 | Tc: 10 minutes | | | | | | | | | | | | | | | | | | | | | |
| 4 | C: 0.34 runoff-coefficient | | | | | | | | | | | | | | | | | | | | | |
| 5 | Time (minutes) | 0 | 5 | 10 | 15 | 20 | 25 | 30 | 35 | 40 | 45 | 50 | 55 | 60 | 65 | 70 | 75 | 80 | 85 | | | |
| 6 | Intensity (in/hr) | 3.4 | 3.4 | 3.4 | 3.4 | 3.4 | 3.4 | 3.4 | 3.4 | 3.4 | 3.4 | 3.4 | 3.4 | 0.0 | 0.0 | 0.0 | 0.0 | 0.0 | 0.0 | 0.0 | 0.0 | 0.0 |
| 7 | Excess (in/hr) | 1.2 | 1.2 | 1.2 | 1.2 | 1.2 | 1.2 | 1.2 | 1.2 | 1.2 | 1.2 | 1.2 | 1.2 | 0.0 | 0.0 | 0.0 | 0.0 | 0.0 | 0.0 | 0.0 | 0.0 | 0.0 |
| 8 | Time | Kernel Function, shifted for each time | | | | | | | | | | | | | | | | | | | | |
| 9 | 0 | 0 | 0 | 0 | 0 | 0 | 0 | 0 | 0 | 0 | 0 | 0 | 0 | 0 | 0 | 0 | 0 | 0 | 0 | 0 | 0 | 0 |
| 10 | 5 | 0.1 | 0 | 0 | 0 | 0 | 0 | 0 | 0 | 0 | 0 | 0 | 0 | 0 | 0 | 0 | 0 | 0 | 0 | 0 | 0 | 0 |
| 11 | 10 | 0.1 | 0.1 | 0 | 0 | 0 | 0 | 0 | 0 | 0 | 0 | 0 | 0 | 0 | 0 | 0 | 0 | 0 | 0 | 0 | 0 | 0 |
| 12 | 15 | 0 | 0.1 | 0.1 | 0 | 0 | 0 | 0 | 0 | 0 | 0 | 0 | 0 | 0 | 0 | 0 | 0 | 0 | 0 | 0 | 0 | 0 |
| 13 | 20 | 0 | 0 | 0.1 | 0.1 | 0 | 0 | 0 | 0 | 0 | 0 | 0 | 0 | 0 | 0 | 0 | 0 | 0 | 0 | 0 | 0 | 0 |
| 14 | 25 | 0 | 0 | 0 | 0.1 | 0.1 | 0 | 0 | 0 | 0 | 0 | 0 | 0 | 0 | 0 | 0 | 0 | 0 | 0 | 0 | 0 | 0 |
| 15 | 30 | 0 | 0 | 0 | 0 | 0.1 | 0.1 | 0 | 0 | 0 | 0 | 0 | 0 | 0 | 0 | 0 | 0 | 0 | 0 | 0 | 0 | 0 |
| 16 | 35 | 0 | 0 | 0 | 0 | 0 | 0.1 | 0.1 | 0 | 0 | 0 | 0 | 0 | 0 | 0 | 0 | 0 | 0 | 0 | 0 | 0 | 0 |
| 17 | 40 | 0 | 0 | 0 | 0 | 0 | 0 | 0.1 | 0.1 | 0 | 0 | 0 | 0 | 0 | 0 | 0 | 0 | 0 | 0 | 0 | 0 | 0 |
| 18 | 45 | 0 | 0 | 0 | 0 | 0 | 0 | 0 | 0.1 | 0.1 | 0 | 0 | 0 | 0 | 0 | 0 | 0 | 0 | 0 | 0 | 0 | 0 |
| 19 | 50 | 0 | 0 | 0 | 0 | 0 | 0 | 0 | 0 | 0.1 | 0.1 | 0 | 0 | 0 | 0 | 0 | 0 | 0 | 0 | 0 | 0 | 0 |
| 20 | 55 | 0 | 0 | 0 | 0 | 0 | 0 | 0 | 0 | 0 | 0.1 | 0.1 | 0 | 0 | 0 | 0 | 0 | 0 | 0 | 0 | 0 | 0 |
| 21 | 60 | 0 | 0 | 0 | 0 | 0 | 0 | 0 | 0 | 0 | 0 | 0.1 | 0.1 | 0 | 0 | 0 | 0 | 0 | 0 | 0 | 0 | 0 |
| 22 | 65 | 0 | 0 | 0 | 0 | 0 | 0 | 0 | 0 | 0 | 0 | 0 | 0.1 | 0.1 | 0 | 0 | 0 | 0 | 0 | 0 | 0 | 0 |
| 23 | 70 | 0 | 0 | 0 | 0 | 0 | 0 | 0 | 0 | 0 | 0 | 0 | 0 | 0.1 | 0.1 | 0 | 0 | 0 | 0 | 0 | 0 | 0 |
| 24 | 75 | 0 | 0 | 0 | 0 | 0 | 0 | 0 | 0 | 0 | 0 | 0 | 0 | 0 | 0.1 | 0.1 | 0 | 0 | 0 | 0 | 0 | 0 |
| 25 | 80 | 0 | 0 | 0 | 0 | 0 | 0 | 0 | 0 | 0 | 0 | 0 | 0 | 0 | 0 | 0.1 | 0.1 | 0 | 0 | 0 | 0 | 0 |
| 26 | 85 | 0 | 0 | 0 | 0 | 0 | 0 | 0 | 0 | 0 | 0 | 0 | 0 | 0 | 0 | 0 | 0.1 | 0.1 | 0 | 0 | 0 | 0 |
| 27 | SUM | 0.2 | 0.2 | 0.2 | 0.2 | 0.2 | 0.2 | 0.2 | 0.2 | 0.2 | 0.2 | 0.2 | 0.2 | 0.2 | 0.2 | 0.2 | 0.2 | 0.2 | 0.1 | 0.1 | 0 | 0 |
| 28 | Time | Response Function; Each column is product of Excess and Kernel divided by the Normalization Constant. | | | | | | | | | | | | | | | | | | | | |
| 29 | 0 | 0 | 0 | 0 | 0 | 0 | 0 | 0 | 0 | 0 | 0 | 0 | 0 | 0 | 0 | 0 | 0 | 0 | 0 | 0 | 0 | 0 |
| 30 | 5 | 0.6 | 0 | 0 | 0 | 0 | 0 | 0 | 0 | 0 | 0 | 0 | 0 | 0 | 0 | 0 | 0 | 0 | 0 | 0 | 0 | 0 |
| 31 | 10 | 0.6 | 0.6 | 0 | 0 | 0 | 0 | 0 | 0 | 0 | 0 | 0 | 0 | 0 | 0 | 0 | 0 | 0 | 0 | 0 | 0 | 0 |
| 32 | 15 | 0 | 0.6 | 0.6 | 0 | 0 | 0 | 0 | 0 | 0 | 0 | 0 | 0 | 0 | 0 | 0 | 0 | 0 | 0 | 0 | 0 | 0 |
| 33 | 20 | 0 | 0 | 0.6 | 0.6 | 0 | 0 | 0 | 0 | 0 | 0 | 0 | 0 | 0 | 0 | 0 | 0 | 0 | 0 | 0 | 0 | 0 |
| 34 | 25 | 0 | 0 | 0 | 0.6 | 0.6 | 0 | 0 | 0 | 0 | 0 | 0 | 0 | 0 | 0 | 0 | 0 | 0 | 0 | 0 | 0 | 0 |
| 35 | 30 | 0 | 0 | 0 | 0 | 0.6 | 0.6 | 0 | 0 | 0 | 0 | 0 | 0 | 0 | 0 | 0 | 0 | 0 | 0 | 0 | 0 | 0 |
| 36 | 35 | 0 | 0 | 0 | 0 | 0 | 0.6 | 0.6 | 0 | 0 | 0 | 0 | 0 | 0 | 0 | 0 | 0 | 0 | 0 | 0 | 0 | 0 |
| 37 | 40 | 0 | 0 | 0 | 0 | 0 | 0 | 0.6 | 0.6 | 0 | 0 | 0 | 0 | 0 | 0 | 0 | 0 | 0 | 0 | 0 | 0 | 0 |
| 38 | 45 | 0 | 0 | 0 | 0 | 0 | 0 | 0 | 0.6 | 0.6 | 0 | 0 | 0 | 0 | 0 | 0 | 0 | 0 | 0 | 0 | 0 | 0 |
| 39 | 50 | 0 | 0 | 0 | 0 | 0 | 0 | 0 | 0 | 0.6 | 0.6 | 0 | 0 | 0 | 0 | 0 | 0 | 0 | 0 | 0 | 0 | 0 |
| 40 | 55 | 0 | 0 | 0 | 0 | 0 | 0 | 0 | 0 | 0 | 0.6 | 0.6 | 0 | 0 | 0 | 0 | 0 | 0 | 0 | 0 | 0 | 0 |
| 41 | 60 | 0 | 0 | 0 | 0 | 0 | 0 | 0 | 0 | 0 | 0 | 0.6 | 0.6 | 0 | 0 | 0 | 0 | 0 | 0 | 0 | 0 | 0 |
| 42 | 65 | 0 | 0 | 0 | 0 | 0 | 0 | 0 | 0 | 0 | 0 | 0 | 0.6 | 0.6 | 0 | 0 | 0 | 0 | 0 | 0 | 0 | 0 |
| 43 | 70 | 0 | 0 | 0 | 0 | 0 | 0 | 0 | 0 | 0 | 0 | 0 | 0 | 0.6 | 0.6 | 0 | 0 | 0 | 0 | 0 | 0 | 0 |
| 44 | 75 | 0 | 0 | 0 | 0 | 0 | 0 | 0 | 0 | 0 | 0 | 0 | 0 | 0 | 0.6 | 0.6 | 0 | 0 | 0 | 0 | 0 | 0 |
| 45 | 80 | 0 | 0 | 0 | 0 | 0 | 0 | 0 | 0 | 0 | 0 | 0 | 0 | 0 | 0 | 0.6 | 0.6 | 0 | 0 | 0 | 0 | 0 |
| 46 | 85 | 0 | 0 | 0 | 0 | 0 | 0 | 0 | 0 | 0 | 0 | 0 | 0 | 0 | 0 | 0 | 0.6 | 0.6 | 0 | 0 | 0 | 0 |
| 47 | | | | | | | | | | | | | | | | | | | | | | |

Figure 4.5: Modified rational method runoff hydrograph for example drainage area. Applied storm duration $T_D = 60$ minutes is six times the watershed characteristic time of $T^* = 10$ minutes.

Without any other changes in the underlying parameters the peak discharge for this longer duration storm (but lower intensity as per Asquith and Roussel (2004)) is $Q_p = 23.1$ cfs. This peak is sustained for 50 minutes time. The total volume of runoff is $83,232 \text{ ft}^3$, the total input rainfall is $246,840 \text{ ft}^3$, the runoff ratio is $\frac{83,232}{246,840} = 0.337 \approx 0.34$. As in the prior example the runoff coefficient is again a volumetric concept in the modified rational method hydrograph generation procedure.

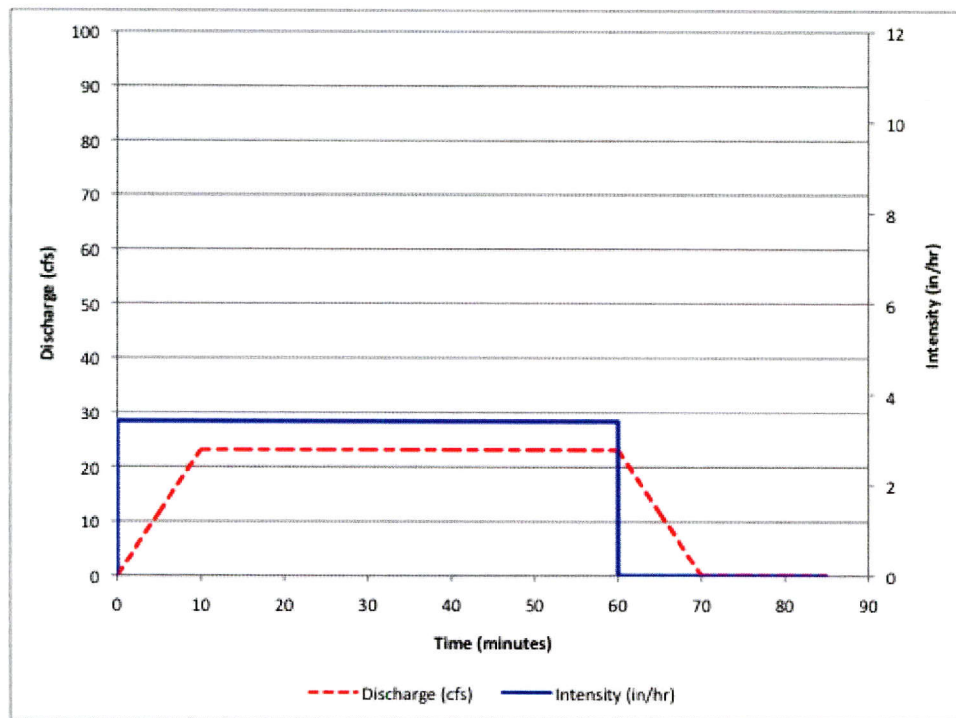

Figure 4.6: Modified rational method runoff hydrograph for example drainage area. Applied storm duration $T_D = 60$ minutes is six times the watershed characteristic time of $T^* = 10$ minutes. The peak discharge is $Q_p = 23.1$ cfs and is sustained for 50 minutes.

These two hyetograph-hydrograph examples both share common probability — that is they all represent runoff from a 25-year storm. The different storm durations are adjusted according to the depth-duration frequency of rainfall to produce the appropriate intensity; the 10-minute storm has a high instantaneous intensity (8.4 inches per hour), the 60-minute storm a lesser instantaneous intensity (3.4 inches per hour).

4.2.1. Non-Uniform Rainfall

Another value of the modified rational method is in exploring cases beyond the application of the rational method. The first useful application is to apply the modified rational method to non-uniform rainfall time series. As in unit hydrograph analysis, the responses to different rainfall inputs are convolved to produce a runoff hydrograph. The modified method is simply a subset of this concept and arguably does not constitute an effort savings, however, parameterizing might be considerably simpler.

The same example watershed with a non-uniform storm applied is illustrated in Figure 4.7. The only computational change is in the applied hyetograph, the remaining computational elements are unchanged. The example is contrived, but the meaning is clear; a complicated input hyetograph

can be handled by the method. In this particular illustration the peak discharge is $Q_p = 71.4$ cfs caused by the 5-minute long, 18 inch per hour rainfall pulse.

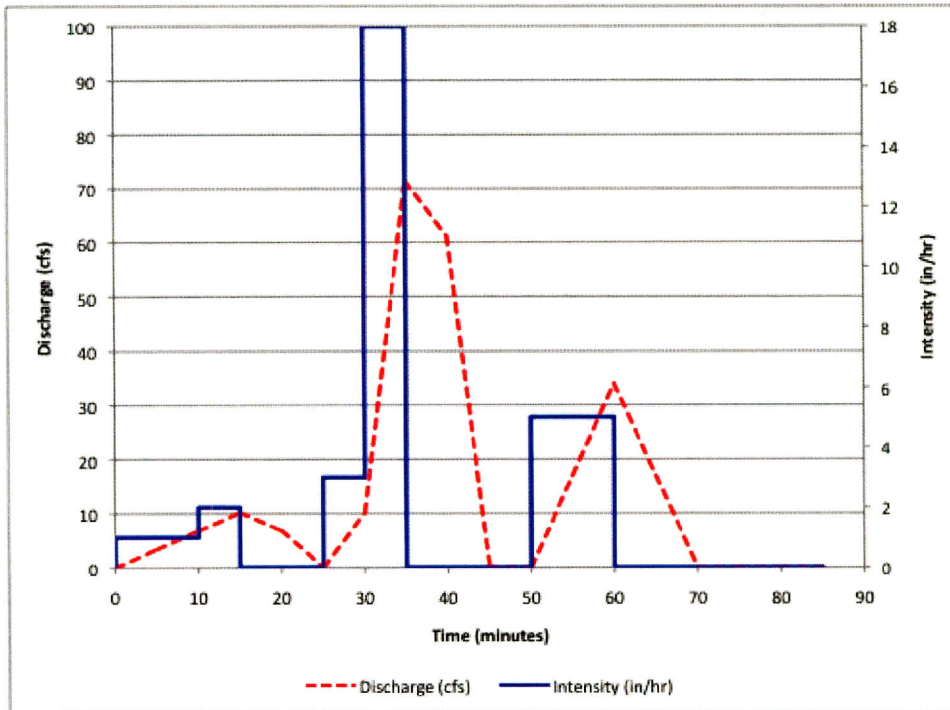

Figure 4.7: Modified rational method runoff hydrograph for example drainage area. Applied storm is non-uniform. $Q_p = 71.4$ cfs at 35 minutes.

4.2.2. Characteristic Time Assessment

The other powerful component of the modified rational method is assessing engineering impacts on the response time. In our example, the characteristic time of the watershed is 10 minutes by either the conventional or unified rational method. Suppose however, we can implement stormwater control practices that increase this time, say 50-percent. That is, we start with the watershed as-is, and then through certain practices extend the response time a bit.

This idea is illustrated using the last non-uniform storm. The only change is we assume is that the response time is increased from 10 to 15 minutes. All other components remain the same.

The example illustrates the effect that engineering practices that lengthen time can have on a design. In this example the peak discharge estimate is reduced 30 percent by practices that extend the characteristic time by 5 minutes. The requirements to add 5 minutes to the time of concentration may be non-trivial; but for a small system swales or berms that force longer flow paths might achieve such a result.

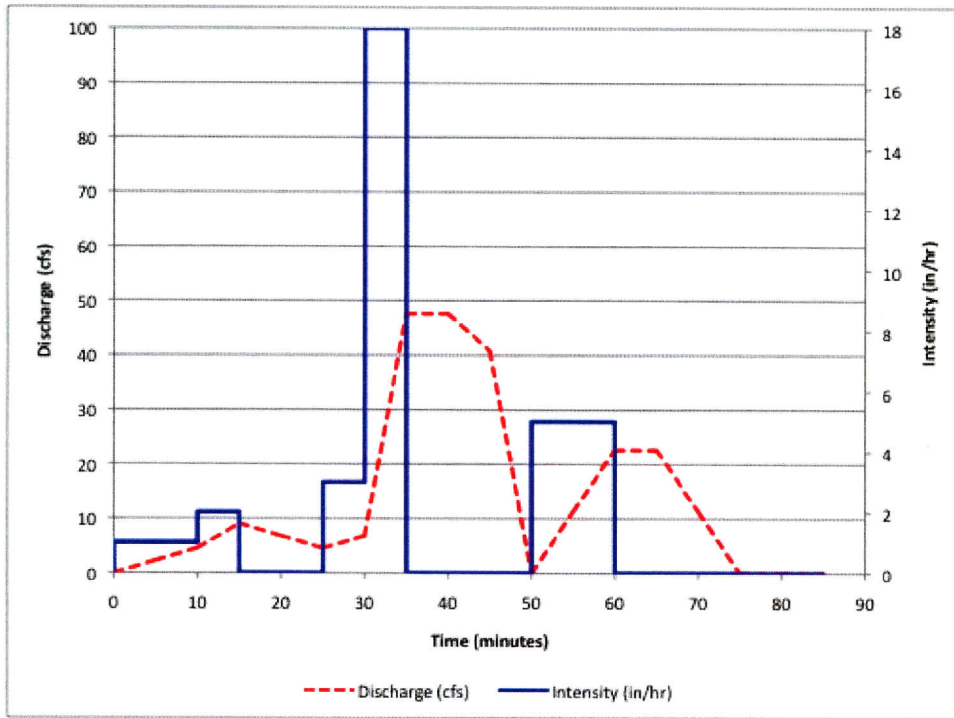

Figure 4.8: Modified rational method runoff hydrograph for example drainage area. Applied storm is non-uniform. Watershed characteristic time increased to $T^* = 15$ minutes. $Q_p = 47.6$ cfs at 35 minutes.

4.3. Regression Equation Adjustments

The Unified Rational Method (URAT) is thoroughly described in Section 3. An illustrative example of direct application of URAT was presented above, comparing both conventional analysis as well as the URAT method for Texas. The example was extended to illustrate URAT as a way to parameterize the modified rational method for hydrograph generation, and several different hydrographs were developed.

A flowchart depicting the application of URAT is shown in Figure 4.9. The figure shows an entry point of watershed characteristics. This section extends the presentation by Asquith in Section 3, and in the illustrative example by recognizing that two semi-distinct estimates of peak-streamflow frequency can be acquired from URAT.

First, the URAT method through conventional computations of the rational equation provide estimates of peak-streamflow for a selected frequency — this approach to use of the tool is already presented in the examples above. Figure 4.10 depicts the analysis pathway of this forward (and most anticipated) model use.

The analyst enters the tool with watershed properties of area (in acres), slope, location (in Texas), and an estimate of functionally impervious fraction. The analyst then uses the tables provided in

Figure 4.9: Flowchart of application of Unified Rational Method for Texas.

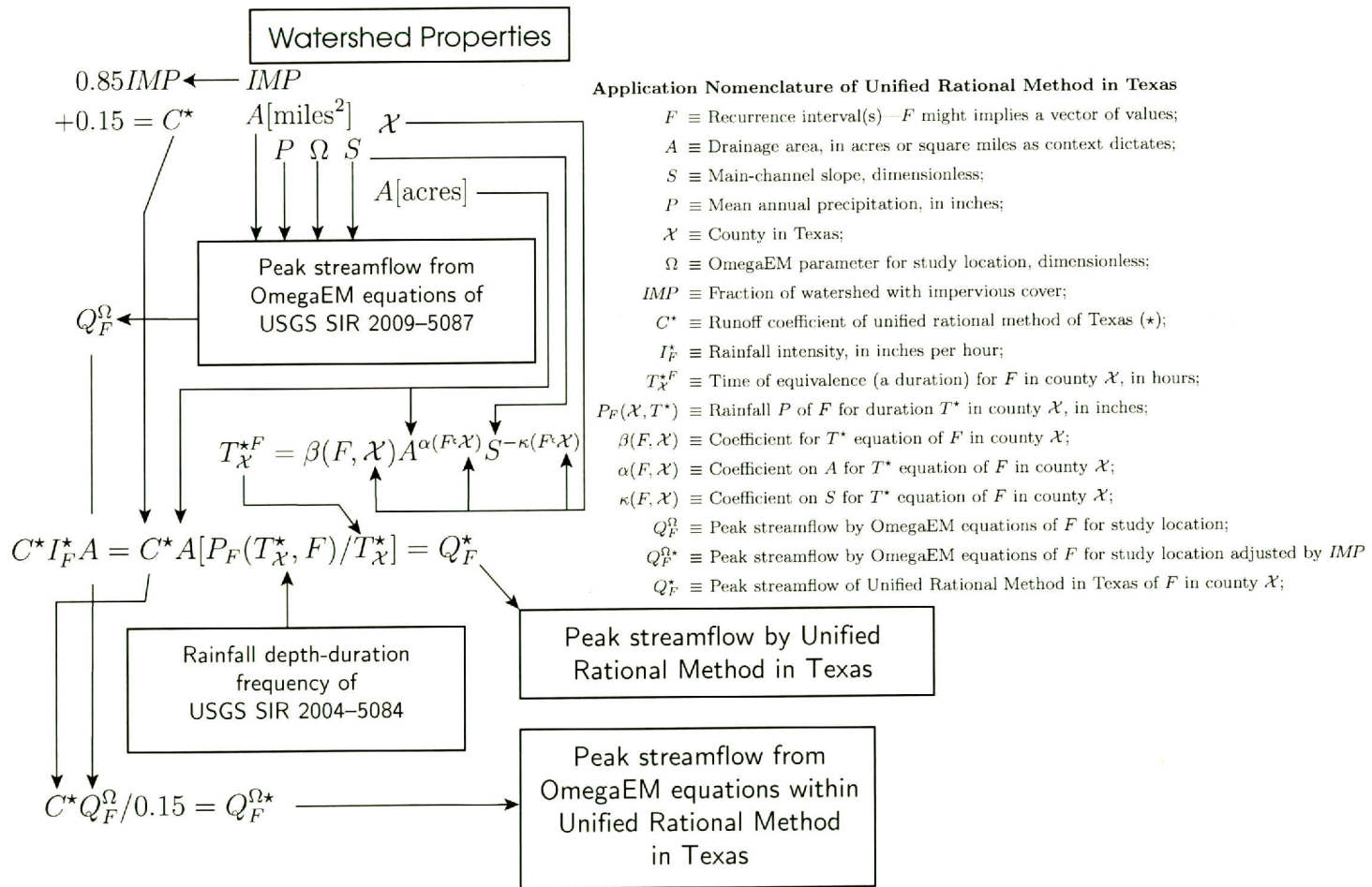

this report to estimate T^* . With this estimate, the analyst then determines a depth for a specified frequency from the DDF Atlas (Asquith and Roussel (2004)) or similar tool, applies T^* to determine an intensity and the result is a peak discharge.

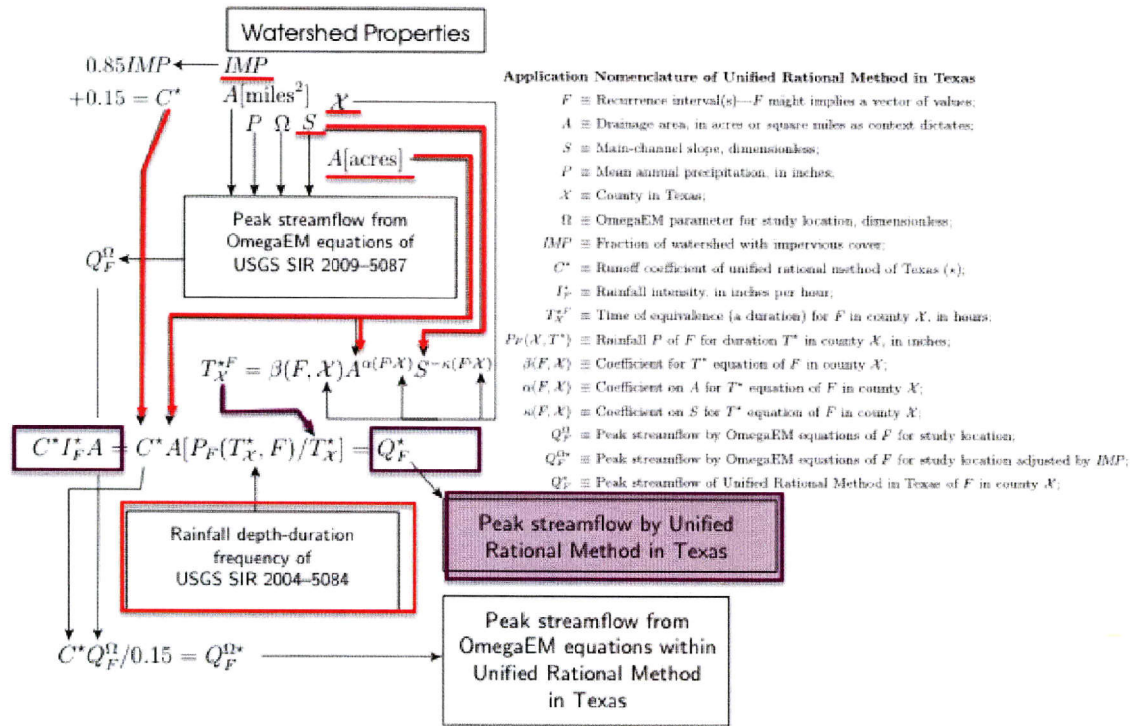

Figure 4.10: Unified Rational Method – Forward Modeling Pathway. Result is a peak discharge estimate for a location in Texas for a specified frequency.

This forward modeling is the most anticipated use of URAT, with extension into the modified method where hydrographs are needed.

Second, the peak-streamflow from the OmegaEM equations of Asquith and Roussel (2009) could be adjusted by the runoff coefficient of URAT as shown in the diagram — this component has value in planning for growth using impervious cover as a surrogate for development. Figure 4.11 illustrates the analysis pathway for this application of the research.

The analyst enters the tool with watershed properties of area (in square miles), main channel slope, mean annual precipitation, and OmegaEM as described in Asquith and Roussel (2009). The result is a peak discharge for a specified frequency. Next, the value of C^* is computed from the fraction of impervious cover to adjust the peak discharge for increased infrastructure. The premise here is that the OmegaEM estimates are reflective of comparatively unimproved conditions, and the adjustment is to help anticipate effects of infrastructure addition.

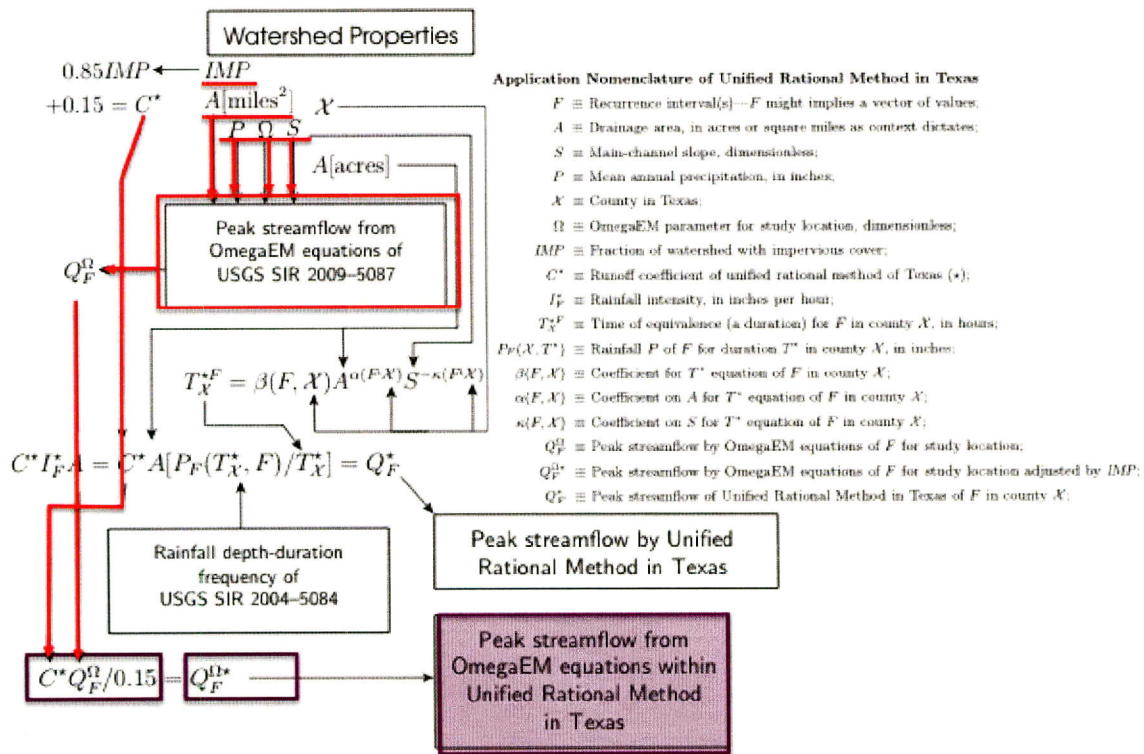

Figure 4.11: Unified Rational Method – Regression Equation Adjustment. Result is an adjusted peak discharge to reflect potential infrastructure additions in Texas for a specified frequency.

5. SUMMARY AND CONCLUSIONS

This section of the report summarizes the research activities and contributions. The conclusions contain specific findings as well as suggestions for application of the rational and modified rational methods. Suggestions for future work are listed because the process of research often uncovers additional questions that cannot be addressed within the given time and budgetary limits. Possible implementation of the research to efficiently use the tools presented are also presented.

5.1. Summary

The researchers examined the rational and modified rational method for drainage infrastructure design to control storm water from small watersheds.

The researchers developed the Unified Rational Method for Texas (URAT) as a viable alternative to the conventional rational method. The principal features of the URAT are that the runoff coefficient specification is simplified, and the entire “probability” component is assigned to the computation of rainfall intensity. Thus, probability adjustments to runoff coefficients are eliminated. Furthermore, the URAT analysis explicitly associates runoff probabilities with rainfall probabilities so that the implicit assumption that a T -year rainfall produces a T -year runoff event is rendered irrelevant.

A set of tables, by county, for estimating three components of an adjusted time equation replace the conventional approach of estimating time of concentration by various applications of time and distance computations — yet produces results consistent with such procedures.

Several application examples are presented to illustrate the URAT method, extend the method to a modified rational hydrograph method, and to adjust regional regression equations when desired. The effort required to implement the URAT as compared to the conventional is about the same, perhaps reduced slightly because less effort in the specification of the runoff coefficient is required.

A set of appendices that documents various lines of investigation that were attempted during the research are included to provide interested readers insight into what the report authors were thinking at different times during the research. These appendices are somewhat stand-alone, and represent both successful paths and unsuccessful paths. The appendices are likely to be of value to future researchers and designers as background materials, but are not vital to the URAT method per-se.

5.2. Conclusions

The original project objectives were to:

1. Evaluate the appropriateness of using both rational and modified rational methods for small watershed design
2. Evaluate the tabulated values of the runoff coefficient, and
3. Construct guidelines for TxDOT analysts for selection of appropriate parameter values for Texas watershed conditions.

These objectives are explicitly satisfied by the following conclusions in sequel to the remainder of this report:

1. In their basic structural mathematical forms, the rational and modified rational methods *remain appropriate models of small watershed Texas hydrology* when used with careful consideration of uncertainties. The most important source of uncertainty is the specification of characteristic time (a watershed property). The URAT methodology is a defensible attempt to mitigate this uncertainty.
2. The drainage area limit for application of the rational method appears unidentifiable from analysis of observed rainfall and runoff. Further, the clever equivalence of time used to develop the Unified Rational Method, provides no additional insight in the upper drainage area limit. The authors suspect that for simple watersheds the upper limit could be extended from the community accepted value of 200 acres to 640 acres. The critical assumption for applicability of the rational method is whether the steady-state assumption can hold for multi-hundred acre watersheds.
3. The granularity or resolution suggested in tabulated ensembles of the runoff coefficient from the literature is difficult to justify. The literature coefficients are conceptually inverted runoff coefficients, although there are some volumetric coefficients in the runoff coefficient database.
4. The authors suggest that it unnecessary to break a watershed into subbasins for purposes of computing a runoff coefficient, as there is not much precision in the coefficient in light of the previous comment, and composite runoff coefficient values for a watershed are an obfuscation. A caveat is that C^* in its strictest sense is a composite coefficient of two types of runoff contribution areas, the authors suggest that should composite values be used two or three runoff contribution areas should be more than sufficient.
5. The modified rational method can use tabulated coefficients and generate runoff hydrographs. Conceptually, the modified rational method is a unit hydrograph method, and hence the runoff coefficients are conceptually volumetric coefficients. Analysis of rainfall-runoff data in Texas indicated that when the modified rational method is employed, the runoff coefficients derived from the literature are on average too large by a factor of about 2.
6. An alternative to the conventional rational method was developed; the Unified Rational Method. The method eliminates probability adjusted runoff coefficients (and land-use based

coefficients entirely). The method collapses all probability estimation into the specification of time and consequently intensity.

7. The Unified Rational Method provides the first tuned version of the rational method for the intensity-duration frequency and flood-flow frequency equations in Texas.
8. The runoff coefficient of the Unified Rational Method is comparable to other incarnations of the rational method. However, how to adjust this coefficient for watershed slope and intensity of rainfall (recurrence interval) is unknown, and instead these considerations are included by having watershed time dependent on slope and recurrence interval.
9. Example applications illustrate how to use the unified rational method for design application.
10. Where possible, additional methods for estimation of peak discharge be consulted as part of standard design practice — this theme is the point of the regression equation adjustments.

The researchers suggest that the Unified Rational Method is a substitute for the conventional rational method. URAT substitutes considerable land-use specification subjectivity, slope influence, and probability adjustments to runoff coefficients by a simple area-weighted coefficient based on functional impervious cover and pervious cover. URAT incorporates the effect of slope and probability adjustments in the specification of the watershed time of equivalence — a characteristic time that makes rational peak discharges and regression equation peak discharges equal at some specified recurrence interval — a tuning that eliminates the implicit probability equivalence assumption in the conventional rational method.

The researchers suggest that URAT minimum characteristic time be limited to 10 minutes for essentially the same reasons as in conventional rational method — to prevent unrealistically large intensities.

The modified rational method is unchanged except for the use of the URAT approach to parameterize the hydrograph generation model.

5.3. Further Work

Suggestions for further work are divided into additional research, and possible implementation activities.

5.3.1. Additional Research

The concept of probability equivalence was solved comparatively late in the research. It was a very challenging problem indeed to scientifically evaluate the effect of recurrence interval in the equality between the left and right hand sides of the rational equation. The researchers are comfortable with the material presented in this report, but some of the ideas are somewhat novel and bear evaluation as time permits.

The runoff coefficient based on impervious cover is not unique to this research and other instances of a similar structure (but different numerical values) exist. For example (Schueler, 1987) is identical in structure, but with different values for the asymptotic ($IMP = 0$ and $IMP = 1$) conditions of the watershed. The best structure for current and near-future Texas conditions would be a desirable follow-up research project.

5.3.2. Implementation of Results

The implementation of URAT is contained in this report. There would be some value in coding the county-by-county tables into an environment like the EBDLKUP.xls spreadsheet supplied in the Hydrology appendix of the 2009 TxDOT Hydraulic Design Manual, but the method as presented is available for immediate application. Likewise, there may be some value into coding a modified rational method hydrograph generator into such a computational environment as an added convenience.

BIBLIOGRAPHY

- Akan, A. O. (2002). Modified rational method for sizing infiltration structures. *Canadian Journal of Civil Engineering* 29, 539–542.
- American Society of Civil Engineers (1996). *Hydrology Handbook* (2nd ed.). American Society of Civil Engineers.
- Aron, G. and D. F. Kibler (1990). Pond sizing for rational formula hydrographs. *Water resources bulletin* 26(2), 255–258.
- Aron, G. and E. White (1982). Fitting a gamma distribution over a synthetic unit hydrograph. *Water Resources Bulletin* 18(1), 95–98.
- ASCE (1992). *Design and Construction of Urban Stormwater Management Systems*. New York, NY: American Society of Civil Engineers.
- Asquith, W. H. and M. C. Roussel (2004). Atlas of depth-duration frequency of precipitation annual maxima for Texas. Scientific Investigations Report 2004–5041, U.S. Geological Survey, Austin, Texas.
- Asquith, W. H. and M. C. Roussel (2007). An initial abstraction, constant-loss model for unit hydrograph modeling for applicable watersheds in Texas. Scientific Investigations Report 2007–5243, U.S. Geological Survey, Austin, Texas 78754.
- Asquith, W. H. and M. C. Roussel (2009). Regression equations for estimation of annual peak-streamflow frequency for undeveloped watersheds in Texas using an L-moment-based, PRESS-minimized, residual-adjusted approach. Scientific Investigations Report 2009–5087, U.S. Geological Survey, Austin, Texas 78754.
- Asquith, W. H. and R. M. Slade (1997). Regional equations for estimation of peak-streamflow frequency for natural basins in Texas. Water-Resources Investigation Report 96–4307, U.S. Geological Survey, Austin, Texas. (In PDF).
- Asquith, W. H., D. B. Thompson, T. G. Cleveland, and X. Fang (2004). Synthesis of rainfall and runoff data used for Texas Department of Transportation research projects 0–4193 and 0–4194. Open-File Report 2004–1035 (TxDOT Reports 0–4193–2 and 0–4194–2), U.S. Geological Survey, Austin, Texas.
- Bedient, P. and W. Huber (2002). *Hydrology and floodplain analysis*. Upper Saddle River, NJ 07458: Prentice Hall.

- Bengtsson, L. and J. Niemczynowicz (1998). Using the rational method for design in complex urban basins. *Nordic Hydrology* 29(2), 73–90.
- Calder, I., R. Hall, R. Harding, and et al. (1984). The use of a wet-surface weighing lysimeter system in rainfall interception studies of heather. *Journal of Climate and Applied Meteorology* Vol. 23(No. 3), 461–473.
- Caspany, H. (1990). An ecohydrological framework for water yield changes of forested catchments due to forest decline and soil acidification. *WATER RESOURCES RESEARCH* Vol. 26(No. 6), 1121–1131.
- Chen, C. and T. Wong (1989). Development of the rational method for flood design for small rural basins in Australia. In *Proceedings of the International Conference for Centennial of Mannings Formula and Kuichling's Rational Formula*, pp. 61–70. Department of Civil Engineering, University of Virginia, Charlottesville, VA.
- Chien, J. and K. Saigal (1974). Urban runoff by linearized subhydrograph method. *Journal of the Hydraulics Division* 100(HY8), 1141–1157.
- Chui, P. C., T. S. W. Wong, and S. H. Poon (1994). Development of the rational method for flood design for small rural basins in Australia. In *Proceedings of the International Conference for Centennial of Manning's Formula and Kuichling's Rational Formula*, Charlottesville, Virginia, pp. 61–70. Department of Civil Engineering, University of Virginia.
- Clark, C. (1943). Storage and the unit hydrograph. *Transactions: American Society of Civil Engineers* 69, 1419–1488.
- Dhakal, N., X. Fang, T. G. Cleveland, D. B. Thompson, W. H. Asquith, and L. Marzen (2010). Estimation of runoff coefficients for Texas watersheds using land-use and rainfall-runoff data. In *Challenges of Change: Proceedings of the World Environmental and Water Resources Congress 2010*.
- Dingman, S. L. (2002). *Physical hydrology* (2nd edition ed.). Upper Saddle River, NJ 07458: Prentice-Hall.
- Dooge, J. (1957). The rational method for estimating flood peaks. *Engineering, London* (184), 311–374.
- Fang, X. and D. Su (2006). An integrated one-dimensional and two-dimensional urban stormwater flood simulation model. *Journal of the American water resources association* 42(3), 713–724.
- Fang, X., D. B. Thompson, T. G. Cleveland, and P. Pradhan (2007). Variations in time of concentration estimates using the NRCS velocity method. *Journal of Irrigation and Drainage Engineering* 133(4), 314–322.
- FHWA (1980). *Underground Disposal of Stormwater Runoff*. Report No. FHWA-TS-80-218. Washington, D.C.: Federal Highway Administration.

- FHWA (1983). *Urban Highway Storm Drainage Model*. Report No. FHWA/RD-83/043. Washington, D.C.: Federal Highway Administration.
- Guo, J. C. (2000). Storm hydrographs from small urban catchments. *Water international* 25(3), 481–487.
- Guo, J. C. (2001). Rational hydrograph method for small urban watersheds. *Journal of hydrologic engineering* 6(4), 352–356.
- Haan, C. T., B. J. Barfield, and J. C. Hayes (1994). *Design hydrology and sedimentology for small catchments*. Academic Press.
- Hayes, D. C. and R. L. Young (2005). Comparison of peak discharge and runoff characteristic estimates from the rational method to field observations for small basins in Central Virginia. Scientific Investigations Report 2005–5254, U.S. Geological Survey, Reston, Virginia.
- Hershfield, D. M. (1961). Rainfall frequency atlas of the United States for durations of 30 minutes to 24 hours and return periods from 1 to 100 years. Technical Paper 40, U.S. Department of Commerce, Weather Bureau, Washington, D.C.
- Hydrologic Engineering Center (1998). *HEC-1 Flood Hydrograph Package, User's Manual*. 609 Second Street, Davis, CA 95616-4687: U.S. Army Corps of Engineers.
- Hydrology, I. (1976). Water balance of the headwaters oin catchemnts wye and severen. 1970-1975. Report No. 33, Institute of Hydrology, UK.
- Kerby, W. (1959). Time of concentration for overland flow. *Civil Engineering* 29(3), 60.
- Kirby, C., M. Newson, and K. Gillman (1991). Plynlimon research – the first two decades. Report No. 109, Institute of Hydrology, UK.
- Kirpich, Z. (1940). Time of concentration of small agricultural watersheds. *Civil Engineering* 10(6), 362. The original source for the Kirpich equation. (In PDF).
- Kuichling, E. (1889). The relation between the rainfall and the discharge of sewers in populous districts. *Transactions, American Society of Civil Engineers* 20, 1–56.
- Law, F. (1956). The effect of afforestation upon the yield of water catchment areas. Technical report, British Association for Advancement of Science, Sheffield, England.
- Leopold, L. B. and T. Dunne (1978). *Water in Environmental Planning*. New York, NY: W.H. Freeman and Company.
- Lloyd, C., J. Gash, Shuttleworth, and others. (1988). The measurement and modeling of rainfall interception by amazonian rain-forest. *Agricultural and Forest Meterology Vol. 43*(No. 3-4), 277–294.
- Lloyd-Davies, D. E. (1906). The elimination of storm-water from sewerage systems. *Minutes of proceedings, Institution of Civil Engineers, Great Britain* 164, 41–67.

- Madramootoo, C. (1989). Some observations on the rational method for peak flow prediction on flat rural watersheds in Quebec. *Canadian Water Resources* 15(1), 5–11.
- Maidment, D. R. (Ed.) (1993). *Handbook of hydrology*. New York, NY: McGraw-Hill.
- McCuen, R. H. (1998). *Hydrologic analysis and design*. (Second ed.). Upper Saddle River, NJ 07458: Prentice-Hall, Inc.
- McDonnell, J. (1990). A rationale for old water discharge through macropores in a steep, humid catchment. *Water Resources Research* Vol. 26(No. 11), 2821–2832.
- McPherson, M. B. (1969). *Some notes in the rational method of storm drain design.*, Chapter Technical Memorandum No. 6. New York, NY: American Society of Civil Engineers.
- Moody, D. W., E. B. Chase, and D. A. Aronson (1986). National water summary 1985 — hydrologic events and surface-water resources. Water-supply paper 2300, U. S. Geological Survey, Washington, D.C.
- Mulholland PJ, Wilson GV, J. P. (1990). Hydrogeochemical response of a forested watershed to storms - effects of preferential flow along shallow and deep pathways. *Water Resources Research* 26(12), 3021–3036.
- Mulvaney, T. (1850). On the use of self-registering rain and flood gauges. *Proceedings of the Institute of Civil Engineers, Dublin, Ireland* 4(2), 1–8.
- National Oceanic and Atmospheric Administration (1977, June). Five- to 60-minute precipitation frequency for the eastern and central united states. NOAA Technical Memorandum NWS HYDRO-35, Silver Spring, MD.
- Nouh, M. (1989). The use of the rational formula in infiltrating mountainous catchments. In *Proceedings of the International Conference for Centennial of Mannings Formula and Kuichling's Rational Formula*, pp. 226–237. Department of Civil Engineering, University of Virginia, Charlottesville, VA.
- Pilgrim, D. H. and I. Cordery (1993). *Handbook of hydrology*, Chapter Flood runoff, chapter 9. McGraw-Hill, Inc.
- Pilgrim, D. H., G. E. McDermott, and G. E. Mittelstadt (1992). The rational method for flood design for small rural basins. In B. C. Yen (Ed.), *Catchment runoff and rational formula*, pp. 16–26. Littleton, Colorado 80161: Water Resources Publications.
- Poertner, H. (1974). *Practices in Detention of Urban Stormwater Runoff*. APWA Special Report No. 43. Washington, D.C.: American Public Works Association.
- R Development Core Team (2007). *R—A language and environment for statistical computing*. Number ISBN 3-900051-07-0. Vienna, Austria <http://www.R-project.org>: R Foundation for Statistical Computing.

- Roussel, M. C., D. B. Thompson, X. Fang, T. G. Cleveland, and A. C. Garcia (2005). Timing parameter estimation for applicable Texas watersheds. Final Project Report 0-4696-2, TxDOT, Lubbock, Texas 79409.
- Sauer, V., W. Thomas, Jr., V. Stricker, and K. Wilson (1983). Flood characteristics of urban watersheds in the United States. Water-supply paper 2207, U.S. Geological Survey, Denver, Colorado.
- Schaake, J. C., J. C. Geyer, and J. W. Knapp (1967). Experimental examination of the rational method. *Journal of the Hydraulics Division, ASCE* 93(6), 353-370.
- Schueler, T. (1987). *Controlling Urban Runoff, A Practical Manual for Planning and Designing Urban BMPs*. Metropolitan Washington Council of Governments.
- Schwab, G. O. and R. K. Frevert (1993). *Elementary Soil and Water Engineering*. Krieger Publishing Company.
- Singh, V. and J. Cruise (1989). A note on the rational method. In *Proceedings of the International Conference for Centennial of Mannings Formula and Kuichling's Rational Formula*, pp. 78-87. Department of Civil Engineering, University of Virginia, Charlottesville, VA.
- Singh, V. and J. Cruise (1992). Analysis of the rational formula using a systems approach. In B. C. Yen (Ed.), *Catchment runoff and rational formula*, pp. 39-51. Littleton, Colorado 80161: Water Resources Publications.
- Smith, A. A. and K.-B. Lee (1984). The rational method revisited. *Canadian Journal of Civil Engineering* 11, 854-862.
- Storey, A., M. Talbott, and S. Fitzgerald (2004). Policy criteria and procedure manual — for approval and acceptance of infrastructure. Policy manual, Harris County Flood Control District.
- Texas Department of Transportation (2009). *Hydraulic design manual* (2009 Revision ed.). Austin, Texas: Texas Department of Transportation.
- Thompson, D. B. (2006). The rational method, regional regression equations, and site-specific flood-frequency relations. Final Project Report 0-4405-1, TechMRT, Texas Tech University, Lubbock, Texas 79409.
- Thompson, D. B. (2007). The rational method, regional regression equations, and site-specific flood-frequency relations. Final Project Report 0-4405-4, Texas Tech University, Lubbock, Texas 79409.
- U.S. Army Corps of Engineers (2006). Hydrologic modeling system HEC-HMS — version 3.1.0. User's manual CPD-74A, Hydrologic Engineering Center, Davis, California.
- Viessman, W. and G. L. Lewis (1996). *Introduction to hydrology* (Fourth ed.). New York: HarperCollins.
- Viessman, W. and G. L. Lewis (2003). *Introduction to hydrology* (Fifth ed.). Prentice-Hall.
- Virginia Department of Transportation (2002). *Drainage Manual*. Richmond, VA.: Commonwealth of Virginia.
- Walesh, S. (1975). Discussion of Chien and Saigal (1975). *Journal of the Hydraulics Division* 101(HY11), 1447-1449.
- Walesh, S. (1989). *Urban water management*. New York, NY: John Wiley & Sons, Inc.

- Wanielista, M., R. Kersten, and R. Eaglin (1997a). *Hydrology: Water quality and quality control*. New York, NY: John Wiley & Sons, Inc.
- Wanielista, M., R. Kersten, and R. Eaglin (1997b). *Hydrology: Water quality and quality control* (2nd ed.). New York, NY: John Wiley & Sons, Inc.
- Wanielista, M. P. and Y. A. Yousef (1993). *Stormwater management*. New York: Wiley-Interscience.
- Ward, G. (2005). Texas water at the century's turn. In J. Norwine, J. Giardino, and S. Krishnamurthy (Eds.), *Water for Texas*. Texas A and M Press.
- Whipple, W. and others. (1983). *Stormwater Management in Urbanizing Areas*. New Jersey: Prentice-Hall.
- WPCF (1969). *Design and Construction of Sanitary and Storm Sewers*. (Manual of Practice 9 ed.). Washington, D.C.: Water Pollution Control Federation.

A. LITERATURE REVIEW

The rational method is used by hydraulic engineers to estimate design discharge for sizing a variety of drainage structures. The method is relatively simple: The peak discharge, Q_p , is equal to the product of the drainage area, A , the rainfall intensity, I , and a runoff coefficient C . The last two terms, I and C , depend on analyst estimates of time-of-concentration and watershed conditions. Furthermore, there is evidence that the runoff coefficient, C , depends on rainfall depth. Thus, the two terms might be correlated and the simple model becomes non-linear.

The modified rational method is an extension of the rational method used to generate a runoff hydrograph for applications where peak discharge is insufficient to execute a design. The peak discharge for a modified rational method hydrograph is the peak discharge produced by application of the rational method. The hydrograph is created using the time of concentration for the time to peak discharge and using twice the time of concentration for the time base of runoff.

The objective of the project is to evaluate appropriate conditions for use of the rational and modified-rational methods for design on small watersheds, evaluate and refine, if necessary, current tabulated values of the runoff coefficient, and construct guidelines for TxDOT analysts for the selection of appropriate parameter values for Texas conditions.

This appendix, a component of the overall project, represents a brief literature review of the rational method organized into three primary themes: the rational method, the characteristic time, and the runoff coefficient. These three principal elements are interrelated in the application of the method for design.

A.1. Introduction

The rational method is a tool for estimating peak (maximum) instantaneous discharge from relatively small drainage areas. The original developer of the rational method is somewhat unclear (Singh and Cruise, 1989, 1992). Kuichling (1889) in the United States and Lloyd-Davies (1906) in Great Britain are thought to be the first to develop the rational method, although Dooge (1957) remarked that Mulvaney (1850) might have been the first to propose this method.

Small drainage area calculations are important because of the pragmatic need for small basin drainage design. They are also important because runoff estimation techniques for large basins are based on summation of small basins acting together. Therefore, in this sense, the foundation for all runoff models is small basin response and the rational method is a common tool in such response estimation.

A.2. Background

The rational method is expressed as,

$$Q_p = C_{std} iA, \quad (\text{A.1})$$

where Q_p is peak discharge (L^3/T), C_{std} is a rational runoff coefficient (dimensionless) determined by the land-use characteristics in the watershed, A is drainage area (L^2), and i is average intensity of rainfall (L^2/T) of a specified frequency (probability) for a duration equal to the characteristic time, T_c (T), of the drainage area. In the U.S., the customary units for the rational method are cubic feet per second (cfs) for Q , inches per hour (in/hr) for i , and acres for A . To be dimensionally consistent, a conversion factor of 1.0083 should be included to convert acre-inches per hour to cubic feet per second; however, this factor is generally neglected¹.

In this document, C_{std} is the standard rational runoff coefficient² that relates the ratio of input volume rate iA to the output volume rate Q_p .

For development of the rational method, it is assumed that:

1. The rainfall is uniform over the drainage area,
2. The peak rate of runoff can be reflected by the rainfall intensity averaged over a time period equal to the characteristic time³ of the drainage area,
3. The relative frequency (probability) of runoff is the same as the relative frequency (probability) of the rainfall used in the equation⁴,
4. The above formula implies that the peak discharge occurs when the entire area is contributing flow to the drainage outlet, that is, the peak flow will occur at the characteristic time T_c after the start of uniform rainfall. A uniform rainfall of a longer duration than T_c will not produce a greater peak flow but will only lengthen the discharge period, and
5. All runoff generation processes are incorporated into the runoff coefficient.

The runoff generation mechanism is illustrated in Figure A.1 for a continuous rainfall where discharge at the watershed outlet increases until an equilibrium value is reached where the excess rainfall rate and the discharge per unit area are equal. This figure in particular illustrates the fourth, [D], assumption, that is that rainfall over a period longer than T_c has no effect on the discharge in the rational method model.

For small urban drainage designs, such as storm drains, the rational method is the common method for peak flow estimation in the United States (McPherson, 1969), despite criticism for over-simplified assumptions. The widespread use of the rational method can be explained by its

¹At most neglecting this dimensional conversion introduces less than 1-percent error in a calculation based on terms with considerable variability.

²The notation C_{std} is unique to this research project, and is intended to indicate “standard” values of the rational runoff coefficient as in current use by the engineering hydrology community. Later in the memorandum the idea of adjusted coefficients is visited in the context of a unique characteristic time for a watershed.

³Typically the time of concentration, T_c .

⁴Thus rare runoff only occurs during rare rainfall events.

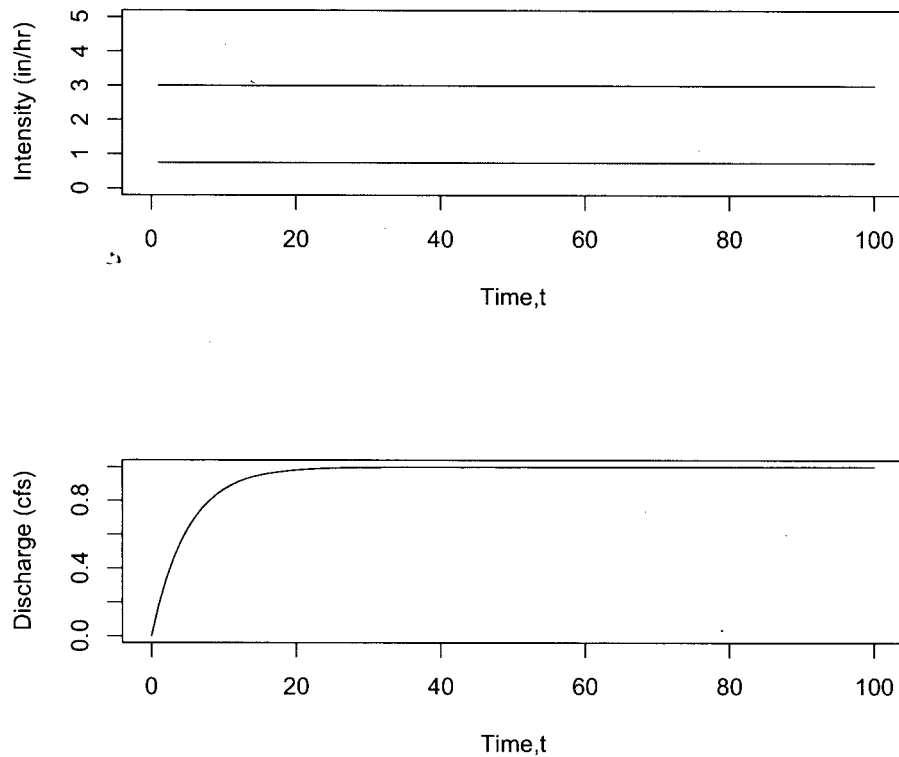

Figure A.1: Runoff generation in rational model. The red line in the upper panel is the excess rainfall intensity, the product of C_{std} , and the raw rainfall intensity. The runoff in the lower panel reaches equilibrium at about 20 time units. The rational method only identifies the equilibrium discharge and does not necessarily produce the shape leading to equilibrium in this diagram.

simplicity, entrenchment in practice, extensive coverage in the literature, and lack of comparable simple-to-use alternatives (Haan and others, 1994).

The applicable area (over which the method can be applied) is generally restricted to less than one square mile (e.g. FHWA (1980)), and in urban areas to less than 20 acres (Poertner, 1974), yet the idea of a runoff coefficient can certainly be extended to large basins⁵. General TxDOT guidance is that the rational method should be applied to watersheds with drainage areas of 200 acres or smaller⁶. The intent of this project is not to examine this particular limitation, although there will

⁵In this context these runoff coefficients are not the same numerically as the rational runoff coefficient, hence the use of the modifier “rational” in this document.

⁶Hydraulic Design Manual, pg. 5-29, TxDOT 3/2004, located at <ftp://ftp.dot.state.tx.us/pub/txdot-info/gsd/manuals/hyd.pdf> at the time of this writing.

be ancillary references to applicable area throughout this literature review. Such issues of scale were addressed in part in TxDOT Project 0–4405.

The rainfall intensity, i , is defined to be the average rainfall rate when the rainfall duration is equal to the time of concentration of the drainage area. In some references the runoff coefficient varies with rainfall intensity i . In Equation A.1, the rainfall intensity is a value selected based on a desired exceedence probability⁷, while the runoff coefficient is a constant property of the watershed. An alternative equation structure is to place probability effects into a frequency correction factor (C_f) as in Equation A.2 (Whipple and others., 1983) that incorporates probability into both the intensity selection as well as the rational runoff coefficient,

$$Q_p = C_{std} C_f i A. \quad (\text{A.2})$$

Both structures are common in the literature and the TxDOT design manual contained a set of frequency corrections in the circa 2002 manual.

The runoff coefficient is a value intended to represent hydrologic abstractions and hydrograph attenuation. The range of the runoff coefficient is [0,1]. When equal to 0, no runoff occurs and when equal to 1, all rainfall is runoff. The runoff coefficient is thought to be a property of the watershed, nevertheless the idea of adjustments to explain circumstances beyond original use are important in the context of this project and an equation similar in structure to Equation A.2 may result from this study⁸.

The watershed characteristic response time is an essential component of the rational method. Issues of timing were examined in detail in TxDOT project 0–4696, although at a larger spatial scale than considered applicable for the rational method. Of great importance for small watershed behavior is the observation that the characteristic time, being in the denominator of the intensity calculation, exerts considerable influence on the sensitivity (change in Q_p for a unit change in T_c) of the calculated peak discharge and especially for smaller watersheds where T_c itself is relatively small.

A.2.1. Modified Rational Method — Background

The rational method was not developed for design problems involving runoff volume, but was originally proposed for estimating peak flowrate for sizing hydraulic structures, such as storm drains and culverts. The modified rational method extends the idea of the rational method to parameterize simple runoff hydrographs (typically triangular), in which the peak of the hydrograph is the peak discharge estimated by application of the rational method and the time base of the hydrograph (start-to-finish of the hydrograph) is twice the time of concentration.

With the intent of using the rational method for hydraulic structures involving storage, the modified rational method was developed (Poertner, 1974). The term “modified rational method analysis” refers to “a procedure for manipulating the basic rational method techniques to reflect the fact that

⁷Exceedence probability is the probability that a particular event will be equalled or exceeded.

⁸In fact such a result is the case in Section 3.

storms with durations greater than the normal time of concentration for a basin will result in a larger volume of runoff even though the peak discharge is reduced” (Poertner, 1974, p. 54). Under this concept, the basic hydrograph is a triangle generated by a rainfall duration D equal to the time of concentration T_c , and with a base equal to $2T_c$.

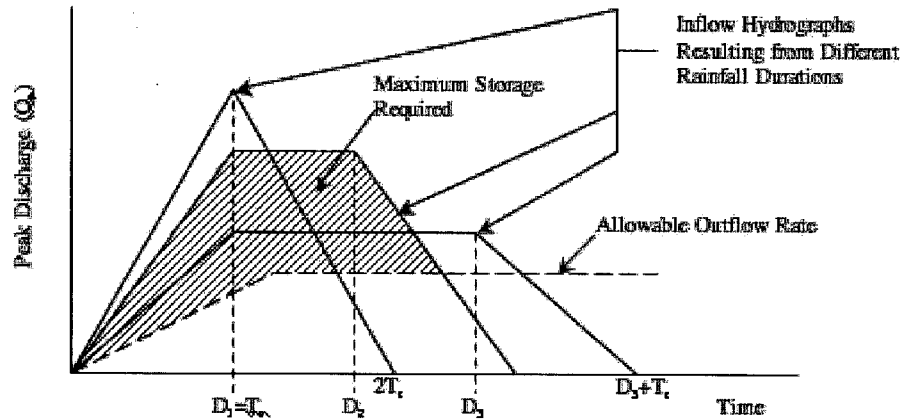

Figure A.2: Modified Rational Formula Hydrographs by Poertner (1974). Adapted from Thompson (2006).

Three inflow hydrograph examples resulting from different rainfall durations are shown on Figure A.2. The peak runoff rate, Q_p , for each hypothetical hydrograph is equal to CiA . The rainfall intensity, i , could be taken from the intensity-duration-frequency curves⁹ or from methods reported in (Asquith and others, 2004). The lengths along the abscissa of the rising limb and falling limb of the hydrograph are set equal to T_c for the drainage basin. If the allowable outflow rate from the detention facility is known (e.g., the pre-development outflow rate), then the critical storage volume is obtained by calculating the area between the inflow and outflow hydrographs, shown as the hatched area in Figure A.2. The example shown in Figure A.2 indicates that the maximum storage required (hatched area) occurs when the rainfall duration is D_2 , which illustrates the importance of the characteristic response time.

A.3. Rational Method Studies

The American Society of Civil Engineers (ASCE) Manual of Practice No. 77 (ASCE, 1992) and the Water Pollution Control Federation Manual of Practice No. 9 (WPCF, 1969) appear to be the most cited documents on the rational method. The tables of rational runoff coefficients in most textbooks trace their origin to these two documents.

Despite its common use, the rational method has many limitations and shortcomings some of which

⁹Commonly called *IDF* curves.

were mentioned in the introduction of this document. These limitations are summarized by FHWA (1980) as follows:

The maximum acceptable size of the watershed varies from 200 to 500 acres (0.90 to 1.422 km²) depending upon the degree of urbanization. The APWA Special Report No. 43 (Poertner, 1974) recommends that urban drainage areas should be limited to less than 20 acres (0.284 km²) in size, such as rooftops and parking lots. As drainage areas become larger and more complex, the C_{std} coefficient cannot account for the many natural hydrological abstractions, surface routing, and antecedent moisture conditions.

In addition to the limitation associated with runoff coefficient, the assumption of same exceedance frequency for both rainfall and runoff is criticized. The storm duration and time of concentration are not necessarily equal in actual hydrologic practice. For small urban drainage basins, the storm duration is normally longer than the time of concentration, and for large watersheds, the time of concentration usually exceeds the storm duration (Singh and Cruise, 1989). As such, using the unaltered rational method for urban drainage design and large, complex watersheds is questionable¹⁰.

The rational method has also been evaluated for infiltrating mountainous basins, that is, basins with high infiltration rate in mountainous areas. Nohu (1989) tested the rational method in small (<200 km²) and large (>4000 km²) infiltrating mountainous basins in Saudi Arabia and concluded that the rational method is not appropriate for application in such basins, particularly if the rational method is used for predicting flows having return periods exceeding two years. The rational method overestimated flowrates and its accuracy varied widely with both catchment and rainfall characteristics.

Over the past century, researchers attempted several innovative approaches evolving from the rational method — the principal goal of these approaches is to retain the simplicity of the rational method while faithfully reproducing observed behavior. A selected review of such studies follows.

Pilgrim and others (1992) used observed flood data to apply the probabilistic approach (Horner and Flynt, 1936) of the rational method for small to medium sized basins in Australia. Equation A.3 is the probabilistic model of the rational method,

$$Q_{(Y)} = C_{(Y)} I_{(T_c, Y)} A, \quad (\text{A.3})$$

where Q is peak discharge, $C_{(Y)}$ is a rational runoff coefficient (dimensionless) associated with a particular recurrence interval (probability), A is drainage area, $I_{(T_c, Y)}$ is average intensity of rainfall for a duration of T_c , the time of concentration, and Y is the average recurrence interval (ARI). In this model, Pilgrim and others asserted that runoff coefficient and rainfall intensity are no longer a fixed value in a given rainfall event for a specific watershed¹¹.

¹⁰In the introduction, the concept that large watersheds are comprised of interconnected small watersheds is discussed. However, in this context with appropriate spatial and temporal transformations a rational method approach could be aggregated into a collective response and thus be appropriate. The authors warn that such an exercise is non-trivial and beyond the conventional meaning of the rational method.

¹¹Equation A.3 is structurally identical to Equation A.2 with $C_{(Y)} = C_{std} C_f$

The intent is to estimate the discharge that would be given for this ARI by a frequency analysis of observed floods if gaging data were available at the site. With this probabilistic interpretation, Pilgrim and others claimed the approach can be valid for basin sizes up to 250 km². An algorithm for deriving required data for the probabilistic rational method is detailed in Maidment (1993).

Chen and Wong (1989) used the kinematic wave approach to evaluate the rational method. They asserted that the runoff coefficient is a function of the rainfall intensity and infiltration and T_c is correlated to physical characteristics of watershed and rainfall intensity. A re-evaluation of the rational method using the kinematic wave approach and rainfall data from Singapore demonstrated that the conventional approach yields greater peak flow rates than the kinematic wave approach. Similarly, Madramootoo (1989) tested the applicability of the rational method to an 8.1 km² watershed in the Quebec, Canada. Madramootoo reported that the runoff coefficient was not constant but varied seasonally; the rational method tended to overestimate peak flows.

Bengtsson and Niemczynowicz (1998) used the time-area method and statistically-derived design storms to calculate the peak flow for complex hypothetical urban drainage systems. Bengtsson and Niemczynowicz reported that the design flow is underestimated using the rational method unless a reduced time of concentration is used. This finding is different from most other studies, in which overestimating peak flow by the rational method is almost a consensus. The hypothetical drainage systems included pipelines in the system, and these hydraulic elements could explain the peak flow overestimation.

A hybrid rational-unit hydrograph method was developed by Chui and others (1994) to simulate storm runoff. They developed a hydrograph simulation method combining the runoff coefficient and the time of concentration in the rational method with the Soil Conservation Service¹² synthetic triangular unit hydrograph. By comparing simulated and observed data for two drainage basins sized 4.4 km² and 6.4 km², Chui and others reported that this hybrid method predicted the observed hydrographs with reasonable accuracy.

Hayes and Young (2005), in cooperation with the Virginia Department of Transportation (VDOT), investigated the reliability of the rational method for estimation of peak streamflow from design storms. At the time of Hayes and Young, the rational method was recommended in the Drainage Manual (Virginia Department of Transportation, 2002) to estimate runoff from small basins with areas up to 200 acres in Virginia. For the study, eight small basins located in central Virginia with drainage areas that ranged from 2.5 to 52.7 acres were instrumented with monitoring devices to measure streamflow and rainfall. These data, in conjunction with land use conditions, were analyzed to estimate times of concentration¹³ and runoff coefficients for individual storms to be compared with design estimates made for each basin.

Design estimates of time of concentration were generally longer and considered less conservative than estimates derived directly from observed data, whereas design estimates of runoff coefficients were generally greater and considered more conservative than estimates derived directly from observed data. Design estimates of peak streamflow were considered more conservative than estimates derived

¹²Now Natural Resources Conservation Service (NRCS).

¹³Hayes and Young considered three computational definitions of time of concentration in their analysis. It is unclear how or whether these definitions were used in the computation of runoff coefficients.

directly from observed data at seven of the eight sites. However, rainfall intensities and durations measured at the eight sites generally had less than a 2-year recurrence interval and did not provide a good comparison for less frequent events. Hayes and Young (2005) concluded that application of the rational method results in overestimates of peak streamflow because of overestimation of the runoff coefficient (larger peak) without an offsetting overestimate of the time of concentration (smaller peak).

Hayes and Young (2005) conclude that there is continued disagreement between researchers regarding the validity of the rational method. The assumptions most disputed with the rational method are uniform precipitation and negligible basin storage. These assumptions become less valid as drainage area increases. Data collected and analyzed for the Hayes and Young study confirm the nonuniformity of precipitation in time and space, and also suggest that unsteady runoff conditions are generated from time-varying rainfall, overland flow, and subsurface stormflow. However, runoff characteristics determined using different methods from multiple storms validate, to a small degree, use of the rational method for peak streamflow estimation for design storms. Further validation would require a flood-frequency analysis of annual peak streamflow.

A.3.1. Modified Rational Method

The rational method was not developed for design problems involving runoff volume, but was originally proposed for estimating peak flowrate for sizing hydraulic structures such as storm drains and culverts. With the intent of using the rational method for hydraulic structures involving volume control, the modified rational method was developed by Poertner (1974), and already discussed in the introduction to this report. A scale limitation of 20 acres for using the modified rational method was suggested by Poertner (1974).

Following the modified rational method concept, Aron and Kibler (1990) changed the assumption of determining the maximum storage volume. They assumed that the maximum storage volume will be reached on the rising limb of outflow hydrograph at the intersection with the recession side of the corresponding inflow hydrograph (Figure A.3). The pond volume can then be computed as

$$V = Q_p D - Q_0 \left(\frac{D + T_c}{2} \right), \quad (\text{A.4})$$

where D is the duration of rainfall, Q_p is the peak runoff rate for D duration, and Q_0 is the maximum allowable discharge. To determine the volume, an iterative process of changing the rainfall duration is required.

Later, Akan (2002) extended the Aron and Kibler (1990) procedure for sizing infiltration basins by combining the rational method with a hypothetical hydrograph. A trapezoidal hydrograph with the peak flow calculated from the rational method was used to estimate the runoff volume required by an infiltration basin. Akan (2002) demonstrated the design process and suggested that this method be used for basin areas less than 8–12 hectares (20–30 acres).

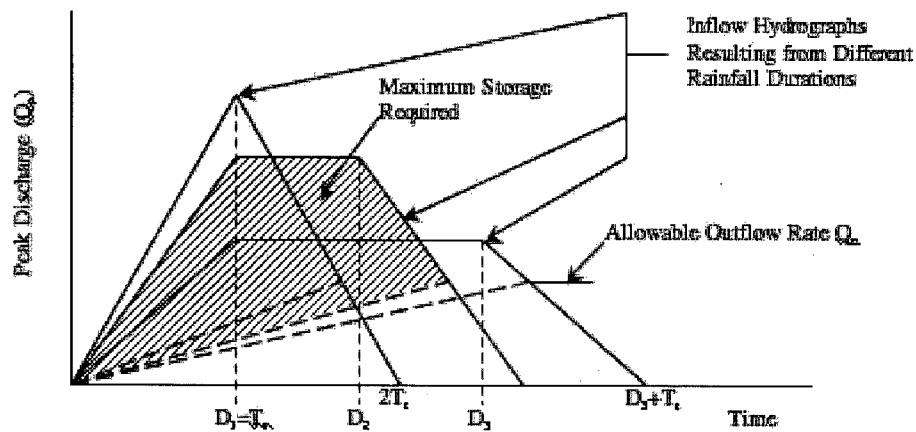

Figure A.3: Modified Rational Formula Hydrographs by Aron and Kibler (1990). Adapted from Thompson (2006).

A.3.2. Concluding Remarks

The TxDOT guidelines for the maximum drainage area for application of the rational method is 200 acres, which is also suggested by FHWA (1980) and ASCE (1992). Although the 200-acre drainage area limit seems to be adopted by state or federal agencies, many researchers applied the rational method to watersheds with drainage areas exceeding 200 acres (see Table A.1) and claim to obtain reasonable results. It is notable that several studies of the rational method on watersheds with drainage areas exceeding 200 acres in fact modified the traditional rational method for design dealing with volume storage, which broadens the use of the rational method beyond the peak rate estimate.

The simplicity of the method and the minimal time/data required make the rational method the most used approach for estimating peak flow in small urban drainage design despite problems associated with the assumptions of the rational method. The modified rational method evolved to treat design problems dealing with volume control. This modified rational method remains easy to apply and may be useful for TxDOT simply to retrofit existing flood control facilities as stormwater quality-control basins. The modified rational method allows iterative but simple calculation for the maximum volume storage required for small drainage watersheds.

Another modified approach for the rational method is the probabilistic model. Application of this method requires observed flood data and more effort to develop probabilistic runoff coefficients for drainage areas up to 250 km² (96.5 mi²). Isolines of runoff coefficients can then be drawn, which in turn can become an applicable product for TxDOT.

A.4. Characteristic Time

Fundamental to the rational method is a characteristic time¹⁴. Mulvaney (1850) introduced the term *concentration time* as a means to specify an appropriate rainfall-averaging interval for peak discharge prediction. At the time (circa 1850) rainfall gages were, for all practical purposes, total depth devices that measured rainfall depth over an entire storm. Without doubt engineers at the time sat through storms and monitored rainfall gages at short intervals (say 15 minutes), but there was no practical means to obtain the temporal rainfall resolution available today. The time of concentration concept was established, at least in part, to choose a time period over which to read rainfall gages for prediction of peak discharge.

Schaake and others (1967) considered the issue of a characteristic time. Quoting from their work:

An assumption of the time required for runoff to flow from the farthest point in the drainage area is presently used in design practice. However, there is no known way to determine this time of flow, either from measurements in the field during storms or from records of rainfall and runoff.

Except for steady state conditions, which rarely, if ever are reached during a thunderstorm, there is no good reason to believe that the time of flow from the farthest point in a drainage area should necessarily be the best rainfall averaging time to use in the Rational Method. A study, therefore, was made to find for each area the averaging time giving the best correlation between average rainfall intensity and peak runoff rates.

This concept that times other than the time-of-concentration can be used is an important degree of freedom for the rational method research and is the linkage between the rational method, modified rational method, and methods appropriate for larger watersheds. The researchers speculate that the limit of 200 acres for rational method application is as much a rainfall averaging-time issue as a land use (C_{std}) issue. This drainage area specification restricts the rainfall-averaging time no greater than one-half hour. This choice of maximum averaging-time is in the region where intensity duration curves from Hershfield (1961) and National Oceanic and Atmospheric Administration (1977) are treated as relatively flat¹⁵.

Guo (2000) used the concept that any catchment can be converted into an equivalent rectangular watershed (FHWA, 1983) and a moving average procedure applied to simulate runoff hydrographs. He examined 44 storms in the Denver, Colorado region and used regression analysis to identify catchment parameters, specifically the requisite characteristic time, T_c . Equation A.5 is the relationship of Guo, rewritten using fractional exponents,

$$T_c = m \times \left(\frac{L^2}{S}\right)^{\frac{1}{3}}, \quad (\text{A.5})$$

¹⁴The characteristic time is used by the writers of this review to distinguish from specific definitions in the literature. Time-of-concentration, time-to-peak, and basin lag time are all characteristic times — they attempt to relate the response of a watershed to a rainfall input in the time domain.

¹⁵*Relatively flat* is a subjective observation by the writers. The IDF curves exhibit curvature for all durations, but intensity declines rapidly as duration is increased

where L is a characteristic length¹⁶, S is dimensionless slope (along that path), m is a constant, thought to be related to land use, and dimensionally it is a reciprocal velocity to the one third power. The structure of this equation is diagnostic — time of concentration scales to the cube-root of area. Guo concludes that the rational method is a special case of a kinematic wave solution — a model strongly dependent on the definition of travel time.

Roussel and others (2005) and Fang and Su (2006) developed similar equations for relating characteristic times to watershed characteristics. Their focus was at spatial scales greater than those for rational method application. Regardless, the structure of their equations is quite similar to Guo (2000), with the exception that the exponent on slope is nearly $\frac{1}{2}$. This result is probably reflective of the geomorphic differences of the eastern slopes of the Rocky Mountains in comparison to central Texas. In fact Schaake and others (1967) also attempted to relate their characteristic time to watershed physical properties and also arrive at similar structured models.

Hayes and Young (2005) considered three computational definitions of time of concentration in their analysis. It is unclear how or whether these definitions were used in the computation of runoff coefficients.

Clearly the characteristic time specification is a crucial issue and methods already in existence can be used; whether the characteristic time is the time-of-concentration as we know it, or some other computable time is to be further clarified in the present research.

¹⁶Main channel length in the current authors' usage.

A.5. The Runoff Coefficient

The rational runoff coefficient is the constant of proportionality that relates rainfall input to discharge output. This portion of the literature review was focused on finding original sources of runoff coefficients in current use from the literature. In the search, two “kinds” of runoff coefficients appear to be in use. The first kind is a runoff coefficient based on small scale and short duration studies — in the present work these are called rational runoff coefficients. The second kind is a coefficient based on water-budgets either over long time periods and/or large spatial scales.

A.5.1. Standard Rational Runoff Coefficients

A list of rational runoff coefficients (in contrast to runoff coefficients for large basins) along with the literature source of the values are presented in Table A.1. Most of the values originate from a single source, the ASCE/WEF manual of practice. Additional values from other sources that appear to be unique are included in the table. There is a considerable range of variability in the undeveloped portion of the table and land use description in the absence of location and other conditions is insufficient. For example, grasslands in the United Kingdom appear to be much better producers of runoff than similar land use in the United States – certainly reflecting geographical differences as well as likely soil and other differences.

Table A.2 lists values of rational runoff coefficients from studies in Baltimore, Maryland adapted from Schaake and others (1967). Schaake and others related the characteristic time as well as the rational runoff coefficient to physical characteristics (length, slope, impervious fraction). The structure of their relationship is that their rational runoff coefficient regression model is shown in Equation A.6,

$$C_{urban} = \beta_0 + \beta_1 IMP_COV + \beta_2 SLOPE. \quad (A.6)$$

Interpretation of this equation by the writers of this report is that Schaake and others considered the rational runoff coefficient to be a constant, possibly related to soil type in the pervious area of their study watersheds, weighted by contribution from impervious cover, and weighted again by the drainage slope.

This approach appears to have been integrated into the C_{std} values in (ASCE, 1992) where the values are associated with typical land use and descriptive slope ranges.

Table A.1: Rational method runoff coefficients for various land uses (Standard C_{std}).

[LAND USE is a predominant land coverage, percentages are longitudinal slopes; C_{std} is the standard rational runoff coefficient; SOURCE is the literature citation from which the numerical values are obtained.

HSG is NRCS hydrologic Soil Group (where indicated); PCP is poor conservation practice; GCP is good conservation practice; IMP_COV is impervious cover (fraction or percent).]

| LAND_USE | C_{std} | SOURCE |
|-------------------------------|-----------|---------------------------|
| Developed Areas | | |
| Business: | | |
| downtown areas | 0.70-0.95 | ASCE (1992) |
| neighborhood areas | 0.30-0.70 | ASCE (1992) |
| Residential: | | |
| single-family areas | 0.30-0.50 | ASCE (1992) |
| multi-units, detached | 0.40-0.60 | ASCE (1992) |
| multi-units, attached | 0.60-0.75 | ASCE (1992) |
| suburban | 0.35-0.40 | ASCE (1992) |
| apartment dwelling areas | 0.30-0.70 | ASCE (1992) |
| 30% IMP_COV, HSG A | 0.30 | Schwab and Frevert (1993) |
| 30% IMP_COV, HSG B | 0.40 | Schwab and Frevert (1993) |
| 30% IMP_COV, HSG C | 0.45 | Schwab and Frevert (1993) |
| 30% IMP_COV, HSG D | 0.50 | Schwab and Frevert (1993) |
| 70% IMP_COV, HSG A | 0.50 | Schwab and Frevert (1993) |
| 70% IMP_COV, HSG B | 0.60 | Schwab and Frevert (1993) |
| 70% IMP_COV, HSG C | 0.70 | Schwab and Frevert (1993) |
| 70% IMP_COV, HSG D | 0.80 | Schwab and Frevert (1993) |
| Industrial: | | |
| light areas | 0.30-0.80 | ASCE (1992) |
| heavy areas | 0.60-0.90 | ASCE (1992) |
| Parks, cemeteries | 0.10-0.25 | ASCE (1992) |
| Playgrounds | 0.30-0.40 | ASCE (1992) |
| Railroad yards | 0.30-0.40 | ASCE (1992) |
| Unimproved areas: | | |
| sand or sandy loam soil, 0-3% | 0.15-0.20 | ASCE (1992) |
| sand or sandy loam soil, 3-5% | 0.20-0.25 | ASCE (1992) |
| black or loessial soil, 0-3% | 0.18-0.25 | ASCE (1992) |

Continued on next page

Table A.1: Rational method runoff coefficients for various land uses (Standard C_{std}). — Continued

| LAND_USE | C_{std} | SOURCE |
|--------------------------------|-----------|--------------------------------------|
| black or loessial soil, 3-5% | 0.25-0.30 | ASCE (1992) |
| black or loessial soil, > 5% | 0.70-0.80 | ASCE (1992) |
| deep sand area | 0.05-0.15 | ASCE (1992) |
| steep grassed slopes | 0.7 | ASCE (1992) |
| Lawns: | | |
| sandy soil, flat 2% | 0.05-0.10 | ASCE (1992) |
| sandy soil, average 2-7% | 0.10-0.15 | ASCE (1992) |
| sandy soil, steep 7% | 0.15-0.20 | ASCE (1992) |
| heavy soil, flat 2% | 0.13-0.17 | ASCE (1992) |
| heavy soil, average 2-7% | 0.18-0.22 | ASCE (1992) |
| heavy soil, steep 7% | 0.25-0.35 | ASCE (1992) |
| Streets: | | |
| asphaltic | 0.85-0.95 | ASCE (1992) |
| concrete | 0.90-0.95 | ASCE (1992) |
| brick | 0.70-0.85 | ASCE (1992) |
| Drives and walks | 0.75-0.95 | ASCE (1992) |
| Roofs | 0.75-0.95 | ASCE (1992) |
| Undeveloped Areas | | |
| Forests | | |
| Beech Forest (New Zealand) | 0.43-0.61 | McDonnell (1990) |
| Rainforest (Amazon) | 0.47 | Lloyd and others (1988) |
| Decidious Forest (Tennessee) | 0.52 | Mulholland PJ (1990) |
| Forest (UK) | 0.28-0.68 | Law (1956), Hydrology (1976) |
| Forest (Germany) | 0.33-0.59 | Caspany (1990) |
| Woodland, sandy & gravel soils | 0.10 | Leopold and Dunne (1978) |
| Woodland, loam soils | 0.30 | Leopold and Dunne (1978) |
| Woodland, heavy clay soils | 0.40 | Leopold and Dunne (1978) |
| Woodland, shallow soil on rock | 0.40 | Leopold and Dunne (1978) |
| Woods, no grazing , HSG A | 0.06 | Schwab and Frevert (1993) |
| Woods, no grazing, HSG B | 0.13 | Schwab and Frevert (1993) |
| Woods, no grazing , HSG C | 0.16 | Schwab and Frevert (1993) |
| Woods, no grazing , HSG D | 0.20 | Schwab and Frevert (1993) |
| Clearings | | |
| Heather (UK) | 0.63-0.72 | Law (1956), Calder and others (1984) |
| Grassland (UK) | 0.70-0.89 | Kirby and others (1991) |
| Pasture, sandy & gravel soils | 0.15 | Leopold and Dunne (1978) |

Continued on next page

Table A.1: Rational method runoff coefficients for various land uses (Standard C_{std}). — Continued

| LAND_USE | C_{std} | SOURCE |
|----------------------------------|-----------|---------------------------|
| Pasture, loam soils | 0.35 | Leopold and Dunne (1978) |
| Pasture, heavy clay soils | 0.45 | Leopold and Dunne (1978) |
| Pasture, shallow soil on rock | 0.45 | Leopold and Dunne (1978) |
| Pasture, grazing, HSG A | 0.10 | Schwab and Frevert (1993) |
| Pasture, grazing, HSG B | 0.20 | Schwab and Frevert (1993) |
| Pasture, grazing, HSG C | 0.25 | Schwab and Frevert (1993) |
| Pasture, grazing, HSG D | 0.30 | Schwab and Frevert (1993) |
| Cultivated, sandy & gravel soils | 0.20 | Leopold and Dunne (1978) |
| Cultivated, loam soils | 0.40 | Leopold and Dunne (1978) |
| Cultivated, heavy clay soils | 0.50 | Leopold and Dunne (1978) |
| Cultivated, shallow soil on rock | 0.50 | Leopold and Dunne (1978) |
| Row Crop, PCP, HSG A | 0.55 | Schwab and Frevert (1993) |
| Row Crop, PCP, HSG B | 0.65 | Schwab and Frevert (1993) |
| Row Crop, PCP, HSG C | 0.70 | Schwab and Frevert (1993) |
| Row Crop, PCP, HSG D | 0.75 | Schwab and Frevert (1993) |
| Row Crop, GCP, HSG A | 0.50 | Schwab and Frevert (1993) |
| Row Crop, GCP, HSG B | 0.55 | Schwab and Frevert (1993) |
| Row Crop, GCP, HSG C | 0.65 | Schwab and Frevert (1993) |
| Row Crop, GCP, HSG D | 0.70 | Schwab and Frevert (1993) |
| Small grain, PCP, HSG A | 0.35 | Schwab and Frevert (1993) |
| Small grain, PCP, HSG B | 0.40 | Schwab and Frevert (1993) |
| Small grain, PCP, HSG C | 0.45 | Schwab and Frevert (1993) |
| Small grain, PCP, HSG D | 0.50 | Schwab and Frevert (1993) |
| Small grain, GCP, HSG A | 0.20 | Schwab and Frevert (1993) |
| Small grain, GCP, HSG B | 0.22 | Schwab and Frevert (1993) |
| Small grain, GCP, HSG C | 0.25 | Schwab and Frevert (1993) |
| Small grain, GCP, HSG D | 0.30 | Schwab and Frevert (1993) |
| Meadow, HSG A | 0.30 | Schwab and Frevert (1993) |
| Meadow, HSG B | 0.35 | Schwab and Frevert (1993) |
| Meadow, HSG C | 0.40 | Schwab and Frevert (1993) |
| Meadow, HSG D | 0.45 | Schwab and Frevert (1993) |

Table A.2: Rational Runoff Coefficients for Baltimore, MD Urban Watersheds. From Schaake and others (1967).

[SITE is the watershed location; AREA is area in acres; IMP_COV is impervious cover fraction; MCL is main channel length in feet; S is dimensionless slope; C_{std} is the standard rational runoff coefficient.]

| SITE | AREA | IMP_COV | MCL | S | C_{std} |
|----------------|-------|---------|-------|--------|-----------|
| Gray Haven | 23.3 | 0.52 | 1,868 | 0.0091 | 0.56-71 |
| Newark 9 | 0.636 | 1.00 | 575 | 0.0335 | 0.85-1.00 |
| Newark 12 | 0.955 | 1.00 | 917 | 0.0068 | 0.83-1.00 |
| Northwood | 47.4 | 0.68 | 2,264 | 0.0287 | 0.66-0.80 |
| Swansea | 47.1 | 0.44 | 2,000 | 0.0306 | 0.51-0.67 |
| Yorkwood South | 10.4 | 0.41 | 1,041 | 0.0351 | 0.53-0.60 |

A.5.2. Runoff Coefficients Based on Water Budgets and Long-Term Basin Scale Studies

One interpretation of the runoff coefficient is that the coefficient represents the ratio of runoff produced to rainfall input. Under this interpretation a valid approach to estimating a runoff coefficient is to use results from water-budget studies.

Moody and others (1986) presents maps of annual precipitation depths and annual runoff depths for Texas based on long-term rainfall-runoff records for watersheds in the state. The ratio of these maps (runoff depth to rainfall depth for a particular location) is a runoff coefficient. Performing such a computation would produce a map similar to Figure A.4, a map of runoff as rainfall fraction for Texas (Ward, 2005).

The coefficients expressed in these maps are for basin scale (100's of square miles) and are based on long-term water balances (that is, long times) and should not be used at small spatial and temporal scales. However, the runoff coefficients are valuable as a check of aggregated behavior.

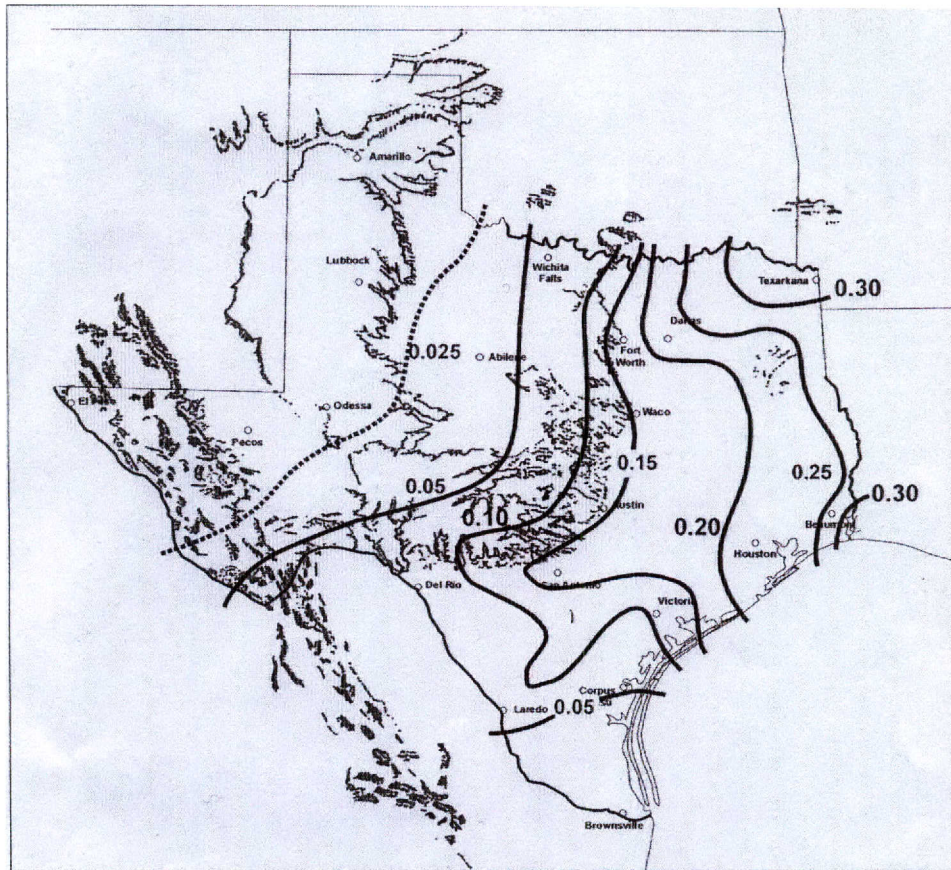

Figure A.4: Runoff Coefficients for Texas from Ward (2005). **Warning:** This figure is not appropriate for drainage design using the rational method at a small spatial or temporal scale — it [the figure] is constructed from basin-scale water budget studies.

A.6. Summary and Conclusions

Based on review of the technical literature, a number of findings are reported.

1. The rational method is used extensively for estimating peak discharge for small drainage basin design. This is in part for its simplicity of application and its widespread acceptance, despite disagreements about its use. The modified rational method extends the method to generate hydrographs for cases where entire hydrographs are needed, such as in detention basin design. The method requires specification of drainage area, a rainfall depth, a characteristic time, and a rational runoff coefficient. Drainage area and to a lesser extent rainfall depth are the least controversial components of the method. The characteristic time used to compute the rainfall intensity (usually from estimates of rainfall depth for a particular duration) and the rational runoff coefficient are, however, the subject of much controversy and uncertainty in application of the method.

2. The original source of C_{std} values (ASCE, 1992) is unclear at the time of this writing. However, the values are consistent with other sources that are traceable to field studies. The research team recognizes the need to collect additional values of C_{std} , but only in a collateral fashion as the project proceeds. The researchers tabulated values from sources for rural upland areas¹⁷. The rational runoff coefficient is strongly dependent on land use and to a lesser extent watershed slope as suggested by both Schaake and others (1967) and ASCE (1992).
3. The specification of characteristic time is essential for the intensity calculation and probably as important as C_{std} because it is this time that defines the rainfall averaging interval for computing discharge.
4. The modified rational method shares the C_{std} and the need for a specification of a characteristic time, but generates entire hydrographs. It appears simpler than unit hydrograph methods, but is in fact a special case of a unit hydrograph, at least in the context that it [modified rational] convolves runoff information. There is convincing evidence in the literature that properly parameterized and interpreted the rational method is a special case of kinematic wave modeling and hence the agreement in several studies cited here with rational and other runoff models is not surprising.

In conclusion, the rational method cannot be applied in absence of a characteristic time. Times other than the conventional time-of-concentration were occasionally reported in the literature, thus a characteristic time other than time-of-concentration may be appropriate. The researchers believe that the literature and their own preliminary efforts supports the need to establish a unique and defensible characteristic time. In analysis of well over 10,000 storms (not all within Texas) they found that for many, but not all, there exists a characteristic time where a runoff coefficient computed on intensity and volume ratios are equal. In their opinion, these cases represent situations where the equilibrium conditions for that watershed were satisfied (e.g. the right part of Figure A.1). Interestingly this characteristic time is usually close to a time determined from the square root of drainage area, and, in the absence of other measures, this value of time is considered a good first-order estimate of the appropriate time for rational method analysis.

Once a time base is established, then the specification of the rational runoff coefficient is needed. Runoff coefficients can be specified at large scales, but are water-budget based and will likely result in underestimates at an event time scale and small watershed spatial scale. Nevertheless the idea of a map of lower and upper range of coefficients is appealing, and may be a useful result of this research¹⁸. Limited small watershed studies may provide insight on the rational runoff coefficient, but there are comparatively few studies in the literature from small watersheds aimed at rational runoff coefficient specification. Again, the researchers are pursuing the idea of a standardized value for different land coverage conditions, with adjustments for slope, drainage features, and other physical changes — along the lines of Schaake and others (1967). One useful outcome of this exercise will be to populate the literature with at least one study where the use of rainfall-runoff data was directly applied to the specification of rate-based and volume-based runoff coefficients.

¹⁷These are marginally useful in Texas. The climates for the rural non-U.S. studies receive more precipitation than all areas of Texas with the exception of the eastern portion of the state. However, the values reported probably add to the useful range of estimates

¹⁸Such a thought from early in the research is manifested in Section 3

B. BASIN DEVELOPMENT FACTOR

The basin-development factor *BDF* is a factor used to classify, with a seemingly semi-continuous variable, the degree of watershed development with out direct inclusion of impervious cover. This Appendix describes the *BDF* as use in Appendix C. In general, *BDF* does not contribute to formal conclusions presented in the body of the report.

The *BDF* is conceptualized as a measure of runoff transport efficiency of a watershed containing interconnections of various drainage systems (constructed or otherwise). The *BDF* is a 0–12 point, categorical variable that is a scored representation of the presence of various development conditions (scored 1 through 3) on each third of a watershed. Although a categorical variable, the *BDF* is treated as a continuous variable in a multi-linear regression context herein. Values for *BDF* are defined by dividing the watershed into thirds (Figure B.1) and evaluating each third with respect to four indices of urbanization.

The *BDF* is considered by Sauer and others (1983) in the context of estimation of urban flooding potential and is shown to be a useful predictive variable for that purpose. The *BDF* description that follows is a near verbatim quote by Sauer and others (1983, p. 8), who state:

The most significant index of urbanization that resulted from [the 1983] study is a basin-development factor (*BDF*), which provides a measure of the efficiency of the drainage system. This parameter, which proved to be highly significant in the regression equations [of the 1983 report], can be easily determined from drainage maps and field inspections of the drainage basin. The basin is first divided into thirds as [shown in Figure B.1]. Then, within each third, four aspects of the drainage system are evaluated and each assigned a code as follows:

1. CHANNEL IMPROVEMENTS — If channel improvements such as straightening, enlarging, deepening, and clearing are prevalent for the main drainage channels and principal tributaries (those that drain directly into the main channel), then a code of 1 is assigned. Any or all of these improvements would qualify for a code of 1. To be considered prevalent, at least 50 percent of the main drainage channels and principal-tributaries must be improved to some degree over natural conditions. If channel improvements are not prevalent, then a code of zero is assigned.
2. CHANNEL LININGS — If more than 50 percent of the length of the main drainage channels and principal tributaries has been lined with an impervious material, such as concrete, then a code of 1 is assigned to this aspect. If less than 50 percent of these channels is lined, then a code of zero is assigned. The presence of channel linings would obviously indicate the presence of channel improvements as well. Therefore, this is an added factor and indicates a more highly developed drainage system.

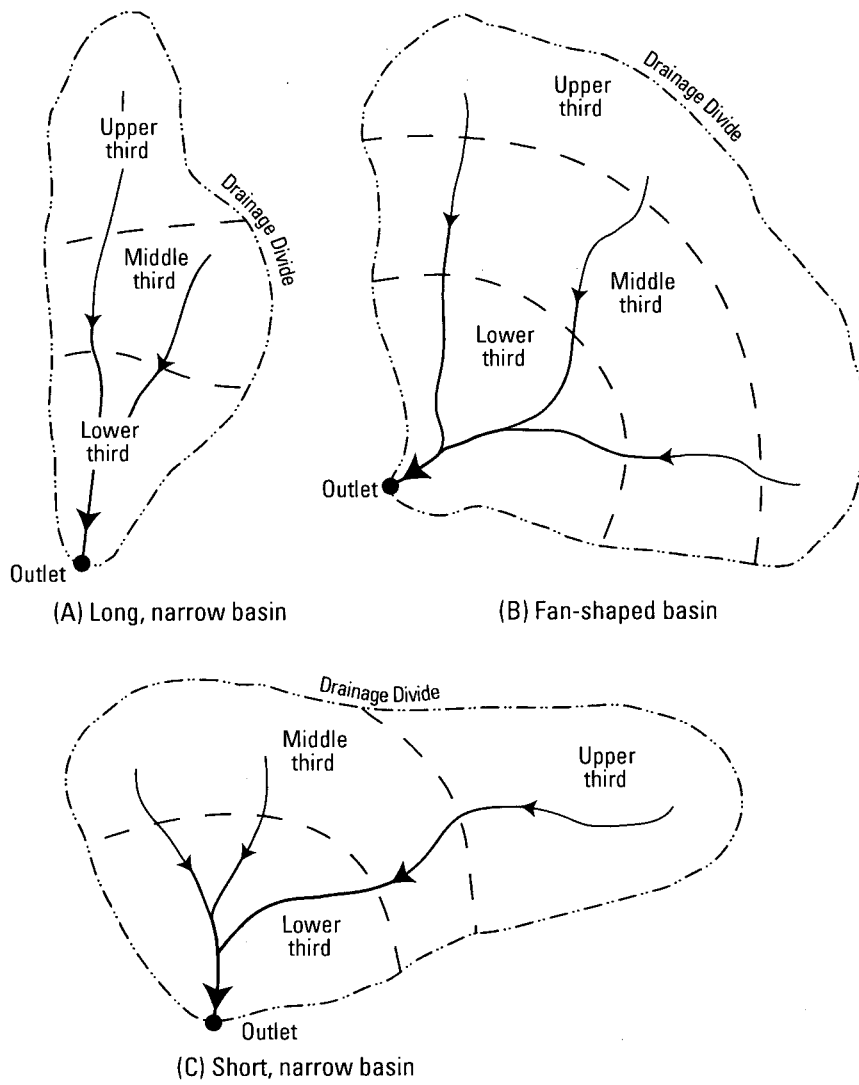

Figure B.1: Schematic of typical drainage basin shapes and subdivision into basin thirds.

3. **STORM DRAINS, OR STORM SEWERS** — Storm drains are defined as enclosed drainage structures (usually pipes), frequently used on the secondary tributaries where the drainage is received directly from streets or parking lots. Many of these drains empty into open channels; however, in some basins they empty into channels enclosed as box or pipe culverts. When more than 50 percent of the secondary tributaries within a subarea (third) consists of storm drains, then a code of 1 is assigned to this aspect; if less than 50 percent of the secondary tributaries consists of storm drains, then a code of zero is assigned. It should be noted that if 50 percent or more of the main drainage channels and principal tributaries are enclosed, then the aspects of channel improvements and channel linings would also be assigned a code of 1.
4. **CURB-AND-GUTTER STREETS** — If more than 50 percent of a subarea (third) is urbanized (covered by residential, commercial, and/or industrial development), and if more than 50 percent of the streets and highways in the subarea are constructed with curbs and gutters, then a code of 1 would be assigned to this aspect. Otherwise, it would receive a code of zero. Drainage from curb-and-gutter streets frequently empties into storm drains.

The above guidelines for determining the various drainage-system codes are not intended to be precise measurements. A certain amount of subjectivity will necessarily be involved. Field checking should be performed to obtain the best estimate. The basin-development factor (*BDF*) is the sum of the assigned codes; therefore, with three subareas (thirds) per basin, and four drainage aspects to which codes are assigned in each subarea, the maximum value for a fully developed drainage system would be [$BDF = 12$]. Conversely, if the drainage system were totally undeveloped, then a *BDF* of zero would result. Such a condition does not necessarily mean that the basin is unaffected by urbanization. In fact, a basin could be partially urbanized, have some impervious area, have some improvement of secondary tributaries, and still have an assigned *BDF* of zero. As is discussed later in [the 1983 report], such a condition still frequently causes peak discharges to increase.

The *BDF* is a fairly straightforward index to estimate for an existing urban basin. The 50-percent guideline will usually not be difficult to evaluate because many urban areas tend to use the same design criteria, and therefore have similar drainage aspects, throughout. Also, the *BDF* is convenient for projecting future development. Obviously, full development and maximum urban effects on peaks would occur when $BDF = 12$. Projections of full development or intermediate stages of development can usually be obtained from city engineers.

A basin-development factor was evaluated for each of the 269 sites used in [the 1983] study. Approximately 30 people were involved in making these evaluations, using guidelines similar to the ones described in the preceding paragraphs but somewhat less explicit. Tests have not been made to see how consistently two or more people can estimate the *BDF* for a basin. However, this study indicates that fairly consistent estimates can be made by different people. A relatively large group of individuals made the estimates for this study and the parameter was statistically very significant in the regression equations. If the results obtained by various individuals had not been consistent, it is doubtful that the statistical results [reported in the 1983 study] would be so significant.

The authors note that values of the *BDF* change with urbanization, and therefore *BDF* values likely should be redefined whenever significant changes take place within a watershed. Further, because two of the authors (Asquith and Cleveland) recently participated in a study focused on watersheds in the Houston, Texas, metropolitan area, select modifications to the method of *BDF* computation

by Sauer and others (1983) were needed¹. Modifications to the method were deemed important in order to account for conditions commonly encountered in the Houston metropolitan area. These modifications consider: (1) the presence of enclosed channels and (2) the prevalence of roadside ditch drainage in a particular watershed.

The following discussion presents suggested modifications to the *BDF* method previously described. These modifications were used for the Houston-area watersheds considered for this investigation. The four “aspects” of Sauer and others (1983) are summarized and the modification shown in italic type.

1. CHANNEL IMPROVEMENTS — If channel improvements such as straightening, enlarging, deepening, and clearing are prevalent for the main drainage channels and principal tributaries, then a code of 1 is assigned. Otherwise, a code of 0 is assigned *unless one of the following applies*:
 - *If 50 percent or more of the main drainage channel and/or principal tributaries are enclosed (for example by storm sewers), then a code of 1 should be assigned.*
 - *For areas with roadside ditch drainage that satisfy the 50 percent or more criteria, a code of 0.5 is assigned. in lieu of the normal value of 1.*
2. CHANNEL LININGS — If more than 50 percent of the length of the main drainage channel and principal tributaries has been lined with an impervious material such as concrete, a code of 1 is assigned. Otherwise, a code of 0 is assigned *unless one of the following applies*:
 - *If 50 percent or more of the main drainage channel and/or principal tributaries are enclosed (for example by storm sewers), then a code of 1 should be assigned.*
 - *For areas with roadside ditch drainage that satisfy the 50 percent or more criteria, a code of 0.5 is assigned. in lieu of the normal value of 1.*
3. STORM SEWERS — If more than 50 percent of the main channel and secondary tributaries are enclosed as storm sewers, a code of 1 is assigned. Otherwise, a code of 0 is assigned.
 - *In the absence of channels (conventional open-channels), the main trunk of the storm sewer system is treated as a “lined” channel for the purposes of scoring the CHANNEL LININGS aspect.*
 - *In the absence of channels (conventional open-channels), the main trunk of the storm sewer system is scored as CHANNEL IMPROVEMENT.*
4. CURB-AND-GUTTER STREETS — If more than 50 percent of a third is urbanized, and if more than 50 percent of the streets and roads within the area are constructed with curbs and gutters, a code of 1 is assigned. Otherwise, a code of 0 is assigned.

¹Fred Liscum, written commun., 2008.

C. THE IPAR PROGRAM AND PARSING OF RAINFALL AND RUNOFF EVENTS

A computer program is described in this Appendix that was used to provide for large-scale storm-by-storm solution of the rational method equation for runoff coefficient. The results of the program are described and the terminal points of the analysis are described before the leap to the analysis described in Section 3. In particular, the core result of this program is eq. 3.3. This analysis is part of the broader research into the rational method. It was conducted to develop understanding of the statistical structure of runoff coefficients for the development of guidance in the use of the rational method by design engineers.

C.1. Inverting the Rational Method

The rational method can be inverted and a solution for the runoff coefficient derived, provided appropriate rainfall-runoff data are available. If rates are used to represent the discharge and rainfall, then the resulting estimates of the runoff coefficient are rate based. This approach provides a runoff coefficient which is consistent with the manner in which the method is applied — namely that an average rainfall rate over a specific duration is used to estimate the peak discharge, which is a runoff rate.

The rational method was inverted and was applied to selected Texas watersheds and small agricultural watersheds located outside Texas. The expanded Texas watersheds includes paired rainfall-runoff data from the Houston region (lower slope, coastal plains) and paired rainfall-runoff data obtained from the Agricultural Research Service (ARS) archives representing events observed on generally small field-scale watersheds. The ARS data were selected by the research team based on availability of time series that could be parsed into sub-hourly data, research watersheds smaller than one square mile in drainage area, and with average watershed slopes comparable to Texas.

In addition to these rainfall-runoff data, certain watershed characteristics also were estimated, and these characteristics include:

1. Total Drainage area (TDA) in square miles (and other units by appropriate conversions),
2. Main Channel Length (MCL) in miles,
3. Dimensionless slope (SLOPE),
4. Basin Development Factor (BDF),

5. Percent Impervious Cover (PERCENT_IMPCOV),
6. Percent Developed (PERCENT_DEVL),
7. Channels (CHANNELS) (a binary variable),
8. Channel Score (CHANNEL_SCORE) (a categorical variable), and
9. Location.

These characteristics were used in a statistical analysis to examine what explanatory value they possess to estimate runoff coefficients¹. USGS personnel constructed the *iPAR* (*i*nteractive *PAR*ser) program to facilitate the analyst-directed inversion of real storms to generate runoff coefficients. Using the *iPAR* program allows the analyst to select subsets of the time series in the individual data files to be treated as separate episodes (events).

C.1.1. The Rational Method for Real Storms

The rational method implemented in and studied using the *iPAR* program is

$$Q_p^{[\text{cfs}]} = CI^{[\text{iph}]}A^{[\text{acre}]}, \quad (\text{C.1})$$

where $Q_p^{[\text{cfs}]}$ is peak discharge in cubic feet per second (cfs), C is the rational coefficient, $I^{[\text{iph}]}$ is rainfall intensity in inches per hour (iph), and $A^{[\text{acre}]}$ is drainage area in acres. The equation is deceptively simple, but subtleties exist in interpretation of the equation when used in a hind-casting mode — that is, the equation is fit to observed time series of rainfall and runoff data (real storms). A “fit rational method” means that the equation is solved for the C value:

$$C = \frac{Q_p}{IA}. \quad (\text{C.2})$$

The equation is elementary: Q_p and A are known quantities, but what about I ?

Rainfall intensity is defined as the ratio between total rainfall P and a characteristic duration t (an unknown quantity) or

$$I = P/t. \quad (\text{C.3})$$

For application of the rational method, conventionally the “time of concentration” T_C of the watershed is used ($t_d \equiv T_C$), and this time is defined as the time required for a parcel of water to travel from the most hydraulically distal point of the watershed to the output. The outlet is a known location, but often the “most hydraulically distal point” is not known or otherwise obvious. Even if the length of the flow path can be reliably estimated, the travel speed is not.

The authors observe that I is dependent on time when calculated from known P (perhaps a design storm), but in a hind-casting mode total rainfall is itself dependent on time. Therefore, because adjustments in t result in presumable changes in I , the C computed is itself dependent on t . The authors observe that:

¹The location information would also allow the use of a GIS-type analysis in the same manner as in the modified rational method of the previous section.

The values for C can not be decoupled from values for t .

Because storms do not last forever and water exits real watersheds, that is, some runoff does not contribute to peak streamflow for $t \gg T_c$, it is logical to conclude that as estimates of $t \rightarrow \infty$ that $I \rightarrow 0$. Hence for the equality of equation C.2 to remain, the C as a function of t results in $C(t) \rightarrow \infty$ as $I \rightarrow 0$.

A necessary step in using the rational method in a hind-casting mode is to “parse” the individual time series of rainfall and runoff into “discrete” events. The rainfall- and runoff-parsing process generally requires the judgment of the analyst, and for the results reported here, analyst judgment was used. The parsing process was made by William Asquith and Meghan Roussel² using a custom-built and highly specific interactive parsing software program iPAR written by Joseph Vrabel.³

Typically the parsing of the runoff event is slightly easier than parsing the rainfall event. The runoff event from small watersheds typically starts from zero or effectively zero streamflow and returns to similar flow conditions during relatively short intervals (hours). For convenience, straight-line baseflow separation commonly was made for this investigation after the runoff was parsed. Further, the rainfall-signal integration process performed by the watershed results in a considerably smoother signal (the hydrograph) than the unrestricted pulses or periods of rainfall.

Depiction of the rainfall- and runoff-parsing process in the context of a hind-casting mode of the rational method is shown in figure C.1 illustrated by William Asquith (USGS, written commun. 2008). In the figure, the “event” windows of t_{PiPAR} and t_{RiPAR} for the rainfall and runoff, respectively, are shown. The analyst for both rainfall and runoff has over-selected or buffered the event of interest—see the lengths t_{zp1} and t_{zp2} (zero-depth padding on rainfall) and t_{zq1} and t_{zq2} (lengths perhaps beyond the runoff hydrograph). The authors explicitly show some over-selection error so as to draw contrast with idealized rainfall and runoff relations shown in textbooks. (The authors also acknowledge in many parsing operations that under-selection error also can occur.) This idealized relation is commonly shown as excess rainfall and baseflow-separated runoff (quickflow) in textbooks (Dingman, 2002, p. 400). The parsing of real rainfall and runoff time series often is an ambiguous process. Recalling the over-selection error, readers are encouraged to compare figure C.1 with figure C.2. Figure C.2 shows the parsing of a selected event from data files of rainfall (top plot) and runoff (bottom plot) from the database described by Asquith and others (2004). The white windows on each time series shows the analyst parsing of the event. Emphasis is made that the rainfall depicted in figure C.1 is distinguished between effective and noneffective (loss) rainfall.

To continue, following the parsing runoff data, the extraction of the peak discharge Q_p and time-of-peak $t(Q_p)$ is comparatively straightforward. Because the drainage area A is a given quantity, the conceptual hurdle remaining with the hind-casting mode of the rational method is the computation of maximum rainfall intensity $I(t_d)$ as function of a characteristic time t_d .

A long-standing rule-of-thumb within the Texas infrastructure design community is that the square root of drainage area in square miles estimates a characteristic watershed time in hours. The square-root-of-area rule provided a critical starting point for an investigation of the rational method.

²USGS, written commun., 2009.

³USGS, written commun., 2008.

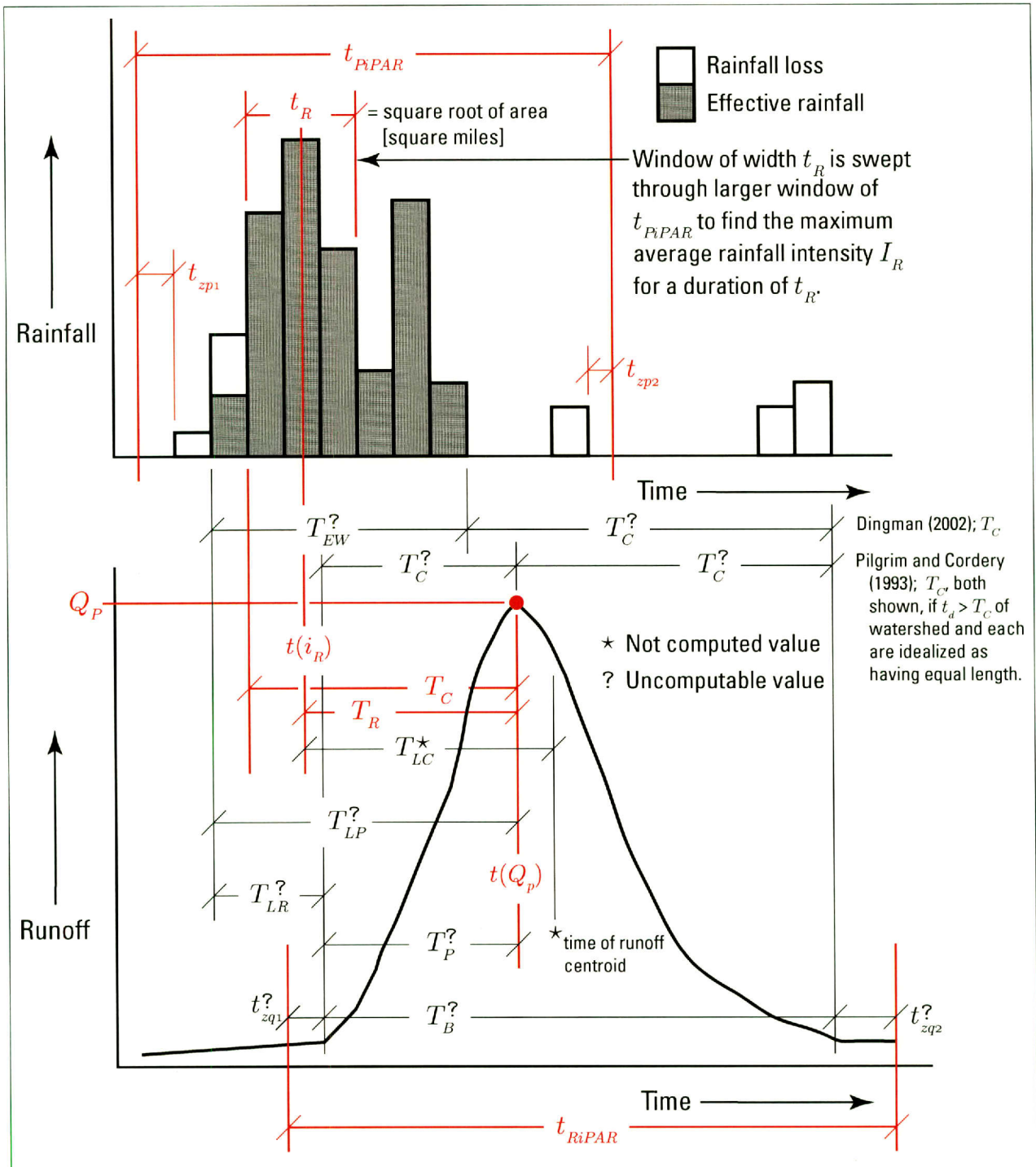

Figure C.1: Overview of the rainfall- and runoff-parsing process using the iPAR program inclusive of definitions of selected metrics and **computational** versus conceptual availability with a specific focus on the square-root-of-area rule for first order estimation of time of concentration.

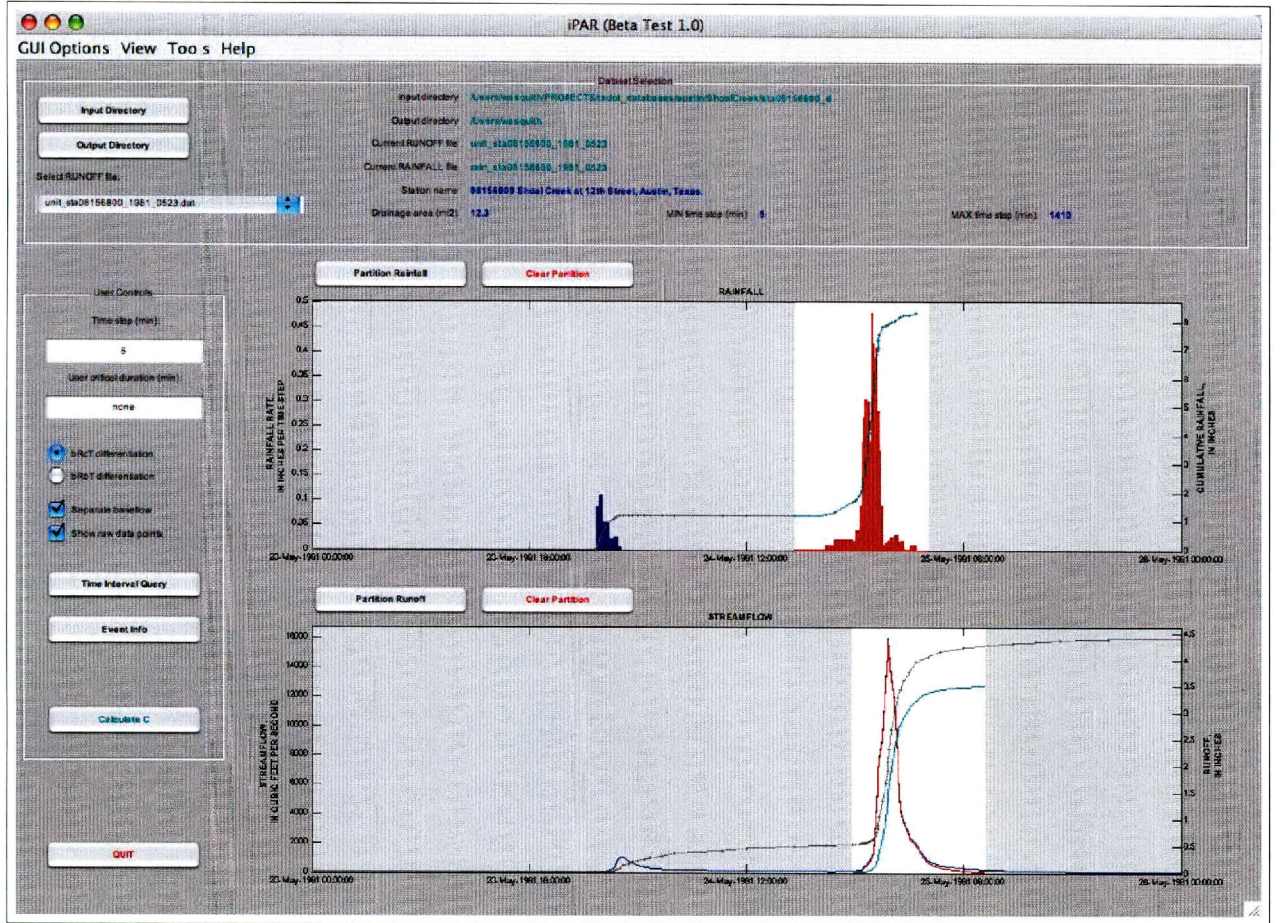

Figure C.2: Screenshot of custom-built iPAR program used to parse a historically significant flood event at U.S. Geological Survey streamflow-gaging station 08156800 Shoal Creek at 12th Street, Austin, Texas, May 24, 1981, which has a drainage area of about 12.3 square miles. The top plot shows the incremental rainfall and the bottom plot shows the resultant runoff hydrograph.

The modified rational method analysis presented in section 2.2.2 independently and unintentionally supports the use of this rule-of-thumb. The unit hydrograph results whether using a curvilinear unit hydrograph or rational unit hydrograph parameterized by the Kerby-Kirpich or $\sqrt{A}^{\text{[sqmi]}}$ (square-root-of-area rule; sqmi, square miles) estimates were barely distinguishable in the holistic sense. In mathematical notation is square-root-of-area rule for t_d and T_R in hours (hrs) is:

$$t_d \equiv t_R^{\text{[hrs]}} = \sqrt{A^{\text{[sqmi]}}}. \quad (\text{C.4})$$

This time window is shown in Figure C.1 as t_R (note lower case t). This window has been swept through the large window T_{PiPAR} as the maximum average intensity has been computed. The center of the t_R window is at time $t(I_R)$. The difference between this time and the time-of-peak $t(Q_p)$ is the length T_R (Time-R), which represents a conventional definition of watershed lag time.

Conceptually, T_R represents a *fundamental, measurable, and unambiguous*⁴ timing parameter as opposed to the other time metrics shown in figure C.1, which each are problematic to compute in the hind-casting mode of the rational method. T_R is not theoretically the only time metric that can be computed; the lag-to-centroid T_{LC} could ideally be computed, but the time-of-runoff centroid can be ambiguous because of dependency on the reliability of the runoff hydrograph being properly parsed.

A conclusion is made that T_R is the most numerically identifiable time in contrast application of more complex unit-hydrograph methods (Asquith and Roussel, 2007) to the rational method that involve temporally distributed rainfall losses. In unit-hydrograph methods, the metrics of time base T_B or T_P of the unit hydrograph can be computed. Furthermore, other common time metrics of the rainfall and runoff process such as time-width of effective rainfall T_{EW} , lag-response T_{LR} , and lag-to-peak T_{LP} are dependent on knowledge of the beginning (and end) of effective rainfall. Such knowledge is nonexistent with the hind-casting mode of the rational method. Finally, the figure also shows three definitions of T_C . The fact that at least three definitions of T_c exists shows the ambiguity of computing T_c from observed hydrographs.

No mathematically tractable definition of T_c seems evident within the hind-casting mode of the rational method.

Although the researchers consider T_R as fundamental characteristic time, it nevertheless is dependent on the assumption that the square-root-of-area rule provides a first-order approximation to the unknown T_c of the watershed. The authors observe that within the window t_{PiPAR} that there are many other candidate rainfall durations from a minimum step Δt (typically 5 minutes for this investigation) up to a duration equal to t_{PiPAR} . Each window was swept in increments of Δt through the parsed rainfall to determine the maximum intensity for the given duration, and the rational method was solved for the runoff coefficient. Example results of these computations for the parsed event in figure C.2 are shown in figure C.3.

The $C(t_d)$ (C as a function of t_d , notationally C_i) in Figure C.2 shows that in general as t_d increases that $C(t_d)$ also increases. The figure also distinguishes between C_V (volumetric runoff coefficient) and C_W (runoff coefficient for full width of parsing window). The C_R value (upside down triangle at 3.5 hours) represents the runoff coefficient for the square-root-of-area rule.

C.1.2. Regression of Time-R (Lag Time)

Analysis of the statistical relation between the median T_R (lag time, Time-R) by watershed and selected watershed characteristics was made. The T_R values were derived, using the square-root-of-area rule, from a large application of the rainfall- and runoff-parsing process. Because precise interpretation of the rational method is highly dependent on timing, statistical regionalization of T_R is an important objective. The purpose of regionalization is to provide an easy-to-use equation for estimation of T_R at small ungaged watersheds in Texas.

For the goal of regionalizing T_R , a total of 11,041 storms were parsed for selected 185 watersheds

⁴Unambiguous to the extent that the rainfall duration or characteristic time t_d is justifiable.

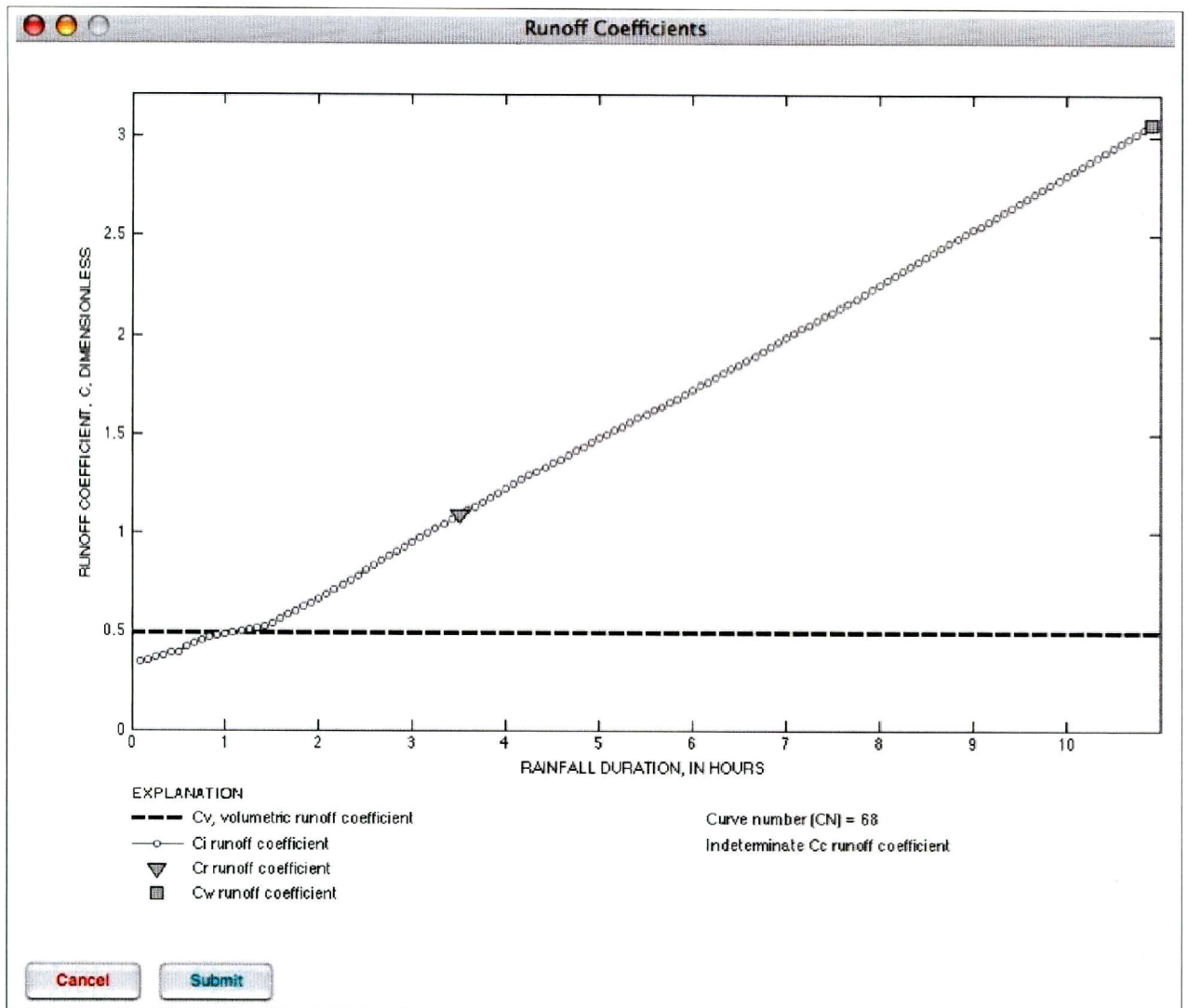

Figure C.3: Screenshot of output for parsed storm in Figure C.2 that shows the relation between runoff coefficient of rational method computed in hind-casting mode and rainfall duration (characteristic time) for each successively-incremented and aggregated, 5-minute window, which has been slid through the parsed rainfall (white window in top plot of figure C.2) to determine maximum rainfall intensity for indicated duration. Notice that runoff coefficient increases as duration increases. Of particular interest for this study are the volumetric runoff coefficient (dashed line) and the runoff coefficient $C_R(t_R)$ based on $t_R = \sqrt{A[\text{sqmi}]}$ (square-root-of-area rule; sqmi, square miles). For this parsed event, $C_V = 0.49$, $C_R = 1.09$, $T_R = 2.21$ hours (Time-R, lag time, a time not shown on the plot).

gaged by U.S. Geological Survey (primarily and all in Texas) or Agricultural Research Service (most outside of Texas). A summary of basic statistics of drainage area A and dimensionless main-channel slope S watershed characteristics for the 185 watersheds is:

| Summary of Drainage Area in square miles | | | | | |
|---|-------------|--------|---------|-------------|----------|
| Minimum | 1stQuartile | Median | Mean | 3rdQuartile | Maximum |
| 0.0032 | 0.4270 | 3.5800 | 11.6500 | 11.5000 | 182.0000 |
| Summary of dimensionless main-channel slope | | | | | |
| Minimum | 1stQuartile | Median | Mean | 3rdQuartile | Maximum |
| 0.0005 | 0.0024 | 0.0069 | 0.0158 | 0.0126 | 0.2058 |

For each of the 185 watersheds, the station-specific, median T_R value was computed, and these 185 values were used as the response variable in subsequent linear regression analysis described in the remainder of this section.

Extensive exploratory analysis, evaluation of various transformations and regression configurations, and experimentation with both generalized linear and generalized additive models were conducted. The analyses were made with the purpose of developing a parametric, algebraic equation for estimation of T_R from readily available watershed characteristics. The analysis was not conducted in a linear (start to finish) fashion and considerable iterations were required in order to develop the equation reported in this section.

Conceptually the basin-development factor (BDF) is a factor variable and prior to developing the equation reported here, a structurally similar regression was developed using BDF as a factor. The thirteen regression coefficients on BDF were extracted and an ordinary-least squares regression between the coefficients and BDF was made. The regression resulted in a coefficient on BDF of $\overline{BDF} = -0.0401$, which states that "on average" T_R decreases by about 4 percent of a log-cycle per unit increase in BDF . The product $BDF \times \overline{BDF}$ was subsequently used as a continuous variable (a non-factor variable) in the final regression.

The final weighted-least squares regression, using weight factors derived from the number of storms per station, on base-10 logarithm of T_R , base-10 logarithm of A , a right-hand-only, broken-stick regression (piecewise linear regression) on S at $S=0.002$, a continuous variable for BDF , and factor variables for Houston-area and Agricultural Research Service watersheds is shown along with selected diagnostics in the following R output (R Development Core Team, 2007):

```
Call:
lm(formula = log10(TR) ~ log10(A) + logSrhs + BDFgrowthB +
    isHouston + isARS,
    data = STATION, weights = MLRweights(W))

Residuals:
    Minimum    1stQuartile      Median  3rdQuartile     Maximum
-0.484118   -0.071043  -0.003039    0.066285    0.404551

Coefficients:
                Estimate Std. Error t-value Pr(>|t|)
(Intercept)   -1.64753    0.08381  -19.658 < 2e-16 ***
log10(A)       0.54221    0.01707   31.763 < 2e-16 ***
```

```

logSrhs          0.26969    0.04056    6.650 3.44e-10 ***
BDFgrowthB      1.04860    0.17138    6.119 5.80e-09 ***
isHoustonyes houston 0.39135    0.05615    6.969 5.89e-11 ***
isARSyes ars     0.32591    0.05369    6.070 7.46e-09 ***
---
Signif. codes:  0 "****" 0.001 "***" 0.01 "*" 0.05 "." 0.1 " " 1

Residual standard error: 0.1424 on 179 degrees of freedom
Multiple R-squared: 0.8773, Adjusted R-squared: 0.8739
F-statistic: 256 on 5 and 179 DF, p-value: < 2.2e-16
# Abbreviations
# Std.Error = Standard error
# t-value    = The t-statistic of the regression
# Pr(>|t|)   = Probability level of absolute value of t-value
# Signif.    = Significance

```

Summary statistics of the residuals in base-10 logarithm units are reported in the output. The statistics show that the residuals are symmetrically distributed at least through the interquartile range, but are heavy-tailed in the distal regions of the distribution. Residuals and selected other diagnostic plots of the regression are shown in Figure C.4. The tail-heaviness of the residuals is shown in the plot in the upper right of the figure. The residuals (upper and lower left plots) also show some slight curvature but extensive iterations in the model-building process failed to develop demonstratively better and easy-to-use models.

Finally, to augment the reporting of the regression, an analysis of variable table (ANOVA) for the final T_R regression equation follows:

```

Response: log10(TR)
      Df Sum Sq Mean Sq F-value Pr(>F)
log10(A)  1 19.6441 19.6441 969.354 < 2.2e-16 ***
logSrhs   1  3.4478  3.4478 170.135 < 2.2e-16 ***
BDFgrowthB 1  1.0890  1.0890  53.736 7.615e-12 ***
isHouston  1  1.0083  1.0083  49.754 3.670e-11 ***
isARS     1  0.7466  0.7466  36.843 7.463e-09 ***
Residuals 179  3.6275  0.0203
---
Signif. codes:  0 "****" 0.001 "***" 0.01 "*" 0.05 "." 0.1 " " 1
# Abbreviations
# Std.Error = Standard error
# Df        = Degrees of freedom
# Sum Sq    = Sum of squares
# Mean Sq   = Mean square
# F-value   = The F-statistic of ANOVA
# Pr(>F)    = Probability level of F-value
# Signif.   = Significance

```

Direct interpretation (use) of the regression as reported in the R output is difficult. Thus, an appropriately typeset version of the equation is provided in equation C.5 using a “ternary hook” operator⁵ and is “(test) ? yes : no” or “(test) ? 1 : 0” for substitution into the equation. The ternary

⁵Search on the Internet for terms such as “ternary logic” or “ternary hook”

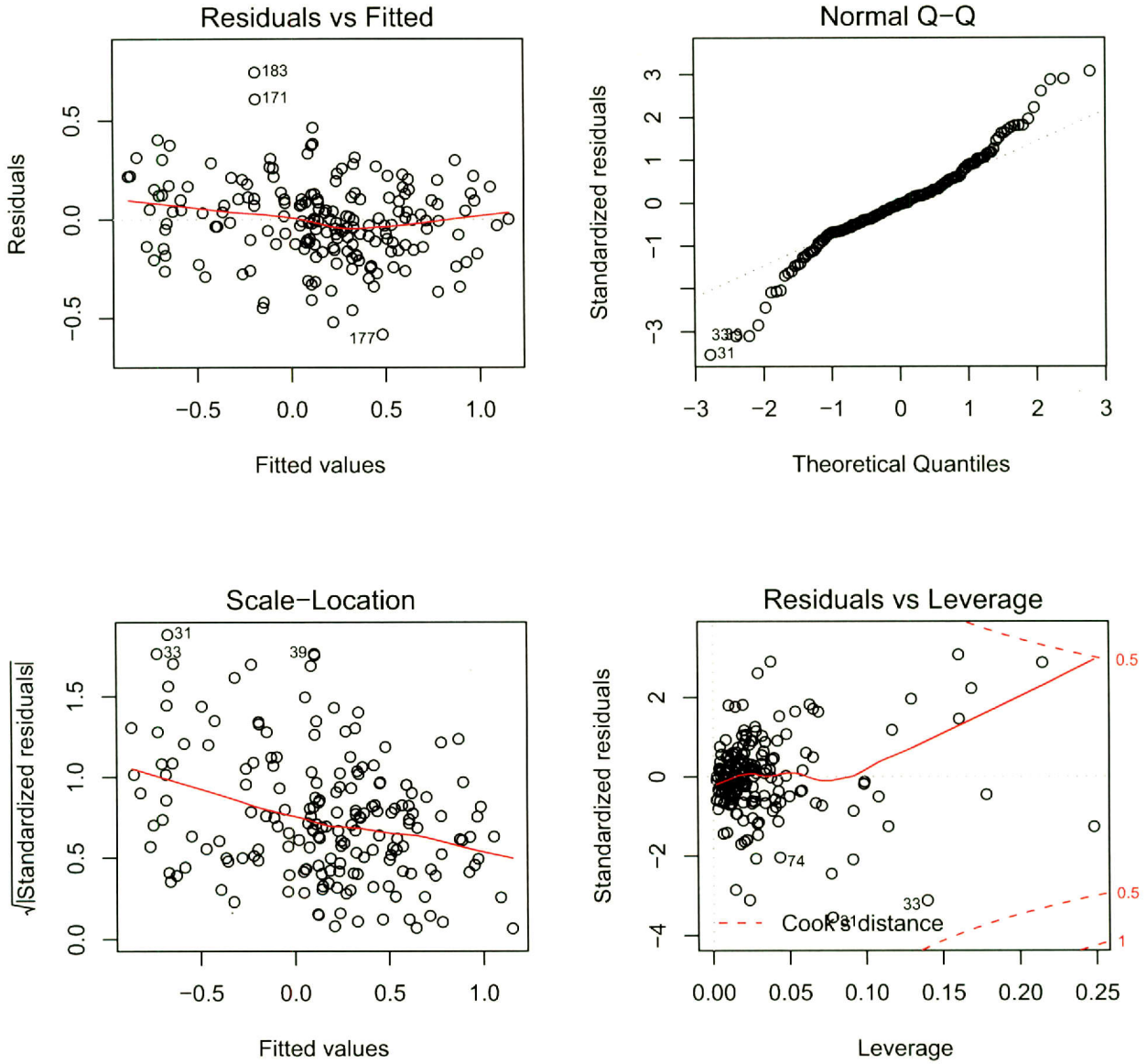

Figure C.4: Standard residual and diagnostic plots from the R environment using the `plot.lm()` function for the T_R regression equation.

hook operator provides a compact notation for an if-else test:

$$\begin{aligned} \log_{10}(T_R^{[\text{hrs}]})_{\pm 0.142} = & -1.648 + 0.542 \times \log_{10}(A^{[\text{acre}]}) - 0.042 \times BDF \\ & + 0.391 \times \langle \overline{\text{isHouston}} \rangle ? 1 : 0 \\ & + 0.326 \times \langle \overline{\text{isARS}} \rangle ? 1 : 0 \\ & + 0.270 \times \langle \overline{\log_{10}(S) \leq -2.7} \rangle ? 0 : \log_{10}(S) + 2.7 \end{aligned}$$

RSE=0.142; $R_{\text{adj}}^2=0.87$; df=185 stations (C.5)

where RSE is residual standard error in base-10 logarithms, R_{adj}^2 is adjusted R-squared (coefficient of determination), and df is the degrees of freedom of the equation. The equation shows the proper sign and magnitude of the coefficient on BDF after substitution of $\overline{BDF} = -0.0401$ multiplied by the reported coefficient of the regression. As a result, users can directly substitute the integer value of BDF into the equation. A note on use of the equation is needed—the nature of the analysis and database make the simultaneous condition of the variables $\overline{\text{isHouston}} = 1$ and $\overline{\text{isARS}} = 1$ impossible. The following list of R code represents a function that is capable of implementing eq. C.5.

```
# acre = Watershed area in acres
# slope = main-channel slope (dimensionless)
# bdf = basin-development factor
# isHouston = yes/no, true/false state variable taking on 1 or 0, respectively
# isARS = yes/no, true/false state variable taking on 1 or 0, respectively
"estTdagger4rooting" <-
function(acre, Tc=1, slope=0.01, bdf=0, isHouston=0, isARS=0) {
  broken.stickS <- log10(0.002); # break at slope = 0.002
  logSrhs <- function(x) ifelse(log10(x) <= broken.stickS,
                                0, log10(x) - broken.stickS);
  Tr <- -1.648 + 0.542*log10(acre) - 0.042*bdf +
        0.391*isHouston + 0.326*isARS + 0.270*logSrhs(slope);
  return(Tr);
}
```

The code demonstrates the numerical implementation of the ternary hook logic. If a watershed is in Houston, then `isHouston` is true (the condition `isHouston` is true), but numerically would be set to 1 when passed to the function: `estTdagger4rooting(acre, isHouston=1)` for a given watershed area in the variable `acre`. The same discussion applies to `isARS` for `isARS`.

The regression coefficients have direct interpretations as to how each variable influences T_R . To guide the reader through the phenomenological interpretations of the authors regarding equation C.5, a heavily annotated representation of the observed data and regression estimates from equation C.5 is shown in figure C.5. Discussions of the effects of select variables are now enumerated:

1. The Agricultural Research Service (ARS)-gaged watersheds or “small field-like agricultural watersheds” (**green region** in fig. C.5, the factor variable $\overline{\text{isARS}}=0$) appear to represent a fundamentally different population of watersheds than the other watersheds. The authors hypothesize that watersheds generally gaged by the ARS represent watersheds with less developed channel networks in generally crop-growing terrains with mitigation practices for soil erosion. Such watersheds would be expected to have substantially slower timing

characteristics—in fact, the data show this to be true by about 33 percent of a \log_{10} -cycle compared to the other undeveloped and non-Houston-area watersheds. The authors suggest that the design purposes of transportation infrastructure engineers are needed at stream crossings (culverts and small bridges over substantial channels) for watersheds that would generally not be classified ($\overline{\text{isARS}} = 0$) as similar to the Agricultural Research Service-gaged watersheds.

2. Houston-area and, by extension, coastal-plain watersheds in Texas, (**red region** in fig. C.5, the factor variable $\overline{\text{isHouston}}=0$) potentially show the greatest range in increase of T_R from undeveloped $BDF=0$ conditions to fully developed as represented by $BDF=12$ —the increase is approximately 80 percent of a \log_{10} -cycle. Also, the authors observe that the undeveloped Houston-area watersheds show some overlap with the Agricultural Research Service-gaged watersheds, which is consistent with the field nature and low slope of undeveloped watersheds in the region. Furthermore, the least developed watersheds in the Houston-area have slower T_R by about 40 percent of a \log_{10} -cycle.
3. The undeveloped and non-Houston-area watersheds (**blue region** in fig. C.5) have shorter T_R than the undeveloped and lower-sloped Houston-area watersheds. Furthermore, the T_R values scatter about the $\sqrt{A[\text{sqmi}]}$ line, which is consistent with a long-standing, but unreferenced, rule-of-thumb within the Texas infrastructure design community that square root of drainage area in square miles estimates a characteristic watershed time in hours.
4. The developed ($BDF>0$) and non-Houston area watersheds (**purple region** in fig. C.5) have shorter T_R than undeveloped ($BDF=0$) watersheds and is logically consistent with the expected results of watershed development, which is typically manifested by short circuiting of flow paths in the watershed by hydraulic elements such as curbs, gutters, and lined channels.
5. The coefficient on S is 0.270 and is positive, which means that for other variables being equal, T_R increases with increasing slope. **This relation is opposite of that expected based on hydraulic principles.** The cause is related strongly to the co-variation of A and S : larger watersheds are associated with smaller slopes and perhaps related to the general distribution of available watersheds for analysis. Extensive analysis could not yield a model with the desired relation with slope without contracting the range of A included in the modeling. This would result in selective choice of stations to force a model to match inherent physical constraints of watershed response to rainfall. The authors reached a stopping point because of concerns over implementing a T_R equation that yields smaller (larger) time for larger (smaller) S .

Analysis of C_R for pervious surfaces, depending upon interpretation of small BDF and watersheds in Texas (about 80), shows a central tendency of about $C_R \approx 0.15\text{--}0.20$ with a median of about 0.17. This median is important in the development of eq. 3.3.

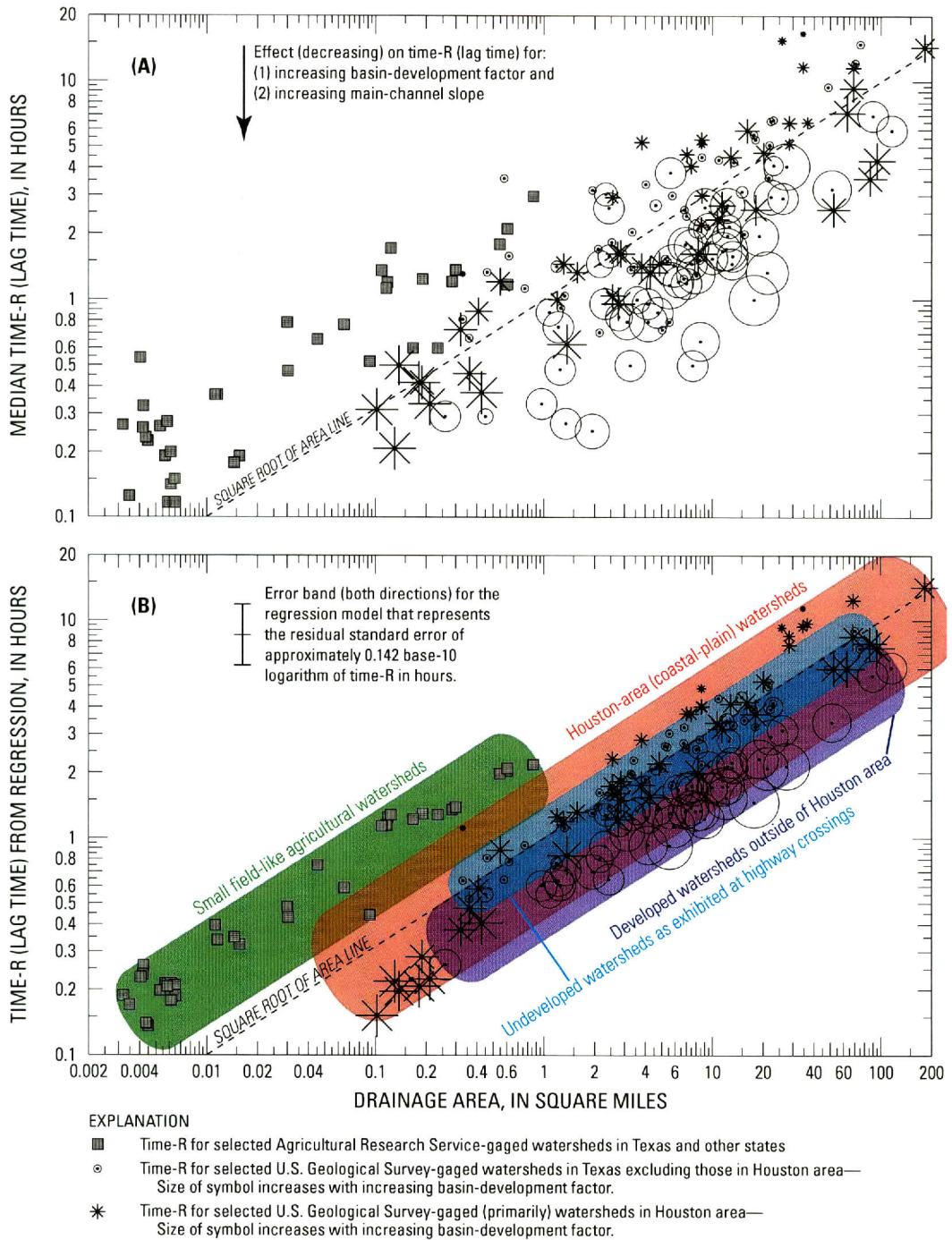

Figure C.5: Relation between Time-R and drainage area and basin-development factor by watershed type for observed (median, plot A) values and those estimated by regression (plot B).

The mean C_{tex} for watersheds throughout Texas outside of Houston, Texas area are

$$C_{\text{tex}} = \begin{cases} 0.18 & \text{for } BDF < 6 \\ 0.32 & \text{for } BDF \geq 6 \end{cases} \quad (\text{C.6})$$

The mean C_{hou} for watersheds in the Houston, Texas, area are

$$C_{\text{hou}} = \begin{cases} 0.13 & \text{for } BDF < 6 \\ 0.28 & \text{for } BDF \geq 6 \end{cases} \quad (\text{C.7})$$

The mean C_{ars} for rural and non-highway watersheds are

$$C_{\text{ars}} = 0.09 \quad \text{for } BDF = 0 \quad (\text{C.8})$$

C.1.3. Distribution of C_R and Relation between C_R and Drainage Area and Basin-Development Factor

A generalized Pareto distribution having a quantile function of $\xi + \alpha[1 - (1 - F)^\kappa]/\kappa$ for nonexceedance probability F was fit to the distribution of median C_R by station for the 185 stations. The distribution was fit by the method of L-moments and has parameters of $\xi = 0.042$, $\alpha = 0.272$, and $\kappa = 0.299$. The distribution reduces to the following quantile function

$$C_R(F) = 0.95 - 0.91(1 - F)^{0.3}, \quad (\text{C.9})$$

where $C_R(F)$ is the distribution of the C_R values for nonexceedance probability F . The limits of $C_R(F)$ are 0.04 and 0.95 for $F = 0$ and $F = 1$, respectively. Finally, the relation between C_R and A is shown in figure C.6. The figure also depicts, by varying the size of the symbols, the relative magnitude of BDF . It is seen in the figure that $C_R \approx 0.15$ is an ad hoc, but reasonable, location of central tendency for undeveloped to lightly developed watersheds (the smallest of the symbols, not including the square symbols for ARS-gaged watersheds).

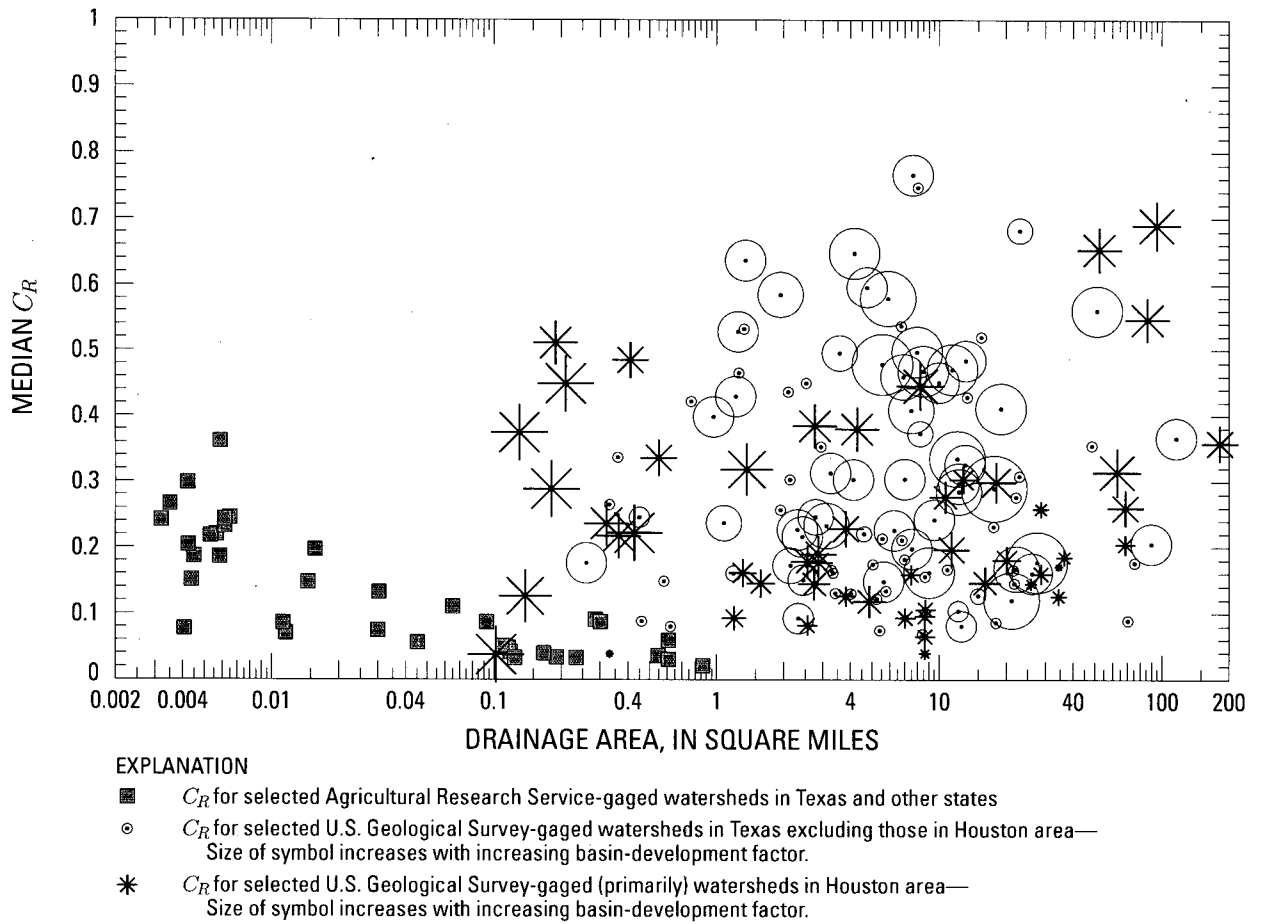

Figure C.6: Relation between C_R and drainage area and basin-development factor (BDF) by watershed type for median observed values.

C.2. Algorithms of the Unified Rational Method Appendix

This section lists fundamental algorithms written in R that were used during the development of the Unified Rational Method in Texas (URAT) as described in Section 3. These algorithms are not meant for stand-alone application and essential files documenting the depth-duration frequency of rainfall by county in Texas from Asquith and Roussel (2004) are not included in this report. The purpose of this appendix is provide a means of archival of particularly significant “units” of analysis in case the task of reviewing, reproducing, revising, and extending URAT is ever undertaken.

This listing imports a library and sets of some constants.

```
library(RTexasFFQ); # need the flood-frequency
                    # equations of Asquith and Roussel (2009)
isCrop <- 0; # watersheds are not small field-like agricultural
bdf <- 0; # basin-development factor
imp <- 0; # watershed has no impervious cover
C <- 0.15;
```

This listing is used for dynamic log-log lookup of intensity-duration frequency of rainfall for a specified duration and nonexceedance probability.

```
"IDF" <-
function(D=1, F=0.5, county="HARRIS") {
  Tcs <- c(0.25, 0.5, 1, 2, 3, 6, 12);
  ddf.env <- get(county, ddf.atlas);
  F.ddf <- get("F", envir=ddf.env); # extract list of rainfall nonexceeds
  DDF.at.F <-
    sapply(Tcs, function(x)
      return(get(as.character(x), envir=ddf.env)[F.ddf == F]));

  IDF.at.F <- DDF.at.F/Tcs;

  my.new.min <- 0.01;
  n <- length(IDF.at.F);
  idfslope <- (log10(IDF.at.F[1]) - log10(IDF.at.F[2])) /
    (log10(Tcs[1]) - log10(Tcs[2]));

  maxidf <- 10^(log10(IDF.at.F[1]) -
    idfslope*(log10(Tcs[1]) - log10(my.new.min)));

  my.new.max <- 18;
  idfslope <- (log10(IDF.at.F[n-1]) - log10(IDF.at.F[n])) /
    (log10(Tcs[n-1]) - log10(Tcs[n]));

  minidf <- 10^(log10(IDF.at.F[n]) -
    idfslope*(log10(Tcs[n]) - log10(my.new.max)));

  interpolated.Tcs <- c(my.new.min, Tcs, my.new.max);
  IDF.at.F <- c(maxidf, IDF.at.F, minidf);
  DDF.at.F <- interpolated.Tcs*IDF.at.F;

  #print(interpolated.Tcs);
```

```

#print(DDF.at.F);
#print(IDF.at.F);

my.lowess <- lowess(log10(IDF.at.F)~log10(interpolated.Tcs))

plot(interpolated.Tcs, IDF.at.F, log="xy", type="b",
      xlab="LOG TIME IN HOURS", ylim=c(0.01,50),
      ylab="LOG INTENSITY IN INCHES PER HOUR");
mtext( paste(county," AT NONEXCEEDANCE F=",F, sep="" ) );
the.IDF <- 10^approx(log10(interpolated.Tcs),
                   log10(IDF.at.F),
                   xout=log10(D), rule=2)$y;
lines(c(      D, D), c( 0.0001, the.IDF), lty=2);
lines(c(0.0001, D), c(the.IDF, the.IDF), lty=2);
lines(10^my.lowess$x, 10^my.lowess$y, col=2);
#print(DDF.at.F);
while(1) {
  #xyclick <- locator(1);
  #print(xyclick);
  ans <- identify(interpolated.Tcs, IDF.at.F, n=1, plot=FALSE);
  message("TIME=",interpolated.Tcs[ans]);
  message("IDF=",IDF.at.F[ans]);
  break;
}
return(the.IDF);
}

```

This listing provides URAT processing for specific nonexceedance probabilities.

```

"processRational" <-
function(F.needed=0.5,
        slopes=10^seq(-3, -1, by=0.5),
        areas=10^seq(1, 4, by=0.5),
        Tcs=c(0.25, 0.5, 1, 2, 3, 6, 12),
        useomegaem=TRUE, plotem=FALSE) {

  layout(matrix(1:2, nrow=2));
  # Vectors to hold computational results
  O.county <- vector(mode="numeric");
  B.county <- P.county <- A.county <- S.county <- O.county;
  for(county in COUNTIES) {
    F.regress <- T.regress <- S.regress <- A.regress <- vector(mode="numeric");
    Omega.EM <- NULL;
    map <- get(county, COUNTY_MAP);
    lat <- get(county, COUNTY_LAT);
    lon <- get(county, COUNTY_LON);

    ddf.env <- get(county, ddf.atlas); # extract DDF for the county
    F.ddf <- get("F", envir=ddf.env); # extract list of rainfall nonexceeds
    DDF.at.Fneeded <-
      sapply(Tcs, function(x)
        return(get(as.character(x), envir=ddf.env)[F.ddf == F.needed]));

    IDF.at.Fneeded <- DDF.at.Fneeded/Tcs;
  }
}

```



```

my.new.min <- 0.01;
n <- length(IDF.at.Fneeded);
idsfslope <- (log10(IDF.at.Fneeded[1]) - log10(IDF.at.Fneeded[2])) /
             (log10(Tcs[1]) - log10(Tcs[2]));

maxidf <- 10^(log10(IDF.at.Fneeded[1]) -
             idsfslope*(log10(Tcs[1]) - log10(my.new.min)));

my.new.max <- 18;
idsfslope <- (log10(IDF.at.Fneeded[n-1]) - log10(IDF.at.Fneeded[n])) /
             (log10(Tcs[n-1]) - log10(Tcs[n]));

minidf <- 10^(log10(IDF.at.Fneeded[n]) -
             idsfslope*(log10(Tcs[n]) - log10(my.new.max)));

interpolated.Tcs <- c(my.new.min, Tcs, my.new.max);
IDF.at.Fneeded <- c(maxidf, IDF.at.Fneeded, minidf);
DDF.at.Fneeded <- interpolated.Tcs*IDF.at.Fneeded;

#print(idsfslope);      print(IDF.at.Fneeded);
#print(DDF.at.Fneeded); print(interpolated.Tcs);

#print(DDF.at.Fneeded); stop();
#print(log10(IDF.at.Fneeded)); print(log10(interpolated.Tcs));
if(plotem) {
  plot(log10(c(my.new.min, my.new.max)),
       c(-1,2), type="n",
       xlab="LOG OF DURATION, IN HOURS",
       ylab="LOG OF INTENSITY, IN IPR");
  points(log10(interpolated.Tcs), log10(IDF.at.Fneeded),
         pch=c(16,1,1,1,1,1,1,1,1,1,16));
  lines(log10(interpolated.Tcs), log10(IDF.at.Fneeded));
  mtext(county);
}
for(slope in slopes) { # for each slope, process this loop
  for(area.in.acres in areas) { # for each time of concentration, process
    this loop
    op <- options(warn=-1); # suppress warnings
    AR <- asquith2009a(area=area.in.acres/640, precip=map,
                     slope=slope, latitude=lat, longitude=lon,
                     verbose=FALSE, plotem=FALSE);
    options(op); # restore warnings

    F.values <- AR$NonexceedanceProb; # extract list of nonexceeds
    ifelse(useomegaem, QT.by.regression <- AR$Q.OmegaEM,
          QT.by.regression <- AR$Q.noOmegaEM);
    Omega.EM <- AR$OmegaEM;

    QTeq <- sapply(F.ddf, function(x)
                  return(QT.by.regression[F.values == x]));
    QTeq <- sapply(F.needed, function(x)
                  return(QTeq[F.ddf == x]));

    A <- area.in.acres; # relabel the area in acres

```

```

the.I <- QTeq/(1.008*C*A); # intensity of equivalence

# linearly interpolate in log-log the required time
# This is the time of equivalence
the.T <- approx(log10(IDF.at.Fneeded),
               log10(interpolated.Tcs),
               xout=log10(the.I), rule=2)$y;
if(plotem) lines(c(the.T,the.T), c(-2,2), col=2)
F.regress <- c(F.regress, F.needed);
T.regress <- c(T.regress, the.T);
S.regress <- c(S.regress, rep(slope, length(F.needed)));
A.regress <- c(A.regress, rep(area.in.acres, length(F.needed)));
}
}
T.regress <- 10^T.regress; # yes, we'll turn around and log it.
T.LM <- lm(log10(T.regress)~log10(A.regress)+log10(S.regress));
print(county);
#print(summary(T.LM));
if(plotem) {
  plot(c(log(my.new.min),log(my.new.max)), c(-3,3), type="n",
        xlab="LOG DURATION, IN HOURS",
        ylab="LOG FITTED DURATION, IN HOURS");
  points(log10(T.regress), fitted.values(T.LM), cex=abs(log10(S.regress)));
  abline(0,1);
  #readline();
}
S <- T.LM$coefficients[3];
A <- T.LM$coefficients[2];
B <- T.LM$coefficients[1];
O.county <- c(O.county, Omega.EM);
P.county <- c(P.county, map);
B.county <- c(B.county, B);
A.county <- c(A.county, A);
S.county <- c(S.county, S);
}
print(summary(B.county));
print(summary(A.county));
print(summary(S.county));
return(list(B=B.county, A=A.county, S=S.county,
           O=O.county, P=P.county));
}

```

This listing processes each nonexceedance probability of the URAT in parallel.

```

rat2yr <- processRational(F.needed=0.50, plotem=TRUE);
rat5yr <- processRational(F.needed=0.80, plotem=TRUE);
rat10yr <- processRational(F.needed=0.90, plotem=TRUE);
rat25yr <- processRational(F.needed=0.96, plotem=TRUE);
rat50yr <- processRational(F.needed=0.98, plotem=TRUE);
rat100yr <- processRational(F.needed=0.99, plotem=TRUE);

```

This listing constructs the URAT regression coefficient tables 3.2-3.1.

```

COUNTY.B <- data.frame(COUNTY = sapply(COUNTIES, function(x)
    return(get(x, COUNTY_NAMES))),
    B2yr = sprintf("%0.3f", 60*10^rat2yr$B),
    B5yr = sprintf("%0.3f", 60*10^rat5yr$B),
    B10yr = sprintf("%0.3f", 60*10^rat10yr$B),
    B25yr = sprintf("%0.3f", 60*10^rat25yr$B),
    B50yr = sprintf("%0.3f", 60*10^rat50yr$B),
    B100yr = sprintf("%0.3f", 60*10^rat100yr$B));
COUNTY.A <- data.frame(COUNTY = sapply(COUNTIES, function(x)
    return(get(x, COUNTY_NAMES))),
    A2yr = sprintf("%0.3f", rat2yr$A),
    A5yr = sprintf("%0.3f", rat5yr$A),
    A10yr = sprintf("%0.3f", rat10yr$A),
    A25yr = sprintf("%0.3f", rat25yr$A),
    A50yr = sprintf("%0.3f", rat50yr$A),
    A100yr = sprintf("%0.3f", rat100yr$A));
COUNTY.S <- data.frame(COUNTY = sapply(COUNTIES, function(x)
    return(get(x, COUNTY_NAMES))),
    S2yr = sprintf("%0.3f", -rat2yr$S),
    S5yr = sprintf("%0.3f", -rat5yr$S),
    S10yr = sprintf("%0.3f", -rat10yr$S),
    S25yr = sprintf("%0.3f", -rat25yr$S),
    S50yr = sprintf("%0.3f", -rat50yr$S),
    S100yr = sprintf("%0.3f", -rat100yr$S));

write.table(COUNTY.B, "countywide_Bvalues.tex", sep=" & ",
    eol=" \\tabularnewline\n", quote=FALSE, row.names=FALSE);
write.table(COUNTY.A, "countywide_Avalues.tex", sep=" & ",
    eol=" \\tabularnewline\n", quote=FALSE, row.names=FALSE);
write.table(COUNTY.S, "countywide_Svalues.tex", sep=" & ",
    eol=" \\tabularnewline\n", quote=FALSE, row.names=FALSE);

COUNTY.B <- as.list(COUNTY.B); COUNTY.B$COUNTYKEY <- COUNTIES;
COUNTY.B <- as.data.frame(COUNTY.B);

COUNTY.A <- as.list(COUNTY.A); COUNTY.A$COUNTYKEY <- COUNTIES;
COUNTY.A <- as.data.frame(COUNTY.A);

COUNTY.A <- as.list(COUNTY.A); COUNTY.A$COUNTYKEY <- COUNTIES;
COUNTY.A <- as.data.frame(COUNTY.A);

write.table(COUNTY.B, "countywide_Bvalues.txt",
    quote=FALSE, row.names=FALSE);
write.table(COUNTY.A, "countywide_Avalues.txt",
    quote=FALSE, row.names=FALSE);
write.table(COUNTY.S, "countywide_Svalues.txt",
    quote=FALSE, row.names=FALSE);

x <- data.frame(COUNTY1 = sapply(COUNTIES[1:(254/2)], function(x)
    return(get(x, COUNTY_NAMES))),
    MAP1 = round(rat2yr$P[1:(254/2)], digits=1),
    OMEGAEM1 = round(rat2yr$O[1:(254/2)], digits=3),
    COUNTY2 = sapply(COUNTIES[(254/2+1):254], function(x)

```

```

                                return(get(x, COUNTY_NAMES))),
      MAP2      = round(rat2yr$P[(254/2+1):254], digits=1),
      OMEGAEM2 = round(rat2yr$O[(254/2+1):254], digits=3));
write.table(x, "mapomegaem_countywide_values.tex", sep=" & ",
           eol=" \\tabularnewline\n", quote=FALSE, row.names=FALSE);
x <- as.list(x); x$COUNTYKEY <- COUNTIES;
write.table(as.data.frame(x), "mapomegaem_countywide_values.txt",
           quote=FALSE, row.names=FALSE);

```

The following ensembles provided for visual summary of the regression coefficients to generalized the URAT for Texas of eq. 3.7 as shown in Section 3.

```

summary(60*10^rat2yr$B)
summary(60*10^rat5yr$B)
summary(60*10^rat10yr$B)
summary(60*10^rat25yr$B)
summary(60*10^rat50yr$B)
summary(60*10^rat100yr$B)

summary(rat2yr$A)
summary(rat5yr$A)
summary(rat10yr$A)
summary(rat25yr$A)
summary(rat50yr$A)
summary(rat100yr$A)

summary(rat2yr$S)
summary(rat5yr$S)
summary(rat10yr$S)
summary(rat25yr$S)
summary(rat50yr$S)
summary(rat100yr$S)

```

This listing creates figure 3.1.

```

x <- sapply(COUNTIES, function(x) return(get(x, COUNTY_LON)))
y <- sapply(COUNTIES, function(x) return(get(x, COUNTY_LAT)))

tmp2yr <- rat2yr$B;
tmp5yr <- rat5yr$B;
tmp10yr <- rat10yr$B;
tmp25yr <- rat25yr$B;
tmp50yr <- rat50yr$B;
tmp100yr <- rat100yr$B;

mycol2 <- 10^tmp2yr;
mycol2 <- (mycol2 - min(mycol2) + 0.01) / (max(mycol2) - min(mycol2) + 0.01)
mycol5 <- 10^tmp5yr;
mycol5 <- (mycol5 - min(mycol5) + 0.01) / (max(mycol5) - min(mycol5) + 0.01)
mycol10 <- 10^tmp10yr;
mycol10 <- (mycol10 - min(mycol10) + 0.01) / (max(mycol10) - min(mycol10) + 0.01)
mycol25 <- 10^tmp25yr;

```

```

mycol25 <- (mycol25 - min(mycol25) + 0.01) / (max(mycol25) - min(mycol25) + 0.01)
mycol50 <- 10^tmp50yr;
mycol50 <- (mycol50 - min(mycol50) + 0.01) / (max(mycol50) - min(mycol50) + 0.01)
mycol100 <- 10^tmp100yr;
mycol100 <- (mycol100 - min(mycol100) + 0.01) / (max(mycol100) - min(mycol100) +
0.01)

pdf("scalefactorB.pdf");
layout(matrix(1:6, ncol=2))
plot(x, y, col=rgb(1-mycol2, 0, 0, 0.5), pch=16,
      xlab="LONGITUDE, IN DEGRESS",
      ylab="LATITUDE, IN DEGRESS", cex=1+2*mycol2);
mtext("2-year recurrence interval");
plot(x, y, col=rgb(1-mycol5, 0, 0, 0.5), pch=16,
      xlab="LONGITUDE, IN DEGRESS",
      ylab="LATITUDE, IN DEGRESS", cex=1+2*mycol5);
mtext("5-year recurrence interval");
plot(x, y, col=rgb(1-mycol10, 0, 0, 0.5), pch=16,
      xlab="LONGITUDE, IN DEGRESS",
      ylab="LATITUDE, IN DEGRESS", cex=1+2*mycol10);
mtext("10-year recurrence interval");
plot(x, y, col=rgb(1-mycol25, 0, 0, 0.5), pch=16,
      xlab="LONGITUDE, IN DEGRESS",
      ylab="LATITUDE, IN DEGRESS", cex=1+2*mycol25);
mtext("25-year recurrence interval");
plot(x, y, col=rgb(1-mycol50, 0, 0, 0.5), pch=16,
      xlab="LONGITUDE, IN DEGRESS",
      ylab="LATITUDE, IN DEGRESS", cex=1+2*mycol50);
mtext("50-year recurrence interval");
plot(x, y, col=rgb(1-mycol100, 0, 0, 0.5), pch=16,
      xlab="LONGITUDE, IN DEGRESS",
      ylab="LATITUDE, IN DEGRESS", cex=1+2*mycol100);
mtext("100-year recurrence interval");
dev.off();

```

This listing creates figure 3.2.

```

x <- sapply(COUNTIES, function(x) return(get(x, COUNTY_LON)))
y <- sapply(COUNTIES, function(x) return(get(x, COUNTY_LAT)))

tmp2yr <- rat2yr$$;
tmp5yr <- rat5yr$$;
tmp10yr <- rat10yr$$;
tmp25yr <- rat25yr$$;
tmp50yr <- rat50yr$$;
tmp100yr <- rat100yr$$;

mycol2 <- tmp2yr;
mycol2 <- (mycol2 - min(mycol2) + 0.01) / (max(mycol2) - min(mycol2) + 0.01)
mycol5 <- tmp5yr;
mycol5 <- (mycol5 - min(mycol5) + 0.01) / (max(mycol5) - min(mycol5) + 0.01)
mycol10 <- tmp10yr;
mycol10 <- (mycol10 - min(mycol10) + 0.01) / (max(mycol10) - min(mycol10) + 0.01)

```

```

mycol25 <- tmp25yr;
mycol25 <- (mycol25 - min(mycol25) + 0.01) / (max(mycol25) - min(mycol25) + 0.01)
mycol50 <- tmp50yr;
mycol50 <- (mycol50 - min(mycol50) + 0.01) / (max(mycol50) - min(mycol50) + 0.01)
mycol100 <- tmp100yr;
mycol100 <- (mycol100 - min(mycol100) + 0.01) / (max(mycol100) - min(mycol100) +
0.01)

pdf("scalefactorS.pdf");
layout(matrix(1:6, ncol=2))
plot(x, y, col=rgb(1-mycol2, 0, 0, 0.5), pch=16,
      xlab="LONGITUDE, IN DEGRESS",
      ylab="LATITUDE, IN DEGRESS", cex=1+2*mycol2);
mtext("2-year recurrence interval");
plot(x, y, col=rgb(1-mycol5, 0, 0, 0.5), pch=16,
      xlab="LONGITUDE, IN DEGRESS",
      ylab="LATITUDE, IN DEGRESS", cex=1+2*mycol5);
mtext("5-year recurrence interval");
plot(x, y, col=rgb(1-mycol10, 0, 0, 0.5), pch=16,
      xlab="LONGITUDE, IN DEGRESS",
      ylab="LATITUDE, IN DEGRESS", cex=1+2*mycol10);
mtext("10-year recurrence interval");
plot(x, y, col=rgb(1-mycol25, 0, 0, 0.5), pch=16,
      xlab="LONGITUDE, IN DEGRESS",
      ylab="LATITUDE, IN DEGRESS", cex=1+2*mycol25);
mtext("25-year recurrence interval");
plot(x, y, col=rgb(1-mycol50, 0, 0, 0.5), pch=16,
      xlab="LONGITUDE, IN DEGRESS",
      ylab="LATITUDE, IN DEGRESS", cex=1+2*mycol50);
mtext("50-year recurrence interval");
plot(x, y, col=rgb(1-mycol100, 0, 0, 0.5), pch=16,
      xlab="LONGITUDE, IN DEGRESS",
      ylab="LATITUDE, IN DEGRESS", cex=1+2*mycol100);
mtext("100-year recurrence interval");
dev.off();

```

This listing creates figure 3.3.

```

x <- sapply(COUNTIES, function(x) return(get(x, COUNTY_LON)))
y <- sapply(COUNTIES, function(x) return(get(x, COUNTY_LAT)))

mycol2 <- 10^rat2yrnoem$B;
mycol2 <- (mycol2 - min(mycol2) + 0.01) / (max(mycol2) - min(mycol2) + 0.01)
mycol5 <- 10^rat5yrnoem$B;
mycol5 <- (mycol5 - min(mycol5) + 0.01) / (max(mycol5) - min(mycol5) + 0.01)
mycol10 <- 10^rat10yrnoem$B;
mycol10 <- (mycol10 - min(mycol10) + 0.01) / (max(mycol10) - min(mycol10) + 0.01)
mycol25 <- 10^rat25yrnoem$B;
mycol25 <- (mycol25 - min(mycol25) + 0.01) / (max(mycol25) - min(mycol25) + 0.01)
mycol50 <- 10^rat50yrnoem$B;
mycol50 <- (mycol50 - min(mycol50) + 0.01) / (max(mycol50) - min(mycol50) + 0.01)
mycol100 <- 10^rat100yrnoem$B;
mycol100 <- (mycol100 - min(mycol100) + 0.01) / (max(mycol100) - min(mycol100) +
0.01)

```

```

pdf("scalefactor_noem.pdf");
layout(matrix(1:6, ncol=2))
plot(x, y, col=rgb(1-mycol2, 0, 0, 0.5), pch=16,
      xlab="LONGITUDE, IN DEGRESS",
      ylab="LATITUDE, IN DEGRESS", cex=1+2*mycol2);
mtext("2-year recurrence interval");
plot(x, y, col=rgb(1-mycol5, 0, 0, 0.5), pch=16,
      xlab="LONGITUDE, IN DEGRESS",
      ylab="LATITUDE, IN DEGRESS", cex=1+2*mycol5);
mtext("5-year recurrence interval");
plot(x, y, col=rgb(1-mycol10, 0, 0, 0.5), pch=16,
      xlab="LONGITUDE, IN DEGRESS",
      ylab="LATITUDE, IN DEGRESS", cex=1+2*mycol10);
mtext("10-year recurrence interval");
plot(x, y, col=rgb(1-mycol25, 0, 0, 0.5), pch=16,
      xlab="LONGITUDE, IN DEGRESS",
      ylab="LATITUDE, IN DEGRESS", cex=1+2*mycol25);
mtext("25-year recurrence interval");
plot(x, y, col=rgb(1-mycol50, 0, 0, 0.5), pch=16,
      xlab="LONGITUDE, IN DEGRESS",
      ylab="LATITUDE, IN DEGRESS", cex=1+2*mycol50);
mtext("50-year recurrence interval");
plot(x, y, col=rgb(1-mycol100, 0, 0, 0.5), pch=16,
      xlab="LONGITUDE, IN DEGRESS",
      ylab="LATITUDE, IN DEGRESS", cex=1+2*mycol100);
mtext("100-year recurrence interval");
dev.off();

```

D. MODIFIED RATIONAL METHOD

The purpose of this appendix is to present development and results from analysis of the modified rational method. The modified rational method is an extension of the rational method for those cases where a hydrograph is required and not simply an estimate of the peak discharge. This situation arises during design of small detention facilities and other settings that require a hydrograph, but where application of the unit hydrograph method is not warranted.

D.1. Modified Rational Method for Texas Watersheds

The modified rational method (MRM) is a unit hydrograph method with simplified trapezoidal unit hydrograph shown in Figure 2.5. The MRM unit hydrograph with duration of D hrs (Figure 2.5) results from a uniform excess (net) rainfall intensity of $1/D$ in/hr over D hrs, and it has a peak discharge of A/T_c cfs for a drainage area A in acres and T_c in hours. T_c is the time of concentration of the watershed. The application of the MRM involves two steps: (1) determination of rainfall loss using rational method concept, that is, using rational runoff coefficient, and (2) determination the MRM unit hydrograph using T_c as the input parameter, in addition to applying the procedure of unit hydrograph convolution. In this appendix, results from application of the MRM to selected Texas watersheds is reported. The objectives were to evaluate (1) the applicability of the method if blindly applied to Texas watersheds with drainage greater than the standard 200-acre limit, (2) to study the effects of a forward-specified runoff coefficient (C_{lit}) and back-computed runoff coefficients (C_{vbc}) on the prediction of runoff hydrograph using MRM, and (3) to compare MRM with other unit hydrograph methods on prediction of peak discharges.

D.2. Runoff Coefficients and Time of Concentration

The watershed dataset was taken from a larger dataset accumulated by researchers and used in a series of research projects funded by TxDOT (Asquith and others, 2004). The dataset comprised 90 USGS streamflow-gaging stations located in the central part of Texas. The drainage area of study watersheds ranged from approximately 0.8–440.3 km² (0.3–170 mi²). Of this dataset, the drainage area of 80 watersheds is less than 65 km² (25 mi²). The rainfall-runoff dataset was comprised of about 1,600 rainfall-runoff events recorded during the period from 1959–1986. The number of events available for each watershed varied: for some watersheds only a few events were available whereas for some others as many as 50 events were available.

Time of concentration is a required parameter of the MRM unit hydrograph. It was estimated using two methods: (1) the combination of the Kerby (1959) equation and the Kirpich (1940) method and (2) the square root of watershed drainage area. The first method was recommended by researchers to TxDOT for estimating time of concentration in Texas watersheds through the project 0–4796 (Roussel and others, 2005). T_c values for the 90 watersheds were estimated using the Kerby-Kirpich method by three research groups: LU (Lamar University), UH (University of Houston), and USGS, and were developed for TxDOT project 0–4696. For the second method, T_c values in hours were estimated as the square root of watershed drainage area in square miles. This is an *ad hoc* method and considered to be an engineering rule-of-thumb, which can be used to check other methods (Fang and others, 2007). T_c estimated as the square root of drainage area passes through the generalized center of the data values of T_c derived from observed rainfall-runoff data analysis (Roussel and others, 2005; Fang and others, 2007).

The rainfall loss determination was accomplished using the volumetric interpretation of the rational runoff coefficient. The precise definition and subsequent interpretation of C varies. The C of a watershed can be defined either as the ratio of total depth of runoff to total depth of rainfall or as the ratio of peak rate of runoff to rainfall intensity for the time of concentration (Wanielista and Yousef, 1993). Figure 2.1 (Wanielista and others, 1997b, from) shows that rainfall loss for a uniform rainfall input (intensity of i) is equal to $(1 - C)iDA$ (D is rainfall duration and A is drainage area) and rainfall excess is equal to $CiDA$. The rational rainfall loss method is the constant fractional loss model; it assumes that the watershed immediately converts a constant fraction (proportion) of each rainfall input into an excess rainfall fraction that subsequently contributes to runoff (McCuen, 1998). This method was successfully implemented by University of Houston researchers for TxDOT projects 0–4193 and 0–4194, and the rainfall loss fraction were optimized using observed rainfall and runoff events.

Two runoff coefficients were examined for the application of the modified rational method. The first is a watershed composite literature-based coefficient (C_v^{lit}), derived using the land-use information for the watershed and published C_v^{lit} values for various land-uses. The numerical values assigned to different land use categories are listed in Table D.1; it includes sources and references for the selected C values. The composite C value assigned to a watershed is the area-weighted mean value of individual grid-cell values, using,

$$C_v^{\text{lit}} = \frac{\sum_{i=1}^n C_i A_i}{\sum_{i=1}^n A_i}, \quad (\text{D.1})$$

where $i = i^{\text{th}}$ sub-area with a particular land-use type, n is the number of land-use classes in the watershed, C_i is the literature-based runoff coefficient for the i^{th} land-use class, and A_i is the area of the i^{th} land-use class in the watershed. This runoff coefficient will not necessarily preserve observed runoff volumes from observed rainfall.

The second runoff coefficient is a back-computed volumetric runoff coefficient, C_v^{bc} , determined by preserving the runoff volume and using observed rainfall and runoff data. C_v^{bc} is estimated by the ratio of total runoff depth to total rainfall depth for individual observed storm events. The determination and comparison of C_v^{lit} and C_v^{bc} are presented elsewhere (Dhakal and others, 2010).

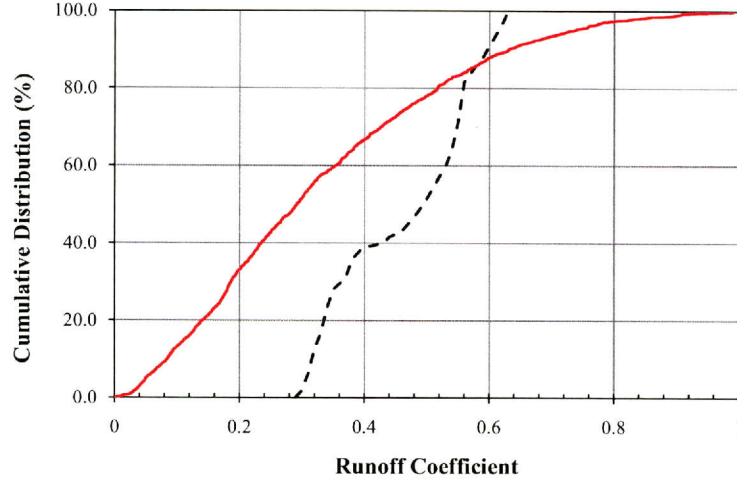

Figure D.1: Cumulative distributions of the runoff coefficients C_v^{bc} (red) and C_v^{lit} (black).

The cumulative frequency distributions of C_v^{lit} and C_v^{bc} developed for the study are shown on Figure D.1. The black curve is the distribution of C_v^{lit} values. Of particular interest is that the distribution of C_v^{lit} is limited, ranging from 0.3–0.7. The distribution of C_v^{bc} values is depicted by the red curve. Values of C_v^{bc} comprise the theoretical domain of 0.0–1.0. The median value for C_v^{lit} is 0.49; the median value of C_v^{bc} is 0.29. If it can be assumed that C_v^{bc} values are representative of actual watershed behavior, then values of C_v^{lit} from the literature are about two times greater than they should be.

D.3. Estimated Runoff Hydrographs Using the MRM

To predict or estimate the direct runoff hydrographs for a particular rainfall-runoff event using unit hydrograph convolution, the unit hydrograph (UH) needs to be developed for each watershed. In this study, observed rainfall hyetograph and runoff hydrograph data were organized using a time interval of 5 minutes. The modified rational method was used to develop the 5-minute trapezoidal unit hydrograph. For all watersheds used in the study, the rainfall duration or unit hydrograph duration (5 minutes) is less than the time of concentration. The peak discharge (Q_p) of the UH is estimated by

$$Q_p = \frac{A}{T_c} \quad (D.2)$$

The time interval used for unit hydrograph convolution was 5 minutes. Ordinates from the predicted and observed discharge hydrographs were reported and compared using the same 5-minute time interval. Once the unit hydrograph is obtained, the excess rainfall or the net rainfall is obtained from the product of the incremental rainfall and C . Finally the lagging method or convolution of the unit hydrographs with the rainfall excess was applied to obtain the direct runoff hydrograph for

Table D.1: Runoff coefficients used in the modified rational method. [NLCD = NLCD Classification Grid Code; DESC = Description from 2001 NLCD website; C^{GIS} = Runoff coefficient used in GIS analysis; C_{std} = representative literature ranges used to develop C^{GIS} values; SOURCE = source document for specific land use value.]

| NLCD | DESC | C^{GIS} | C_{std} | SOURCE |
|------|-----------------------------|-----------|-----------|--|
| 11 | Open Water | 1.00 | – | – |
| 21 | Developed, Open Space | 0.40 | 0.30–0.50 | ASCE (1992) |
| 22 | Developed, Low Intensity | 0.55 | 0.55 | Schwab and Frevert (1993) |
| 23 | Developed, Medium Intensity | 0.65 | 0.65 | Schwab and Frevert (1993) |
| 24 | Developed, High Intensity | 0.83 | 0.70–0.95 | Texas Department of Transportation (2009) |
| 31 | Barren Land | 0.65 | 0.50–0.80 | Schwab and Frevert (1993) |
| 41 | Deciduous Forest | 0.52 | 0.52 | Mulholland PJ (1990) |
| 42 | Evergreen Forest | 0.48 | 0.28–0.68 | Law (1956); American Society of Civil Engineers (1996) |
| 43 | Mixed Forest | 0.48 | 0.28–0.68 | Law (1956); American Society of Civil Engineers (1996) |
| 52 | Shrub/Scrub | 0.30 | 0.10–0.40 | Leopold and Dunne (1978) |
| 71 | Grassland/Herbaceous | 0.22 | 0.10–0.30 | Schwab and Frevert (1993) |
| 81 | Pasture/Hay | 0.35 | 0.15–0.45 | Leopold and Dunne (1978) |
| 82 | Cultivated Crops | 0.40 | 0.20–0.50 | Leopold and Dunne (1978) |
| 90 | Woody Wetlands | 1.00 | – | – |
| 95 | Emergent Herbaceous Wetland | 1.00 | – | – |

each storm event. Different combinations of C and T_c were tested to get different simulated results of the direct runoff hydrographs to check the sensitivity of the results to the timing parameters and the runoff coefficients.

Figure D.2 is a plot of the observed and computed peak discharges using back-computed runoff coefficient (C_v^{bc}) and four different timing parameters. It is observed that all the results overlap each other and there is not much change in the results for the change in time of concentration method. Use of C_v^{bc} results in preservation of event runoff volume. Ideally, computed and observed peaks should plot precisely along the equal value line (red line in Figure D.2). However, the unit hydrograph is a mathematical model that is an incomplete description of the complexity of the combination of the rainfall-runoff process and runoff dynamics. Therefore, the relatively simple approach cannot capture the nuances of watershed dynamics, there are deviations from this ideal (the equal-value line).

Figure D.3 is a plot of the observed and computed time to peak (T_p) using back-computed runoff

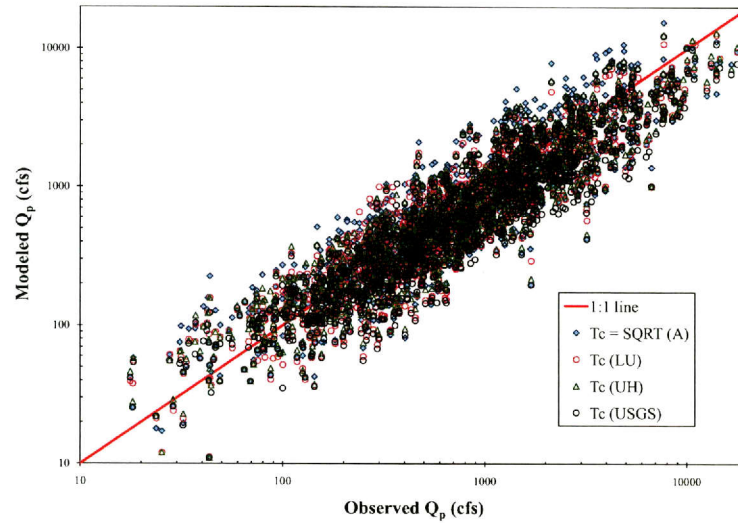

Figure D.2: Modeled and observed peak discharge from C_v^{bc} and different timing parameters.

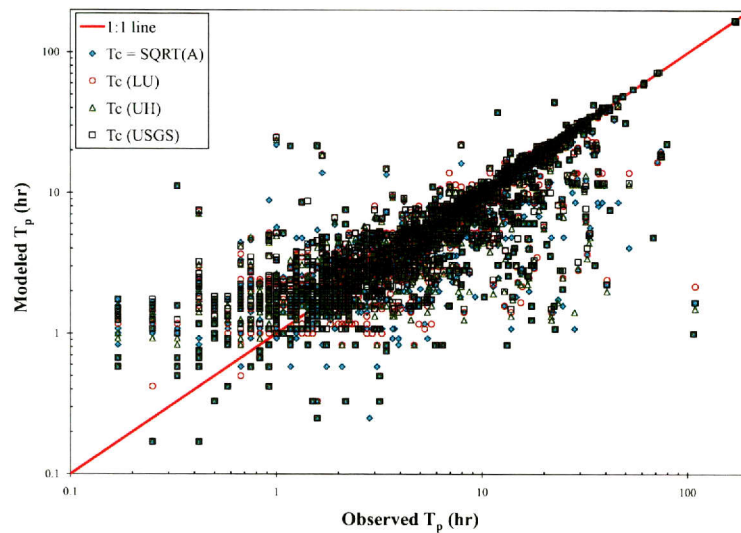

Figure D.3: Modeled and observed time to peak for C_v^{bc} and different timing parameters.

coefficient (C_v^{bc}) and four different timing parameters. It is observed that most of the data are along the equal value line.

Figure D.4 is similar to Figure D.2, constructed using observed and computed peak discharges based on C_v^{lit} and various timing parameters. It is observed that most of the values in this case is above the equal value line. A conclusion, based on these observations, is that the use of literature based values (C_v^{lit}), applied in a reasonably systematic fashion, will tend to generate estimates of peak discharge that exceed expected values (observations) when the values are interpreted as volumetric

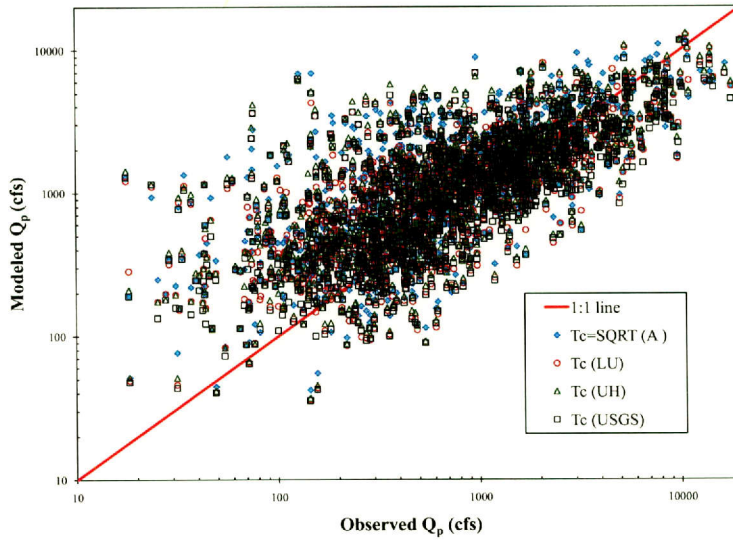

Figure D.4: Modeled and observed time to peak for C_v^{lit} and different timing parameters.

coefficients. Furthermore, literature-based estimates (C_v^{lit}) of the runoff coefficient yield results that do not preserve runoff volume when applied to measured rainfall-runoff events.

Figure D.5 is a plot of the observed and computed peak discharges using back-computed (C_v^{bc}) and forward-computed runoff coefficients (C_v^{lit}) when T_c values estimated using the Kerby-Kirpich method with estimates derived by USGS researchers. Visual inspection suggests about one-third of the black markers are quite far from the green-marker cloud. Figure D.6 is a plot of the time to peak using back-computed (C_v^{bc}) and forward-computed runoff coefficients (C_v^{lit}). There is not any difference between the times to peak using two different runoff coefficients, and this is because T_p is controlled by input of T_c and the same T_c values were used. Hence the simulation results of peak discharge are more sensitive to the choice of the runoff coefficients and the time to peak results are not.

A useful examination of errors (in this application, deviations between observed and predicted peak discharges) is the cumulative distribution of sorted deviations between the estimates of peak discharge and the equal-value line (vertical distance between the markers and the equal value line). The distribution of such errors provides insight into the magnitude and dispersion of errors in predictions constructed using the approaches discussed in the previous paragraphs of this report. If the model reproduces observed peak discharges reasonably well, then a median value of zero and a step distribution is expected. These conditions indicate that the model is reproducing the observed peak discharge (on the average) and that errors between predicted and observed peak discharges are small (as measured by the variance between predicted and observed peak discharges).

Such a plot is depicted on Figure D.7 for the two runoff coefficients (C_v^{bc} and C_v^{lit}) and the two estimates timing parameter used for this study (Kerby-Kirpich and square root of drainage area Fang and others, 2007). The theoretical best shape of this plot would be a step function centered at

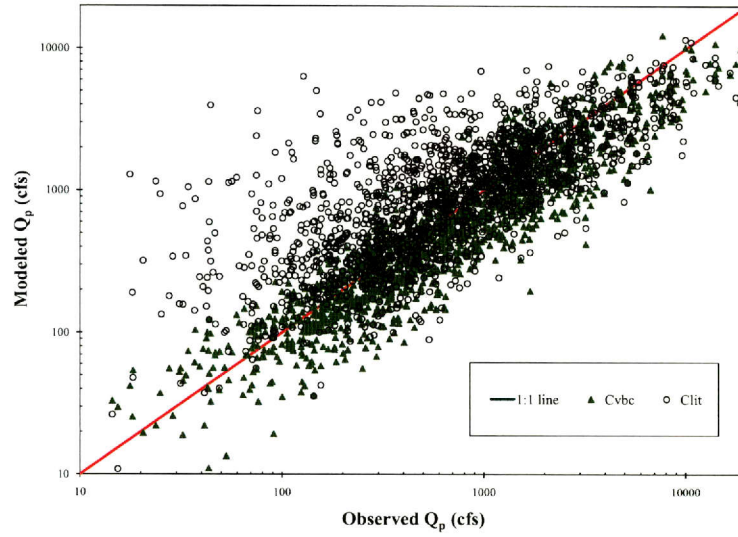

Figure D.5: Modeled and observed peak discharge from C_v^{bc} (green) and C_v^{lit} (black) with timing parameters derived from the Kerby-Kirpich method.

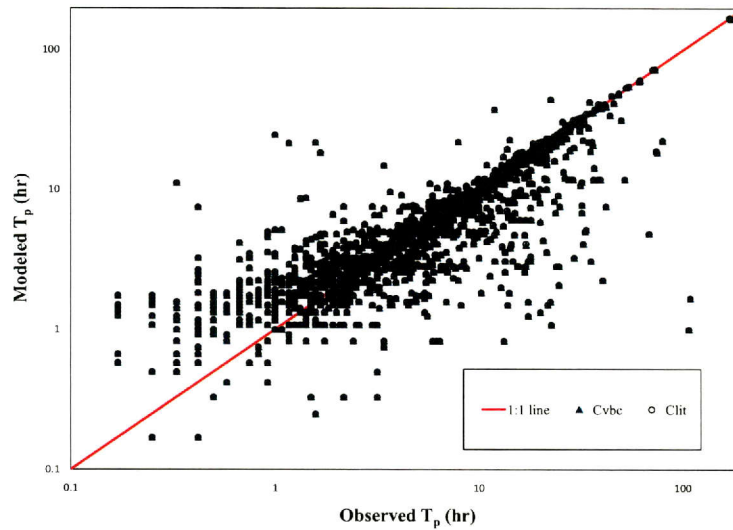

Figure D.6: Modeled and observed time to peak from C_v^{bc} (blue) and C_v^{lit} (black) with timing parameters from the Kerby-Kirpich method.

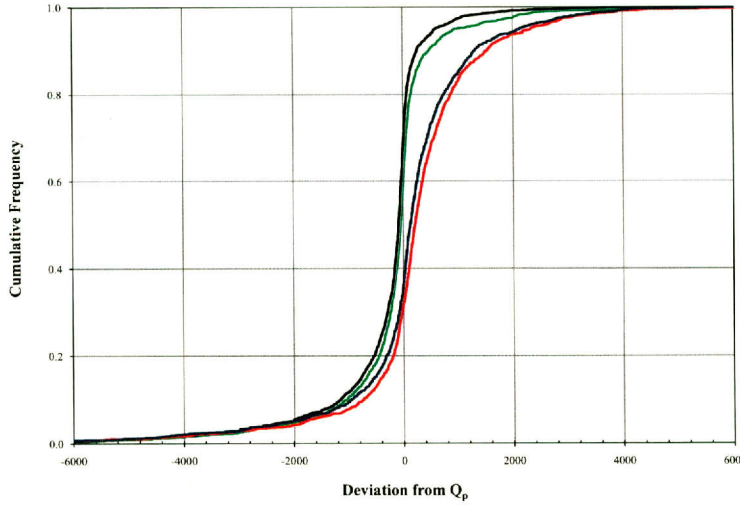

Figure D.7: Cumulative distribution of deviations (modeled Q_p - observed Q_p) from $Q_{p, \text{obs}}$ for $Q_{p, \text{bc}}$ using Kerby-Kirpich and C_{vbc} (black curve), $Q_{p, \text{lit}}$ using Kerby-Kirpich and C_{lit} (blue curve), $Q_{p, \text{bc}}$ using square-root-area and $C_{v, \text{bc}}$ (green curve) and $Q_{p, \text{lit}}$ using square root of the drainage area and C_{lit} (red curve).

zero on the horizontal axis. Any other shape would occur if errors were present in the modeling results. The green and black curves represent deviations derived from back-computed runoff coefficients (C_v^{bc}). The red and blue curves represent deviations derived from forward-computed runoff coefficients (C_v^{lit}). Although the green and black curves are not a step function, nearly 40 percent of the deviations are approximately zero. In contrast, almost none of the deviations from the literature-based runoff coefficients are zero.

D.4. Comparison of MRM Results and Other Unit Hydrograph Methods

In addition to application of the MRM for 90 Texas watersheds, two other unit hydrograph models — unit hydrograph developed from the HEC1 generalized basin approach and the gamma unit hydrograph for Texas watersheds — were also used to develop the direct runoff hydrograph for each rainfall-runoff event in the 90 Texas watersheds. The objective was to compare MRM with these unit hydrograph methods. Gamma UH used in this study was developed by researchers at Lamar University for TxDOT project 0-4193 “Regional Characteristics of Unit Hydrographs.” Linear programming was used to develop unit hydrographs from observed rainfall hyetographs and runoff hydrographs, and Gamma UH was fitted to each derived unit hydrograph. Regression equations were developed for 5-minute Gamma UH parameters: peak discharge Q_p (in cfs) and time to peak T_p (in hours) (Fang and others, 2007),

$$T_p = 0.55075A^{0.26998}L^{0.42612}S^{-0.06032}, \quad (\text{D.3})$$

$$Q_p = 93.22352A^{0.83576}L^{-0.326}S^{0.5}, \quad (\text{D.4})$$

where A is the drainage area in square miles, L is the main channel length in miles, and S is the main channel slope in ft/mile. The ordinates for the gamma unit hydrograph are

$$Q = Q_p \left(\frac{t}{T_p} \right)^\alpha e^{\left(1 - \frac{t}{T_p}\right)\alpha}, \quad (\text{D.5})$$

where Q is the discharge ordinate of the gamma unit hydrograph at time t and α is the shape parameter. The three gamma unit hydrograph parameters (Q_p , T_p , and α) are not independent. The shape factor can be determined from Q_p and T_p (Aron and White, 1982).

The Clark (1943) instantaneous unit hydrograph (IUH) method is one unit hydrograph included in the both the HEC-1 (Hydrologic Engineering Center, 1998) and HEC-HMS (U.S. Army Corps of Engineers, 2006) general hydrologic modeling software systems. If a watershed specific time-area histogram is not available for a watershed of interest, a “standard” or synthetic time-area histogram is embedded within the software. The form of the synthetic time-area histogram is

$$\frac{A_t}{A} = \begin{cases} \sqrt{2} \left(\frac{t}{T_c} \right)^{1.5} & t \leq \frac{T_c}{2} \\ 1 - \sqrt{2} \left(1 - \frac{t}{T_c} \right)^{1.5} & t > \frac{T_c}{2} \end{cases} \quad (\text{D.6})$$

where A_t/A is the fraction of the watershed contributing flow to the outlet at time t . These equations are applicable to most basins (Bedient and Huber, 2002). The resulting unit hydrograph is a translation hydrograph and no accounting for watershed storage is included. The standard Clark approach (also implemented in HEC-1 and HEC-HMS) is to route the resulting translation unit hydrograph through a linear reservoir (with a parameter to be determined by watershed storage) before applying the result to convolution. In the following, the translation unit hydrograph was used without the linear reservoir routing.

Three unit hydrographs developed using the above methods are depicted on Figure D.8 for USGS streamflow-gaging station 08048600. The shape of the UH from MRM (pink) is trapezoidal, in contrast to those from the Clark method (blue) and from the gamma unit hydrograph method (green), which are smooth curves. The peak discharge (Q_p) of UH estimated by three different models are different but the area under the curves is the same corresponding to 1 watershed inch of excess rainfall.

Gamma, MRM, and Clark unit hydrographs developed for each watershed were applied to recorded rainfall events to generate direct runoff hydrographs. The constant fraction rainfall loss method (the rational method) was used to estimate the rainfall excess hyetograph for each rainfall event. The C_v^{bc} runoff coefficient determined for each event was used for this portion of the study. Both the MRM and Clark unit hydrograph methods require watershed time of concentration (T_c) as an input parameter. Therefore, T_c determined using the Kerby-Kirpich method was used. The observed and simulated direct runoff hydrographs for three rainfall events by the three models are displayed on Figures D.9 and D.10. For these computations, base flow was assumed to be zero.

The unit hydrographs generated by three methods differ because they are based on different assumptions. For the event on 4/16/1969 (Figure D.9), runoff hydrographs simulated differ because they are resulted from only three rainfall impulses. There are an insufficient number of convolution

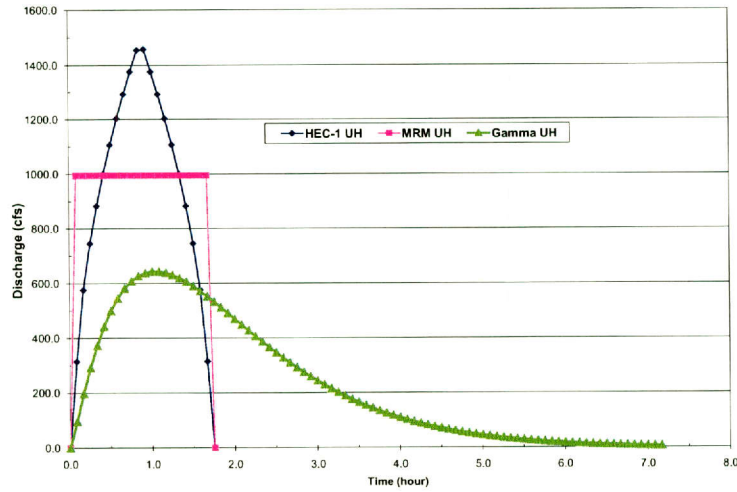

Figure D.8: Unit hydrographs for USGS Streamflow-gaging Station 08048600. The unit hydrographs are: MRM (pink), gamma (green) and Clark (blue).

intervals to produce the smooth curves expected from unit hydrograph/hydrograph convolution. For the event on 9/14/1966 (Figure D.9), simulated runoff hydrographs result from a greater number of convolution intervals (17 impulses over an 85-minute period).

Simulated runoff hydrographs for the 85-hour rainfall event starting on 9/14/1966 at the USGS streamflow-gaging station 08139000 (Deep Creek, Colorado Basin, Texas) are displayed on Figure D.10. Although there are differences between the methods and between the simulated and observed hydrographs, the impact of unit hydrograph method is absorbed into the hydrograph/hydrograph convolution process and the results are indistinguishable regardless of the unit hydrograph model used. The four distinct rainfall episodes resulted in four distinct discharge peaks that are reasonably represented by results from three unit hydrograph models. For time to peak discharge, simulated ones using three methods agree reasonably well with observed one. Simulated peak discharges by three methods are similar. Additionally, the area under three simulated hydrographs is the same matching well with the observed curve because event C_v^{bc} was used. Finally, the drainage area of these two watersheds is greater than that usually accepted for rational method application, yet results from the modified rational method reasonably approximate watershed behavior.

Unit hydrographs for all 90 watersheds in the study database were developed using the three unit hydrograph approaches, gamma, Clark, and MRM. The resulting unit hydrographs were applied to approximately 1,600 observed rainfall events. The C_v^{bc} runoff coefficient was used to model the rainfall-runoff process for each event. The Kerby-Kirpich method was used to estimate time of concentration for the Clark and MRM unit hydrograph approaches. Modeled and observed peak discharges are displayed on Figure D.11. The green triangles represent results from the MRM unit hydrograph model and the black circles are the results from the Clark unit hydrograph model. There is negligible difference in the results; they almost overlap each other. Similarly, Figure D.12 is a plot of computed and observed peak discharges using the MRM unit hydrograph model (green

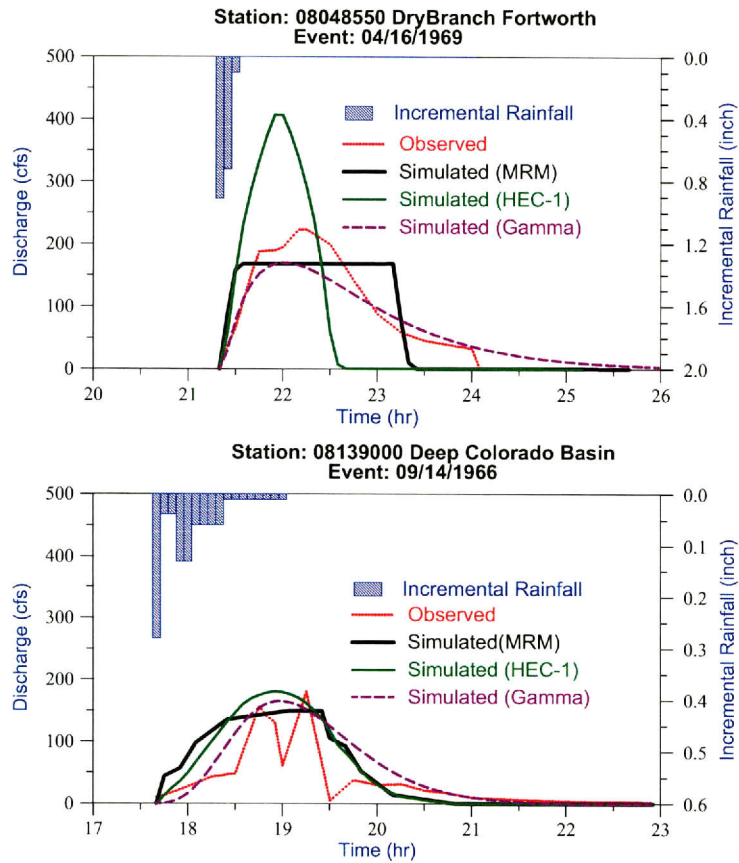

Figure D.9: Incremental rainfall hyetographs and observed (red) and simulated runoff hydrographs using the modified rational method (black), gamma unit hydrograph (purple) and Clark unit hydrograph (green). Upper panel is for the event on 4/16/1969 at the USGS streamflow-gaging station 08048550 Dry Branch, Fort Worth, Texas. Lower panel is for the event on 9/14/1966 at the USGS streamflow-gaging station 08139000 Deep Creek, Colorado Basin, Texas.

triangles) and the gamma unit hydrograph model (black circles). The cumulative distributions of differences of simulated Q_p from different methods indicates that simulated peak discharges are very similar regardless of the choice of unit hydrograph as shown on Figure D.13.

General conclusions for the modified rational method is:

1. The modified rational method is a special case of the unit hydrograph,
2. The modified rational method, being a unit hydrograph, can be applied to non-uniform rainfall events and for watersheds with drainage areas that exceed that typically used for the rational method (a few hundred acres), and
3. The modified rational method performs about as well as other unit hydrograph methods,

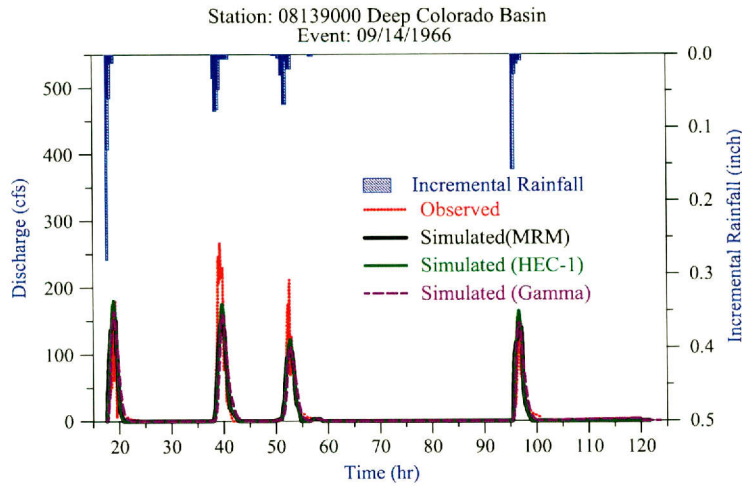

Figure D.10: Incremental rainfall hyetographs and observed (red) and simulated runoff hydrographs using the modified rational method (black), gamma unit hydrograph (purple) and HEC unit hydrograph (green) for USGS streamflow-gaging station 08139000 Deep Creek, Colorado Basin, Texas.

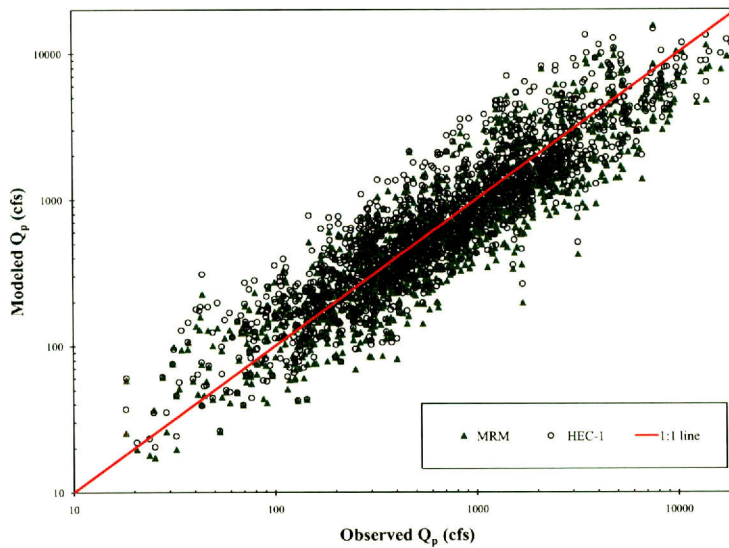

Figure D.11: Modeled and observed peak discharge from modified rational method (green) and HEC-1 unit hydrograph method (black).

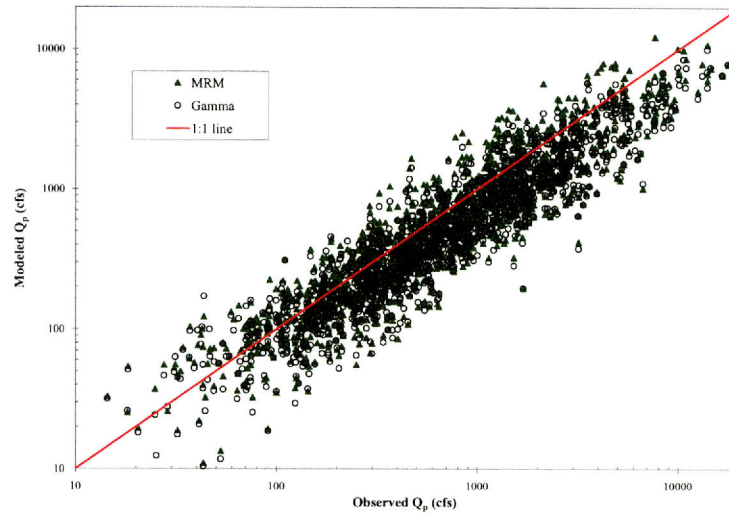

Figure D.12: Modeled and observed peak discharge from modified rational method (green) and gamma unit hydrograph method (black).

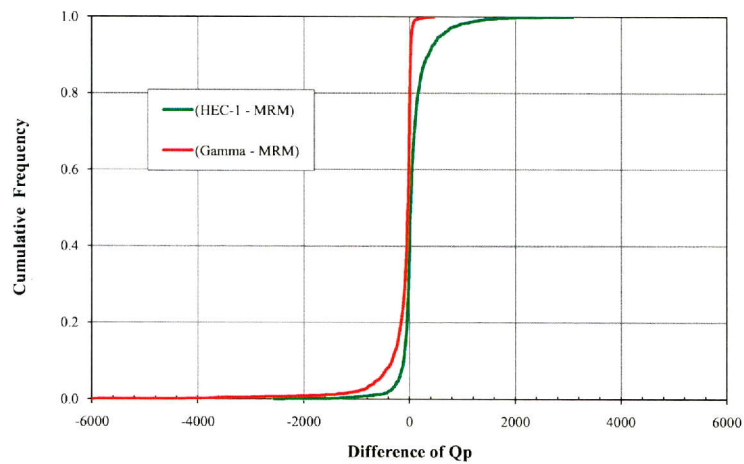

Figure D.13: Cumulative distributions of differences of simulated Q_p between different methods. The green curve is for differences of simulated Q_p between Clark and MRM unit hydrographs, and the red curve is for differences of simulated Q_p between gamma and MRM unit hydrographs.

such as the gamma and Clark methods, in prediction of peak discharge of the direct runoff hydrograph, when the same loss model is used to compute effective precipitation.



TEXAS TECH UNIVERSITY
Multidisciplinary Research in Transportation

Texas Tech University | Lubbock, Texas 79409
P 806.742.3503 | F 806.742.4168