



Feasibility Study of Two-Lift Concrete Paving: Technical Report

Technical Report 0-6749-1
Cooperative Research Program

TEXAS STATE UNIVERSITY—SAN MARCOS
THE TEXAS STATE UNIVERSITY SYSTEM
SAN MARCOS, TEXAS 78666-4684

CENTER FOR TRANSPORTATION RESEARCH
THE UNIVERSITY OF TEXAS AT AUSTIN
3208 RED RIVER, SUITE 200
AUSTIN, TX 78705-2650

in cooperation with the
Federal Highway Administration and the
Texas Department of Transportation
<http://tti.tamu.edu/documents/0-6749-1.pdf>

1. Report No. FHWA/TX-14/0-6749-1		2. Government Accession No.		3. Recipient's Catalog No.	
4. Title and Subtitle FEASIBILITY STUDY OF TWO-LIFT CONCRETE PAVING: TECHNICAL REPORT				5. Report Date Published: April 2014	
				6. Performing Organization Code	
7. Author(s) Jiong Hu, David Fowler, Md Sarwar Siddiqui, and David Whitney				8. Performing Organization Report No. Report 0-6749-1	
9. Performing Organization Name and Address Texas State University-San Marcos The Texas State University System San Marcos, Texas 78666-4684 Center for Transportation Research The University of Texas at Austin 3208 Red River, Suite 200 Austin, TX 78705-2650				10. Work Unit No. (TRAIS)	
				11. Contract or Grant No. Project 0-6749	
12. Sponsoring Agency Name and Address Texas Department of Transportation Research and Technology Implementation Office 125 E. 11 th Street Austin, Texas 78701-2483				13. Type of Report and Period Covered Technical Report: September 2012–August 2013	
				14. Sponsoring Agency Code	
15. Supplementary Notes Project performed in cooperation with the Texas Department of Transportation and the Federal Highway Administration. Project Title: Feasibility Study of Two-Lift Concrete Paving URL: http://tti.tamu.edu/documents/0-6749-1.pdf					
16. Abstract Two-lift concrete paving (2LCP) involves placing two layers of concrete (wet-on-wet) instead of a single homogeneous layer, as is typically done in the United States. 2LCP offers the opportunity to optimize the use of local aggregates, recycled materials to produce an economical, durable, and sustainable pavement system with the most desirable surface characteristics (improved skid resistance and reduced noise). Districts including Houston, Fort Worth, and Dallas have the potential to receive great benefit from the concept by being able to use more local materials that is not considered appropriate for traditional (single-lift) concrete pavement used. Despite of above mentioned benefits, challenges of 2LCP are to have the proper paving equipment, pavement construction management, the right mixture proportions to use the local materials in the bottom lift, which results in an economical pavement placement, and the proper proportions and materials to ensure adequate surface friction and abrasion resistance in the top lift. A comprehensive literature review was conducted to gather previous experiences and past performance of 2LCP, particularly to justify the cost and efficiently execute the process of 2LCP. Surveys and interviews were conducted on contractors and agencies with experience with 2LCP. A one-day workshop regarding 2LCP was organized to obtain information from a wide range of agency, construction, equipment manufacturer, and Texas Department of Transportation (TxDOT) personnel with experience or interests in 2LCP. The workshop also served as a solicitation of ideas of the best practice, most cost effective approach, concerns, and requirements associated with materials and construction of 2LCP. Information and inputs collected from literature reviews, surveys, interviews, and the 2LCP workshop were summarized to provide construction perspectives of implementation of 2LCP, including additional costs, requirements, and impacts to project scheduling of implementation of this concept. This report discusses additional requirements in materials, equipment and construction, project scheduling, and jobsite management that will be beneficial in the implementation of 2LCP construction. This study also evaluated feasibility and cost effectiveness of 2LCP, particularly in Texas.					
17. Key Words Two-Lift, Paving, Concrete, Cost, Construction			18. Distribution Statement No restrictions. This document is available to the public through NTIS: National Technical Information Service Alexandria, Virginia 22312 http://www.ntis.gov		
19. Security Classif. (of this report) Unclassified		20. Security Classif. (of this page) Unclassified		21. No. of Pages 126	22. Price

**FEASIBILITY STUDY OF TWO-LIFT CONCRETE PAVING:
TECHNICAL REPORT**

by

Jiong Hu, Ph.D.
Assistant Professor
Texas State University

David Fowler, Ph.D.
Professor
Center for Transportation Research
The University of Texas at Austin

Md Sarwar Siddiqui
Graduate Assistant
Center for Transportation Research
The University of Texas at Austin

and

David Whitney
Research Engineer
Center for Transportation Research
The University of Texas at Austin

Report 0-6749-1
Project 0-6749

Project Title: Feasibility Study of Two-Lift Concrete Paving

Performed in cooperation with
The Texas Department of Transportation
and
The Federal Highway Administration

Published: April 2014

TEXAS STATE UNIVERSITY
THE TEXAS STATE UNIVERSITY SYSTEM

and

THE CENTER FOR TRANSPORTATION RESEARCH
THE UNIVERSITY OF TEXAS AT AUSTIN

DISCLAIMER

This research was performed in cooperation with the Texas Department of Transportation (TxDOT) and the Federal Highway Administration (FHWA). The contents of this report reflect the views of the authors, who are responsible for the facts and the accuracy of the data presented herein. The contents do not necessarily reflect the official view or policies of the FHWA or TxDOT. This report does not constitute a standard, specification, or regulation. The researcher in charge of the project was Jiong Hu.

ACKNOWLEDGMENTS

This project was conducted in cooperation with the Texas Department of Transportation (TxDOT) and the Federal Highway Administration (FHWA). The authors wish to acknowledge the support of the TxDOT for funding this research. Special thanks are extended to TxDOT personnel for their support throughout this study, particularly Darrin Jensen and German Claros as the project manager, Darlene Goehl, Elizabeth Lukefahr, Clifford Halvorsen, Hua Chen, Andy Naranjo as Project Management Committee members, and Frank Espinosa as contract specialist. The authors would also like to thank Mr. Michael Grams, Dr. Soon-Jae Lee, and Dr. Yoo Jae Kim for their assistance in this project.

TABLE OF CONTENTS

	Page
List of Figures	ix
List of Tables	x
Chapter 1. Introduction	1
Research Background	1
Research Objectives.....	1
Research Approaches.....	2
Literature Review.....	3
Surveys.....	3
Workshop.....	4
Scope of Research and Organization of the Report.....	5
Chapter 2. General Aspects of Two-Lift Concrete Paving	7
What Is 2LCP?.....	7
General Experience.....	8
Potential Benefits of 2LCP	16
Use of Local/Recycled Aggregate	16
Use of Lower Cement and Higher SCMs Content.....	19
Surface and Ride Improvement	20
Longevity	21
Other Innovative Techniques.....	21
Potential Challenges and Concerns of 2LCP	21
Material Requirements.....	22
Durability	22
Equipment.....	22
Construction and Scheduling	23
Costs.....	24
Other Concerns	25
Chapter 3. Construction Prospective of Implementation of 2LCP	27
Additional Material and Pavement Requirements	27
Lift Thickness	27
Materials Selection and Mix Proportions	27
Materials Characteristics.....	28
Surface Characteristics.....	29
Pavement Design	29
Additional Equipment and Construction Requirements	29
Equipment Requirement	30
Mixing and Mix Delivery	32
Layer Placement Timing.....	32
Paving Operations.....	33
Surface Preparation.....	34
Reinforcement.....	35
Impact on Project Scheduling of Implementation of 2LCP.....	36
Planning and Scheduling.....	36
Jobsite Management.....	36

Chapter 4. Cost Effectiveness of 2LCP	37
General Cost Perspectives of 2LCP	37
Cost Information from Previous 2LCP Projects	38
Cost Analysis	40
Chapter 5. Best Practices of 2LCP	47
Feasibility of 2LCP	47
Considerations for Pavement Type Selection	47
Recommended practices for 2LCP implementation	48
Chapter 6. Conclusions and Recommendations	51
Conclusions	51
Recommendations for Future Researches	52
References	53
Appendix A Case Studies	57
Appendix B Survey A Questions	77
Appendix C List of Personnel in Survey A	83
Appendix D Summary of Survey A Results	85
Appendix E Survey B Questions	93
Appendix F List of Personnel in Survey B	97
Appendix G Survey B Summary	99
Appendix H Workshop Agenda	103
Appendix I Summary of Workshop	105
Appendix J List of Workshop Attendees	113
Appendix K Workshop Exit Survey Summary	115

LIST OF FIGURES

	Page
Figure 1. Typical 2LCP Construction and Pavement Cross Section (Photo Courtesy of Taylor [2013]).	7
Figure 2. Cross Section of Two-Lift Section in Belknap Place, San Antonio (Ciggelakis et al. 2013; Taylor 2013).	8
Figure 3. 2LCP with Welded Wire Mesh Reinforcement (I-80 Dallas County, Iowa 1966) (Grove and Taylor 2010).	9
Figure 4. Potential Problem of Using Soft Fine Aggregate in Single-Lift Paving.	18
Figure 5. TxDOT Districts with Local Aggregates Not Appropriate for Conventional Concrete Paving.	19
Figure 6. Exposed Aggregate Concrete (EAC) (Rasmussen 2008).	20
Figure 7. Construction Operations Involving Two Pavers Assembled as a Train versus a Paver with a 2LCP Implement.	23
Figure 8. Two-Lift Pavement Delamination on I-30 at Sulphur Springs, TX (Photo Adopted from Dr. Moon Won).	24
Figure 9. Gomaco GP-4000 Single Paver 2LCP System (Picture from Klein 2013).	31
Figure 10. Envelope Outside Edges of Bottom Lifts (Adopted from Gillen and Vavrik 2012).	34
Figure 11. EAC Construction in Minnesota I-95 Project (Rao and Darter 2012).	35
Figure 12. Comparison of Total Construction Cost for 12-in. CRCP and 2LCP for Varying Top-Lift (TL) Thickness.	41
Figure 13. Material and Construction Cost of 12-in. Concrete Pavement.	42
Figure 14. Comparison of Total Construction Cost for 12-in. CRCP and 2LCP, Lean Concrete at the Bottom-Lift.	43
Figure 15. Effect of Pavement Thickness on the Total Construction Cost of CRCP and 2LCP.	44
Figure 16. Framework of a Flow Chart for 2LCP Decision.	48
Figure 17. Paving Operation in Florida US-41 2LCP Construction (Greene et al. 2010).	59
Figure 18. Different Lift Thicknesses and Characteristics (Rens et al. 2008).	64
Figure 19. CRCP Construction in E34 Motorway Construction (Ren 2008).	65
Figure 20. 2LCP construction in Kansas I-70 Project (Gerhardt 2013).	67
Figure 21. Cross Section of 2LCP Section in Minnesota I-94 Project (Rao and Darter 2011).	70
Figure 22. Paving Train Constructing R21 Research Sections along I-94 at MnRoad (Tompkins et al. 2011).	71
Figure 23. 2LCP Construction in Illinois Tollway (Photo Courtesy of Meininger).	75

LIST OF TABLES

	Page
Table 1. Characteristics of Previous 2LCP Project Pavement (General Information).	12
Table 2. Case Studies for 2LCP Projects.	15
Table 3. Statistics of 2LCP Material and Pavement Characteristics.	15
Table 4. Cost Comparisons from Selected 2LCP Projects.	39
Table 5. Recommend Practices for 2LCP Implementation.	49
Table 6. Summary of Experimental Section (Greene et al. 2011).	58
Table 7. Properties of Concrete and Econocrete (Greene et al. 2011)	59
Table 8. Mix Design for Belgium E-34 Motorway Project.	64
Table 9. Mix Design for Kansas I-70 2008 Project (Vanikar 2010).	66
Table 10. Cost Comparison of Standard Paving and 2LCP from Kansas 2008 Project.	68
Table 11. SHRP2 R21 PCC/PCC Design for MnRoad Sections.	70
Table 12. Cost Comparison from MnRoad SHRP2 2010 Project.	72
Table 13. Comparison of Equipment Requirements from MnRoad I-94 Project (Krummen 2012).	73
Table 14. Cost Comparison of 2LCP vs. Traditional Paving in Illinois Tollway Project (Rao 2013).	76
Table 15. List of Personnel in Survey A.	83
Table 16. Summary of Information Collected from Survey A.	88
Table 17. Comments Regarding Needs for 2LCP.	90
Table 18. Additional Comments Regarding 2LCP.	91
Table 19. List of Personnel in Survey B.	97
Table 20. Summary of Information Collected from Survey B.	100
Table 21. List of in Person Attendees of the 2LCP Workshop.	113
Table 22. List of Remote Attendees of the 2LCP Workshop.	114
Table 23. Summary of the Exit Survey of the 2LCP Workshop.	115

CHAPTER 1. INTRODUCTION

RESEARCH BACKGROUND

Two-lift concrete paving (2LCP) involves placing two layers of concrete (“fresh-on-fresh” or “wet-on-wet”) rather than the traditional method of using a single, homogeneous layer of concrete that is commonly used in the United States. The bottom layer is generally thicker and consists of lower quality concrete mixtures or aggregate, in many cases recycled aggregate or local aggregates that are not suitable to use in surface courses. The top layer is thin and consists of high-quality concrete and aggregate, often imported, that provides better durability, reduced noise, and improved skid resistance. 2LCP will reduce material costs by being able to consume more local materials including low quality aggregates, recycled concrete aggregate (RCA), and reclaimed asphalt pavement (RAP) that would not be suitable as a wearing surface and also provide quality surface characteristics (i.e., reduce noise, increase wear-resistance). While users of 2LCP enjoying benefits of improved safety, noise and economic, there are also concerns including extra equipment (costs), site management, and materials restrictions. The purpose of this study is to deliver a feasibility analysis and cost assessment of this alternative method of paving with current equipment and materials, but using more of plentiful local resources (that might not be suitable as the surface course), instead of relying so much on imported materials. This is particularly true for the Dallas/Fort Worth Metropolis, where good natural siliceous sand is in short supply. The results of this study enables the Texas Department of Transportation (TxDOT) to use more of the presently less desirable aggregates, while increasing their efforts to provide more demand for local materials and thus stimulate local economies where concrete pavements are located. This summary of best practices of 2LCP helps TxDOT management and pavement engineers in determining how and when a 2LCP is cost effective and in the best interest of the public.

RESEARCH OBJECTIVES

This study evaluates feasibility and cost effectiveness of 2LCP, particularly in Texas. There are five primary technical objectives in this project:

1. To determine how other countries like France, Austria, and Germany, justify the cost and efficiently execute the process of 2LCP.

2. To determine additional requirements regarding the implementation of 2LCP.
3. To determine additional costs of 2LCP from extra equipment and construction management.
4. To determine how the overall cost of 2LCP compares with long hauling imported aggregates under the current system.
5. To determine any impacts to project scheduling that can be attributed to this construction process.

The results of this research study will have an excellent opportunity to be implemented. With the rapid depletion of quality natural sand and aggregates in several parts of Texas, 2LCP is an obvious solution by using locally available aggregates in the bottom lift and using higher quality aggregates to ensure good surface friction and long life in the top lift. The research provides guidelines and draft specifications that can be incorporated by TxDOT to make more efficient use of locally available aggregate resources and at the same time can build good quality pavement with a longer service life.

RESEARCH APPROACHES

A comprehensive literature survey was first conducted to summarize advantages, disadvantages, and cost effectiveness of 2LCP, particularly to justify the cost and efficiently execute the process of 2LCP. Previous experiences and past performance of 2LCP was also summarized. The state-of-the-practice of 2LCP was evaluated through direct communication of agency, construction, and equipment personnel with experiences of 2LCP. Surveys and interviews were conducted to determine experiences of contractors and agencies with 2LCP and to determine TxDOT personnel's concerns on implementation of 2LCP. A workshop was also hosted for sharing ideas of the best practices, most cost effective approach, concerns, and requirements associated with materials and construction of 2LCP. Information and inputs collected from surveys, interviews, and the 2LCP workshop were summarized to provide construction perspectives of implementation of 2LCP, including additional costs, requirements, and impacts to project scheduling of implementation of this concept. Researchers conducted a cost effectiveness analysis and feasibility study of the most promising 2LCP practice. The following sections describe specific research approaches of literature review, surveys, and workshop.

Literature Review

Researchers first conducted a thorough literature survey to evaluate 2LCP from a global perspective. Literature was collected from research articles, project reports, and other project documents through direct contact with agencies and contractors involved with the projects. The comprehensive literature review collected project-based information including thicknesses and materials used for different lifts, sizes and costs of projects, materials uses, pavement characteristics, extra equipment, and construction management issues related to the 2LCP application. Results were incorporated into an annotated bibliography including summary tables and figures. Statistical analysis was also performed to quantify 2LCP characteristics, including materials, pavements, and construction processes. Detailed information including project background, material and pavement characteristics, construction, and cost details of selected projects were included as case studies and presented in Appendix A.

Surveys

The research team developed two sets of questions in order to obtain additional information and insights concerning the application of 2LCP. Survey Monkey® was used to conduct online surveys. Phone interviews with the same two set of questions were also used if needed.

The first set of questions (Survey A) targets contractors and agencies with experiences on working with 2LCP. The research team identified and contacted representatives from agencies, construction firms, and pavement equipment manufacturers with experience in the construction of 2LCP. Representatives were asked to provide information regarding:

- 2LCP design and construction problems.
- Field performance in general and specifically pavements subjected to high levels of equivalent single axel loads (ESALs).
- Experience with different thicknesses and different quality concrete with respect to effects of mechanical properties and coefficient of thermal expansion (CoTE).
- Realistic cost differences between 2LCP and conventional single-lift concrete pavements.

A total of 25 individuals participated the survey. Appendix B, C, and D provide the detailed survey questions, a list of personnel that participated the survey, and a summary of survey results, respectively.

The second set of questions (Survey B) targets TxDOT personnel and Texas paving contractors with concerns in implementation of 2LCP in Texas. Similar to Survey A, researchers contacted via email and telephone any interested contractors and TxDOT personnel from the larger urban districts and the Construction Division's Pavements and Materials and Tests for their initial inputs regarding concerns with 2LCP. Representatives identified as contractors were also asked to provide their opinions on the possibility of implement the 2LCP technology, issues viewed important to implement the 2LCP technology, and barriers, if any, to implementation. A total of 32 individuals participated this survey. Appendix E, F, and G provide the detailed survey questions, a list of personnel that participated the survey, and a summary of survey results, respectively.

Workshop

Upon the completion of surveys and interviews, the research team hosted a one-day workshop to obtain information from a wide range of agency, construction, and equipment representatives regarding 2LCP. The workshop was also organized in order to provide TxDOT personnel and contractors with direct communication with representatives with experiences of 2LCP and helped to formulate ideas and guidelines for further study.

Major activities of the workshop included an update of findings from the research team regarding previous uses and experiences 2LCP, presentations from experts with 2LCP experiences, and organized discussions to obtain input of all participants, recap of major issues, findings, and summary of action items to achieve the goal of successful 2LCP. The eight presentations covered TxDOT perspectives, introduction to designer's viewpoints, environmental performance, agency viewpoints, contractors' viewpoints, pavement equipment, and research. Discussions in the workshop served as solicitation of ideas on the most cost effective approach, material, and environmental concerns, QC/QA monitoring, and the issues to be covered in 2LCP implementations. In addition to onsite attendance, both online and conference call options were provided. A total of 51 personnel participated the workshop, which included state and district engineers, pavement engineers, paving contractors, pavement equipment manufacturers,

representatives of Federal Highway Administration (FHWA), Texas Concrete Pavement Association (TCPA), and the American Concrete Pavement Association (ACPA). An exit survey was conducted after the workshop. Appendix H, I, and J provide the workshop agenda, a list of attendees, and a summary of the workshop, respectively.

SCOPE OF RESEARCH AND ORGANIZATION OF THE REPORT

The following describes the report's organization by chapter:

- Chapter 1 presents the general background, research objectives, research approaches, and scope of the project.
- Chapter 2 summarizes the general concept, history, experiences, potential benefits and challenges, and concerns of 2LCP.
- Chapter 3 summarizes the construction perspective of implementation of 2LCP.
- Chapter 4 summarizes the cost effectiveness of 2LCP.
- Chapter 5 summarizes the best practices of 2LCP.
- Chapter 6 summarizes major findings and conclusions from the study. Recommendations for future research and 2LCP implementation are also presented.

CHAPTER 2. GENERAL ASPECTS OF TWO-LIFT CONCRETE PAVING

WHAT IS 2LCP?

As shown in Figure 1, 2LCP involves the placement of two wet-on-wet layers of concrete instead of the homogeneous single-lift that is most commonly placed in concrete paving. With 2LCP, a thicker bottom layer usually contains aggregate of lesser quality, lower durability or strength, locally available aggregate, or more often, recycled aggregate. A thinner top layer usually consists of premium aggregate, often non-local source, designed to provide superior durability as well as noise reduction and improved traction.

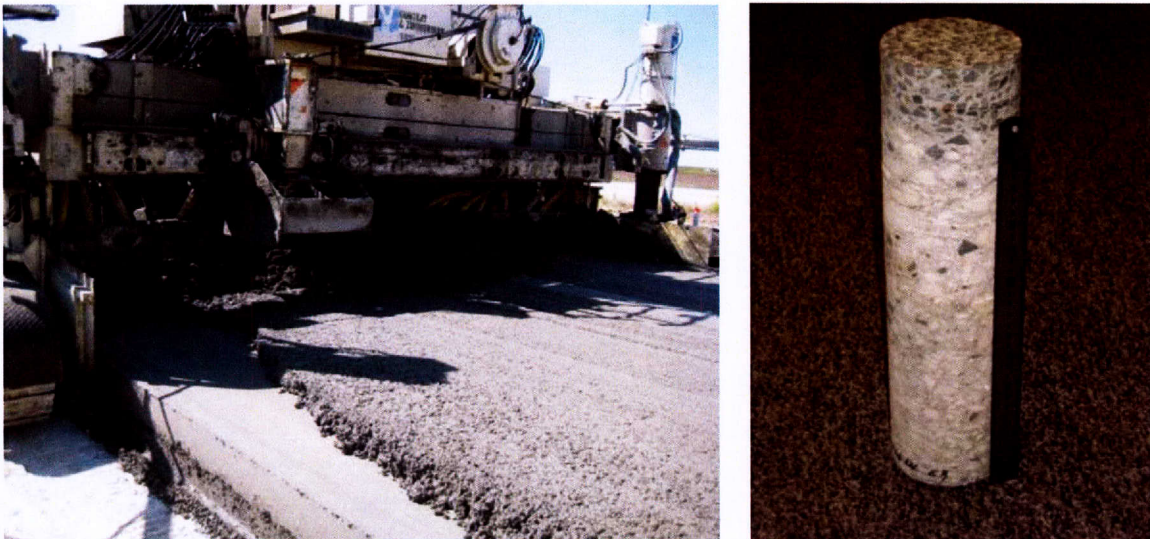

Figure 1. Typical 2LCP Construction and Pavement Cross Section (Photo Courtesy of Taylor [2013]).

By using local aggregates that are generally not acceptable for a surface layer (including soft limestone aggregate, high CoTE siliceous gravels, and recycled materials), 2LCP minimizes the need for new aggregate and cuts down on material and energy costs and landfill waste. It also reduces the truck traffic required to haul new aggregate to the construction site. 2LCP also allows the use of concrete with relatively low cement content and higher water-to-cement ratio (w/c), as well as a higher amount of supplemental cementitious materials (SCMs) in the bottom lift. Another common application of modern 2LCP is to provide a relatively quiet, high-friction pavement surface through the use of exposed aggregate concrete (EAC) (Rasmussen 2008; Castecker 1998). This application requires the use of extra-hard, wear-resistant aggregates, generally of a smaller than usual size. While the use of smaller aggregate requires increased

cement content, which increases the cost, these additional costs are usually minor due to the thinness of the top lift and can be offset by savings in the bottom lift, which uses local materials and lower cement contents (Tompkins et al. 2010).

GENERAL EXPERIENCE

Although uncommon today, 2LCP construction is not new to the U.S. The first U.S. two-lift concrete pavement was built in Bellefontaine, Ohio (Snell and Snell 2002). In the project, the bottom course was approximately 4 in. thick and had maximum size aggregate of 1.5 in. with a w/c of 0.60. The top course had maximum size aggregate of 0.5 in. and a w/c of 0.45. Another example is the 1914 Belknap Place project constructed in San Antonio, Texas, (Figure 2), which is still in service. During that period of early concrete pavement construction, 2LCP construction was chosen due to the lack of appropriate paving equipment. The practice gradually phased off as modern pavement construction equipment such as paving machines and slip-form pavers came into place.



Figure 2. Cross Section of Two-Lift Section in Belknap Place, San Antonio (Ciggelakis et al. 2013; Taylor 2013).

Note: Cores are placed upside down on Fig 2a

From the 1950s to 1970s, 2LCP was often used to facilitate the placement of welded wire mesh reinforcement in concrete highway pavements. After placing a first concrete layer, approximately half of the total thickness, crews would set the wire mesh on the wet concrete between dowel baskets (Figure 3). Before the first layer stiffened, a second layer of the same

concrete mix was placed on top of the mesh, and a paving machine then finished the surface. The practice was used successfully in several states; however, after the 1970s, concrete pavement design trends gradually moved away from mesh reinforcement, and the apparent need for the 2LCP practice disappeared (Cable and Frentress 2004; Hall et al. 2007; Shields-Cook and Taylor 2009).



Figure 3. 2LCP with Welded Wire Mesh Reinforcement (I-80 Dallas County, Iowa 1966) (Grove and Taylor 2010).

While the 2LCP depleted from the U.S., the same concept has been successfully adopted in a number of European countries, including Austria, Belgium, Germany, and the Netherlands, since the 1930s. Austria in particular uses this method as their standard method of pavement construction. They developed and adopted a two-lift concrete pavement system that used the crushed pavement (both asphalt and concrete) particles sized No. 4 to 1.25-in. in a 7.5-in. lower lift that was capped with a 1.2-in. surface layer of high-quality concrete, which was used to produce an exposed aggregate surface for friction and noise reduction. The crushed pavement fines (No. 4 minus) were mixed into the old pavement to stabilize it (Kreen and Stinglhammer 1994). Savings of natural materials on the first project alone were estimated at 205,000 metric tons of gravel, and associated savings of 30,000 trucking operations. Overall savings were estimated at a minimum of 10 percent when compared to the conventional use of natural aggregate (Kreen and Stinglhammer 1994). The success of this project led to the construction of

47 miles of roadway in the Salzburg and lower Austria provinces between 1991 and 1994, and 2LCP recycled materials in the lower lift is now standard practice in Austria. Austrian successes led to the increased use of this paving technique in other European countries (mainly in France and Germany, but also Belgium and others) where safety, noise, and economic reasons are cited as primary reasons for implementing the 2LCP method (Flintsch et al. 2008; Bilec et al. 2010).

With the success in Europe, the concept of 2LCP draws attention from the U.S. In 1992 and 2006, two scan tours were organized that gave participants the chance to observe the techniques and performance of 2LCP directly (FHWA 1992; FHWA 2007a). The first scan tour was organized in 1992, with 21 representatives from the U.S. interested in concrete pavements met with experts in France, Austria, Germany, the Netherlands, and Belgium. The group observed a variety of general strategies exhibited by European specifying agencies and studied specific technical aspects of rigid pavement design and construction. During the tour, one 2LCP project was observed in Austria using recycled concrete plus natural sand for the bottom lift and higher percentage of hard stone chips in the top lift (Darter 1993; FHWA 1992; Cole 1995). Over the past decade, agencies in the United States are taking another look at the 2LCP. Interests in 2LCP revived when a team of U.S. pavement experts visited Europe in 2006 for another international scanning study on long-life concrete pavements. The scan team included representatives of FHWA, state departments of transportation, the National Cooperative Highway Research Program, academia, and the consulting, cement, and concrete pavement industries. The scan team observed 2LCP in Austria, Belgium, Germany and the Netherlands, where the technique is used to build concrete pavements with good friction and noise characteristics, economize on the use of aggregates, and use reclaimed paving materials (Hooker 2011). The technique was also recently highlighted in a videoconference held by Iowa State University and the FHWA Highways for LIFE program and Office of Pavement Technology (Cackler 2007; FHWA 2007b). The FHWA is encouraging the use of two-lift construction through its Pavement Technology and Highways for LIFE programs. Not only does the practice help meet the Highways for LIFE goals of improving safety and highway quality, its use of recycled materials reduces highway congestion during construction. In addition to providing Highways for LIFE funding for projects that use innovations such as 2LCP, the FHWA is developing demonstration projects to encourage states to use the technology. A number of states

are considering using 2LCP on upcoming projects, including Florida, Georgia, Kansas, and Washington (FHWA 2007c; Kuennen 2008).

Experience with 2LCP in the United States is limited but increasing. In recent decades, several states have experimented with 2LCP to promote recycling and enhance the surface characteristics of pavements. While 2LCP has become a common practice for concrete pavement in Europe, most of the 2LCP projects in United States are demonstration projects and test sections. Through the literature review, approximately 20 2LCP projects were identified. Table 1 provides a brief summary of selected 2LCP projects that have been completed in European countries and the United States.

Table 1. Characteristics of Previous 2LCP Project Pavement (General Information).

	Project No.	Year	Country/ State	Highway/Location	EA C?	Length (mi.)	Width (ft)	Traffic (ADT)	Performance	References
European Experience	EU1	1989	Austria	Freeway A1	Y	NA				Cable and Frentress 2004; Vancura et al. 2009; Tompkins et al. 2009; Tompkins et al. 2010
	EU2	1994	Austria	A1 near Eugendorf	Y	NA		56,000		Tompkins et al. 2009; Akkari and Izevbehai 2011
	EU3	1994	Austria	A1 near Traun	Y	NA		55,000		Tompkins et al. 2009; Tompkins et al. 2010
	EU4	1999	Austria	A1 near Vorchdorf	Y	NA		56,000		Tompkins et al. 2009; Tompkins et al. 2010
	EU5	2003	Belgium	N511 at Estaimpuis*	Y	0.8		2,000		Debroux and Dumont 2005
	EU6	2005	Belgium	E34 motorway in Zwijndrecht *		1.9		23,000		Rens et al. 2008
	EU7	2008	Germany	A6 Near Amberg	Y	13.0		80,000		Tompkins et al. 2009; Tompkins et al. 2010
	EU8	NA	France	Highway A71		NA				Cable and Frentress 2004; Bilec et al. 2010
	EU9	NA	Germany	Munich Airport		NA				Cable and Frentress 2004; Bilec et al. 2010
US Experience	US1	1914	Texas	Belknap PL. San Antonio		0.8	40		In service	Ciggelakis et al. 2013
	US2	1976	Iowa	US 75		NA				Bilec et al. 2010
	US3	1976	North Dakota	US 2 between Rugby and Leeds		NA				Bilec et al. 2010
	US4	1977	Florida	US 41		2.5	24	11,000	Faulting/No faulting	Cable and Frentress 2004; Bilec et al. 2010
	US5	1993	Michigan	I-75, NB	Y	1.0	36			Bilec et al. 2010; Smiley 2010
	US6	1997	Kansas	K-96	Y	0.7	24	4,800		Cable and Frentress 2004; Wojakowski 1998
				K-96	Y	0.4	24	4,800		
				K-96	Y	0.8	24	4,800		
	US7	2008	Kansas	I-70 in Saline County	Y	5.0				CP Road Map 2010; Fick 2009; Taylor 2009
	US8	2008	Pennsylvania	Mon-Fayette Expressway		NA				Bilec et al. 2010
US9	2010	Minnesota	I-94, Cell 71	Y	NA		27,500		Akkari and Izevbehai 2011; Rao et al. 2013	
			I-94, Cell 72	Y	NA		27,500			
US10	2012	Illinois	Tollway		4.2				Rao 2013	
Avg						2.8	28.7	29,367		
Stdev						3.7	7.3	26,257		

*CRCP Section

Table 1. Characteristics of Previous 2LCP Project Pavement (Bottom Lift).

Project No.	Thickness (in.)	Aggregate	Cement (pcy)	SCM (pcy)	w/c	Slump (in.)	Air (%)	f'c (psi)	MOR (psi)
EU1	8.5	RCA and RAP							
EU2	8.3	RCA, MSA 1.26"							
EU3	7.9	RCA, MSA 1.26"							
EU4	8.3	RCA, MSA 1.26"							
EU5	6.0	Porphyry				0.59	5.0		
EU6	7.0	Broken stone, max 60% RCA							
EU7	10.0	River gravel							
EU8	NA	Local limestone							
EU9	9.5	Local gravel							
US1	NA	Gap graded pit run gravel (3/4"-1.5")							
US2	7.0	60% RCA, 40% RAP	470						
US3	6.0	NA							
US4	9.0	Limestone							371
US5	7.5	Dolomitic limestone			0.42			5,000	
US6	7.0	15% RAP	564		0.45			4,000	
	7.0	High abs. limestone	451	113	0.45			4,000	
	7.0	Limestone & pea gravel	564		0.45			4,000	
US7	11.8	Limestone				1.30	7.0		
US8	8.0	NA							
US9	6.0	50% RCA				1.00			
	6.0	Relaxed aggregate gradation				1.00			
US10	8.0	RAP& CM-11 Limestone				3.00	6.5	3,500	
Avg.	7.8		512	113	0.44	1.38	6.2	4,100	371
Stdev	1.5		60		0.02	0.94	1.0	548	

Table 1. Characteristics of Previous 2LCP Project Pavement (Top Lift).

Project No.	Thickness (in.)	Aggregate	Cement (pcy)	SCM (pcy)	w/c	Slump (in.)	Air (%)	f _c (psi)	MOR (psi)
EU1	1.6	Harder aggregate							
EU2	1.6	Diabase aggregate, MSA 0.31"							
EU3	2.0	Diabase aggregate, MSA 0.43"							
EU4	2.0	Diabase aggregate, MSA 0.43"							
EU5	2.0	Porphyry				1.2	4.0		
EU6	2.0	Broken stone, with polishing resistance requirement							
EU7	2.0	Crushed granite, gap-graded, MSA 0.31"							
EU8	2.0	Harder aggregates							
EU9	5.5	Crushed granite							
US1	NA	Very hard and dense black colored stone (3/8" to 1/2")							
US2	3.0	Gravel	564.0						
US3	3.0	Crushed rock and sand							
US4	3.0	Limestone							640
US5	2.5	Ontario trap rock (crushed basalt)	752.0		0.40			5,500	
US6	3.0	Limestone	564		0.45			4,000	
	3.0	Rhyolite	451	113	0.45			4,000	
	3.0	Limestone & pea gravel	564		0.39			4,000	
US7	1.6	Rhyolite				1.9	7.5		
US8	4.0	NA							
US9	3.0	1/2" and 3/8" W. Chips Granite				1.0		5,600	
	3.0	1/2" W. Chips and 3/8" W. Chips				1.0		5,600	
US10	3.5	CM-11 Limestone				3.0	6.5	3,500	
Avg.	2.7		579	113	0.42	1.6	6.0	4,600	640
Stdev	0.9		108		0.03	0.9	1.8	922	

Seven representative projects as listed in Table 2 were selected and included as case studies. Appendix A presents background, pavement characteristics, challenges, and lessons from the project and cost information.

Table 2. Case Studies for 2LCP Projects.

Project	Length (mi.)	T _{top} /T _{bot} (in.)	Bottom Lift Aggregate	Top Lift Aggregate
Florida US-41, 1977	2.5	3/9	Limestone	Limestone
Michigan I-75, 1993	1.0	3/7.5	Dolomitic limestone	Crushed basalt
Belgium E34 Motorway, 2005	1.9	2/7	Broken stone, max 60% RCA	Broken stone, with polishing resistance requirement
Kansas I-70, 2008	5	1.6/11.8	Limestone	Rhyolite
Pennsylvania Mon-Fayette Expressway, 2008	NA	4/8	NA	NA
Minnesota I-94, 2010	NA	3/6	50% RCA or Relaxed aggregate gradation	1/2" W. Chips and 3/8" W. Chips
Illinois Tollway, 2012	4.2	3.5/8	RAP & limestone	Limestone

Researchers performed statistical analyses on material and pavement characteristics based on the information collected through literature survey and interviews. Table 3 shows the results.

Table 3. Statistics of 2LCP Material and Pavement Characteristics.

	Top Lift		Bottom Lift	
	Avg.	Stdev	Avg.	Stdev
Thickness	2.6"	0.9"	7.8"	1.5"
Cement Content	579 pcy	108 pcy	512 pcy	60 pcy
w/c	0.42	0.03	0.44	0.02
Slump	1.6"	0.9"	1.38"	0.94"
Air	0.06	0.018	0.062	0.01
f _c	4,600psi	922psi	4,100psi	548psi
MOR*	640psi	NA	371psi	NA
Aggregate Type	High quality aggregate (granite, rhyolite, basalt, etc.)		Local aggregates (limestone sand, river gravel, RCA, RAP, etc.)	

* Only one datum available

POTENTIAL BENEFITS OF 2LCP

The two major benefits of 2LCP are: (1) permits concrete with lower unit cost to be used for the lower lift through allowing significant amounts of local materials, including aggregates that are considered not appropriate for surface courses including recycled and high CoTE coarse aggregates and carbonate fine aggregates, using lower cement contents and higher amounts of SCMs, and (2) more efficient and economical uses of specialized mixtures to produce desirable surface characteristics for the top lift with superior durability, reduced noise, and improved skid resistance. Following are major potential benefits of 2LCP.

Use of Local/Recycled Aggregate

One of the most significant advantages of the 2LCP is the practice uses local aggregate that is otherwise not suitable for traditional single-lift concrete paving. The concrete industry believes that the days of having virtually unlimited supplies of high class aggregates for concrete paving mixtures are behind us. Many of the best sources of this material have been depleted, resulting in shortages of locally available high class aggregates. Some suggested that these shortages might be (at least in part) alleviated by adopting 2LCP construction techniques where high class aggregate is used in a relatively thin surface lift while marginally acceptable aggregate is used in the thicker lower lift (Van Dam et al. 2011). The 2LCP can maximize the use of local materials, which in turn reduces the environmental impact from transporting materials. In 2LCP construction, while locally available aggregate including softer or high absorption limestone coarse and fine aggregate, relaxed aggregate gradation, and different levels of RCA and RAP replacement are commonly used in the bottom lifts, harder aggregate, including granite, basalt, and rhyolite that are often imported and used in the top lift in order to provide sufficient polishing resistance and higher durability.

TxDOT is facing rapidly depleting sources of natural siliceous river sand. Fine aggregates have the greatest influence on skid resistance in concrete pavements as softer carbonate fines tend to polish faster than harder silica aggregates. As shown in Figure 4, carbonate manufactured sands make good concrete but are not suitable for concrete pavement surfaces due to polishing. Districts with a large quantity of concrete pavements, such as Fort Worth and Dallas, have to (or likely will have to in the future) pay extra to haul natural siliceous sands from more than 100 miles in some instances. Siliceous sand can be used in 100 percent

natural sand mixtures or for blending with local manufactured sands to provide pavements with adequate wear-resistance, but they are becoming more expensive. Except on pavement surfaces where tires polish the concrete, the manufactured sands make good quality concrete. While TxDOT project 0-6255 (Use of Manufactured Sand for Concrete Paving) investigated the use of manufactured sand in the surface courses to provide concrete with acceptable skid resistance (Rached et al. 2010), 2LCP provides an alternative for the aggregate to be used in the bottom lift of concrete pavements. Manufactured sands have historically been regarded as a by-product of the crushing and screening operation. However, due to economic and environmental constraints, manufactured sands are becoming a more widely used product.

Manufactured carbonate fine aggregates are available in areas of Texas where natural sands have begun depleting; these areas include San Antonio, Dallas, and Fort Worth. Research conducted by the International Center for Aggregate Research (ICAR), has shown that manufactured carbonate fine aggregate can be used to produce concrete that has the same or better performance than concrete produced with siliceous river sand. The only concrete property that cannot be achieved using manufactured carbonate aggregate is long-term skid resistance for pavements. After the texture formed on the concrete surface is abraded, the skid resistance of a pavement is a function of the fine aggregate used in the concrete mixture.

To ensure good skid resistance, TxDOT has required that aggregate sources meet an acid insoluble (AI) residue test limit of 60 percent (Tex-612-J). When the AI test was introduced in the 1960s by Gray and Renninger (1965), it was used as a tool to identify the presence of carbonates (carbonates dissolve in acid). For this reason, carbonate aggregates fail AI and cannot be used in pavements without blending them with other aggregates. The presence of harder fine aggregates such as siliceous aggregates is only required at the surface of the concrete. In a 2LCP, a manufactured fine aggregate could be used in the bottom layer at 100 percent replacement, while a top layer can contain a 100 percent of an aggregate or a combination of two different sands that meets AI requirements. For example, project 0-6255 *Manufactured Sands in Concrete Pavements* indicated that in some cases, as little as 40 percent silica sand along with 60 percent carbonate sand has been found to provided long-term skid resistance. The 2LCP allows the use of softer manufactured sand in the bottom lift without endangering the wearing resistance of the pavement, which could be beneficial to areas that do not have sufficient sources of locally available good quality natural sand.

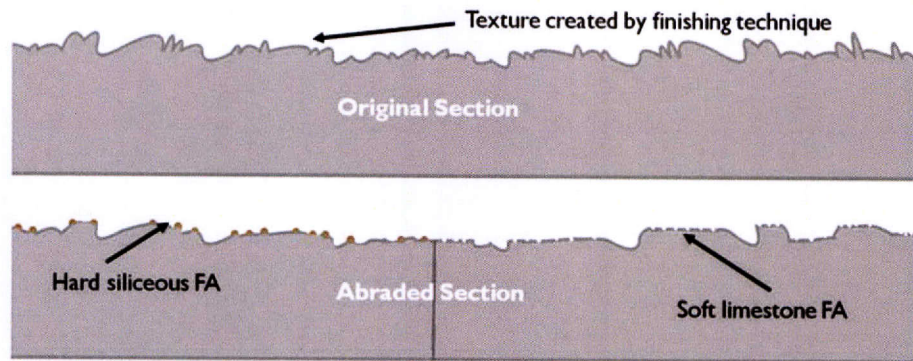

Figure 4. Potential Problem of Using Soft Fine Aggregate in Single-Lift Paving.

At the same time, our largest concrete pavement host, the Houston District, has many local sources of river gravel that are considered objectionable for new continuously reinforced concrete pavement (CRCP), because of their high CoTE. Houston must pay extra to haul limestone coarse aggregates from remote sources to make concrete roadways. A recently completed TxDOT project 0-6681 (Optimizing Concrete Pavement Type Selection Based on Aggregate Available) worked on providing guidelines in selecting pavement type based on aggregate sources. While it is known that high CoTE aggregate could cause potential spalling issues in CRCP, except for the top 2 to 3 in. of the pavement, where the greatest temperature and moisture changes take place, high CoTE materials such as siliceous gravel might be suitable for CRCP construction through 2LCP.

Another major advantage of 2LCP is the potential use of recycled aggregates in pavement construction. Two concerns when using RCA and RAP in concrete mixtures are increased water demand and premature stiffening of the mixture due to the presence of fine particles and the more absorptive nature of reclaimed mortar. While RCA and RAP are generally considered not appropriate for traditional single-lift concrete pavement, as shown in Table 1, there are already successful examples of using RCA and RAP in the bottom lift during 2LCP construction. The application can particular benefit major pavement reconstruction projects, whereas a higher level of quality control of RCA and RAP is possible.

As shown in Figure 5, the possibility of being able to use local aggregate in pavement construction can be useful to TxDOT. As some areas including Dallas and Fort Worth are faced with depleting sources of quality natural silica sands, blending may permit up to 60 percent carbonate fines in top lift and 100 percent in the bottom lift. Siliceous coarse aggregate in

districts such as Houston, Beaumont, and Atlanta with high CoTE can also be used in the bottom lift to minimize the potential of spalling or delamination. Previous experiences of 2LCP also indicated that use of RCA can be technically feasible to implement throughout Texas with a specific focus on Houston and Dallas/Fort Worth. While the concept of 2LCP provides an option of using aggregates that might not be appropriate for traditional concrete pavement, the practice can also be cost effective by reducing or minimizing transportation costs.

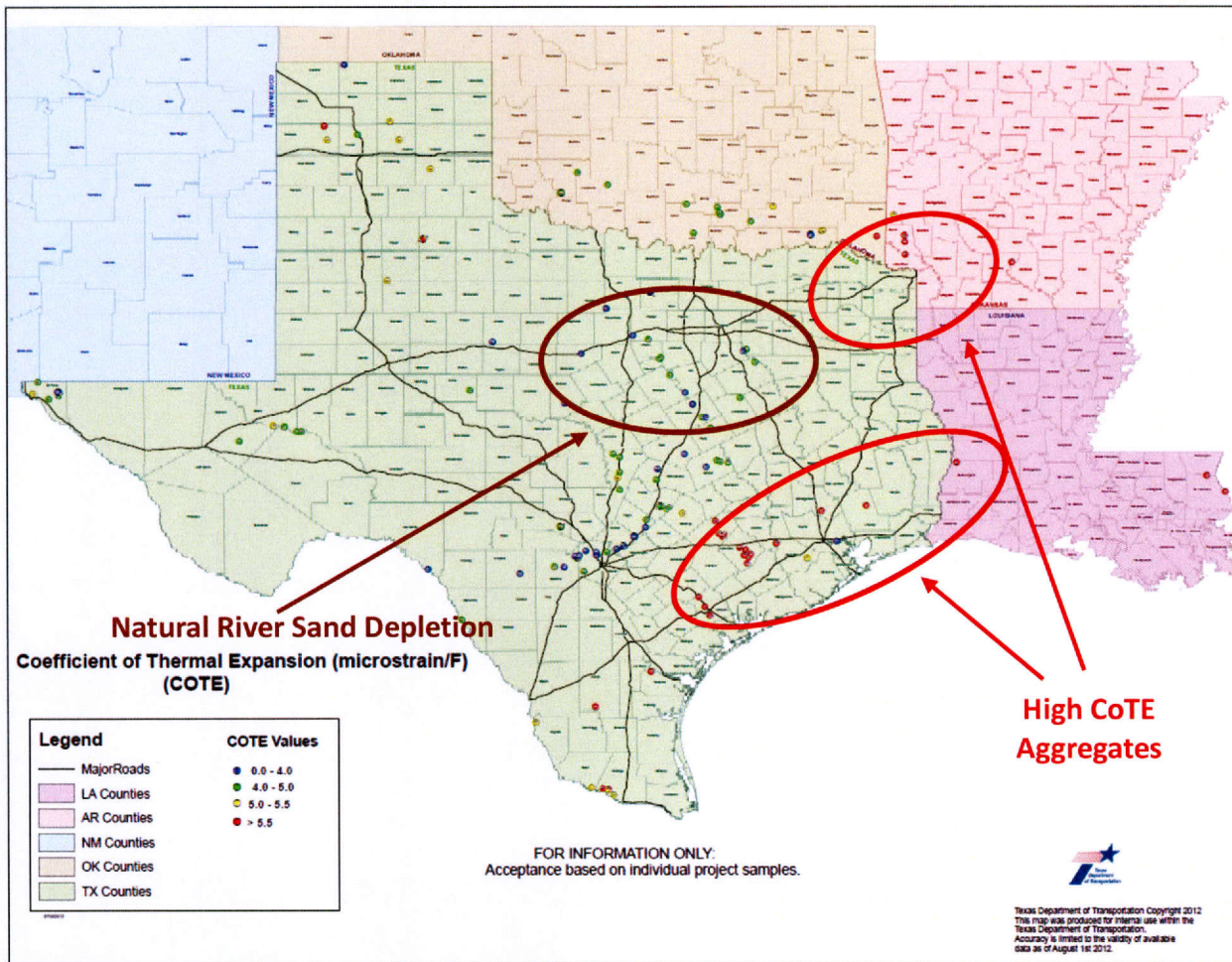

Figure 5. TxDOT Districts with Local Aggregates Not Appropriate for Conventional Concrete Paving.

Use of Lower Cement and Higher SCMs Content

In 2LCP construction, the concrete mix proportions for the bottom lift can be optimized knowing it will not be subjected to traffic and environment directly and will be protected from elements during construction as it will be capped with the top lift. This means that a lower

cement content, higher SCMs content, higher percentage of recycled aggregate and aggregate with less strength requirements (e.g., wear resistance) than normal can be used in the bottom lift. The top lift, on the other hand, often uses wear-resistance aggregate and higher cement content to ensure high durability and high skid resistance. Generally speaking, the required quality of concrete can be lowered in the bottom lift without sacrificing the overall quality of pavement, as the bottom lift will not be in direct contact with traffic and environment. Instead, the bottom lift must merely meet structural design strengths. Due to this requirement, 2LCP allows the use of more local and recycled aggregates. In addition, concrete mixture proportions for the bottom lift can be optimized so as to allow lower cement contents, higher SCMs content, and/or higher w/c.

Surface and Ride Improvement

Another benefit of 2LCP is that the design of the top lift can optimize the skid resistance. A common application of modern 2LCP is to provide a relatively quiet, high-friction pavement surface through the use of EAC (Rao 2013). As shown in Figure 6, this application requires the use of extra-hard, wear-resistant aggregates, generally of a smaller than usual size. The use of smaller aggregate requires increased cement content, which increases the cost. These additional costs are usually minor due to the thinness of the top lift and can be offset by savings in the bottom lift, which can use local materials and lower cement contents (Tompkins et al. 2010). While the use of 2LCP can effectively minimize the need for harder (and costly) aggregate to be used in the pavement to provide long-term skid resistance, another important advantage of 2LCP is that the second paver only has to place a limited amount of concrete, so that a higher degree of evenness can be obtained.



Figure 6. Exposed Aggregate Concrete (EAC) (Rasmussen 2008).

Longevity

Since the bottom lift in 2LCP will not be in direct contact with traffic and environment, durability can be improved with the appropriate selection of top lift materials such as optimized ternary mixes, which can effectively reduce permeability, as well as mitigate concerns such as alkali-silica reaction (ASR) and freezing/thawing deterioration. As 2LCP is still relative new, there are very little data available for durability and long-term performance of 2LCP sections. The 2LCP project with the most complete available long-term performance data is the Florida US-41 project, constructed in 1977. More than 5.1 million trucks (6.2 million ESALs) have used the section before the 30-year performance evaluation was done in 2007. Measurements including pavement deflection, load transfer, joint faulting, pavement smoothness, and pavement cracking indicated that most of the 2LCP sections are still in fairly good service conditions after 30 years of service (Greene et al. 2011). The Michigan I-75 project constructed in 1993 also shows 2LCP sections with satisfactory performance after 15 years of service (Smiley 2000). Overall performance of the two-lift pavement section was found to perform better than or equivalent to the control full-depth pavement.

Other Innovative Techniques

2LCP also allows innovative techniques that are not cost effective or technically feasible in traditional single-lift construction to be applied. A 2LCP section with photocatalytic materials in the top layer was recently constructed in Missouri in 2011 on HW-141. The cement used in the top lift was blended with photo-chemically-active titanium dioxide (TiO_2), which is capable of reducing the environmental pollutants from vehicle exhausts (Cackler et al. 2012). Pervious concrete and roller-compacted concrete (RCC) can also be used in the bottom lift, which will further enhance the sustainability of 2LCP.

POTENTIAL CHALLENGES AND CONCERNS OF 2LCP

While benefits of 2LCP are generally recognized, there are some challenges and concerns regarding the implementation of technique. These challenges can be placed in three categories: (1) schedule impacts and additional costs caused by the additional equipment, materials, and quality control practices; (2) need to provide a high quality product that requires quality control, proper construction practices, and on-site control to ensure the accuracy of the paving operations;

and (3) overcoming the reluctance of owners and contractors who have undesirable past experience or perception of 2LCP. The majority of the U.S. contractors concerns are caused by their perception of 2LCP, as there are few who have completed 2LCP projects.

Material Requirements

2LCP requires a consistent and quality effort. While lower quality of concrete and aggregate can be used in bottom lifts, there is no clear guideline for minimum requirements (strength, durability, etc.) for bottom lifts. There is also no clear guideline for characteristic requirements of the materials needed to provide a surface layer (top lift) that meets the future durability, safety, and noise requirements for the public. While there are concerns of if a larger mixing time is required for top lifts, other concerns such as whether the difference of CoTE of the two lifts could have a significant impact on concrete pavement thermal behavior could also affect the pavement design and construction of the two-lift concrete pavement. There is no clear guideline for variability of material characteristics of the materials used in the two lifts, such as a difference in concrete CoTE between lifts to prevent debonding.

Durability

A very limited amount of information is available on the durability of pavement through the 2LCP practice. While most of the test sections (constructed in Florida in 1977 and sections constructed in Michigan in 1993) are still in good condition after up to more than 30 years' service (Greene et al. 2010, 2011; Smiley 2000), there is not sufficient data to support long-term performance of two-lift concrete pavement, particularly with the application of different types of aggregate and amount of supplemental cementitious materials.

Equipment

Figure 7 shows an example of a 2LCP equipment train and site condition. While the practice does not require significant different equipment, 2LCP generally requires additional mixing plants (mixers), paving machines, belt placers, and extra trucks. Besides extra labor for hauling and running the second batch plant (mixer) and placer/spreader, it is generally expected that the construction cost associated with 2LCP is higher than conventional highway paving due to the extra paver/spreader and crew, possibly for a second batch plan and other equipment, permits, and space required for production, and placing of the two mixtures.

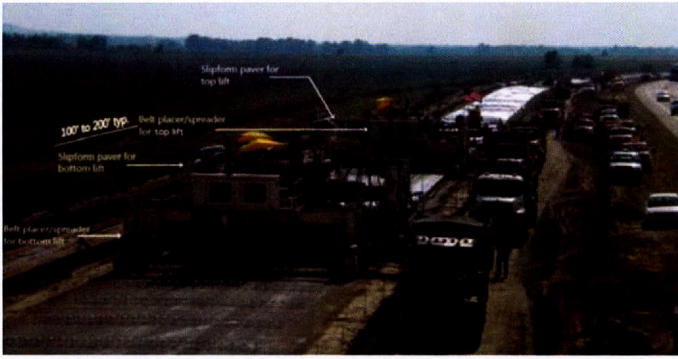

(a) 2LCP with paving train of two pavers (Photo adopted from Fick 2009)



(b) 2LCP with single paver for 2LCP implement (Gomaco 2012)

Figure 7. Construction Operations Involving Two Pavers Assembled as a Train versus a Paver with a 2LCP Implement.

Construction and Scheduling

The 2LCP method requires increased supervision and focus on quality control efforts to ensure the two lifts are placed at the optimum time so that proper bonding of lifts is achieved while consolidation of the bottom lift is not compromised. This method most often requires a second paving operation including equipment and labor that follows at a predetermined distance or time lapse from the placement of the bottom lift. Attention must be paid to the paving rate and distance because the top lift must not be placed until the bottom lift has hardened enough to receive the weight of the top-lift without failure. Likewise, the top lift must be placed while the bottom lift is still wet enough to ensure proper bonding between the two lifts. As shown below in Figure 8, I-30 at Sulphur Springs, constructed in 2LCP practice in 1985, was found to have severe delamination. Even though there is no conclusive evidence to justify the cause(s) of the deterioration, there are concerns of whether possible longer time lag between the two lifts could cause this problem. While the common practice is a 30 to 60 minute time lag between the two lifts, there is no published maximum/optimum time lag to eliminate potential debonding between the two lifts.



**Figure 8. Two-Lift Pavement Delamination on I-30 at Sulphur Springs, TX
(Photo Adopted from Dr. Moon Won).**

The bottom lift should be very stiff in order to sustain action and force on the second lift paving; however, there is no clear definition of stiff. The top lift is generally a higher slump mix, so that the top-lift paver can use a lower vibration rate to achieve a consistent layer (Hooker 2011). Also, there is a need to identify combinations of material and pavement vibrator systems that will minimize the potential for segregation yet still achieve sufficient consolidation and desired surface characteristics. One other unknown is the minimum thickness of the top lift that can practically be constructed and the minimum and/or optimum thickness of the top lift. As the success of 2LCP is greatly determined by equipment/labor arrangement, as well as ambient temperature and humidity conditions, guidelines are also needed for construction site management, including pavers, belt placers, trucks, consolidation, finishing, curing, and jointing practice associated with the construction.

Costs

Cable and Frentress (2004) surveyed American Concrete Pavement Association (ACPA) promoters, engineers, and contractors to determine their views concerning the use of two-lift concrete pavements. While people expressed interest in using different quality concretes for the lower and top lifts, many of them believed that the cost of the two-lift process outweighs the benefit of building an improved top lift. The biggest expense for using two paving plants is the cost of hiring more workers to run the batch plant and second paving machine. The 2LCP would likely result in the use of two concrete plants, two slipform paving machines (although single

machines do exist to perform this operation), and a special haul road, all of which add to a project's cost. While cost of the 2LCP has not been significantly higher in Austria (FHWA 2007a), cost analysis performed on two of the earlier 2LCP projects in the U.S. indicated that the total cost of construction of 2LCP ranged from 30 percent more (Kansas 1997 project) to more than double (Michigan 1994 project) the cost of standard single-lift concrete (Bilec et al. 2010). Both of these projects were demonstration or experimental projects that featured short paving lengths (i.e., too short to take advantage of the economies of scale), unusual contracting aspects, and represented nonstandard practice for the contractor. Therefore, it is unlikely that the costs of these projects accurately represent the probable costs of normally contracted 2LCP projects of sufficient size performed by an experienced contractor.

Other Concerns

Although 2LCP has become a common practice in Europe, and there are some successful examples in the United States, there are still some other general concerns regarding the implementation of the practice. Contractors have expressed concern about the extra permits and land space required to set up the two paving plants that would probably be necessary for a two-lift paving project, further noting that many contractors do not have an extra plant available for use (Cable and Frentress 2004).

As most of the 2LCP projects are jointed plane concrete pavement (JPCP) (or concrete pavement construction design [CPCD]), there are only a few examples of applying the 2LCP concept in CRCP in Belgium and France (Debroux and Dumont 2005; Rens et al. 2008). Although experience indicates that there is no significant difference in applying the 2LCP concept to CRCP compared to CPCD (or JPCP), concerns still exist as to whether there is any additional requirement for CRCP construction and applicability of the 2LCP concept on CRCP. Methods of placement and depth of reinforcement also need to be determined.

CHAPTER 3. CONSTRUCTION PROSPECTIVE OF IMPLEMENTATION OF 2LCP

ADDITIONAL MATERIAL AND PAVEMENT REQUIREMENTS

The research team provided the following recommendations of material requirements for 2LCP construction based on pavement characteristics, aggregate properties, concrete mixture designs that were used in previous 2LCP projects, and other material and pavement considerations collected from the literature review and surveys. Detailed laboratory and model studies are still needed for a successful implementation of 2LCP.

Lift Thickness

Theoretically a thinner top lift is desirable in 2LCP for cost effectiveness purpose; the actual top lift thickness can be determined by many factors, including constructability, aggregate sizes, and considerations for future renewal needs. According to a statistical analysis, most of the top lift thicknesses are between 2 and 3 in. and the bottom layer typically comprises 70 to 90 percent of the total pavement thickness. The average thickness of bottom lift is approximately 7.8 in., with a standard deviation of 1.5 in. The average thickness of the top lift is approximately 2.7 in., with a standard deviation of 0.9 in. Even though a lower thickness can be achieved through the use of smaller size of aggregate, it can be impractical for an appropriate vibration with the further reduction of lift thickness. Records show that with the use of coarse aggregate of a maximum size of as 0.31 in., a top lift thickness of as low as 1.6 in. can be successfully constructed, which is likely the minimum thickness of the top lift that can be practically constructed. Also, with the consideration of future renewal needs to improve ride quality and surface characteristics after a certain period of service, 2 to 3 in. top lift thickness is considered reasonable with the expectation of two to three runs of diamond grinding in the future.

Materials Selection and Mix Proportions

While most coarse aggregates used in the bottom lifts have similar or comparable sizes comparing to conventional concrete pavement, sizes of coarse aggregate used in top lifts are generally smaller, i.e., with sizes of 3/8 in. to 1/2 in. Smaller size aggregates are generally needed for higher quality concrete and/or the requirement to construct thinner top lifts. Another major reason is the need for constructing EAC in the top lift, which is a commonly used practice

in 2LCP. In order to provide a relatively quiet, high-friction pavement surface through the use of exposed aggregate, it is required to use extra-hard, wear-resistant aggregates, usually of a smaller-than-usual size (<1/2-in. top size). The use of smaller size aggregate requires additional cement paste, which increases the cost of the concrete mix, but this impact can be offset by savings in the lower layer in 2LCP construction.

2LCP could improve flexibility in materials selection, particularly regarding to aggregate. While 2LCP allows the use of softer manufactured sand and limestone coarse aggregate in the bottom lift without endangering the wearing resistance of pavement, 2LCP could also allow the use of coarse aggregates that have high CoTE in CRCP. Aggregate blending is possible in 2LCP. CoTE of concrete can be reduced by blending low CoTE aggregate with high CoTE aggregate; abrasion resistant can be improved by blending manufactured sand with natural siliceous sand. There is no known study of potential debonding issues associated with the two different CoTE from the two different lifts. Field and modeling studies show no debonding issues on bonded concrete overlay, which is generally considered to behave similarly to two-lift concrete pavement.

Concrete mix proportions for the bottom lift can be optimized as it will be protected and not be subjected directly to traffic and environment, which means lower cement contents, and/or higher w/c can be used. In addition, a higher SCMs content can be used. A slightly lower cement content of 512 pcy and higher w/c of 0.44 were used in the top lift, whereas a 579 pcy and 0.42 cement content and w/c were used in the bottom lift, respectively.

Materials Characteristics

The average compressive strength of the bottom lift is approximately 4100 psi, which is lower than the top lift at 4600 psi. There is only one project (Florida US41 at 1977) with information of modulus of rupture (MOR), with a 322 to 419 psi at the lower lift and 524 to 755 psi at the top lift.

While there is no specification for characteristics for the bottom and top lift in regarding to opening to either construction traffic or public traffic differ at early ages, the following limits were used in Illinois Tollway construction based on two-lift precast slab load tests performed at the University of Illinois: (a) specimens for both lifts must reach a minimum MOR of 450 psi and a compressive strength of 2,850 psi at an age of no less than 5 days for opening to

construction traffic; and (b) top lift specimens must reach a minimum MOR of 650 psi and a compressive strength of 3,500 psi at an age of no less than 14 days, and bottom lift specimens must reach a minimum MOR of 575 psi and a compressive strength of 3,200 psi at an age of no less than 14 days for opening to public traffic. When strength test results are not available, a 7 days and 28 days curing are also recommended for opening to construction and public traffic, respectively. Experimental and modeling study is needed to determine minimum top and bottom lifts mechanical characteristics (compressive strength and MOR).

Surface Characteristics

After the texture formed on the concrete surface is abraded, the skid resistance of a pavement is a function of the fine aggregate used in the concrete mixture. In a 2LCP, a manufactured fine aggregate could be used in the bottom layer at 100 percent replacement, while a top layer can contain a 100 percent of an aggregate or a combination of two different sands that meets AI requirements. For example, project 0-6255 “Manufactured Sands in Concrete Pavements” indicated that in some cases, as little as 40 percent silica sand along with 60 percent carbonate sand has been found to provided long-term skid resistance. Harder aggregate, including granite, basalt, rhyolite, are used in the top lift in order to provide high skid resistance; more than half of the 2LCP projects use EAC in the top lift to obtain pavement with lower noise level.

Pavement Design

There is no standard pavement design protocol for 2LCP readily available. While most of the 2LCP section were considered as a bonded Portland cement concrete (PCC) overlay over an existing PCC pavement in MEPDG (v. 1.3: R21), the simplification was found to be not self-consistent in its predictions for a newly constructed PCC-PCC pavement (2LCP) and its structurally equivalent single-layer analogue. Modifications to the MEPDG (or DARWin-ME) regarding 2LCP design is currently under development from researchers at University of Minnesota and Applied Research Associations.

ADDITIONAL EQUIPMENT AND CONSTRUCTION REQUIREMENTS

The benefits gained from optimizing materials used for the two lifts will have to be balanced with the additional equipment and construction requirements.

Equipment Requirement

Construction practices for 2LCP have varied during the past decade. At one time, 2LCP pavement was placed at once using one slipform paver; however, this method has been replaced by a train of multiple, independent paving machines. A single paver 2LCP system is available in the market with a two-chamber approach, where both the chambers are fed with concrete and each chamber can lay and compact the concrete independently. As shown in Figure 9, the machine applies an attachment that includes two paving chambers. In this system, dump trucks deliver concrete for the bottom lift directly in front of the machine, an excavator is then used to load concrete for the top lift directly into a hopper that feeds the rear of the machine. This setup eliminates the need to manage the paving rate of two machines and ensures the top lift is placed while the bottom lift is still wet. The attachment also properly consolidates the two lifts along the length of the pavement and along the edges to prevent any mixing of the two concrete mixes.

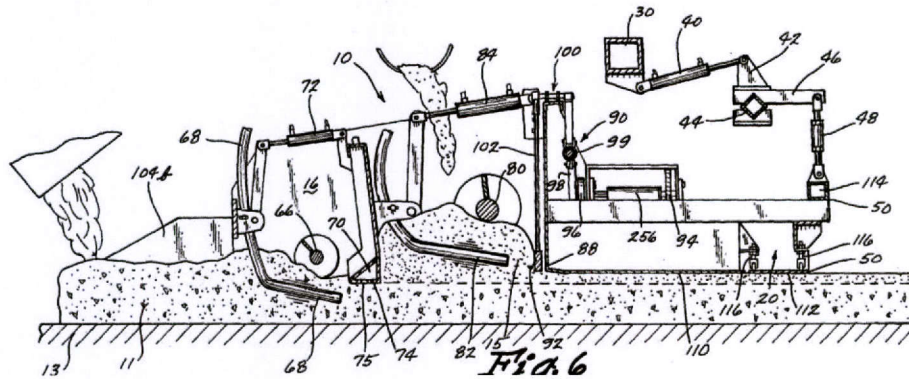
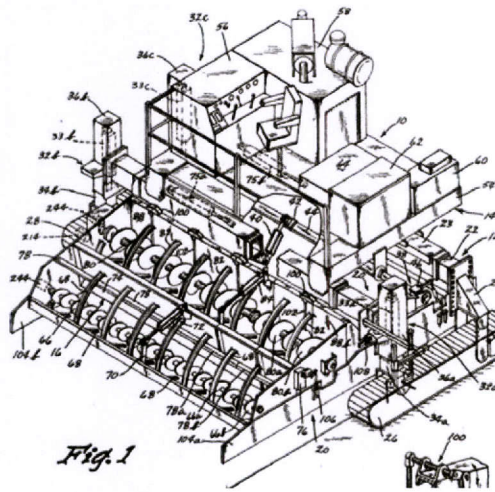

U.S. Patent Feb. 14, 1978

Figure 9. Gomaco GP-4000 Single Paver 2LCP System (Picture from Klein 2013).

The machine was successfully implemented for a 2LCP project near Newport, Wales, in the UK in 1997. The machine design included two paving chambers for the two different layers of material planned for the “EconoCrete” pavement design. However, at that time, cost of producing two mix designs for a single project outweighs savings to be gained by using a lesser quality concrete on the bottom layer. Due to the high cost of paving equipment and attachment, it is believed that the single paver approach might not be cost effective at this time unless a significant amount 2LCP sections are to be constructed and the common practice for 2LCP still uses two pavers. This method is popular in the U.S. for 2LCP construction, mainly because of the lack of 2LCP projects and more construction flexibility.

Mixing and Mix Delivery

While there is generally no explicit description of different (or additional) mixing requirements for the mixtures in the two different lifts, there were cases that a slightly longer mixing time was used in the top lift. During the construction of A6 motorway in Germany, the minimum mix time for the upper layer was 60 seconds and the minimum mix time for the lower layer was 45 seconds. As mixing ensures a uniform distribution of all ingredients in the mixture, a longer mixing time might be needed in the top lift, which often has higher cement content and/or lower w/c.

It is possible to do 2LCP using a single batch plant by using additional aggregate bins present at the single batch plant (enough for all sizes and varieties of aggregate in each of the two mixes). Careful coordination is required to ensure adequate production of both mixtures to avoid disruption (stop and restart) of either paver (particularly the top lift paver), which could result in irregular surface quality and smoothness problems. Color coding was often used to ensure the proper mix was delivered to the spreader placing each lift. Two plants or two mixers operation is used in most of the 2LCP projects constructed in the U.S.

Layer Placement Timing

The spacing (and timing) between the two lifts is one of the most important parameter in 2LCP, because the practice is a wet-on-wet process that requires the two lifts to bond without intermingling. While it is necessary to identify maximum time lag to eliminate potential debonding, project such as Kansas K-96 project in 1997 used a minimum waiting time of 30 minutes in order to prevent mixing of the two lifts. According to information collected from literature review and survey, minimum and maximum time lag between the two lifts were identified as 30 and 90 minutes respective, and a 30-minute time interval is generally considered to be the most preferable. Although none of the 2LCP project included in the study report debonding issues, time lag between the two lifts still remain a major concern, especially during hot weather construction. A retarding agent can be used if debonding is a concern. The bond strength between the top and bottom-lift of concrete is likely directly related to mixture characteristics and weather conditions, such as temperature, relative humidity and wind speed. Further laboratory and field studies might be necessary to determine the minimum bond strength and optimum time lag between the two lifts during 2LCP construction.

Paving Operations

Researchers believe the bottom lift needs to be stiffer (than mixes used in traditional single-lift paving) in order to support the top lift during the 2LCP construction. There is no clear definition of stiff and recommended slump for the bottom lift. Experience from Europe showed that during some 2LCP construction, the bottom lift was extremely stiff with slump of as low as 0.59 in., which might not be practical for construction in the U.S. According to experience in the U.S., most of the bottom lifts used in the U.S. are with slump values between 1 in. and 1.5 in., which is similar to the slump value used in normal slipform paving practice. Statistics analysis confirmed that a slightly lower slump of the bottom lift at an average 1.38 in. (comparing to the 1.60 in. slump of the top lift) is used.

One other consideration during 2LCP construction is to maintain consistent interface, i.e., a level boundary between the two lifts. While European practice appeared to tolerate some variation, some contractors recommended an accelerant in the lower lift to stiffen concrete prior to the second paver pass. As shown in Figure 10, in order to ensure a clean slab edge, a common practice is to have the widths of the bottom lifts slightly (approximately 1.5 in. to 2 in.) smaller than the top lifts. The top lift therefore served as a crown on top of the bottom lift, which minimizes potential issues caused by the unwanted deformation of the bottom during the 2LCP construction.



Figure 10. Envelope Outside Edges of Bottom Lifts (Adopted from Gillen and Vavrik 2012).

As the top lift in 2LCP is much thinner than traditional single-lift pavement, there are concerns on appropriate vibration practices on the top lift so as to have a sufficient consolidation without distributing the bottom lift. While standard poker vibrators may mix the two layers, “T-shaped” vibrators could limit the compaction energy to the top lift only. Also, attentions need to be drawn on vibrator height of the bottom lift to ensure enough clearance between vibrators and dowel or reinforcement. While some contractors stated that they will adjust the vibration frequency and height of vibrators to ensure appropriate vibration, others claim that this is not a major concern during construction.

Surface Preparation

Common practices of finishing and curing that used for traditional single-lift paving are also applied to 2LCP. More than half of the 2LCP projects identified through the study used EAC in the top lift to obtain pavement with lower noise level. The EAC surface is normally constructed by applying a set-retarding agent to the newly placed concrete pavement. After a period of time, the surface mortar is brushed away from the top of the pavement, exposing a surface of durable aggregates. Example of different stages of EAC construction is shown in Figure 11. In EAC construction, proper brushing time is very important, as no water will be

needed during brushing and excess dust will not be generated if the surface is brushed at a proper time.

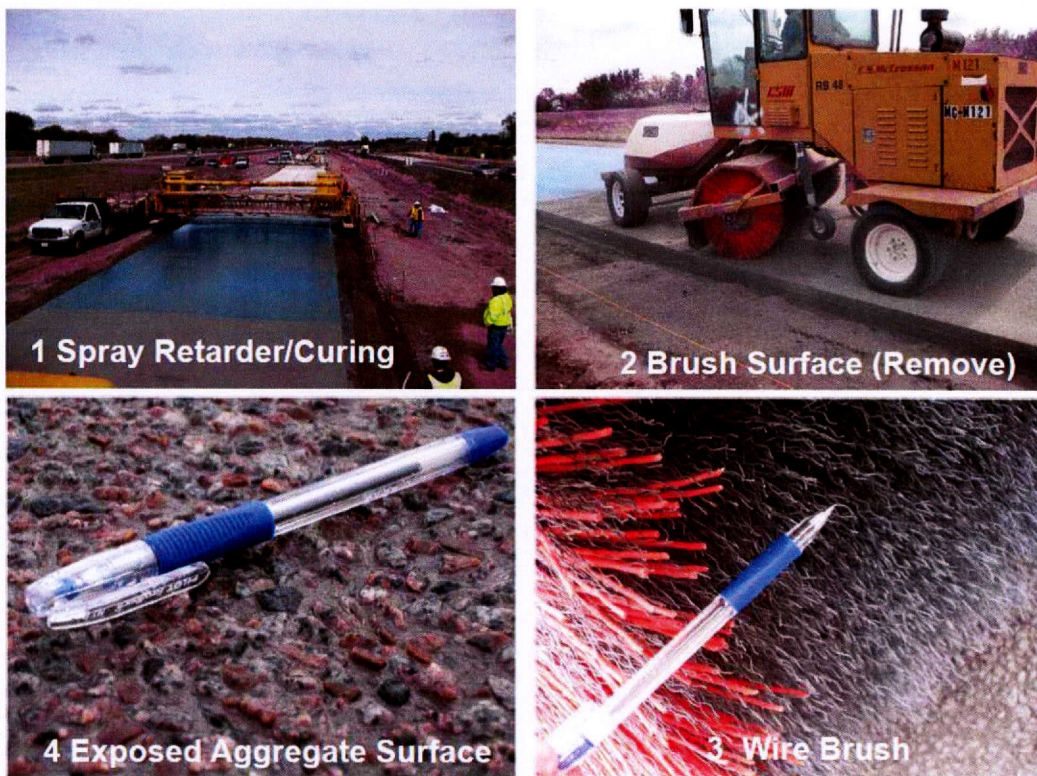

Figure 11. EAC Construction in Minnesota I-95 Project (Rao and Darter 2012).

Reinforcement

Most of the 2LCP are jointed pavement. While there is no CRCP 2LCP has been constructed in the U.S., there are successful CRCP projects (e.g., Belgium N511 2003 and Belgium E34 2005) constructed in 2LCP practice, and no explicated difficulty (comparing to 2LCP in jointed pavement construction) was reported. Challenges to translate experience of jointed 2LCP to CRCP 2LCP can be overcome by more researches and by constructing test sections. Another consideration of using 2LCP concept in CRCP is the placement of two layers of steel, which depends on the thickness of the pavement. If the bottom-lift is thick enough, both layers of reinforcement can be placed in the bottom-lift; otherwise one reinforcement layer has to be placed in the top lift.

IMPACT ON PROJECT SCHEDULING OF IMPLEMENTATION OF 2LCP

Two-lift construction requires a consistent, quality effort. According to the survey conducted through the study, schedule is the major concern and generally considered as the most challenging perspective in a 2LCP construction.

Planning and Scheduling

While benefits of the 2LCP technique are generally recognized, there are some practical challenges and concerns regarding the implementation of the technique. Pre-construction planning and scheduling to obtain additional paver, belt placer, mixer, trucks, and necessary crews is considered to be the most critical factor in a successful 2LCP project. Additional training of the crew and pre-construction meeting is generally recommended for contractors that are not familiar with 2LCP construction. According to Cable and Frentress (2004), many contractors expressed concern about the extra permits and land space required to set up the two paving plants that would probably be necessary for a 2LCP project; some contractors will not even have an extra plant available for use.

Jobsite Management

Since there are two different mixes involved, the 2LCP construction generally requires careful planning during construction and scheduling to manage the construction process. While construction technique is one of the two main areas of emphasis in European paving practice, construction scheduling and planning is considered a major challenge to adoption of the 2LCP concept in the U.S. 2LCP involves additional mixing plants, paving machines, belt placer, and extra trucks to handle the two different mixtures, and additional site scheduling is needed to manage the implementation of 2LCP.

While it is important for all slip-form paving operations, consistent delivery of uniform concrete could be even more critical for the construction of two-lift pavement. The upper layer might require a larger mixing time compared to the lower layer. Additionally, the width and alignment of the two pavers placing the two lifts requires special attention. In order to ensure smooth operation during 2LCP construction, a well-organized construction site and well trained crew is needed. The 2LCP is best suited for large paving projects that require high production quantities, such as interstate sections or airport pavements.

CHAPTER 4. COST EFFECTIVENESS OF 2LCP

GENERAL COST PERSPECTIVES OF 2LCP

Aggregate costs have increased greatly in recent years and this trend is expected to continue. Much of the increase in costs is due to increases in energy costs required for production and transportation. However, there are some price increases due to local supply/demand issues for certain types and classes of aggregate as well. There is also an expectation of additional cost due to increased industry (specifically environmental-related) regulation. The concrete industry believes that the days of having virtually unlimited supplies of Class A aggregate (for concrete paving mixtures) are behind us. Many of the best sources of this material have been depleted, resulting in local shortages of supply. These shortages might be alleviated (at least in part) by adopting two-lift concrete pavement construction techniques where Class A aggregate is used in a relatively thin surface lift while marginally acceptable aggregate (e.g., soft manufacturing sand, siliceous gravel with high CoTE, recycled concrete aggregate, or other sources) is used in the thicker lower lift (Bilec et al. 2010).

In 2LCP practice, the bottom layer typically comprises 80 to 90 percent of the total pavement thickness and generally contains locally available aggregates that are typically obtained at a lower cost than aggregates used in a traditional paving project. Also, since the bottom lift is usually subjected to less environmental exposure, a lower quality concrete with lower cement content and higher SCMs can be used without sacrificing the durability of the pavement system, which can significantly reduce the cost of concrete mixtures used in the lower lift. While the top lift concrete is generally relatively expensive because of the smaller size aggregate and higher cement content, and usually contains higher quality aggregates that are often imported and more expensive, their impact on the overall pavements system cost is usually low because of the relatively small quantities that are required. Even though there are no data available from existing 2LCP projects, potential materials saving in pavements that traditionally require higher thicknesses (such as airport pavements) could potentially benefit more from 2LCP concept due to the lower top lift over bottom lift thickness ratio.

With a complex process such as 2LCP, cost of uncertainty and risk could be significantly higher as the process relies on multiple in series processes that all depend on each other and all have individual uncertainty. According to results from Survey A conducted by the research team, several contractors (8 percent of the respondents) stated that unexpected expenditures could have

the greatest impact to overall 2LCP project cost. Due to the extra paver or spreader and crew and possibly for a second batch plant and other equipment, permits and space required for production of two mixtures, the construction cost associated with 2LCP is generally higher than conventional single-lift concrete paving. In addition, the increase of crew size and reduced production rate also results in additional costs associated with 2LCP. Compared to conventional highway paving, there was some loss of production speed due to the introduction of the second set of pavers; however, the loss was not as much as expected (Hooker 2011). While it is likely that there are significant added expenses with two-lift paving due to the extra paver or spreader and crew and possibly for a second batch plant and other equipment, permits and space required for production of two mixtures, these added costs may be partially or wholly offset by increase in productivity, the ability to use recycled or other lower-cost materials in the lower lift, and by longer pavement life of a smoother ride equality and better skid resistance.

The 2LCP system could also have a reduced life-cycle cost compared to an equivalent single-layer system because of the possible improved structure performance and the reduced maintenance and rehabilitation needs associated with the improved durability and surface texture with a smoother ride equality and better skid resistance. A life cycle analysis (LCA) of the Kansas I-70 project in 2008 indicated that there is a 15 percent reduction of global warming potential when 2LCP is used compared to traditional paving. In terms of energy, a 20 percent reduction can also be observed when using 2LCP (Meijer 2008). Although data are not available at this time, a life cycle cost analysis incorporating all above mentioned benefits would be helpful to justify the long-term cost effectiveness of 2LCP.

COST INFORMATION FROM PREVIOUS 2LCP PROJECTS

Most of the 2LCP projects have been conducted in Europe and may not provide accurate information regarding the US market; the few projects conducted in the U.S. have been mostly demonstration or experimental projects, and the relative small sizes of the projects might not represent typical pavement projects. Following sections present a summary of cost information from selected 2LCP projects recently constructed. Detailed cost information can be found in case studies of specific projects presented in Appendix A.

According to information from the MnRoad I-94 project in 2010, the paving cost almost doubled due to the additional equipment and crew. Comparing to conventional concrete paving

process, the crew size increased from 13 to 18, which increased the cost by approximately \$9,000/day to \$15,000/day. Compared to conventional highway paving, there was some loss of production speed due to the introduction of the second set of paver; however, the loss was not as much as expected (Hooker 2011). The project also showed a reduced production rate from 27 paving days to 34 paving days (Krummen 2012).

Costs of the extra paver or spreader and crew and possibly for a second batch plant and other equipment, permits and space required for production of two mixtures may be partially or wholly offset by the ability to use recycled or other lower-cost materials in the lower lift. According to information collected from the study, a few early 2LCP projects conducted in the U.S. showed the total cost of construction of 2LCP ranged from 30 percent more (Kansas 1997 project [Wojakowaski 1998]) to more than double (Michigan 1993 project [Buch et al. 2000]) the cost of standard single-lift concrete, which is likely due to the nature of demonstration or experimental projects that featured short paving lengths (i.e., too short to take advantage of the economies of scale), unusual contracting aspects, and nonstandard practice for the contractor.

Table 4. Cost Comparisons from Selected 2LCP Projects.

	Pavement Type	Thickness	Concrete Cost	Paving Cost	Total Cost
Michigan 1993	Conventional	11"	-	-	\$37.58/sy
	2LCP	2.5"+7.5"	-	-	\$87.76/sy
Kansas 2008	Standard	12"	\$57/cy	\$99/cy	\$33/sy
	Durable	12"	\$102/cy	\$144/cy	\$48/sy
	2LCP	2"+10"	\$64.5/cy	\$122/cy	\$41/sy
Minnesota 2010	Conventional	9"	\$71.07/cy	\$2.61/sy	\$20.38/sy
	2LCP	3"+6"	\$62.66/cy	\$4.28/sy	\$19.94/sy
Illinois 2012	Conventional	12"	-	-	\$65.00/sy
	2LCP	3.5"+8"	-	-	\$45.92/sy

However, as shown in Table 4, recent projects in Kansas 2008 (Howard 2009), MnRoad 2010 (Krummen 2012), and Illinois Tollway (Rao 2013) all showed lower total cost with the adoption of 2LCP. The positive data are due to the substantial saving from the reduced aggregate costs and concrete cost used in the bottom lift, together with the positive bidding climate currently seen in the U.S. The observation is confirmed with experiences in Europe that the cost of the 2LCP is not necessarily higher compared to conventional concrete paving.

COST ANALYSIS

As costs of implementing this new 2LCP might be significantly different due to the location and size of projects, researchers performed a case-based cost analysis to evaluate potential cost benefit in selected districts that facing aggregate shortage issues. These case studies serve as examples to justify cost effectiveness of implementing the 2LCP concept. Pavement concrete with good quality exported coarse aggregates was considered for the CRCP and the top-lift of 2LCP. Locally available high CoTE coarse aggregates were considered for 2LCP bottom-lift. Other design parameters were considered same for 2LCP and CRCP. Previous studies showed that 2LCP labor and equipment costs increased by 20 to 60 percent due to additional labor and equipment use (Wojakowski 1998; Buch et al. 2000). To simulate the effect of additional labor and equipment requirement for the 2LCP, labor and equipment costs were assumed to increase by 25 percent and 50 percent. Since the material for the top lift of the 2LCP and the CRCP were considered same, these pavements would likely to exhibit similar field performance, and the maintenance cost would be similar. Therefore, the maintenance cost was not included in this study. Houston and Paris Districts were selected to conduct the cost analysis. Material costs were obtained and cost analysis method was adopted from TxDOT project 0-6681 “Optimizing Concrete Pavement Type Based on Aggregate Availability.”

For Houston and Paris Districts, FOB cost of locally available coarse aggregates were \$13.00 and \$12.00/ton, distance of the quarry from the job site was considered as 20 and 40 miles, respectively. For both the districts imported limestone FOB cost was considered \$7.55/ton and distance of quarry from the job site for Houston and Paris Districts were considered as 200 and 150 miles, respectively. Transportation cost was considered as \$0.17/ton/mile for all case. Concrete cost excluding coarse aggregate was considered \$45.00/yd³ for normal concrete and \$36.00/yd³ for lean concrete. Costs for one lane mile of pavement are presented in this section.

Figure 12 shows the comparison of total construction costs of 12-in. CRCP and 2LCP at varying top-lift (TL) thickness. Top-lift thickness of 2LCP was varied from 2 to 3.5-in. at 1/2-in. increments. Total construction cost was considered as the sum of construction and material cost. Total construction cost of 2LCP is higher than the CRCP for both the Houston and Paris Districts, while labor and equipment cost was considered 50 percent higher for 2LCP. For 25 percent increase in labor and equipment cost, 2LCP cost in the Houston District is lower, and

for the Paris District the total cost of 2LCP is slightly higher than the CRCP. The Houston District has higher transportation costs for imported aggregate than the Paris District, hence economic significance of 2LCP is more substantial for Houston than Paris.

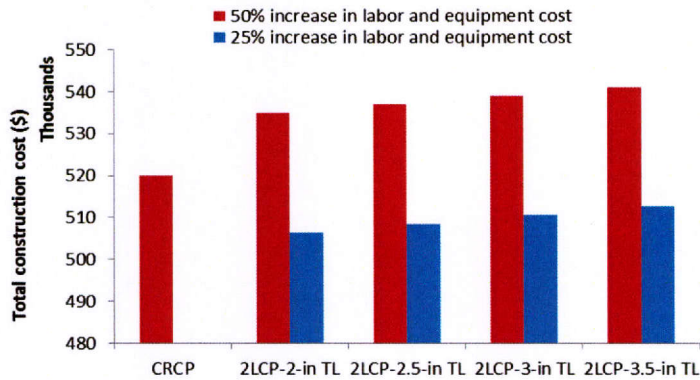

(a) Houston District

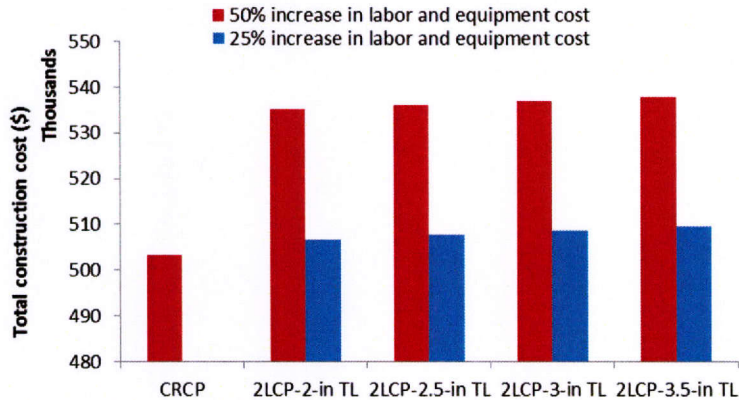

(b) Paris District

Figure 12. Comparison of Total Construction Cost for 12-in. CRCP and 2LCP for Varying Top-Lift (TL) Thickness.

Figure 13 shows separate material and construction costs for the Houston and Paris Districts for 12-in. thick pavement. Material cost is the largest portion of total construction cost.

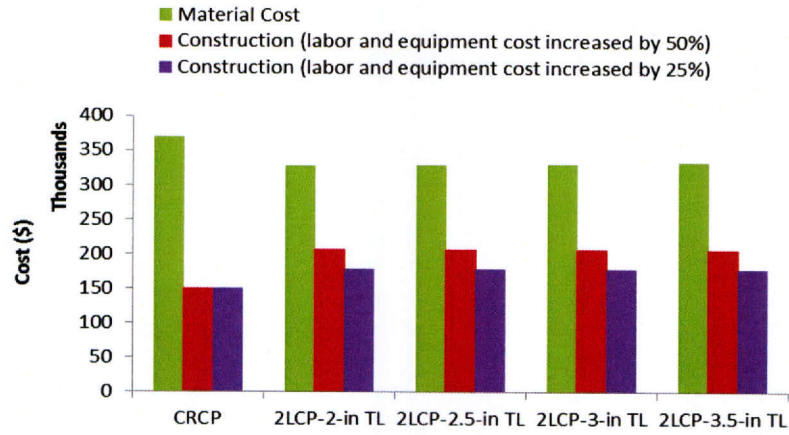

(a) Houston District

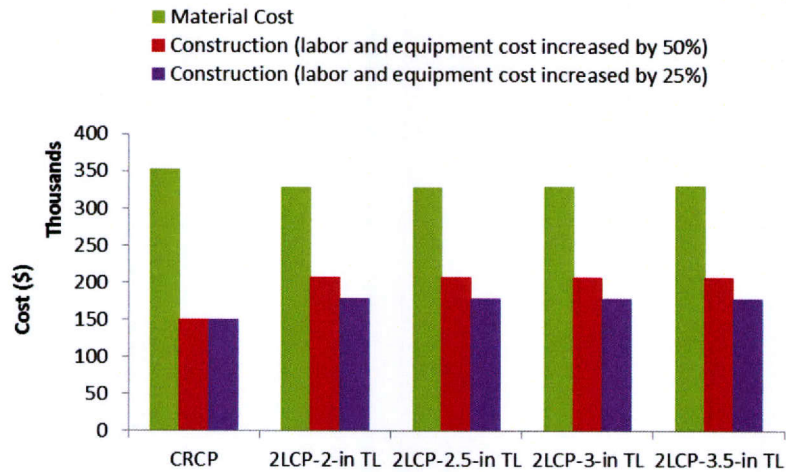

(b) Paris District

Figure 13. Material and Construction Cost of 12-in. Concrete Pavement.

Figure 14 shows the comparison of total costs of CRCP and 2LCP pavement for varying top-lift thickness. Lean concrete was considered for the bottom lift. 2LCP was an economical choice for both the Houston and Paris Districts, while labor and equipment costs were increased by 25 percent. For a 50 percent increase in labor and equipment costs, total cost of 2LCP in the Houston District is very close to the CRCP.

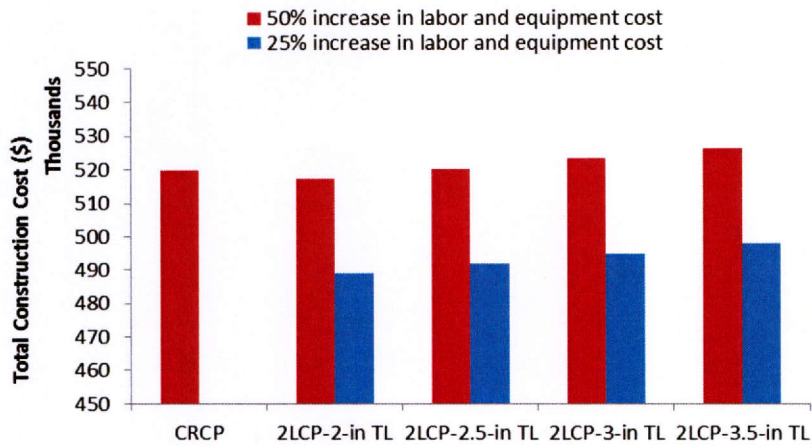

(a) Houston District

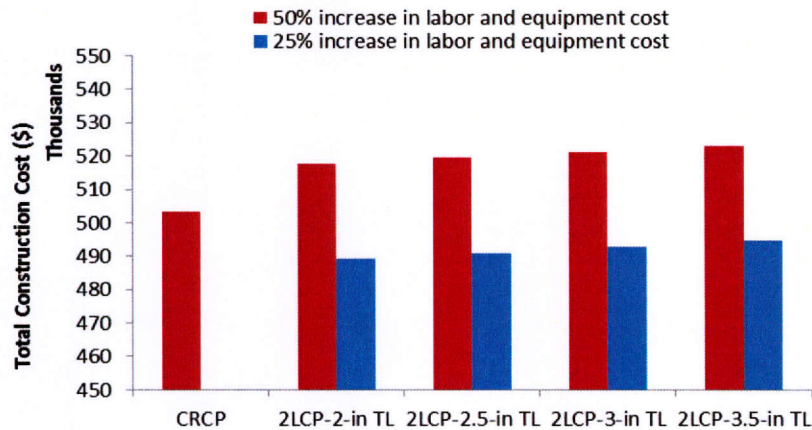

(b) Paris District

Figure 14. Comparison of Total Construction Cost for 12-in. CRCP and 2LCP, Lean Concrete at the Bottom-Lift.

Figure 15 shows that the effect of pavement thickness on the total construction cost of CRCP and 2LCP. Top-lift of the 2LCP was considered to be 2.5-in thick. Ten, 12, and 14-in. pavement thicknesses were considered. Top and bottom lifts considered were normal concrete. The total cost of 2LCP construction is found to be higher than CRCP with a 50 percent increase in labor and equipment, but lower with a 25 percent increase, except for 10 and 12-in. pavement in Paris District.

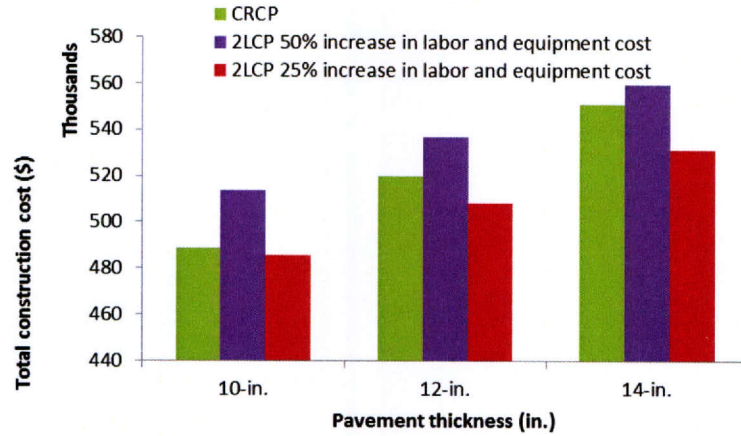

(a) Houston District

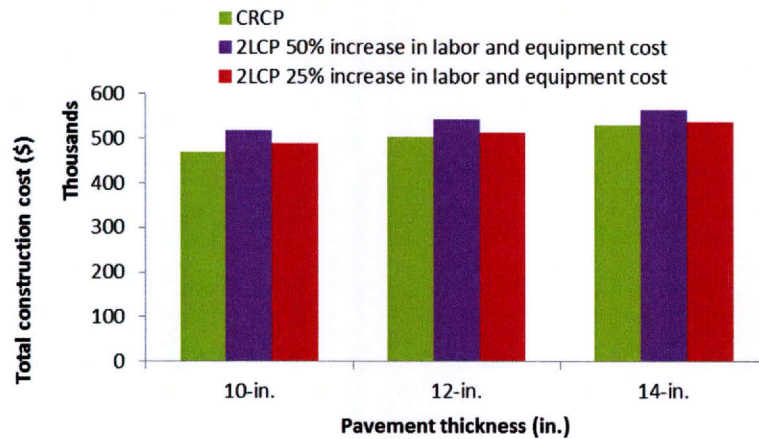

(b) Paris District

Figure 15. Effect of Pavement Thickness on the Total Construction Cost of CRCP and 2LCP.

Although no study was conducted to evaluate cost effectiveness from adopting 2LCP concept in locations such as the Dallas or Fort Worth Districts with the use of local manufactured sand versus imported siliceous sand, researchers expect similar results. Case-based cost analysis showed that 2LCP can be an economical choice over CRCP for locations where there are no good quality aggregate sources available in the vicinity. Use of lean concrete in the lower lift can

also reduce the total initial construction cost. Thinner top lift and increase in total pavement thickness reduces the construction cost.

CHAPTER 5. BEST PRACTICES OF 2LCP

FEASIBILITY OF 2LCP

The learning process of constructing 2LCP and lack of specifications are the two major reasons that hinder the implementation of 2LCP in the U.S. Previous experiences indicated that 2LCP can be a feasible alternative from both technical and cost perspectives. The 2LCP can become a promising alternative in situations such as when high SCMs or low cement content mixes, surface durability and rapid renewal (for low pavement noise or high friction) conditions, or high durable pavements are desired. The 2LCP can also become a cost effective (either current or long term) alternative when high-quality aggregates for PCC are not available (quality aggregates are scarce), recycling and sustainability are important considerations, or situations that traditionally require higher volumes or higher thicknesses, such as airport pavements.

CONSIDERATIONS FOR PAVEMENT TYPE SELECTION

To determine whether a 2LCP practice should be applied could be a complicate situation as considerations from technical, economical and construction prospective could all impact the final decision. Material properties are one of the important factors for the durability of concrete pavement. As some parts of Texas do not have suitable aggregate sources for concrete pavement in the vicinity, to construct durable concrete pavement, suitable aggregates have to be transported from a longer distance. Additional transportation costs will increase the total project cost. 2LCP requires good quality materials in the thinner top lift and inferior quality materials can be used in the bottom lift, which can be economical over traditional single-lift paving for locations where good quality aggregate sources are not locally available. However, the labor and equipment costs for the 2LCP construction are higher.

Technical feasibility of 2LCP is determined by many aspects, including type, characteristics, hauling distance and costs of local aggregate, size of project, experience, and capability of contractors. Successful implementation of the 2LCP involves a good understanding of 2LCP system, scheduling, and site management. Figure 16 shows a flow chart incorporating considerations including materials, costs, and constructions. The flowchart provides TxDOT engineers a recommended best practice protocol for implementing a 2LCP construction.

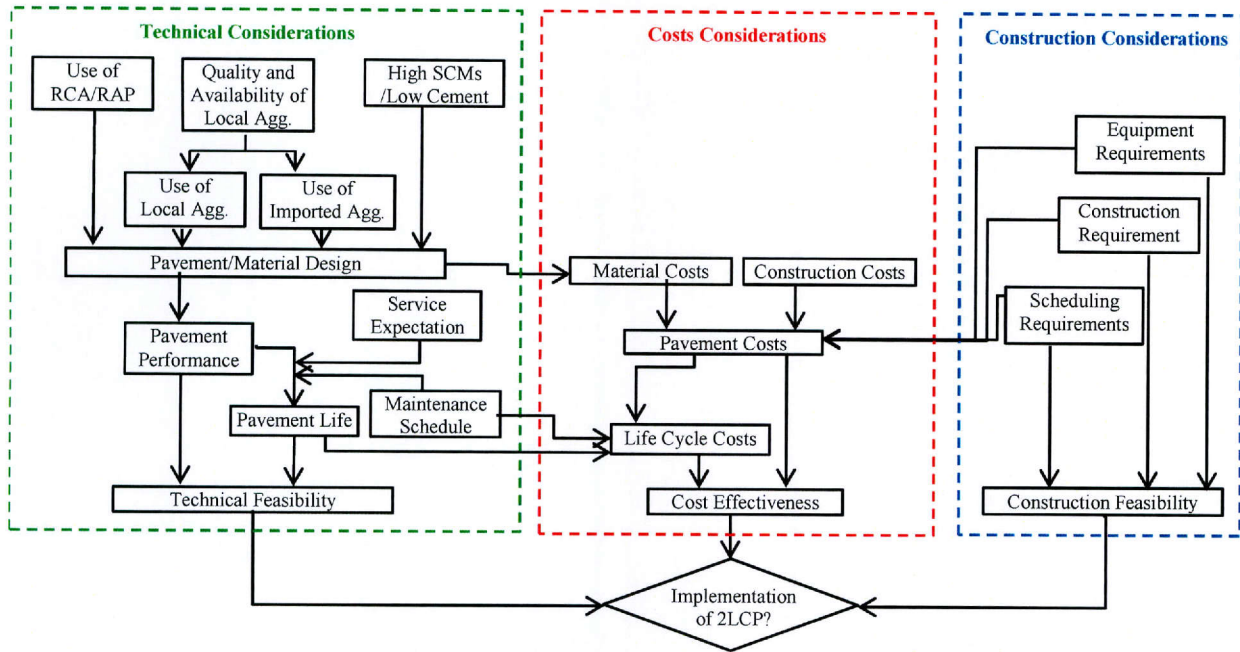

Figure 16. Framework of a Flow Chart for 2LCP Decision.

RECOMMENDED PRACTICES FOR 2LCP IMPLEMENTATION

The following material requirements and construction practices as shown in Table 5 can be recommended for the implementation of 2LCP.

Table 5. Recommend Practices for 2LCP Implementation.

	Considerations	Recommended Practices
Materials	Lift Thickness	2 to 3" for cost effectiveness and practical construction of the top lift.
	Material Selection and Mix Proportions	Smaller size of coarse aggregate and harder coarse and fine aggregates are normally used in the top lift. Locally available low quality aggregate, RCA and RAP, blended aggregate (with high CoTE), high SCMs contents, and low cement content is possible for the bottom lift.
	Materials Characteristics	Experimental and modeling study is needed to determine minimum top and bottom lift mechanical characteristics (compressive strength and MOR).
	Durability	Limited data show satisfactorily long-term performance.
	Pavement Design	Currently using bonded PCC overlay of an existing PCC pavement.
Equipment and Construction	Equipment Requirement	A second mixing plant (or a second mixer with additional aggregate bins), a second paving machine, belt placer/spreader, and additional trucks for two different mixtures are needed.
	Mixing and Mix Delivery	No explicit difference of mixing time expected, but slightly longer mixing time could be required for upper lift (depends on the mixture). Consistent delivery of uniform concrete is critical. Color code or different concrete trucks to distinguish different concrete.
	Layer Placement Timing	Generally between 30 to 60 minutes, depending on weather conditions. Retarding agents can be used if debonding is a concern. Study is needed to determine the minimum bond strength and optimum time lag between the two lifts during 2LCP construction.
	Paving Operation	Slightly stiffer bottom lift (1 to 1.5" slump) to support top lift placement. Width and alignment of the two pavers requires special attention. A slightly narrower bottom lift is commonly used to ensure clean slab edge. Appropriate consolidation practice is needed to ensure sufficient consolidation and no disruption of the bottom lift.
	Surface Preparation	No explicated difference compared to traditional single-lift paving practice. Need to follow EAC practice if applies.
	Reinforcement	No additional requirement for CRCP.
Project Scheduling	Planning and Scheduling	Extra labor is needed to run the second mixing plant, paving machine, and trucks. Additional training and a pre-construction meeting are recommended.
	Jobsite Management	Well-organized jobsite and scheduling of operating additional mixing plant, paving machine, and trucks are needed.

CHAPTER 6. CONCLUSIONS AND RECOMMENDATIONS

CONCLUSIONS

Two-lift concrete paving involves placing two layers of concrete (wet-on-wet) instead of a single homogeneous layer, as is typically done in the United States. Since sustainability is becoming increasingly important in concrete paving, 2LCP is an effective tool to address economic and environmental challenges.

A comprehensive literature review was conducted to gather previous experiences and past performances of 2LCP, particularly to justify the cost and efficiently execute the process of 2LCP. Surveys and interviews were conducted to determine experiences of contractors and agencies with 2LCP and to determine TxDOT personnel's concerns on implementation of 2LCP. A one-day workshop regarding 2LCP was organized for a wide range of agency, construction, equipment people, and TxDOT personnel with experience or interests in 2LCP. The workshop also served as a solicitation of ideas of the best practice, most cost effective approach, concerns, and requirements associated with materials and construction of 2LCP. Information and inputs collected from literature reviews, surveys, interviews and the 2LCP workshop were summarized to provide construction perspectives of implementation of 2LCP, including additional costs, requirements and impacts to project scheduling of implementation of this concept. The extensive summary based on recent experiences in Europe and the U.S. provides specific guidelines and recommendations that could be helpful in the implementation of 2LCP construction. Researchers concluded the following:

1. 2LCP opens up opportunities not only to use local and/or recycled materials that in the past have not been suitable for concrete pavements, but also to incorporate surface techniques to address the noise and safety challenges and public demands. Districts including Houston, Fort Worth, and Dallas have the potential to receive great benefit from the concept by being able to use more locally available materials that is not considered appropriate for traditional (single lift) concrete pavement use.
2. Challenges of 2LCP include having the proper paving equipment and pavement construction management, the right mixture proportions to ensure the use of local materials in the bottom

lift to result in an economical placement, and the proper proportions and materials to ensure adequate surface friction in the top lift.

3. A case-based cost analysis showed that while 2LCP does result in increased construction costs associated with additional equipment, labor and scheduling effort, savings from the use of lower-quality, less expensive concrete and aggregate in the bottom lift could be sufficient to offset the additional costs.
4. Case studies of recently constructed projects showed that 2LCP projects can be a viable alternative from both sustainability and economics. The decision of whether to adopt 2LCP is determined by technical, economic, and construction considerations.

RECOMMENDATIONS FOR FUTURE RESEARCHES

The following recommendations can be made:

1. Since 2LCP is becoming a technical and economically feasible technique, more demonstration projects are needed to promote the practice and resolve difficulties and challenges for 2LCP implementation. Demonstration projects on a limited paving section that is part of an ongoing paving could be contracted to demonstrate the feasibility of 2LCP. An implementation program with paving sections that include variables of materials/thickness in both lower and upper lift is needed.
2. As the technique is still relatively new, it is important to increase the public awareness of the 2LCP. Researchers developed a blog (Hu and Fowler 2013) with the project that includes workshop presentations and summary of the 2LCP workshop, which could serve as a platform for discussion as well as information sharing. Presentations regarding technical and economical perspectives of 2LCP as well as construction practices from different TxDOT districts could also be helpful.
3. Laboratory and field studies to determine optimum time lag between the two lifts under different conditions, minimum bond strength, and CoTE on debonding issues and/or thermal deformation are also needed.
4. Other applications such as RCC in the bottom lift and/or pervious concrete in the top lift can also be studied to explore additional environmental and economic benefits of 2LCP.

REFERENCES

- Akkari A., and Izevbekhai B., Composite Pavements at MnRoad: Cells 70, 71 and 72 Construction Report and Early Performance Evaluation, Minnesota Department of Transportation, 2011.
- Bilec M. M., Marriott J., Padilla M. F., and Snyder M., Market Analysis of Construction Materials with Recommendations for the Future of the Industry, Pennsylvania Department of Transportation, Report FHWA-PA-2010-004-PIT016, 2010.
- Buch N., Lyles R., and Becker L., Cost Effectiveness of European Demonstration Project: I-75 Detroit, Michigan Department of Transportation, Report RC-1381, Lansing, Michigan, 2000.
- Cable J. K. and Frentress D. P., Two Lift Portland Cement Concrete Pavements to Meet Public Needs, FHWA Report DTF61-01-X-00042 (Project 8), Center for Transportation Research and Education, Ames, Iowa, 2004.
- Cackler, T., Alleman J., Kevern J., and Sikkema J., Technology Demonstrations Project: Environmental Impact Benefits with “TX Active” Concrete Pavement in Missouri DOT Two-Lift Highway Construction Demonstration, FHWA Report DTFH61-06-H-00011 Work Plan 22, National Concrete Pavement Technology Center, Ames, Iowa, 2012.
- Cackler T., Video Conference Agenda and Meetings Notes: Two-Lift Concrete Pavements, FHWA IA Division Office, June 2007.
- Castecker C., Test Sections of Noiseless Cement Concrete Pavements. Routes/Roads, 1998.
- Ciggelakis W., Van Delist S., and Taubert D. H., A Place in History, PSI, 2013.
- Cole, L. W., Observations from the U.S. Tour of European Concrete Highways (USTECH) - Summary of the USTECH Report, 1995.
- CP Road Map, Two-Lift Concrete Paving, Map Brief 13-1, 2010.
- Darter M. I., Report on the 1992 U.S. Tour of European Concrete Highways, FHWA-SA-93-02, Federal Highway Administration, Washington D.C., USA, 1993.
- Debroux R. and Dumont R., Twin-Layer Continuously Reinforced Concrete Pavement on the N511 at Estaimpuis (Belgium): An Investigation of the Optimization of Surface Characteristics, 8th International Conference on Concrete Pavements, Colorado Springs, Colorado, USA, August 14-18, 2005.
- Fick G., National Open House Two-Lift Concrete Paving October 15-16, 2008, Saline/Abilene, KS - Interstate 70, National CP Tech Center, 2009.
- FHWA, Take a Look at Two-Lift Concrete Paving, Focus, August 2007a.

- FHWA, Innovator - Accelerating Innovation for the American Driving Experience, vol. 1, Issue 4, FHWA-HIF-07-023, December 2007b.
- FHWA, Long-Life Concrete Pavements in Europe and Canada, FHWA-PL-07-027, 2007c.
- FHWA, Report on the 1992 U.S. Tour of European Concrete Highways, Testing and Research Section Construction and Technology Division, Research Report No. RC-1464, 1992.
- Fick G., National Open House Two-Lift Concrete Paving October 15-16, 2008, Saline/Abilene, KS - Interstate 70, National CP Tech Center Report, 2009.
- Flintsch G. W., Diefenderfer B. K., and Nunez O., Composite Pavement Systems: Synthesis of Design and Construction Practices, Virginia Transportation Research Council, VTRC 09-CR2, 2008.
- Gillen S. L. and Vavrik W. R., Illinois Tollway's Concrete Sustainability Research & Implementation, ACPA National Conference, Las Vegas, NV, November 30, 2013.
- Gomaco, Introducing a New Slipforming System to the Czech Republic, http://www.gomaco.com/Resources/worldstories/world35_2/skanska. July 2007, Accessed October 2012.
- Greene J., Nazef, A. and Choubane B., Thirty-Year Performance Evaluation of Two-Layer Concrete Pavement System, Transportation Research Record, Vol. 2226, 2011, pp. 21-29.
- Greene J., Nazef A., and Choubane B., A 30-Year Performance Evaluation of a Two-Layer Concrete Pavement System, Florida Department of Transportation, FL/DOT/SMO/10-540, 2010.
- Gray J.E. and Renninger F.A., The Skid Resistant Properties of Carbonate Aggregate, 44th Highway Research Board Annual Meeting, January 1965.
- Grove J., Vanikar S., and Wathne L., Sustainability Opportunities for Concrete Pavements, Indian Concrete Journal, v 85, n 3, p 7-15, March 2011.
- Grove J., and Taylor P., Two-Lift Construction to Address Today's Challenges, 11th International Symposium on Concrete Roads, Seville, Spain, October 2010.
- Hall K., Dawood D., Vanikar S., Tally R. Jr., Cackler T., Correa A., Deem P., Duit J., Geary G., Gisi A., Hanna A., Kosmatka S., Rasmussen R., Tayabji S., and Voigt G., Long-Life Concrete Pavements in Europe and Canada, FHWA-PL-07-027, 2007.
- Hooker K. A., How About a (Second) Lift?, Concrete Construction, 2011, pp. 20-24.
- Howard D., Two-Lift Construction Update 100% Recycled Concrete Aggregate, 46th Annual ACPA Conference, Orlando, Florida, December 4, 2009.

- Hu J., and Fowler D., Two-Lift Paving Workshop, May 23rd, 2013.
<http://blogs.utexas.edu/ctr/2013/07/18/2lcp-workshop/>. Accessed July 26th, 2013.
- Klein K., Two-Lift Concrete Paving: Equipment Perspective, Two-Lift Concrete Paving Workshop, Austin, Texas, May 23, 2013.
- Kreen, H. and Stinglhammer H., New from Old - Recycling Concrete Pavements. 7th International Symposium of Concrete Roads, Vienna, Austria, 1994.
- Krummen S., Constructing a Composite Pavement from Subgrade Up, Transportation Research Board 91st Annual Meeting, 12-6264, Washington D.C., January 22-26, 2012.
- Kuennen, T., Roadbuilders to Get Fresh Look at Two-Lift Concrete Paving, Better Roads, 2008, pp. 22-29.
- Meijer J., Environmental Benefits of Two-Lift Pavement: A Quantitative Perspective Based on Life Cycle Assessment (LCA), 2008 National Two-Lift Paving Open House, Salina and Abilene, Kansas, October 15-16, 2008.
- Rached M., Fowler D., and Whitney D., Preliminary Guidelines for Proportioning Class P Concrete Containing Manufactured Fine Aggregates, Texas Department of Transportation, Project 0-6255, October 2010.
- Rao, S., Darter M., Tompkins D., Vancura M., Khazanovich L., Signore J., Coleri E., Wu R., Harvey J., and Vandebossche J., Composite Pavement Systems Volume 2 PCC/PCC Composite Pavements, Publication SHARP 2 Report S2-R21-RR-3. Transportation Research Board, Washington, D.C., 2013.
- Rao S., Two Lift Composite Pavements, Two-Lift Concrete Paving Workshop, Austin, Texas, May 23, 2013.
- Rao S., and Darter M.I., Composite Pavement Systems – A Sustainable Approach for Long-Lasting Concrete Pavements, 10th International Conference on Concrete Pavements, 2012.
- Rasmussen R., Surface Characteristics Site Report (Site 349-1), National Concrete Pavement Technology Center Report, Ames, Iowa, 2008.
- Rens, L. Two-lift Paving Design Aspects. Austin, TX, May 23, 2013.
- Rens L., Keymeulen H., and Van Wijndaele I., A Double-Layered CRCP: Experiences on the E34 Near Antwerp (Belgium), 9th International Conference on Concrete Pavements, San Francisco, California, August 17-21, 2008.
- Shields-Cook S. and Taylor P.C., Working a Double Lift, Roads & Bridges, Vol. 47, 2009, pp. 32-35.

- Smiley D. L., Fifteen Year Performance Review of Michigan's European Concrete Pavement. Michigan Department of Transportation, 2010.
- Smiley D.L., Fifteen year Performance Review of Michigan's European Concrete Pavement, Michigan Department of Transportation, Report R-1538, Lansing, Michigan, 2000.
- Smiley D. L., Second Year Performance of the European Concrete Pavement on Northbound I-75-Detroit, Michigan. 1996.
- Snell L. H., and Snell B. G., Oldest Concrete Street in the United States, Concrete International, American Concrete Institute, 2002, pp. 52-74.
- Taylor P., Two Lift Paving: An Overview, Two-Lift Concrete Paving Workshop, Austin, Texas, May 23, 2013.
- Taylor P., Two-Lift Concrete Pavement Construction, Proceedings of the 2009 Mid-Continent Transportation Research Symposium, Ames, Iowa, August 2009.
- Tompkins D., Khazanovich L., Vancura M., Darter M. I., and Rao S., Construction of Sustainable Pavements: Two-Layer Concrete Pavements at the MnRoad Facility, Transportation Research Board 90th Annual Meeting, 11-0769, Washington D.C., January 23-27, 2011.
- Tompkins D., Khazanovich L., and Darter M. I., 2008 Survey of European Composite Pavements, SHRP 2 Renewal Research, SHRP 2 Report S2-R21-RW-1, Transportation Research Board, Washington D.C., 2010.
- Tompkins D., Khazanovich L., Darter M. I., and Fleischer W., Design and Construction of Sustainable Pavements, Austrian and German Two-Layer Concrete Pavements, Transportation Research Record, Vol. 2098, 2009, pp. 75-85.
- Van Dam T., Taylor P., Fick G., Gress D., VanGeem M., and Lorenz E., Sustainable Concrete Pavements: A Manual of Practice, FHWA DTFH61-06-H-00011 (Work Plan 23), National Concrete Pavement Technology Center, Ames, Iowa, 2011.
- Vancura M., Khazanovich L., and Tompkins D., Reappraisal of Recycled Concrete Aggregate as Coarse Aggregate in Concretes for Rigid Pavements, Transportation Research Record, No. 2113, 2009.
- Vanikar S. N., Grove J., and Wathn L., Leaving a Smaller Footprint, Public Roads, Vol. 73, No. 6, May/June 2010.
- Weinfurter, J. A., Smiley D. L., and Till R. D., Construction of European Concrete Pavement on Northbound I-75, Detroit. Michigan, Lansing, Michigan, 1994.
- Wojakowski J. B., High Performance Concrete Pavement, FHWA Construction Report, Report No. FHWA-KS-98/2, Topeka, Kansas, 1998.

APPENDIX A CASE STUDIES

FLORIDA US-41, 1977

General Information

This experimental project is located in the southbound lane of SR 45 in Charlot County, between Fort Myers and Punta Gorda. Construction started at 1976 and opened to traffic 1978. More than 5.1 million trucks (6.2 million ESALs) have used this road before the 30 years performance evaluation was done in 2007. This experimental 2LCP project was consisted of series of two-layer pavement sections with different varying design features. Asphalt overlay of 10 in. thickness on 9 in. Econocrete was initially included in the project but is not included in this report, as it is outside the scope of this project.

Florida's two lift concrete pavement project is the first in U.S. with thorough long-term performance analysis. Some important observations were obtained from this experimental study including two lift concrete pavement with 20 feet long section, 90° transverse joint, dowels and granular subbase performed the best; other sections with granular subbase and 15 feet section length with skewed joint experienced slightly higher corner deflection and faulting; cement treated subbase performed poorly almost every section, showing the high durability of cement treated subbase; and overall performance of the two lift pavement is better than control full depth pavement.

Material and Pavement Characteristics

This experimental 2LCP project was consisted of series of two-layer pavement sections with different varying design features. Asphalt overlay of 10 in. thickness on 9 in. Econocrete was initially included in the project but is not included in this report, as it is outside the scope of this project. Table 6 and Table 7 showed the important design parameters and properties of concrete used in the experimental sections.

Table 6. Summary of Experimental Section (Greene et al. 2011).

Section	Control	1A	1B	1C	2A	2B	2C	3A	3B	4 and 5
Top layer thickness	9" PCC	3" PCC			3" PCC			3" PCC		2 to 3"
PCC reinforcement	None	None			None			None		Various
Joint spacing/ Orientation	20'/90°	15'/Skewed			15'/90°			20'/ 90°		Experimental joint
Load transfer mechanism	None	None			None			1" dia.- 18" long and 12" spacing		None
Top/bottom layer interface	NA	Monolithic bond			Monolithic bond			Monolithic bond		Bonded/ Unbonded
Bottom layer Econocrete	NA	9" Mix A	9" Mix B	9" Mix C	9" Mix A	9" Mix B	9" Mix C	9" Mix A	9" Mix B	9" Mix B
Subgrade	6" cement treated	6" granular			6" cement treated			6" granular		6" granular

The control section is a full depth JPCP known as CPCD in Texas. The concrete surface was 9 in. thick Portland cement concrete (PCC) constructed on a 6 in. cement-treated subbase. Joint spacing was 20 ft with 90° joints. There were a total of five experimental two layer pavement sections. Sections 1 to 3 consisted of 3 in. CPCD of the same mix design and properties of control section placed over 9 in. Econocrete bottom layer. To enhance the bond between the layers, bottom layer was tined. The time interval between the top and bottom layer was 1/2 to 1 hour. Monolithic bonding was considered to be obtained because of the short time gap between the two lift. Econocrete cement content was varied to achieve three different strength levels. Properties of used concrete and Econocrete are shown in Table 7. Dowel bars were provided in section 3. Eighteen inch long and 1 in. diameter dowel bars were placed at half depth of the total thickness of the two layer pavement at 12 in. center to center distance. For section 1 transverse joint was cut at a skewed orientation, and for section 2 and 3 the orientation was right angle. Dowel bars were also placed accordingly to match the transverse joint. Section 4 consists of 3 in. reinforced PCC layer on the top of 9 in. Econocrete. Steel or wire mesh was used for reinforcing the top layer. Bond between Econocrete and the top PCC layer was prohibited on

one of the sub-section. Section 5 had 2 in. and 3 in. steel fiber reinforced concrete top layer. Workability of the concrete was limited due to the clumpy nature of the steel fiber.

Table 7. Properties of Concrete and Econocrete (Greene et al. 2011) .

Property	Test Value			
	PCC	Econocrete Mix A	Econocrete Mix B	Econocrete Mix C
Compressive Strength (psi)	5,110	1,955	1,280	675
Modulus of Rupture (psi)	735	380	280	160
Split tensile strength (psi)	515	250	175	93
Modulus of elasticity (ksi)	5,750	2,210	1,730	1,290
Air content (%)	3.8	4.1	3.8	4.1
Slump (in.)	1.6	1.8	1.9	1.7
Unite weight (lb/ft ³)	141	132	133	132

Construction

Figure 16 presents representative photos during different stages of 2LCP construction in the Florida US-41 project.

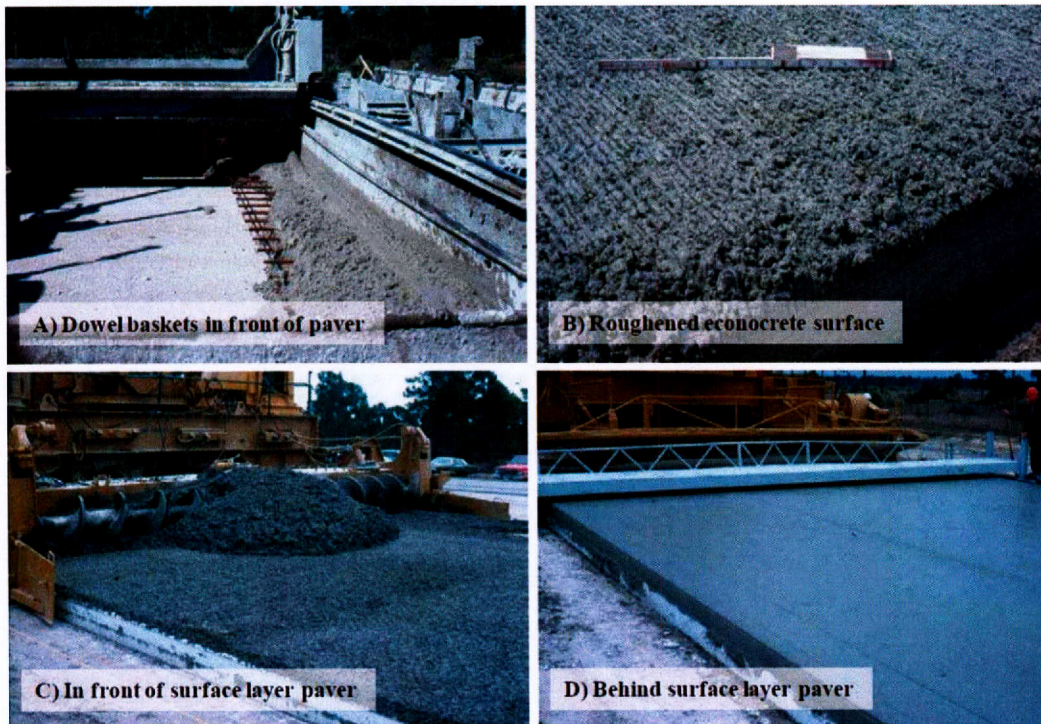

Figure 17. Paving Operation in Florida US-41 2LCP Construction (Greene et al. 2010).

Performance

This project is one of the most complete 2LCP research projects with available performance data. The primary parameters that were used to evaluate the performance of the experimental pavement sections include pavement deflection, load transfer, joint faulting, pavement smoothness, and pavement cracking.

To determine the pavement stiffness, joint edge deflection, and loss of support, a detail deflection measurement survey was performed in October 2007. To determine the curling effect due to the thermal gradient of the pavement concrete, a falling weight deflectometer (FWD) test was performed during both day and night time. Deflection measurement was taken at center of the slab, outside corner, and the joint edge along the outside wheel path of the outer lane. Nighttime stiffness of the pavement slabs was 67 percent higher than the daytime stiffness. Full depth concrete pavement was less stiff than the two lift pavement sections. It may be due to the higher thickness of the two lift pavement sections. The control section showed higher deflection than all the two lift pavement sections. This higher deflection shows a higher loss in support in the control section.

Load transfer was measured at the outside wheel path of the outer slab. All the experimental pavement sections showed almost similar efficiency in load transfer. Moderate to severe spalling was observed in control section, whereas section 1 and 2 showed moderate spalling. Section with cement treated subbase showed higher faulting than the sections with granular subbase. Higher faulting, corner deflection, and evidence of higher pumping in cement treated subbase indicates higher durability of the cement treated subbase than the granular subbase.

International Roughness Index (IRI) was measured every year after the pavement sections were open to traffic. Most of the two lift pavements showed satisfactory IRI value after 25 years. Control section, section 1A, and 2C maintained a satisfactory IRI value till 15 years of the service life, and then deteriorated rapidly.

Full crack evaluation was performed in 2007. Longitudinal crack was the most predominant. Longitudinal crack was observed mostly along the wheel path, longitudinal joint, and along the center of the slab. Higher longitudinal crack was observed in the control section and section 2, reinforcing that cement treated subbase more susceptible to longitudinal crack than granular subbase. Some subsections in section 4 and 5 included an experimental plastic cracking

induction joint. These joints were constructed by placing the debonding agent at a different distance. Transverse cracks appeared over time in the approximate locations, but longitudinal cracks also appeared in those experimental joints resulting in heavy spalling at those experimental joint. These heavy spalled sections were removed within one year of the service life due to the poor serviceability.

MICHIGAN I-75, 1993

General Information

In 1993, the Michigan Department of Transportation (MDOT) conducted the European pavement design demonstration project in Detroit on north bound I-75 to compare the performance and economy of European rigid pavement to the pavement practice in the United States. This project was an outcome of the experiences obtained from the 1992 FHWA scanning tour study of European concrete pavements. The test section was a 2.3-mile reconstruction of I-75 between I-375 and I-94. Approximately 1 mile of pavement was constructed according to European two-lift concrete pavement (Euro-2LCP) design, and the rest is constructed using a standard 1993 MDOT pavement design.

MDOT and FHWA closely monitored the performance of test section. No significant performance differences were observed between these two types of pavement after 5 years of service life (Buch et al. 2000). Based on the data available in 2007, a 15 years performance of these two test sections were reported (Smiley 2010). Further discussions are based on the major findings of this report.

Material and Pavement Characteristics

The Euro-2LCP was a 10-in. two-lift (7.5-in. bottom lift and 2.5-in. top lift) jointed concrete pavement with exposed aggregate surface. The base was made of 6-in. lean concrete with 6-in. under drains. A 16-in. aggregate subbase placed on an existing prepared subgrade. Doweled transverse joints were placed at 15-ft intervals. A typical 1993 MDOT section was a jointed-reinforced concrete pavement. Eleven-inch single layer concrete with standard surface texture placed on 4-in. open graded drainage course with 6-in. under drains. A 12-in. sand

subbase was placed on existing prepared subgrade. Doweled transverse joints were placed in 41-ft intervals. Additional design details will be found elsewhere (Weinfurter et al. 1994).

Construction

The 2LCP section was a 10-in. two-lift (7.5-in. bottom lift and 2.5-in. top lift) jointed concrete pavement with exposed aggregate concrete surface. The standard MDOT section was a jointed-reinforced concrete pavement, with 11-in. single layer concrete (Weinfurter et al. 1994). During the construction, the same sources for cement and aggregate were used in both 2LCP and standard sections, except a 0.33-in. maximum size crushed basalt stone was used for the top lift of the 2LCP section to meet the wear (polishing) EAC requirements.

Cost

Life cycle cost analysis showed that Euro-2LCP is economical over JRCP, if the initial cost of Euro-2LCP does not exceed more than 17 percent of the initial cost of the JRCP. However, in this project initial cost of the Euro-pavement test section was more than twice of the initial cost of JRCP. The higher cost of the 2LCP can be due to the size of the job and uncertainty driven from the inexperience of the contractor of building 2LCP.

Performance

Distress index (DI) values were determined to measure the level of distresses. DI values of both the pavement types did not change significantly after their construction. However, Euro-2LCP consistently showed higher average DI values than MDOT pavement. Ride quality was measured through the International Roughness Index (IRI) and Michigan Ride Quality Index (RQI). Further details about RQI and calculation techniques can be found elsewhere (Smiley 1996). Although, standard JRCP pavement scored better in both indexes, both the pavement types provide acceptable ride quality. Skid resistance of pavement is another property that relates to safety of the vehicles. Skid resistance of the pavement surface was measured through Friction Number (FN). The JRCP surfacing provides better surface friction than exposed aggregate surface. Surface friction of the exposed aggregate surface depends on the spacing of the aggregates. Excessive spacing increased macro-texture, and this may be the cause of low FN

values of Euro-2LCP. However, exposed aggregate surfacing provided low noise level. Longitudinal cracks were also observed in Euro-2LCP where, JRCP did not. Multiple cores from Euro-2LCP confirmed that cracks were running through the whole thickness of the pavement but did not continue through the lean concrete base. Delamination and spalling were also observed in Euro-pavement, however no separation was observed in the top and bottom layer interface. Low air content at the top layer was not enough to withstand the freezing and thawing and identified as the major cause of these distresses. According to the performance evaluation of the two test sections by MDOT and FHWA, no significant performance differences were observed between these two types of pavement after 5 and 15 years of service (Buch et al. 2000; Smiley 2000).

BELGIUM E34 MOTORWAY, 2005

General Information

Approximately 40 percent of Belgian main roads consist of concrete paving. For the last 20 years these roads have been constructed of continuously reinforced single-lift pavement. The 2LCP method of paving is regularly used for ornamental colored concrete to reduce the cost of the expensive coloring agents and stones. It was recently selected to replace sections of the E34 roadway that was placed in 1977. Many of these sections have experienced serious step forming along the initially dowelled joints. The average daily traffic of this roadway is approximately 23,000 vehicles with 25 percent of this consisting of large trucks. The practice of two-layered CRCP had previously been tested on two sections on the roads in this region. The first was concerned with low-noise pavement, which consisted of a 7-in. (18cm) CRC lower course that received differing top-lifts of fine EAC, porous concrete, split mastic asphalt, and porous asphalt. After 12 years testing, researchers concluded that the EAC performed best for sound reduction and durability. The second experimental section involved five test sections that rendered equal results that also proved to offer a much higher quality of evenness for the driving surface (Rens et al. 2008).

Material and Pavement Characteristics

In the sections of the E34 that were replaced by two-layered CRCP, the reinforcement of this pavement did not differ from the single lift pavement. This consisted of 3/4-in. (20 mm)

diameter longitudinal reinforcement and 5/8-in. (16 mm) traverse reinforcement at a 60° angle. This design can be seen in Figure 18 and compared to the typical and standard pavements in Belgium. The specifications required 3.15-in. of concrete coverage over the reinforcement, which placed the steel in the lower lift. The mix design and air content of fresh concrete on site of both courses is shown in Table 8.

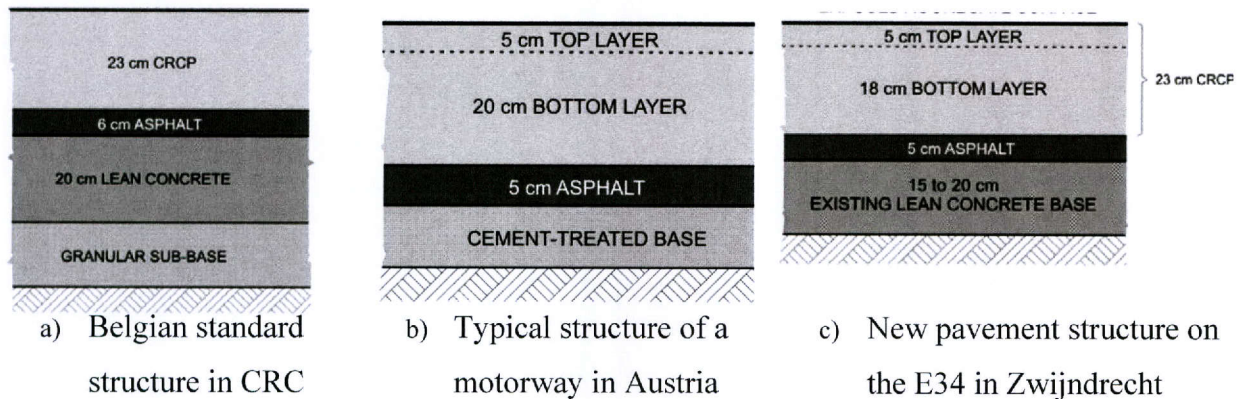

Figure 18. Different Lift Thicknesses and Characteristics (Rens et al. 2008).

Table 8. Mix Design for Belgium E-34 Motorway Project.

	Upper Course	Lower Course
Coarse aggregate	Broken stone 4/6.3 with polishing resistance requirements $PSV \geq 50$, no recycled material allowed.	Broken stone 4/6.3 – 6.3/2 – 20/32 of which 60% recycled materials originally from the broken-up slab shared among the 6.3/20 and 20/32 fractions, and 40% natural crushed stone with no polishing resistance requirements.
Fine aggregate	Sand for pavement concrete, no recycled material allowed.	Sand for pavement concrete with no recycled material allowed.
Blast furnace slag cement	minimum 425 kg/m ³	minimum 375 kg/m ³
w/c	≤ 0.45	≤ 0.45
Air content	$\geq 5\%$	$\geq 3\%$

Construction

One major challenge that was overcome was due to the limited space allowed for the delivery of the different mixes. Only one route was to be used for both supplies and therefore required meticulous coordination. A mobile batch plant was located nearby that serviced both design mixes. This plant serviced at a 3:1 bottom-lift to top-lift ratio. Figure 19 shows construction of double-layered CRCP in the E34 project.



Figure 19. CRCP Construction in E34 Motorway Construction (Ren 2008).

The 7250 psi (50 MPa) cube compression strength requirement for the upper course was often not obtained. This was thought to be caused by the specified high level of air content (5 percent). Researchers noticed that a 1 percent increase in air content would prove a 725 psi (5 MPa) decrease in compression strength.

Performance

A major advantage to 2LCP with two pavers is that the machine laying the top lift only has to lay a limited amount of concrete that offers a much higher degree of surface evenness. The contractor attributed the highly homogeneous exposed aggregate to the fine granulometry composition of the upper course. Through OBSI testing, it was determined that the EAC two-lift pavement reduced the noise level by 3 dBA compared to single-lift EAC along the E34.

KANSAS I-70, 2008

General Information

Among the few recent U.S. experiences of 2LCP, one of the most well-known projects is the demonstration project conducted by Kansas DOT in 2008. The project was a 5-mile section

on the eastbound of I-70 near Salina, KS. The project featured the use of a standard KDOT paving mix and locally available porous limestone aggregate for the 11.8-in. bottom lift, and rhyolite aggregate (imported from Oklahoma) along with 20 percent replacement of cement with a class F fly ash-gypsum blended in the 1.6-in. top layer. The pavement also featured test sections with several different pavement surface textures, including longitudinal tinning, exposed aggregate, grooving and Astroturf drag (Shields-Cook and Taylor 2009). The two-lift paving process was found to be a practical approach that worked well with the paving methods and equipment employed by U.S. contractors.

Material and Pavement Characteristics

Mix designs of concrete used in the bottom lift and top lift (both textured sections and the EAC section) can be found in Table 9.

Table 9. Mix Design for Kansas I-70 2008 Project (Vanikar 2010).

	Bottom Lift	Top Lift (Textured Sections)	Top Lift (EAC Section)
Portland Cement Type I/II (pcy)	548	438	526
Class F Fly Ash (pcy)		110	132
Water (pcy)	236	236	270
Coarse Agg: Fine Agg. Ratio	60:40	50:50	70:30
w/cm	0.43	0.43	0.41
Design Air Content	6.5%	6.5%	6.5%
Air Entraining Admixture (oz/yd ³)	14	20	20
Mid-Range Water Reducer (oz/yd ³)	5		
Anti-Bleed/Anti-Segregate Admixture (oz/yd ³)	5.5		
Type A Water Reducer (oz/cwt)		5	5

Construction

A dual drum central mix plant was used for batching and mixing both concrete mixtures, which maximized efficient control of concrete delivery. Concrete was transported in tractor-trailer end dumps and tandem axle dump trucks, and color coding was used to distinguish concrete mixtures for the two different lifts. Figure 20 shows a photo during 2LCP construction in the Kansas I-70 project in 2008.



Figure 20. 2LCP construction in Kansas I-70 Project (Gerhardt 2013).

Koss Construction Company, who completed two test sections before attempting this project, noted areas of difficulty that were engineered out prior to construction of the I-70 pavement sections. Koss reduced the width of the top lift by 1 in. to minimize complications caused by differences in width and alignment of the two lifts. A central mix plant was also used to maximize efficient control of concrete delivery. Last, the original liquid curing compound was replaced with polyethylene sheets to allow for proper sweeping required for a desirable EAC finish (Fick 2008).

Cost

In a summary of cost comparison of standard paving and 2LCP from the Kansas project (Howard 2009), it was identified that 2LCP was \$8 more than a standard mix and \$7 lower than a durable mix.

Table 10. Cost Comparison of Standard Paving and 2LCP from Kansas 2008 Project.

Type of Pavement	Thickness	Materials Cost (CY)	Pavement Cost-in-Place (CY)	Pavement Cost (SY)
Standard Mix	12"	\$57	\$99	\$33
Durable Mix	12"	\$102	\$144	\$48
Bottom Lift	10"	\$57	\$108	\$30
Surface Lift	2"	\$102	\$190	\$11
Two Lift	12"			\$41

PENNSYLVANIA MON-FAYETTE EXPRESSWAY, 2008

General Information

Portions of the Mon-Fayette Expressway in Pennsylvania were also placed using 2LCP. Interestingly, the contractor proposed this method as an alternate for the project to provide the highest level of surface finish by an increased level of control of the thin top lift. It was also proposed that this delivery would reduce the project cost. The difference with this project is that both top and bottom lifts were placed wet on wet with identical mix designs.

Material and Pavement Characteristics

This 12-in. concrete pavement was placed in two lifts: an 8-in. lower lift and a 4-in. top lift. The same concrete mixture was used in both the top and bottom lifts.

Construction

While the contractor managed to construct the two test sections smoothly, preliminary results suggested that exposed aggregate surfacing can provide more than adequate friction for driver safety, but does not provide significant noise reduction from typical HMA or diamond grinding surfaces (Akkari and Izevbekhai 2011). This test project was riddled with complications. The QC process rejected five loads of concrete intended for the two pavement sections generally due to improper slump. Despite the rejected loads the time lag between the remaining 60 trucks ranged from 14–123 minutes. The degree of control influencing time lag is critical for the proper placement of the 2LCP to ensure product quality and durability.

The contractor noted that it is possible to do two-lift paving using a single batch plant and paver by using additional aggregate bins present at the single batch plant and by using a spreader to place the lower lift. However, he also noted that careful coordination would be required to

ensure adequate production of both mixtures to avoid having to stop and restart either paver (particularly the top lift paver), which could result in irregular surface quality and smoothness problems. He further noted that two-lift paving is probably best suited for large paving projects that require high production quantities (e.g., thick mainline highway pavement or airfield paving projects) (Bilec 2010).

It seems clear that PennDOT could use two-lift paving techniques to make better use of VanPort limestone, recycled concrete, and other aggregate sources and materials that may not be suitable for use in concrete pavement surface layers. One key to successful implementation may be to ensure that the adoption of this technology can be done cost-effectively and that the concrete paving industry does not perceive it as a threat to their ability to compete with the asphalt industry (Bilec 2010).

MINNESOTA I-94, 2010

General Information

The Minnesota Department of Transportation (MnRoad) R21 “Composite Pavements” project was developed by the second generation of the Strategic Highway Research Program (SHRP2) to investigate the design and construction of new composite pavement systems. MnRoad recently conducted two test sections with RCA and relaxed aggregate gradation in two different test sections, respectively. While the contractor managed to construct the two test sections smoothly, preliminary results suggested that exposed aggregate surfacing can provide more than adequate friction for driver safety, but does not provide significant noise reduction from typical HMA or diamond grinding surfaces (Akkari and Izevbekhai 2011).

Material and Pavement Characteristics

Within the whole R21 project, two sections (Cell 71 and Cell 72) were constructed using 2LCP. Both sections were constructed with a 2-in high-quality EAC top lift over a 6-in. “low cost” bottom lift, with lean content of approximately 250lb/yd³ of cement and 60 percent of fly ash replacement. Top-lift concrete had a cement content of approximately 550lb/yd³ and 15 percent fly ash. MnRoad Class A aggregate with a maximum size of 1.25-in. and crushed granite with a maximum size of 3/8-in. were used in bottom and top lifts, respectively. The difference between the two sections was that 50 percent RCA replacement was used in the

bottom lift of Cell 71. In addition to the EAC that was used in both sections, diamond grinding was also applied on a portion of Cell 72. Concrete mixture designs used in Cell 71 and 72 are shown in Table 11. Cross sections of the 2LCP sections in the Minnesota project are shown in Figure 21.

Table 11. SHRP2 R21 PCC/PCC Design for MnRoad Sections.

Section		EAC over RCA PCC (Cell 71)	EAC over Low-cost PCC (Cells 71 and 72)
Upper PCC	Thickness	3"	3"
	Mix	High portland cement (~550 lb/yd ³) 15% Fly ash, Class C	High portland cement (~550 lb/yd ³) 15% Fly ash, Class C
	Coarse Aggregate	Crushed granite (maximum size 3/8")	Crushed granite (maximum size 3/8")
Lower PCC	Thickness	6"	6"
	Mix	Low portland cement (~250 lb/yd ³) 60% Fly ash	Low portland cement (~250 lb/yd ³) 60% Fly ash
	Coarse Aggregate	50% RCA, 50% MnRoad Class A Max aggregate size 1.25"	100% MnRoad Class A Max aggregate size 1.25"
Base		8" Class 5 unbound	8" Class 5 unbound
Subgrade		Clay	Clay
Joint Spacing		15 ft	15 ft
Doweling		1.25" (located 4.5" from top of base)	1.25" (located 4.5" from top of base)
Surface Texture		EAC	EAC /Diamond grind



Figure 21. Cross Section of 2LCP Section in Minnesota I-94 Project (Rao and Darter 2011).

Construction

Figure 22 shows the paving train constructing the research sections along I-94 2LCP section. The mixer truck, first paver, material transfer device, and second paver used for the 2LCP construction are shown in the figure from left to right.

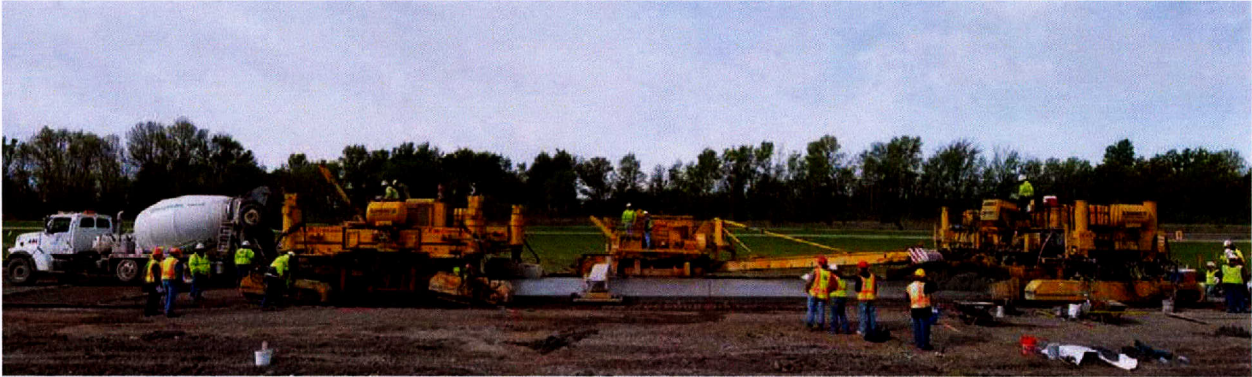

Figure 22. Paving Train Constructing R21 Research Sections along I-94 at MnRoad (Tompkins et al. 2011).

One objective of the R21 research is to focus on a composite pavement system featuring a thin PCC layer placed over another PCC layer. The top lift was specified to be placed between 15 and 90 minutes after the placement of the bottom lift. This specification was in response to concerns of German and Austrian consultants to the R21 project and observations collected on the R21 scanning tour of European composite pavements. The general consensus among the research team was that the placement of the top lift—as soon after the bottom lift as possible—was important to eliminating problems that might be associated with the heterogeneity of the two concretes in the PCC/PCC pavement. These problems include differential shrinkage, different rates of hydration, and the compound problem of bonding at the interface of the two PCCs. While the use of two pavers was an initial step to meeting this specification, there were other logistics that needed to be fulfilled to ensure the lifts were placed within a maximum of 90 minutes of one another (Tompkins 2010).

The most uncertain aspect of the MnRoad construction was the surface texturing. Initially, the project had planned on the import of European experts to guide the project contractor in the EAC brushing efforts on site at MnRoad. However, these experts were unable to guide the project personally, and instead their advice was used by the project team to develop its own expertise (Tompkins 2010).

Complications of the paving operations were greatly attributed to the delay in the PCC delivery for both mixes that comprised the two lifts. These may have been caused by the concrete supplier's inexperience with certain mix designs. Due to the small portions that were to be paved, the contractor opted to hire a local ready-mix company to supply the PCC rather than the traditional mobile batch plants that would be used on large paving operations. The supplier that was selected was not experienced with the high levels of fly-ash that was specified for these portions and this resulted in 0.25–0.75 in. slumps to be tested in the field that were specified to be 1 in.

The lesson learned from the R21 team was that viable mix designs should be specified until 2LCP has become an established practice in the United States. The team concluded that the specified mix design, the use of a single batch plant, and the need to understand EAC brushing were the top challenges that were faced (Tompkins 2010).

Cost

Cost comparison from the project is summarized in Table 12. According to Krummen (2012), there is a \$135,000 Net Cost Advantage, which translated to \$0.44/cy less in constructing composite concrete pavement section with 2LCP practice.

Table 12. Cost Comparison from MnRoad SHRP2 2010 Project.

		Conventional Concrete	Composite Concrete
Construction	Pavement Section	309,645 sy	309,645 sy
	Crew Size	12 people	18 people
	Unit Paving Cost	\$2.614/sy	\$4.278/sy
	Total Paving Cost	\$809,508	\$1,324,552
Material	Concrete Amount	77,441 cy	77,441 cy
	Unit Concrete Cost	\$71.063/cy	\$62.656/cy
	Total Concrete Cost	\$5,501,095	\$4,850,349
Total Pavement Cost		\$6,310,603	\$6,174,901
Unit Total Cost		\$20.38/sy	\$19.94/sy

Comparison of detailed equipment requirements from the project is shown in Table 13. In the table, composite costs include extra batch plant, paver, belt placer, cure/texture cart, bristle broom, and EAC texturing. There was a 2-hour round haul for Class A aggregate (surface of composite but full thickness of conventional) and 20-minute round haul for RCA (lower PCC for composite).

Table 13. Comparison of Equipment Requirements from MnRoad I-94 Project (Krummen 2012).

	Conventional Concrete	Composite Concrete
Concrete Placement Comparison	Boom Truck	Boom Truck
	GP-2800 Paver	GP-2800 Pavers (2)
	PS-60 Belt Placer	PS-60 Belt Placers (2)
	T/C-400B Texture/Cure	T/C-400B Texture/Cure (2)
	Skid Loader	Skid Loader
		Texture Broom
	Pickup	Pickup
	Service Truck	Service Truck
	Flatbed Truck	Flatbed Truck
	Water Truck	Water Truck
	13 People	18 People
	~\$9,000/day Paving Crew	~\$15,000/day Paving Crew
	27 Paving Days	34 Paving Days
	Production Cost Comparison	Mobilization – \$73,000
Concrete Materials – \$5,292,000		Conc. Matls (CA=\$10.50) – \$4,556,000
Plant Production – \$527,000		Plant Production (20% less) – \$557,000
Contractor QC – \$85,000		Contractor QC – \$116,000
Incentives – (\$476,000)		Incentives – (476,000)
Total Cost – \$5,501,000		Total Cost – \$4,850,000
Unit Cost – \$71.07/cy		Unit Cost – \$62.66/cy
		\$651,000 Material Advantage
Placement Cost Comparison		\$8.41/cy less
	Paving – \$344,000	Paving – \$609,000
	Placement Materials – \$230,000	Placement Materials – \$481,000
	Green-Saw – \$235,000	Green-Saw – \$235,000
	Total Placement Cost – \$809,000	Total Placement Cost – \$1,325,000
	Unit Cost – \$2.61/sy	Unit Cost – \$4.28/sy
	\$516,000 Placement Advantage	
	\$1.67/sy less	
Total Pavement Cost Comparison	Mix Production – \$5,501,000	Mix Production – \$4,850,000
	Pavement Placement – \$809,000	Pavement Placement – \$1,325,000
	Total Pavement Cost – \$6,310,000	Total Pavement Cost – \$6,175,000
	Unit Cost – \$20.38/sy	Unit Cost – \$19.94/sy
		\$135,000 Net Cost Advantage
		\$0.44/cy less
	(2% Discount)	

ILLINOIS TOLLWAY, 2012

General

In an effort to obtain sustainable and economical pavement, Illinois Tollway is looking for alternate methods of pavement construction. Recycling the old pavement materials is always an objective of the Tollway. A 0.7 mile demonstration project was done in 2012 on I-88. Two-lift concrete pavement was used for this project. The construction of the Illinois Tollway is still in progress and a national open house was hosted in summer 2013.

Material and Pavement Characteristics

Material obtained from old asphalt pavement is fractionated and divided into fine and coarse fractions by a No. 4 sieve. The fine part is generally reused as binder in asphalt pavement, leaving behind huge quantities of coarse aggregates. Illinois Tollway was actively searching for ways to use this fractionated recycled asphalt pavement (FRAP) in pavement construction (Rao et al. 2013). Bottom lift concrete was designed with 15 to 50 percent FRAP replacement, with excess recycled RAP asphalt coarse aggregate “black rock” as intermediate-sized aggregate. Ternary blend cement was used with 35 to 50 percent cement replacement. Water-to-cementitious material ratio (w/cm) of 0.37 was used. Cementitious material content was 630 lb/yd³.

Additional laboratory studies performed. Compressive strength, split tensile strength, flexural strength, static elastic modulus, and dynamic modulus decreased with increased FRAP use. A beam test also showed lower fracture energy at higher replacement. Results showed that despite the inferior mechanical performance of FRAP, concrete with 50 percent FRAP replacement met the Illinois Department of Transportation (IDOT) strength requirement for pavement concrete. Test results also showed that concrete slabs with RFAP had higher fracture energy than the virgin concrete. This finding opened the door to use FRAP in concrete pavement.

Construction

Figure 23 presented 2LCP construction in the ongoing Illinois Tollway 2LCP project. Because of union rules that require a large crew for each paver, only one “slip-form paver” was used (in the construction of the top lift). The bottom lift was placed with a spreader that had steel side panels and a rough strike-off but no vibration.



Figure 23. 2LCP Construction in Illinois Tollway (Photo Courtesy of Meininger).

Cost

The bid openings for all of the reconstructed and widened I-90 eastbound lanes between Rockford and Elgin occurred within the last several months. The pavements were designed for three different thicknesses to accommodate differing traffic loads on the pavement. The column on the left of your screen shows the average bid prices for 12 in. jointed plain concrete pavements that were built under the CRP program. These pavements were bid when cement prices were higher, when the economy was in a better state, and on projects where counter flow maintenance of traffic set ups tended to impact pavement prices. Therefore if these factors were accounted for and assume a 12 in. single lift JPCP, a bid today would be a few dollars a square yard cheaper than the prices received during the last decade, then the reduced prices seen on bid tabs received to date shown in the right column suggest composite pavements to be much more economical. Somewhere around \$5 to \$10 million in reduced price on the first stage of the I-90 reconstruction can be attributed to the composite pavement factor alone. Since this is just the first of four stages to rebuild the interstate, tens of millions of dollars can be saved on the overall corridor project. A good return on all of investments into bringing this old concept for paving back into the picture. It is suggested that other agencies look into it for future large scale concrete paving projects.

Table 14 shows a cost comparison of 2LCP construction and traditional paving construction. In the table, the conventional paving construction cost was based on expected prices based on 2004–2008 JPCP contracts, and the 2LCP construction cost was based on average bid process received on six 2013 jobs for composite JPCP. Due to the use of recycled aggregate, 2LCP was about 25 to 30 percent cheaper than the conventional jointed pavement (Rao 2103).

Table 14. Cost Comparison of 2LCP vs. Traditional Paving in Illinois Tollway Project (Rao 2013).

	Conventional Paving	2LCP
Pavement section	> 3,000,000 Sq. Yds. of JPCP Built System wide	> 3,000,000 Sq. Yds. of JPCP Built System wide
11.25" JPCP	\$61.00/SY	\$40.66/SY
12" JPCP	\$65.00/SY	\$45.92/SY
13" JPCP	\$70.00/SY	\$49.70/SY

APPENDIX B SURVEY A QUESTIONS

(0-6742) Survey for Personnel with Two-Lift Paving (2LCP) Experience

1. Please provide the following contact information so that we may contact you if we have further questions.

Name:

Organization:

Email address:

Telephone:

(0-6742) Survey for Personnel with Two-Lift Paving (2LCP) Experience

General Information

2. How many years do you have with paving experience?

- 0-5
 6-10
 11-15
 Over 16

3. Which of the following best describe your field of experience in paving?

- Design
 Construction
 Research
 Equipment Manufacturer/Designer

Other (please specify)

4. Please fill in the blanks below pertaining to your previous 2LCP experience.

- a. Location(s)
- b. Completion date(s)
- c. Lane miles of paving(s)
- d. Average daily traffic (ADT)

5. Major reason for using 2LCP vs. traditional paving?

- Aggregate availability
 Surface characteristics
 Economic
 Experimentation

Other reason(s) (please specify)

(0-6742) Survey for Personnel with Two-Lift Paving (2LCP) Experience

Mix Design and Material Properties

6. Please fill in the blanks below pertaining to your previous 2LCP experience. [Top lift]

Supplier	<input type="text"/>
Mix design ID #	<input type="text"/>
Thickness (Inch)	<input type="text"/>
Coarse aggregate type	<input type="text"/>
Fine aggregate type	<input type="text"/>

7. Please fill in the blanks below pertaining to your previous 2LCP experience. [Bottom lift]

Supplier	<input type="text"/>
Mix design ID #	<input type="text"/>
Thickness (Inch)	<input type="text"/>
Coarse aggregate type	<input type="text"/>
Fine aggregate type	<input type="text"/>

8. Will you be able to provide detailed mix design through email?

- Yes
- No

(0-6742) Survey for Personnel with Two-Lift Paving (2LCP) Experience

Construction

9. Please rate the following aspects of 2LCP vs. traditional paving methods (1 = the same, 3 = extra effort required, 5 = substantial impact):

	1	2	3	4	5
Scheduling	<input type="radio"/>	<input type="radio"/>	<input type="radio"/>	<input type="radio"/>	<input type="radio"/>
Additional equipment	<input type="radio"/>	<input type="radio"/>	<input type="radio"/>	<input type="radio"/>	<input type="radio"/>
Aggregate selection	<input type="radio"/>	<input type="radio"/>	<input type="radio"/>	<input type="radio"/>	<input type="radio"/>
Mixing	<input type="radio"/>	<input type="radio"/>	<input type="radio"/>	<input type="radio"/>	<input type="radio"/>
Placing	<input type="radio"/>	<input type="radio"/>	<input type="radio"/>	<input type="radio"/>	<input type="radio"/>
Consolidation	<input type="radio"/>	<input type="radio"/>	<input type="radio"/>	<input type="radio"/>	<input type="radio"/>
Curing	<input type="radio"/>	<input type="radio"/>	<input type="radio"/>	<input type="radio"/>	<input type="radio"/>
QA/QC	<input type="radio"/>	<input type="radio"/>	<input type="radio"/>	<input type="radio"/>	<input type="radio"/>

10. Please identify the way(s) that challenges of 2LCP were overcome most.

- Extra supervision
- Unexpected expenditures
- Preplanning

Other

(0-6742) Survey for Personnel with Two-Lift Paving (2LCP) Experience

Cost

11. Which of the following attributed to the greatest impact to overall 2LCP project cost?

- Extra supervision
- Extra equipment
- Extra manpower
- Unexpected expenditures
- Preplanning

Other

(0-6742) Survey for Personnel with Two-Lift Paving (2LCP) Experience

Overall

12. On a scale of 1-5 (1=worse and 5=best), please rate your overall experience with 2LCP

 1 2 3 4 5

13. Would you like to participate on another 2LCP project?

 Yes No

14. On a scale of 1-5 (1=immediate need and 5 = no need at all), please rate your opinion on need for a 2LCP at this time.

 1 2 3 4 5

Briefly explain why you make the above mentioned choice.

15. If you chose there is not a need for 2LCP at this time, when do you think there will be a need?

 In 1 to 2 years In 3 to 5 years In 6 to 10 years In 11 to 20 years In 21 to 30 years More than 30 years

16. Please list any person(s) who you would suggest being contacted regarding the implementation of 2LCP.

APPENDIX C LIST OF PERSONNEL IN SURVEY A

Table 15. List of Personnel in Survey A.

Name	Affiliations	Project
Peter Schöller	Österreichische Betondecken Arge	Europe
Ronald Blab	Vienna University of Technology	Austria, Germany and Slovenia
Luc Rens	FEBELCEM - EUPAVE	Belgium
Thomas Sorel	MnDOT	MnRoad
Thomas Kazmierowski	Ontario Ministry of Transportation	Highway 407, Toronto
José Tadeu BALBO	USP	NA
Arjan Venmans	provincie Noord-Brabant The Netherlands	Veghel, The Netherlands, secondary road N279
Jussara Tanesi	FHWA-TFHRC-HRDI Aggregate/Petrographic Lab (APL)	Kansas I-70
Ben Worel	Minnesota Department of Transportation	MnRoad (Interstate - 94)
James Crites	Parsons Corp (on behalf of DFW Airport)	NA
Richard Abell	Highways Agency	Kessignland, Suffolk
Mark B Snyder	ACPA - PA Chapter	Pennsylvania Turnpike - Mon-Fayette Expwy
Mark Watson	Minnesota Department of Transportation	MnRoad I-94
Suneel N. Vanikar	FHWA	Several demonstration projects in USA
Denis Thebeau	Ministere des transports du Quebec	Hwy 15 Mirabel Northboun Quebec Canada
John Donegan	Aggregate Industries UK	A449 - South Wales, UK
Alfred Weninger-Vycudil	PMS-Consult GmbH, Naglergasse 7, Vienna, Austria	Austria and Germany
Steven Gillen	Illinois Tollway	I-88 Illinois Tollway
Robert Rasmussen	Transtec	I-70, Europe
Jim Grove	FHWA	Kansas I-70
Tom Cackler	CP Tech	Kansas I-70
James Cable	Cable Construction	NA
Gary Fick	Trinity Construction	Kansas I-70
Tim Gerhardt	Koss Construction	Kansas I-70
Ron Meskis	Gunter & Zimmerman	NA

APPENDIX D SUMMARY OF SURVEY A RESULTS

In Task 2, the research team developed two sets of surveys with specific questions to obtain additional information and insights concerning the application of two-lift concrete paving (2LCP). Survey A (Surveys of contractors and agencies experience with 2LCP) targets contractors and agencies with experience on working with 2LCP. Survey B (Surveys of contractors and TxDOT personnel regarding concerns on 2LCP) targets TxDOT personnel and contractors with concerns in implementation of 2LCP in Texas. Survey Monkey® was used to conduct online surveys. Phone interviews with the same two sets of questions were also used if needed. Information collected from the two surveys was compiled and presented at a workshop on 2LCP.

SURVEYS AND INTERVIEWS OF CONTRACTORS AND AGENCIES EXPERIENCE WITH 2LCP

A detailed 16 question survey was issued through Survey Monkey® to both domestic and European contractors, suppliers, researchers, and department of transportation personnel who were identified through a literature review as having experience with 2LCP. The survey was divided into five categories that covered general information of the respondent, mix design and material properties, construction, cost, and overall experience of 2LCP. Over 100 invitations were sent out. A total of 25 individuals responded and took the survey, including 8 through phone interviews.

A statistical analysis was performed based on information collected from survey A, and the results are presented in Table 16. As the number of representatives for each 2LCP project who participated the survey is very different, statistical analyses on project-specific information could be misleading. The statistical analysis presented, therefore, focused mainly on concerns and opinions regarding 2LCP. Project-specific information such as project size (lane-mile), traffic (average daily traffic [ADT]), pavement design, mix design, aggregate type and material properties was summarized and compiled with information collected from the literature review in a project-based manner and presented in Table 1.

As shown in the Table 16, the majority of respondents participating in the survey have over 16 years' experience in paving. The respondents were spread out in different fields, with 40,

32, and 24 percent from research, construction, and design, respectively. There was only one person from the equipment manufacturer or design category that participated in the survey. Regarding the major reasons for using 2LCP instead of traditional (single-lift) paving method, approximately half (44 percent) of the respondents stated that 2LCP practice was chosen for experimentation purpose. This result was expected since most of the personnel participating in the survey are from the United States, where 2LCP is still a relatively new concept. Surface characteristics counted for 28 percent of the answers. Many of the 2LCP projects used EAC in surface courses, which results in a lower noise level and allows better skid resistance on the pavement surface. EAC is a common practice in Europe and in many cases EAC is more economical to be placed using 2LCP. There are also cases where contractors were unable to achieve required ride quality with the single-layer practice. Approximately 13 percent of the answers referred to economics as the major reason, which is mostly due to the cost savings from being able to use higher amounts of local materials or lower amounts of cement, and/or the lower costs of the EAC surface due to the reduced thickness of the surface course. Some other reasons that 2LCP was selected are aggregate availability and sustainability considerations. Regarding areas attributed to the greatest impact to overall 2LCP project cost, the majority (66 percent) of respondents consider extra equipment as the main factor. Preplanning, unexpected expenditures, and extra manpower account for 13, 10, and 3 percent, respectively. Another 10 percent stated that the cost of 2LCP was significantly higher due to the higher bidding costs because of the small size of trial sections and inexperience of the contractor in 2LCP. Similar responses were found in question 10, with 73 percent considered preplanning as the most challenging of 2LCP to be overcome. Regarding the overall experience of 2LCP, about 60 percent stated good to excellent (45 percent good and 14 percent excellent). Forty-one percent chose a neutral opinion between worse and best. Nearly all respondents participating in the survey stated that they would like to participate in another 2LCP project. The two respondents who chose not to participate in another 2LCP project were either retired or stated that there is no new pavement construction. In regard to the opinion on the need for a 2LCP at this time, the answers were spread out between immediate need and no need at all. For those who chose “not a need for 2LCP at this time,” most stated that there will be a need within five years. Some additional comments regarding the need for 2LCP can be found in Table 17. Regarding the efforts needed from different aspects of 2LCP versus traditional paving methods, it shows that extra efforts are needed for most aspects.

Handling additional equipment, placing, and scheduling are the top three aspects that required additional efforts.

Table 16. Summary of Information Collected from Survey A.

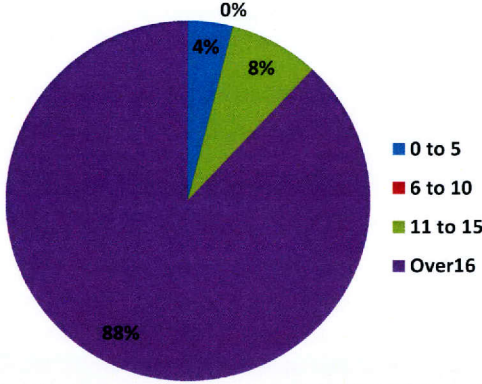
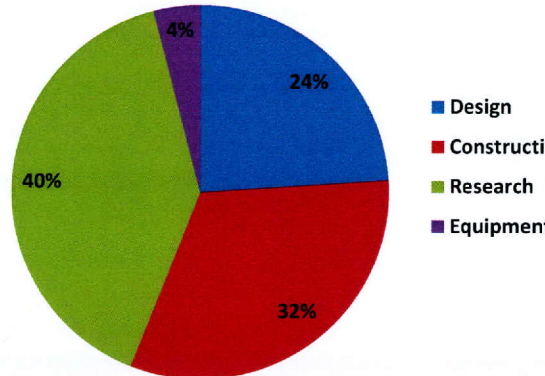
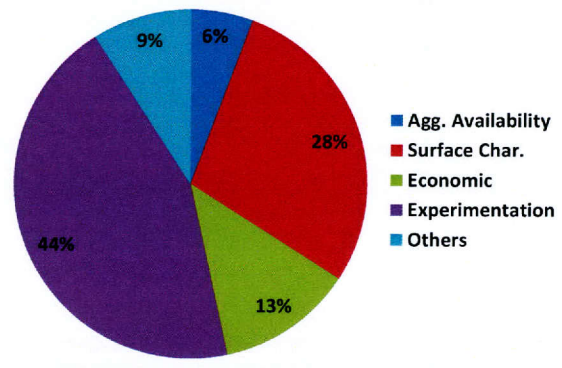
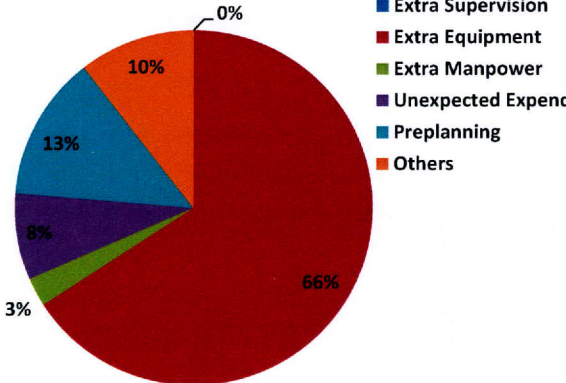
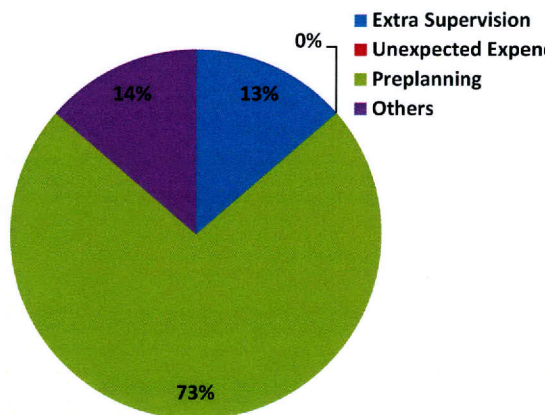
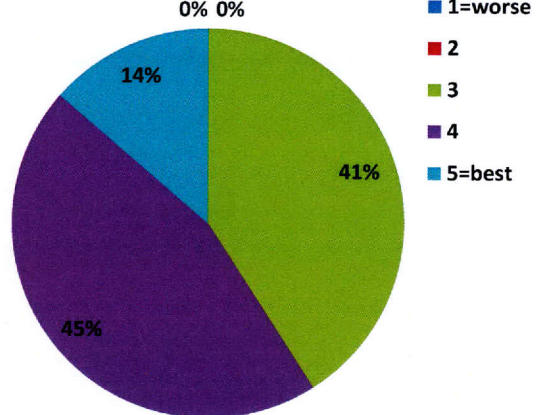
<p>Question2: How many years do you have with paving experience? (Results from 25 valid responses)</p>  <table border="1"> <thead> <tr> <th>Experience Range</th> <th>Percentage</th> </tr> </thead> <tbody> <tr> <td>0 to 5</td> <td>0%</td> </tr> <tr> <td>6 to 10</td> <td>4%</td> </tr> <tr> <td>11 to 15</td> <td>8%</td> </tr> <tr> <td>Over 16</td> <td>88%</td> </tr> </tbody> </table>	Experience Range	Percentage	0 to 5	0%	6 to 10	4%	11 to 15	8%	Over 16	88%	<p>Question3: Which of the following best describe your field of experience in paving? (Results from 25 valid responses)</p>  <table border="1"> <thead> <tr> <th>Field of Experience</th> <th>Percentage</th> </tr> </thead> <tbody> <tr> <td>Design</td> <td>24%</td> </tr> <tr> <td>Construction</td> <td>32%</td> </tr> <tr> <td>Research</td> <td>40%</td> </tr> <tr> <td>Equipment</td> <td>4%</td> </tr> </tbody> </table>	Field of Experience	Percentage	Design	24%	Construction	32%	Research	40%	Equipment	4%	<p>Question5: Major reason for using 2LCP vs. traditional paving? (Results from 22 valid responses)</p>  <table border="1"> <thead> <tr> <th>Reason</th> <th>Percentage</th> </tr> </thead> <tbody> <tr> <td>Agg. Availability</td> <td>28%</td> </tr> <tr> <td>Surface Char.</td> <td>13%</td> </tr> <tr> <td>Economic</td> <td>44%</td> </tr> <tr> <td>Experimentation</td> <td>9%</td> </tr> <tr> <td>Others</td> <td>6%</td> </tr> </tbody> </table>	Reason	Percentage	Agg. Availability	28%	Surface Char.	13%	Economic	44%	Experimentation	9%	Others	6%				
Experience Range	Percentage																																					
0 to 5	0%																																					
6 to 10	4%																																					
11 to 15	8%																																					
Over 16	88%																																					
Field of Experience	Percentage																																					
Design	24%																																					
Construction	32%																																					
Research	40%																																					
Equipment	4%																																					
Reason	Percentage																																					
Agg. Availability	28%																																					
Surface Char.	13%																																					
Economic	44%																																					
Experimentation	9%																																					
Others	6%																																					
<p>Question11: Which of the following attributed to the greatest impact to overall 2LCP project cost? (Results from 19 valid responses)</p>  <table border="1"> <thead> <tr> <th>Impact Factor</th> <th>Percentage</th> </tr> </thead> <tbody> <tr> <td>Extra Supervision</td> <td>13%</td> </tr> <tr> <td>Extra Equipment</td> <td>66%</td> </tr> <tr> <td>Extra Manpower</td> <td>3%</td> </tr> <tr> <td>Unexpected Expenditure</td> <td>8%</td> </tr> <tr> <td>Preplanning</td> <td>10%</td> </tr> <tr> <td>Others</td> <td>0%</td> </tr> </tbody> </table>	Impact Factor	Percentage	Extra Supervision	13%	Extra Equipment	66%	Extra Manpower	3%	Unexpected Expenditure	8%	Preplanning	10%	Others	0%	<p>Question10: Please identify the way(s) that challenges of 2LCP were overcome most. (Results from 22 valid responses)</p>  <table border="1"> <thead> <tr> <th>Challenge Overcome</th> <th>Percentage</th> </tr> </thead> <tbody> <tr> <td>Extra Supervision</td> <td>13%</td> </tr> <tr> <td>Unexpected Expenditure</td> <td>14%</td> </tr> <tr> <td>Preplanning</td> <td>73%</td> </tr> <tr> <td>Others</td> <td>0%</td> </tr> </tbody> </table>	Challenge Overcome	Percentage	Extra Supervision	13%	Unexpected Expenditure	14%	Preplanning	73%	Others	0%	<p>Question12: On a scale of 1-5 (1=worse and 5=best), please rate your overall experience with 2LCP (Results from 22 valid responses)</p>  <table border="1"> <thead> <tr> <th>Rating</th> <th>Percentage</th> </tr> </thead> <tbody> <tr> <td>1=worse</td> <td>0%</td> </tr> <tr> <td>2</td> <td>0%</td> </tr> <tr> <td>3</td> <td>41%</td> </tr> <tr> <td>4</td> <td>45%</td> </tr> <tr> <td>5=best</td> <td>14%</td> </tr> </tbody> </table>	Rating	Percentage	1=worse	0%	2	0%	3	41%	4	45%	5=best	14%
Impact Factor	Percentage																																					
Extra Supervision	13%																																					
Extra Equipment	66%																																					
Extra Manpower	3%																																					
Unexpected Expenditure	8%																																					
Preplanning	10%																																					
Others	0%																																					
Challenge Overcome	Percentage																																					
Extra Supervision	13%																																					
Unexpected Expenditure	14%																																					
Preplanning	73%																																					
Others	0%																																					
Rating	Percentage																																					
1=worse	0%																																					
2	0%																																					
3	41%																																					
4	45%																																					
5=best	14%																																					

Question13: Would you like to participate on another 2LCP project? (Results from 22 valid responses)

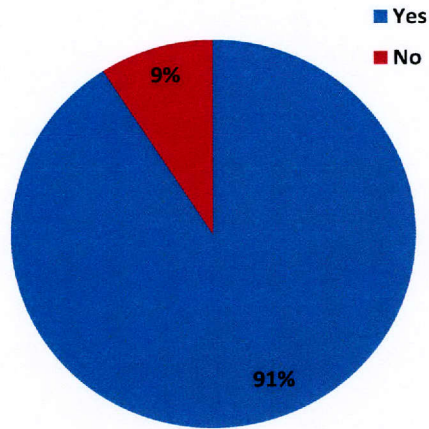

Question14: On a scale of 1-5 (1=immediate need and 5 = no need at all), please rate your opinion on need for a 2LCP at this time (Results from 22 valid responses)

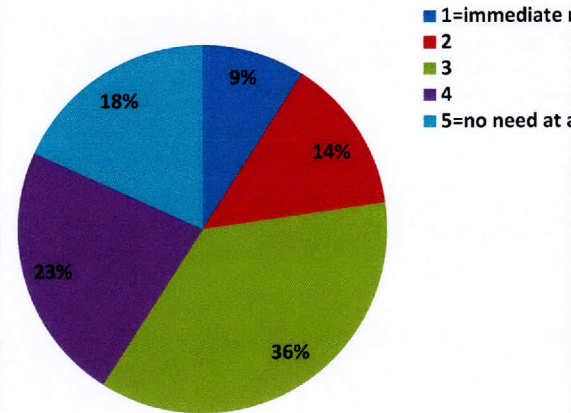

Question15: If you chose there is not a need for 2LCP at this time, when do you think there will be a need? (Results from 11 valid responses)

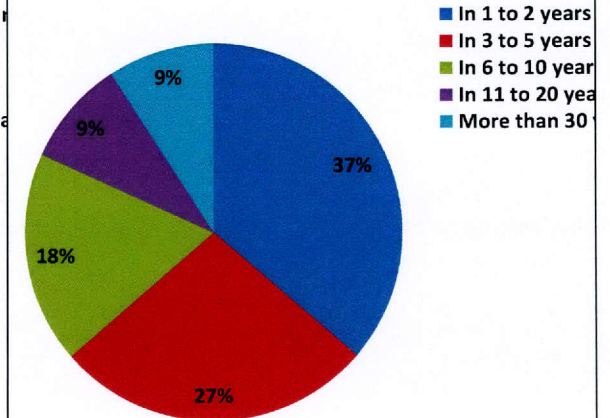

Question 9: Please rate the following aspects of 2LCP vs. traditional paving methods (Results from 24 valid responses)

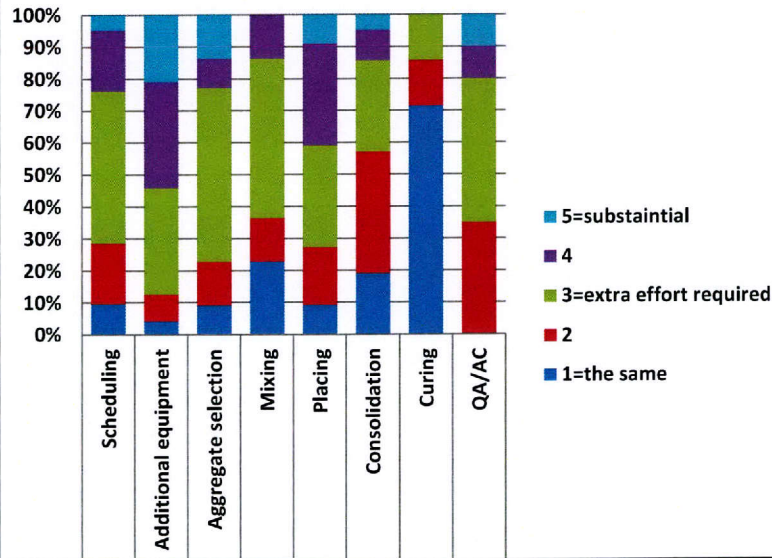

Table 17. Comments Regarding Needs for 2LCP.

Pros	<ul style="list-style-type: none"> <input type="checkbox"/> With the 2LCP it is possible to create a higher-quality concrete surfaces and the opportunity to recycle old concrete pavements. With the two layers you can use different consistencies between the upper and lower concrete. In Austria, we are convinced of this 2LCP method since decades. <input type="checkbox"/> Economy, sustainability, quality. <input type="checkbox"/> Higher priority needs at this time, but technology as technique has interest due to potential for sustainability benefits. <input type="checkbox"/> Better utilization of local aggregates or recycled aggregates; friction; reduced noise. Decrease in supply of high quality aggregate and higher transportation (trucking) costs. <input type="checkbox"/> Desirable to ensure most economic use of aggregate. <input type="checkbox"/> Needs grows with demand for sustainability.
Neutral	<ul style="list-style-type: none"> <input type="checkbox"/> Main reason is reduced noise level of fine exposed aggregate concrete. However, comparable noise levels have recently been met with a single layer concept of exposed aggregate concrete. So, the question is if it is worth facing the extra efforts and risks. <input type="checkbox"/> Depends on location and aggregate availability – it is something new that must also be accepted as an option.
Cons	<ul style="list-style-type: none"> <input type="checkbox"/> We are not building many new pavements, mostly rehabilitations. <input type="checkbox"/> North Carolina is fortunate to have very good quality aggregate available across most of the state. We have not felt the need for 2LCP. <input type="checkbox"/> Original reason is traffic noise nowadays we would make a concrete road with a silent asphalt topping. <input type="checkbox"/> Experience was mainly for skid resistance issue but up to now, we are disappointed even if we used hard aggregates. Need 2 sets of paving machine or special piece of kit. Since resistance asked of 35 MPa is pretty low, powerful brushing equipment for exposed aggregate cannot be used within 24 hrs so we have problems of uniformity of texture.

Additional comments collected through the survey are summarized in Table 18.

Table 18. Additional Comments Regarding 2LCP.

General	<ul style="list-style-type: none"> <input type="checkbox"/> Is it worth facing the risk and extra effort. <input type="checkbox"/> Choice is ultimately left to the Owner. <input type="checkbox"/> Project focused on noise reduction but noise is most often overcome today by placing an asphalt topping on concrete paving. <input type="checkbox"/> Performance based specs are favored by contractors, improves performance, prescriptive specs intro too much variation between parties and projects. <input type="checkbox"/> Seeking to construct “quiet pavement” (based on European experience) using surface lift with exposed aggregate treatment (Austria, Germany, and Spain). <input type="checkbox"/> Contractor unable to achieve required ride quality with single layer (Kessignland, Suffolk, England). <input type="checkbox"/> Improve Sustainability (Illinois Tollway).
Construction	<ul style="list-style-type: none"> <input type="checkbox"/> Sometimes it is difficult to unload both types of concrete in front of the paver in tunnels. <input type="checkbox"/> Inexperienced contractors’ ability to read specs. Prebid meeting or workshop. <input type="checkbox"/> Skid Resistant and EAC finish are difficult to achieve and require experienced contractors. <input type="checkbox"/> Productivity is increased because a single batch plant can produce more concrete than one spreader can place. <input type="checkbox"/> The crew should only increase by the number of operators and plant crew. Management, QC, and finishing should not increase. <input type="checkbox"/> 2 drum mixing plant may cause confusion. <input type="checkbox"/> Require different vibrating speeds for lifts. <input type="checkbox"/> Production rates are most important factor in US and not as much in Europe.
Cost	<ul style="list-style-type: none"> <input type="checkbox"/> The costs are much lower than 1LCP (Austria, Germany, and Spain). <input type="checkbox"/> Costs at MnRoad are difficult to use as a generalization because of small quantities, production. <input type="checkbox"/> Method is new and therefore higher bids are received and should be accepted as an option. <input type="checkbox"/> Aggregate and mixture evaluation contributed greatly to overall project cost. <input type="checkbox"/> Transportation of very hard aggregate. <input type="checkbox"/> No impact to construction cost. <input type="checkbox"/> 2LCP has seen 10–20% increase in cost vs. traditional. <input type="checkbox"/> The cost from the additional paver might not have that much of an impact due to the current economic condition, many contractors do not have their pavers in full use.

APPENDIX E SURVEY B QUESTIONS

(0-6742) Survey for Potential Two-Lift Paving (2LCP) Users

1. Please provide the following contact information so that we may contact you if we have further questions.

Name: _____
Organization: _____
Email Address: _____
Telephone: _____

2. How many years do you have with paving experience?

- 0-5
 6-10
 11-15
 Over 16

3. Which of the following best describe your field of experience in paving?

- Design
 Construction
 Research
 Equipment Manufacturer/Designer

Other (please specify)

_____ |

4. Experience with Two Lift Concrete Paving (2LCP)

- I have heard of it
 I am not familiar with this method
 I have participated on a previous project
 I would like the opportunity to participate

(0-6742) Survey for Potential Two-Lift Paving (2LCP) Users

5. Please identify major issues that you consider in implementing 2LCP
(note: may choose more than one).

- Constructability
- Increased cost
- Maintenance
- Material compatibility

Others (please specify)

6. Please identify your major concern with 2LCP
(note: may choose more than one).

- Constructability
- Increased cost
- Maintenance
- Material compatibility
- I do not have any major concerns with 2LCP

Others (please specify)

7. Please rate the following aspects as to the degree of concern you may have to implementing 2LCP.

(1 = no concern, 3 = moderate concern, 5 = strong concern):

	1	2	3	4	5
Scheduling	<input type="radio"/>	<input type="radio"/>	<input type="radio"/>	<input type="radio"/>	<input type="radio"/>
Additional Equipment	<input type="radio"/>	<input type="radio"/>	<input type="radio"/>	<input type="radio"/>	<input type="radio"/>
Aggregate Selection	<input type="radio"/>	<input type="radio"/>	<input type="radio"/>	<input type="radio"/>	<input type="radio"/>
Mixing	<input type="radio"/>	<input type="radio"/>	<input type="radio"/>	<input type="radio"/>	<input type="radio"/>
Placing	<input type="radio"/>	<input type="radio"/>	<input type="radio"/>	<input type="radio"/>	<input type="radio"/>
Consolidation	<input type="radio"/>	<input type="radio"/>	<input type="radio"/>	<input type="radio"/>	<input type="radio"/>
Curing	<input type="radio"/>	<input type="radio"/>	<input type="radio"/>	<input type="radio"/>	<input type="radio"/>
QA/QC	<input type="radio"/>	<input type="radio"/>	<input type="radio"/>	<input type="radio"/>	<input type="radio"/>

8. On a scale of 1-5 (1=not possible, 3=likely and 5=definitely), rate the likelihood of you in implementing 2LCP.

- 1 2 3 4 5

(0-6742) Survey for Potential Two-Lift Paving (2LCP) Users

9. On a scale of 1-5 (1=immediate need and 5 = no need at all), please rate your opinion on need for a 2LCP at this time.

- 1 2 3 4 5

Briefly explain why you make the above mentioned choice.

10. If you chose there is not a need for 2LCP at this time, when do you think there will be a need?

- In 1 to 2 years
 In 3 to 5 years
 In 6 to 10 years
 In 11 to 20 years
 In 21 to 30 years
 More than 30 years

11. Please provide any suggestions or comments for others interested in 2LCP.

12. Please list any person(s) who may you would suggest being contacted regarding the implementation of 2LCP.

APPENDIX F LIST OF PERSONNEL IN SURVEY B

Table 19. List of Personnel in Survey B.

Name	Affiliations
Chris Smith	Austin Bridge and Road
Stewart Krummen	C.S. McCrossan Construction
Rich Rogers	Cement council of Texas
Seth Schulgen	William brothers
Peter Taylor	CP Tech Center
Stan Allen	Ed Bell Construction Company
Kendrick Baros	Fordice Agg
Kevin Klein	Gomaco
Jim Abrams	JD Abram
Mark A. Smith	TxDOT Wichita Falls
buster sanders	TxDOT
Allan Moore	TxDOT
Billy S. Pigg	TxDOT
Cal Hays	TxDOT
Clifford Halvorsen	TxDOT
Doug Eichorst	TxDOT
Eliza Paul	TxDOT
Mike Bostic	TxDOT
Mike McAnally	TxDOT
Miles R Garrison, PE	TxDOT
Sarwar (Test)	TxDOT
Tom Hunter	TxDOT
Noel Paramanantham	TxDOT
Ruben Carrasco	TxDOT
Hua Chen	TxDOT
Andy Naranjo	TxDOT
Darlene Goehl	TxDOT - BRY
Richard Williammee, Andy Kissig, Paul Spraggins	TxDOT - FTW
Randy Hopmann	TxDOT - Tyler District
Gary Graham	TxDOT retired

APPENDIX G SURVEY B SUMMARY

The second survey (Survey B) for this project is focused on potential two-lift paving users including TxDOT personnel and pavement contractors. The survey was composed of 12 questions and covered background information of personnel, experience with 2LCP, concerns on implementing 2LCP, opinions on need for 2LCP, and the likelihood of implementing 2LCP. The research team contacted contractors and the TxDOT personnel from the larger urban districts and the Pavements and Materials and Tests in the TxDOT Construction Division for their initial inputs regarding concerns with 2LCP. An online survey was used as the primary method of response since phone calls were ineffective to obtain survey responses. A total of 32 responses were received.

Table 20. Summary of Information Collected from Survey B.

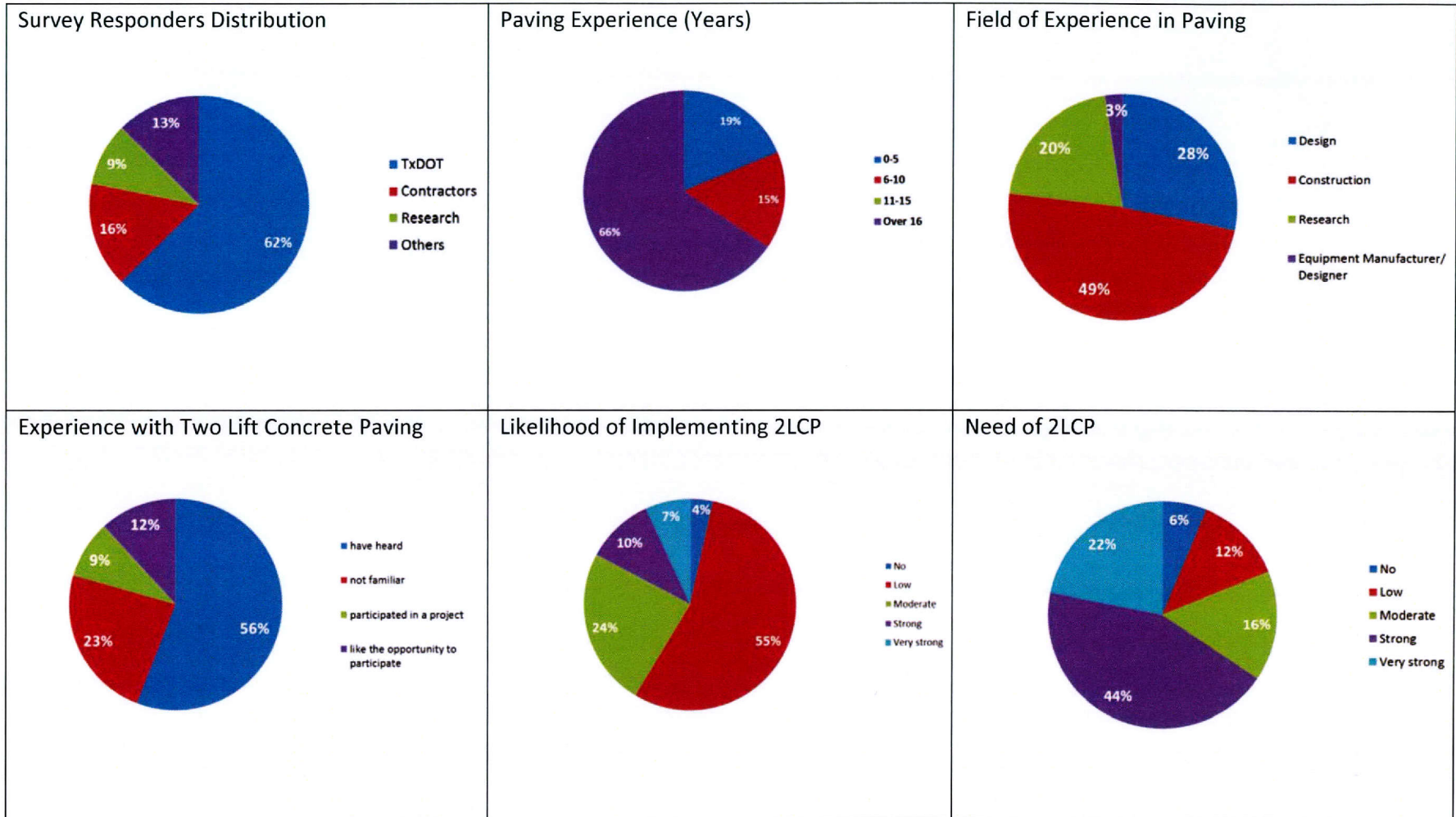

Major Issues to Implement 2LCP

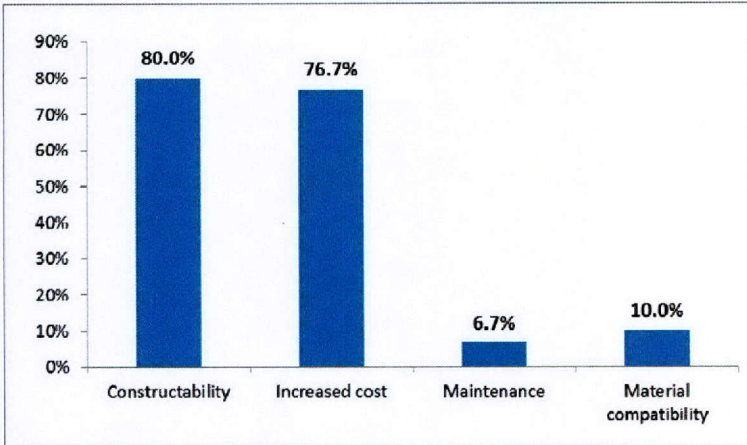

Major Concern with 2LCP

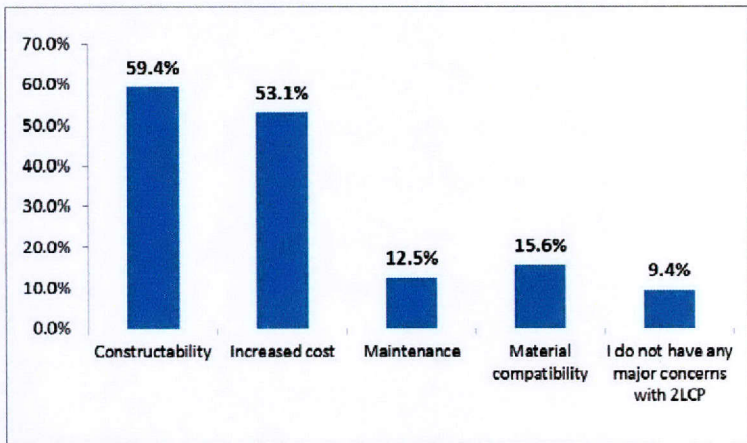

Degree of Concern of Various Aspects

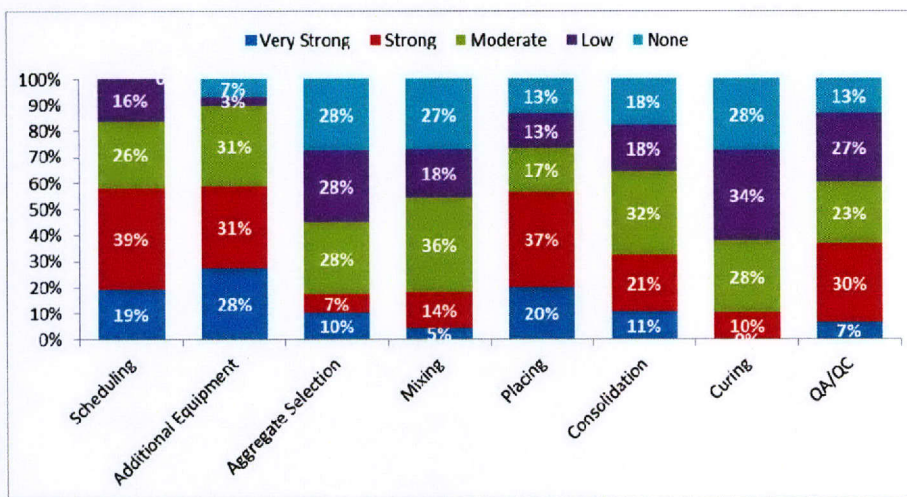

As shown in the Table 20, more than 50 percent of the respondents have over 16 years of experience. Approximately half of the respondents are experienced in construction followed by design and research. Only one equipment manufacturer participated in the survey. About 25 percent of the participants had never heard of 2LCP. About 55 percent had heard and 10 percent had participated in 2LCP projects. Constructability and increased cost are the two major concerns in implementing 2LCP. Respondents also selected additional labor and equipment and coordination of two batching plants as other potential concerns. Most of the survey takers have low to moderate likelihood of implementing 2LCP. Sixty-five percent of the participants indicate a strong to very strong need for 2LCP.

APPENDIX H WORKSHOP AGENDA

Two-Lift Paving Workshop Agenda **The Commons, Room 1.108, Pickle Research Campus** **10100 Burnet Road, Austin** **May 23, 2013**

8:30am Welcome and opening comments Jiong Hu, Darrin Jensen
 Self-introduction of attendees
 Background of project—Why two-lift paving? David Fowler
 Project Tasks Jiong Hu
 Findings from Tasks 1 and 2 Graduate students

9:15am Presentations

- TxDOT prospective—Andy Naranjo, TxDOT
- Introduction of two-lift paving—Peter Taylor, CP Tech Center
- Designers' viewpoints—Luc Rens, EuPave
- Environmental performance—Joep Meijer, The Right Environment
- Agency viewpoints—Shreenath Rao ARA, Illinois Tollway
- Contractors' viewpoints—Tim Gerhardt, Koss Construction
- Pavement equipment suppliers—Kevin Klein, Gomaco

12:00am Lunch with short presentations

- Two-lift paving research—Alex Brand, University of Illinois

1:00 pm Discussion of all attendees

3:30 pm Summary of major issues and findings David Fowler
 Action items Jiong Hu

4:00 pm Adjourn

For additional information contact:

Jiong Hu	David Fowler
Texas State University	The University of Texas at Austin
512 245 6328	512 232 2575
jiong.hu@txstate.edu	dwf@mail.utexas.edu

APPENDIX I SUMMARY OF WORKSHOP

A Two-Lift concrete Paving (2LCP) workshop was organized as a part of TxDOT project 0-6749: Feasibility Study of Two-Lift Concrete Paving (2LCP). This workshop was conducted at the J. J. Pickle Research Campus (PRC), The University of Texas, Austin, TX, on May 23, 2013. Dr. Jiong Hu, Texas State University, research supervisor, and Dr. David Fowler, The University of Texas at Austin, co-research supervisor, co-chaired the workshop. The workshop offered the option of attending in person or remotely through webinar. Fifty-one attendees were present remotely or in person, 28 in person and 23 persons remotely. The list of attendees is included in Appendix J. The workshop began with a welcome and opening comments followed by self-introduction of the attendees, background of the project, a brief presentation of the project tasks and findings. Presentations from 2LCP experts in the morning session were followed by general discussion in the afternoon session. The workshop agenda is included in Appendix H.

SUMMARY OF EXPERT PRESENTATIONS

Two-Lift Concrete Paving TxDOT Perspective: Andy Naranjo, TxDOT Construction Materials and Pavements Division

Some high volume concrete pavement districts of Texas lack good quality aggregate sources for concrete pavements. The Dallas and Fort Worth Districts do not have sufficient sources of locally available good quality natural sand. Local manufactured fine aggregate in the Dallas and Fort Worth Districts, primarily carbonate, is unable to meet the minimum acid insoluble (A.I.) of 60 percent, which limits the use of manufactured sand. These districts will need to transport natural sand from longer distances if other solutions cannot be found. Other districts that have siliceous river gravel aggregates that are unable to meet the TxDOT maximum CoTE value for use in continuously reinforced concrete pavements must import suitable aggregates. Research projects funded by TxDOT have shown that thermal incompatibility between aggregate and cement paste is one of the reasons for these distresses. Spalling has been virtually eliminated since the Houston District started to use low CoTE aggregate in the CRCP. Recently TxDOT adopted a CoTE of 5.5×10^{-6} in/in/°F for concrete as a qualifying criterion for coarse aggregate of CRCP. About 75 percent of TxDOT qualified aggregate suppliers meet the limit. However, some districts such as Houston and Beaumont do not have locally available low CoTE must transport low CoTE aggregate from longer distances.

2LCP can help alleviate the effects of those problems by using locally available materials in thicker bottom lifts and high quality materials in thinner top lift. 2LCP will help to conserve the good quality materials and allow other materials to be used in concrete pavement construction.

Two-Lift Paving an Overview: Dr. Peter Taylor, CP Tech Center

Two-lift concrete paving is constructed by placing two layers of concrete. Generally, the bottom layer (commonly referred as bottom lift) consists of lower quality concrete. Typically, lean concrete with high SCMs content is used in bottom-lifts. Locally available aggregates, which are not suitable for surface use, are the common choices for bottom lifts. The use of recycled aggregates in bottom lifts is also a common practice due to the sustainability and economy of the pavement construction. High quality materials are used in the top layer (commonly referred as top lift). The top lift is generally the thinner of the two layers. As a result a lower volume of high quality concrete is needed. A high quality top lift provides better durability and skid resistance. 2LCP is constructed as wet-on-wet concrete that not only helps to achieve better bonding between the layers, but it also reduces the differential shrinkage problem. Benefits of 2LCP include: (1) low environmental impact and special environmental friendly materials can be used such as TiO_2 and (2) though initial cost of 2LCP construction is higher, life cycle costs are usually lower. The learning process to construct 2LCP and lack of specifications are two major reasons that hinder the implementation of 2LCP in the U.S.

Two-Lift Paving Design Aspects: Luc Rens, EUPAVE

Belgium has previous experience in 2LCP construction in 1996 and 2002. The objectives of constructing 2LCP CRCP pavement over conventional CRCP are to reduce pavement noise by use of exposed aggregate finish on the surface and to use recycled aggregate from the existing pavement in the bottom-lift. Typically a lean mixture of concrete is used in bottom lift at a thickness ranging from 6 to 8 in. The top-lift is thinner, ranging from 2 to 3 in., but richer concrete is used. Concrete layers are placed wet-on-wet. The typical time interval between layers varies from 30 minutes to 2 hours. A 30-minute time interval is the most preferable. After three years of service severe cracks were observed. However, separation was observed at the top and bottom layer interface. Delamination occurred at the level of reinforcement. Use of recycled

aggregates is thought to be the cause of pavement distresses. No data on the CoTE of concrete were available, which can be another reason of the distresses. To avoid these types of distresses, no recycled aggregate was allowed in a recent 2LCP project in 2012.

Environmental Benefits of Two-Lift Pavement: Joep Meijer, The Right Environment Ltd. Co.

This presentation covered the life cycle assessment (LCA) of 2LCP. LCA is a powerful tool to assess the environmental performance of products, services, or scenarios. It is based on the material and energy flows of processes and materials that together form a lifecycle. LCA assesses the impact of global warming, depletion of non-renewables, depletion of ozone layer, acidification, eutrophication, summer smog, aquatic echo toxicity, terrestrial echo toxicity, human toxicity, energy, non-hazardous waste, and hazardous waste. Three different pavement types were used in a Kansas project: traditional, two-lift, and optimized two-lift. Two-lane (12 ft wide lane) 0.62-mile jointed concrete pavements (JCP) were made using the Kansas Department of Transportation (KDOT) specification. Traditional pavement aggregates were obtained from Oklahoma. No SCMs were used with portland cement. For two-lift pavement, recycled aggregate was used in cement treated base (CTB), and fly ash was partly used in both CTB and top lift. Optimized 2LCP had similar material use as 2LCP; in addition, recycled aggregate and fly ash were used in the bottom lift. Data necessary to perform LCA analysis were obtained from average European data because of the unavailability of U.S. data. Optimized 2LCP performed best in LCA analysis followed by 2LCP and conventional JCP.

Two Lift Concrete Composite Pavements: Dr. Shreenath Rao, Applied Research Associates, Inc.

The Illinois Tollway has been constructing two-lift jointed concrete pavement since the late '50s. Illinois Tollway is interested in 2LCP because of sustainability, economy, social, and environmental reasons. 2LCP gives an opportunity to recycle the aggregate obtained from existing pavements. Before using recycled aggregates in 2LCP bottom lift, they were used as base material. Fractionated recycled asphalt pavement (FRAP) has recently been used in 2LCP because of its wide availability. Reconstruction of old asphalt pavements have led to the wide availability of fractionated recycled asphalt pavement (FRAP). This in turn has resulted in the increased use of FRAP in 2LCP. Illinois Tollway with help from universities developed the limit

for FRAP ternary concrete mixtures. Further research on the use of FRAP concrete in the bottom lift of 2LCP was done to determine the pavement thickness requirement. The final outcome showed that a weaker bottom lift does not warrant the need for a thicker pavement. The reasons the Tollway is doing 2LCP projects: (1) improved sustainability with more recycling (with FRAP in particular and the option for recycled coarse aggregate (RCA) in the bottom lifts), (2) use of SCMs in pavement mixes (for both lifts), and (3) freedom given to the contractor/supplier to optimize all pavement mixtures and reduce cement content in all mixes (for both lifts). Some key provisions of current specifications of bottom lift concrete by Illinois Department of Transportation (IDOT) are optimized gradation, 15 percent to 50 percent; coarse FRAP, 0 percent to 85 percent; coarse RCA; ternary mixes are required; and blended cements are allowed. Additional research is being done to improve the current specification. Research includes use of coarse FRAP from IDOT mix sources; use of lower quality virgin aggregates; and use of aged/oxidized steel slag FRAP. Performance of 2LCP can be improved by reducing the permeability, mitigating ASR concerns, improving durability with ternary mixes, reducing noise, improving surface friction, better control on smoothness, use of pervious concrete for permeable concrete, and use of photo-catalytic cements to reduce pollution. Test strips are placed for all types of pavement construction (single or two lift). At the start of each single- and double-lane placement, 300 ft long strips were placed. Cores are taken and MIT scans are done to verify consolidation, thickness, good bond, and dowel alignment. Time interval between two layers is no more than 45 minutes and no more than 150 ft in distance. The current specifications require two slip form pavers and two belt placers to be used for both lifts unless the contractor can prove that alternative placement methods, for the bottom lift in particular, can be allowed for specified dowel alignment, and suitable consolidation under dowel bars can be obtained. All two lift pavements must be tined longitudinally.

The rules for opening to either construction traffic or public traffic differ due to the lower flexural and compressive strengths expected for the bottom lift recycled aggregate ternary mixes at early ages. The current limits were based on two-lift precast slab load tests performed at the University of Illinois and are as follows.

For opening to construction traffic:

- Seven-day cure unless strength tests are performed.
- Specimens for both lifts must reach a minimum three-point flexural strength of 450 psi and a compressive strength of 2,850 psi at an age of not less than 5 days.

For opening to public traffic:

- Twenty-eight day cure unless strength tests are performed.
- Top lift specimens must reach a minimum flexural strength of 650 psi and a compressive strength of 3,500 psi at an age of not less than 14 days.
- Bottom lift specimens must reach a minimum flexural strength of 575 psi and a compressive strength of 3,200 psi at an age of no less than 14 days.

2LCP pavement with FRAP concrete seems to be cheaper than single-lift pavement with regular concrete.

Two-Lift Paving Contractor's Perspective: Tim Gerhardt, Koss Construction Company

Construction of 2LCP is getting attention due to three important reasons: air void problems, quality of local aggregates, and extended pavement life. Koss Construction Company was involved in constructing 2LCP on I-70, Salina, Kansas. The west bound lane was built in 2007 and the east bound lane was built in 2008. It was two 12-ft lanes of jointed concrete pavement with uniform shoulders on variable granular base. Stiffness of the bottom lift and durability of the top lift concrete were critical. No-slump concrete was used for the bottom lift, and the material was delivered through a haul road beside the paver. Top-lift delivery and placement technique was selected to achieve minimum bottom-lift deformation. Test sections were built before the actual job. The test section was built in Linn County, Kansas, on US 69. A haul road was used on each side of the constructed test sections. One belt placer in conjunction with a paver was used to place the concrete. Two vibrators were used to achieve the desired consolidation. The test section was broomed to achieve the exposed aggregate surface. However, it was difficult to remove the mortar without applying water at the surface. Two different batch plants were used to produce top and bottom lift concrete. For the actual 2LCP project on I-70, a dual drum batch plant was used to produce concrete for both lifts. A color code was used to deliver the concrete to each paver. Low-slump concrete was desirable to achieve higher

production. If the slump was less than 1 in., the top-lift was placed in an efficient manner. Slump of the top-lift was 3-in. maximum. It was easier to compact and finish the top lift.

Two-Lift Concrete Paving Equipment Perspective: Kevin Klein, Gomaco

Gomaco has been working with 2LCP equipment for a long time. The single paver two-lift paving system was patented by Gomaco January 1976. This is a two chamber approach, where both the chambers are fed with concrete and each chamber can lay and compact the concrete independently. Gomaco also did some investigation on the dowel insertion technique for two-lift pavement, with the objective of achieving a vibration technique to avoid voids under dowel bars. North American concrete mixture design was used for the study. Both top and bottom-lift concrete had high aggregate fractions. But while pushing the dowel from top layer to bottom layer, the bottom layer material was pushed up at the top layer and the top layer thickness became uneven. Gomaco participated in a European style two-lift JCP project at 1993 in Detroit. A 7½-in. bottom lift and a 2½-in. top lift were used. The bottom lift was placed by a spreader, dowel bars were then inserted in the bottom layer, and finally the top-lift concrete was placed with a paver. In 1997, Gomaco participated in a 2LCP CRCP project near Newport, Wales, United Kingdom. This project used a 1.6-in. top-lift with a 3/8-in. maximum size aggregate. The thinner top-lift produced crumbly edge. As a result, workers had to refinish the edge to get a smooth and square edge. A single wet batch plant was used to produce the concrete mixtures. The concrete for top and bottom-lift mixing has to be controlled very well, for every three trucks of bottom lift concrete, one truck of top lift concrete had to be produced. Gomaco developed software to synchronize the truck load size and the travel time of each truck to achieve an efficient operation. In 2004, Skanska purchased a 150-ft paver to produce 2LCP in the Czech Republic. This paver has 3D machine control. A vibrator was placed perpendicularly at the front of the spreader. Vibration of top lift can be controlled to achieve excellent compaction without mixing the concrete of two layers.

Fractionated Reclaimed Asphalt Pavement (FRAP) in Concrete Slabs: Alexander S. Brand, University of Illinois at Urbana-Champaign

FRAP is obtained from the milled asphalt pavement. Coarse and fine aggregates are separated using a #4 sieve. Agglomeration greater than 1/2 or 5/8 in. was rejected. Illinois Tollway used FRAP for their 2LCP project. The Tollway used #4 and smaller FRAP as liquid

binder replacement with reclaimed asphalt shingles (RAS). The larger stockpile of coarse FRAP remain unused; these larger aggregates were used in the 2LCP project. This use of coarse FRAP in 2LCP is economical, sustainable use of aggregates, and reduces the carbon footprint. A ternary blend was used with 25 percent slag and 10 percent class C fly ash replacement. Cement content was 630 lb/yd³. Water-to-cementitious material ratio (w/cm) was 0.37. Coarse FRAP replacements of 0, 20, 35, and 50 percent were studied. Water reducing and air entraining admixtures were also used. Compressive strength, flexural strength, elastic modulus, and dynamic modulus were reduced for FRAP replaced concrete. However, total fracture energy remained statistically the same. Concrete with up to 50 percent FRAP replacement met the IDOT strength requirement. Large scale slab testing was also done using a slab size of 6-ft × 6-ft, a 4-in. bottom lift and a 2-in. top lift. Bottom-lift concrete was made from FRAP and the top lift used conventional concrete. Compressive strength, flexural strength, and the elastic modulus of recycled concrete was lower than for the conventional concrete. Fracture energy of recycled concrete and conventional concrete were statistically similar. However, the bottom lift with recycled aggregate had a higher effective failure stress than the full-depth conventional concrete slab.

General Discussion

In the general discussion session various aspects of 2LCP were discussed. Materials, constructability, equipment, design, and economy of 2LCP were main topics of discussion. The key points of the discussion are as follows:

- Most of the 2LCP are jointed pavement. In the U.S., no CRCP 2LCP has been constructed. It is a challenge to translate experience of jointed 2LCP to CRCP 2LCP. This problem can be overcome by more research and by constructing test sections.
- 2LCP is the choice of the near future due to the depletion of good quality aggregate sources.
- 2LCP is not a time saving process.
- Placement of two layers of steel depends on the thickness of the pavement. If the bottom lift is thick enough both layers of reinforcement can be placed in the bottom lift; otherwise one reinforcement layer has to be placed in the top lift.

- Aggregate blending is possible in 2LCP. CoTE of concrete can be reduced by blending low CoTE aggregate with high CoTE aggregate.
- Although there is no known study of potential debonding issues associate with the two different CoTE from the two different lifts, field and modeling studies show no debonding issue on bonded concrete overlay.
- A top-lift thickness of 1.6-in. was successfully constructed. Top-lift thickness should be designed based on the grinding requirement, CoTE of concrete, and use of pollution absorbent material (such as TiO₂).
- There is no specification on bond strength between the top and bottom lifts of concrete. Bond strength between two layers needs to be specified. Ninety minutes or less time-lag between the placements of the two lifts is generally sufficient to achieve good bond for wet-on-wet placement.
- For bidding purposes, 2LCP should be an option rather than mandatory.
- The time lag between two layers placement is very important in terms of achieving good bond. But there are other factors that should be considered while selecting time lag. These factors include wind speed, temperature, relative humidity, and requirements of the contractor.
- Two pavers are popular in the U.S. for 2LCP construction, because lack of 2LCP projects and more flexibility while using two pavers.
- It is possible to use pervious concrete in 2LCP.
- Further research is needed on bond strength and time lag between the two lifts.

APPENDIX J LIST OF WORKSHOP ATTENDEES

Table 21. List of in Person Attendees of the 2LCP Workshop.

Name	Email	Organization
Alexander Sebastian Brand	abrand2@illinois.edu	University of Illinois
Ali AlQarni	aalqarni@ksu.edu.sa	The University of Texas
Andy Naranjo	Andy.Naranjo@txdot.gov	TxDOT
Chris Clement	chris.clement.755@gmail.com	The University of Texas
Darrin Jensen	darrin.jensen@txdot.gov	TxDOT RTI
David W. Fowler	dwf@mail.utexas.edu	The University of Texas
David Whitney	dpwhitney@mail.utexas.edu	The University of Texas
Gary Graham	gary.graham.mail@gmail.com	TxDOT retiree
Gerald D Lankes	gdlankes@sbcglobal.net	TCPA
Hua Chen	hua.chen@txdot.gov	TxDOT- Material Division
Jaime Gandara	Jaime.Gandara@txdot.gov	TxDOT
Jan Prusinski	hprusinski@cementx.org	Cement Council of Texas
Jim Abrams	JimAbrams@jdabrams.com	
Jim Travis	james.travis@fhwa.dot.gov	FHWA
Jiong Hu	jiong.hu@txstate.edu	Texas State University
Joep Meijer	joepmeijer@therightenvironment.net	The Right environment Ltd. Co.
Kendrick Baros	kendrick@fordyceco.com	Fordice
Kevin Klein	klein@gomaco.com	GOMACO Corp.
Md Sarwar Siddiqui	mssiddiqui@utexas.edu	The University of Texas
Michael R. Grams	mg1320@txstate.edu	Texas State University
Moon Won	moon.won@ttu.edu	Texas Tech University
Noel Paramanantham	Noel.Paramanantham@txdot.gov	TxDOT
Rich Rogers	rrogers@cementx.org	Cement Council of Texas
Richard Williammee	Richard.Williammee@txdot.gov	TxDOT- Dallas
Ruben Carrasco	Ruben.Carrasco@txdot.gov	TxDOT
Shreenath Rao	Srao@ara.com	Applied Research Associates, Inc.
Sherian Williams-Watson	sdwilliams@mail.utexas.edu	The University of Texas
Michael Rung	mrung@mail.utexas.edu	The University of Texas

Table 22. List of Remote Attendees of the 2LCP Workshop.

Name	Email	Organization
Billy Pigg	Billy.Pigg@txdot.gov	TxDOT- Waco
Brett Haggerty	Brett.Haggerty@txdot.gov	TxDOT
Cal Hays	Cal.Hays@txdot.gov	TxDOT
Chuck Ekleberry	Chuck.Ekleberry@gcinc.com	
Darlene Goehl	darlene.goehl@txdot.gov	TxDOT- Bryan
Dough Beer	Doug.Beer@txdot.gov	TxDOT-Wichita Falls
Eliza Paul	Eliza.Paul@txdot.gov	TxDOT-Houston
Gary Fick	glick@trinity-cms.com	Trinity Construction
Gina Ahlstrom	gina.ahlstrom@dot.gov	FHWA
Heather Mcleod	-	
Houston District Construction Division	-	TxDOT
Jim Mack	-	
Luc Rens	lrens@febelcem.be	EUPAVE
Mauricio Ruiz	-	Transtec
Miles Garrison	miles.garrison@txdot.gov	TxDOT-Atlanta
Peter Taylor	ptaylor@iastate.edu	CP Tech Center
Richard Meininger	Richard.Meininger@dot.gov	FHWA Agg./Petrographic Lab
Robert Rodden	rrodde@pavement.com	ACPA
Rod Montney	rodne@ksdot.org	KDOT
Sean Foley	Sean.Foley@martinmarietta.com	Martin Marietta Materials
Seth Schulgen	-	Williams brothers Const.
Tim Gerhardt	twg@kossconstruction.com	Koss Construction
Tomas Saenz	Tomas.Saenz@txdot.gov	TxDOT

APPENDIX K WORKSHOP EXIT SURVEY SUMMARY

An exit survey was taken at the end of the workshop and fourteen attendees participated.

A summary of the exit survey is as follows.

Table 23. Summary of the Exit Survey of the 2LCP Workshop.

Exit survey questions Please write your opinion to the following questions:	Summary of the exit survey results
1. Does this workshop satisfy your expectation?	All the participants responded that the workshop satisfied their needs.
2. Did you get an improved understanding of two-lift concrete paving by attending this workshop?	All the participants responded that the workshop improved their understanding of 2LCP.
3. What other two-lift concrete paving-related issues need to be addressed which were not covered in the workshop?	Participants pointed several issues that need more attention such as: specifications, use of recycled materials, 2LCP life cycle cost, thickness of low-lift with recycled aggregate, maintenance issues, ride quality, and inspection for quality control for each layer.
4. What are the issues that need to be considered/solved for implementing two-lift concrete paving in Texas?	These are the issues that need to be solved before implementing a 2LCP project in Texas: specifications, tolerances, material quality, ride quality, noise issues, constructability, funding, better workable mixture design, 2LCP life cycle cost, design thickness, contractors experience with 2LCP, and time lag between two-lift in Texas.
5. In your opinion, does two-lift paving make sense for some areas of Texas?	93% attendees think that 2LCP makes sense to some parts of Texas.
6. For TxDOT representatives, are you interested in further investigating or implementing two-lift paving in your district?	All the TxDOT representatives showed their interest in further investigation and implementation of 2LCP.

**Texas State University – San Marcos
The Texas State University System
San Marcos, Texas 78666-4684
and
Center for Transportation Research
The University of Texas at Austin
3208 Red River, Suite 200
Austin, Texas 78705-2650**