



Temporary Large Guide Signs

Technical Report 0-6782-1

Cooperative Research Program

TEXAS A&M TRANSPORTATION INSTITUTE
COLLEGE STATION, TEXAS

in cooperation with the
Federal Highway Administration and the
Texas Department of Transportation
<http://tti.tamu.edu/documents/0-6782-1.pdf>

1. Report No. FHWA/TX-13/0-6782-1		2. Government Accession No.		3. Recipient's Catalog No.	
4. Title and Subtitle TEMPORARY LARGE GUIDE SIGNS				5. Report Date Published: May 2014	
				6. Performing Organization Code	
7. Author(s) Roger P. Bligh, Dusty R. Arrington, and Wanda L. Menges				8. Performing Organization Report No. Test Report No. 0-6782-1	
9. Performing Organization Name and Address Texas Transportation Institute Proving Ground The Texas A&M University System College Station, Texas 77843-3135				10. Work Unit No. (TRAIS)	
				11. Contract or Grant No. Project 0-6782	
12. Sponsoring Agency Name and Address Texas Department of Transportation Research and Technology Implementation Office 125 E. 11 th Street Austin, Texas 78701-2483				13. Type of Report and Period Covered Test Report: August 2012–August 2013	
				14. Sponsoring Agency Code	
15. Supplementary Notes Project performed in cooperation with the Texas Department of Transportation and the Federal Highway Administration. Project Title: Development of Design Standards for Mounting Temporary Large Guide Signs URL: http://tti.tamu.edu/documents/0-6782-1.pdf					
16. Abstract <p>A common issue during phased highway construction projects is the need to temporarily relocate large guide signs on the roadside or install new guide signs for temporary use. The conventional concrete foundations used for these signs are costly and time consuming to install and remove after construction is completed.</p> <p>Direct embed wood and steel post support systems for temporary large guide signs were developed and successfully crash tested in accordance with <i>MASH</i> guidelines. The designs considered wind loads, foundation requirements, and impact performance. The direct embedded support posts eliminate the need for reinforced concrete foundations.</p> <p>The results of the research can be used to establish acceptance of other less critical design configurations for other sizes of temporary guide signs. Variations include different post size, grade, and spacing.</p>					
17. Key Words Breakaway Support, Sign Support, Guide Sign, Crash Testing, Roadside Safety			18. Distribution Statement No restrictions. This document is available to the public through NTIS: National Technical Information Service Alexandria, Virginia 22312 http://www.ntis.gov		
19. Security Classif.(of this report) Unclassified		20. Security Classif.(of this page) Unclassified		21. No. of Pages 160	22. Price

TEMPORARY LARGE GUIDE SIGNS

by

Roger P. Bligh, P.E.
Research Engineer
Texas A&M Transportation Institute

Dusty R. Arrington
Engineering Research Associate
Texas A&M Transportation Institute

and

Wanda L. Menges
Research Specialist
Texas A&M Transportation Institute

Report 0-6782-1

Project 0-6782

Project Title: Development of Design Standards for Mounting Temporary Large Guide Signs

Performed in cooperation with the
Texas Department of Transportation
and the
Federal Highway Administration

Published: May 2014

TEXAS A&M TRANSPORTATION INSTITUTE
College Station, Texas 77843-3135

DISCLAIMER

This research was performed in cooperation with the Texas Department of Transportation (TxDOT), and the Federal Highway Administration (FHWA). The contents of this report reflect the views of the authors, who are responsible for the facts and the accuracy of the data presented herein. The contents do not necessarily reflect the official view or policies of the FHWA or TxDOT. This report does not constitute a standard, specification, or regulation, and its contents are not intended for construction, bidding, or permit purposes. In addition, the above listed agencies assume no liability for its contents or use thereof. The United States Government and the State of Texas do not endorse products or manufacturers. Trade or manufacturers' names appear herein solely because they are considered essential to the object of this report. The engineer in charge of the project was Roger P. Bligh, P.E. (Texas, #78550).

TTI PROVING GROUND DISCLAIMER

The results of the crash testing reported herein apply only to the article being tested.

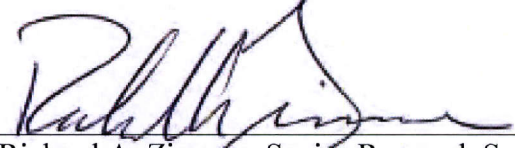

Wanda L. Menges, Research Specialist
Deputy Quality Manager

Richard A. Zimmer, Senior Research Specialist
Test Facility Manager
Quality Manager
Technical Manager

ACKNOWLEDGMENTS

This research project was conducted under a cooperative research program between the Texas A&M Transportation Institute (TTI), the Texas Department of Transportation (TxDOT), and the U.S. Department of Transportation, Federal Highway Administration. Cary Choate, with the TxDOT Research and Technology Implementation Office, served as the project manager. Members of the Project Management Committee included Jeremy Dearing (Lubbock District), Guillermo Dougherty (Laredo District), Carlos Ibarra (Atlanta District), Jesus Leal (Pharr District), Doug Skowronek (Traffic Operations Division), and Gary Tarter (Traffic Operations Division). These individuals were actively involved in all aspects of this research, and the authors acknowledge and appreciate their invaluable guidance and assistance.

TABLE OF CONTENTS

	Page
LIST OF FIGURES	x
LIST OF TABLES	xiii
CHAPTER 1. INTRODUCTION	1
1.1 INTRODUCTION	1
1.2 OBJECTIVES/SCOPE OF RESEARCH	1
CHAPTER 2. DIRECT EMBEDMENT WOOD SUPPORT SYSTEM.....	3
2.1 SUPPORT SELECTION	3
2.2 WIND LOAD ANALYSIS.....	4
2.3 POST ACTIVATION BELOW SIGN PANEL.....	6
2.4 FOUNDATION DESIGN.....	7
2.5 SIGN SUBSTRATE CONNECTIONS	10
2.6 CRASHWORTHINESS	11
CHAPTER 3. <i>MASH</i> CRASH TEST REQUIREMENTS AND PROCEDURES	15
3.1 TEST FACILITY	15
3.2 CRASH TEST MATRIX.....	15
3.3 EVALUATION CRITERIA	16
3.4 VEHICLE TOW AND GUIDANCE PROCEDURES.....	16
3.5 DATA ACQUISITION SYSTEMS.....	16
3.5.1 Vehicle Instrumentation and Data Processing	16
3.5.2 Anthropomorphic Dummy Instrumentation	17
3.5.3 Photographic Instrumentation and Data Processing	17
CHAPTER 4. CRASH TEST RESULTS for DIRECT EMBEDDED WOOD SUPPORT TEMPORARY GUIDE SIGN SYSTEM	19
4.1 TEST ARTICLE DESIGN AND CONSTRUCTION.....	19
4.2 <i>MASH</i> TEST 3-60 ON THE DIRECT EMBEDDED WOOD SUPPORT TEMPORARY GUIDE SIGN SYSTEM (TEST NO. 467823-1).....	21
4.2.1 Test Designation and Actual Impact Conditions	21
4.2.2 Test Vehicle	21
4.2.3 Weather and Soil Conditions	21
4.2.4 Test Description	22
4.2.5 Damage to Test Installation	22
4.2.6 Vehicle Damage.....	22
4.2.7 Occupant Risk Factors	23
4.2.8 Assessment of Test Results.....	25
4.2.8.1 Structural Adequacy.....	25
4.2.8.2 Occupant Risk.....	25
4.2.8.3 Vehicle Trajectory	26
4.3 <i>MASH</i> TEST 3-61 ON THE DIRECT EMBEDDED WOOD SUPPORT TEMPORARY GUIDE SIGN SYSTEM (TEST NO. 467823-2).....	26
4.3.1 Test Designation and Actual Impact Conditions	26
4.3.2 Test Vehicle	26
4.3.3 Weather and Soil Conditions	27

4.3.4	Test Description	27
4.3.5	Damage to Test Installation	27
4.3.6	Vehicle Damage	27
4.3.7	Occupant Risk Factors	28
4.3.8	Assessment of Test Results.....	29
4.3.8.1	Structural Adequacy.....	29
4.3.8.2	Occupant Risk.....	29
5.3.8.3	Vehicle Trajectory	31
4.4	DESIGN MODIFICATION.....	31
4.5	<i>MASH</i> TEST 3-61 ON THE MODIFIED DIRECT EMBEDDED WOOD SUPPORT TEMPORARY GUIDE SIGN SYSTEM (TEST NO. 467823-2b).....	34
4.5.1	Test Designation and Actual Impact Conditions	34
4.5.2	Test Vehicle	34
4.5.3	Weather and Soil Conditions	34
4.5.4	Test Description.....	35
4.5.5	Damage to Test Installation	35
4.5.6	Vehicle Damage.....	36
4.5.7	Occupant Risk Factors	36
4.5.8	Assessment of Test Results.....	37
4.5.8.1	Structural Adequacy.....	37
4.5.8.2	Occupant Risk.....	37
4.5.8.3	Vehicle Trajectory	39
4.6	<i>MASH</i> TEST 3-62 ON THE MODIFIED DIRECT EMBEDDED WOOD SUPPORT TEMPORARY GUIDE SIGN SYSTEM (TEST NO. 467823-3).....	39
4.6.1	Test Designation and Actual Impact Conditions	39
4.6.2	Test Vehicle	39
4.6.3	Weather and Soil Conditions	40
4.6.4	Test Description.....	40
4.6.5	Damage to Test Installation	41
4.6.6	Vehicle Damage.....	41
4.6.7	Occupant Risk Factors	42
4.6.8	Assessment of Test Results.....	42
4.6.8.1	Structural Adequacy.....	42
4.6.8.2	Occupant Risk.....	42
4.6.8.3	Vehicle Trajectory	44
CHAPTER 5. DESIGN AND TESTING OF DIRECT EMBEDDED STEEL SUPPORT		
TEMPORARY GUIDE SIGN SYSTEM		45
5.1	FOUNDATION POST DESIGN.....	45
5.2	STATIC TESTING ON DIRECT EMBEDDED STEEL FOUNDATION POSTS	47
5.3	TEST ARTICLE DESIGN AND CONSTRUCTION FOR CRASH TESTING	49
5.4	<i>MASH</i> TEST 3-60 ON THE DIRECT EMBEDDED STEEL SUPPORT TEMPORARY GUIDE SIGN SYSTEM (TEST NO. 467823-4).....	51
5.4.1	Test Designation and Actual Impact Conditions	51
5.4.2	Test Vehicle	51
5.3.3	Weather and Soil Conditions	51
5.3.4	Test Description.....	52

5.3.5	Damage to Test Installation	52
5.3.6	Vehicle Damage.....	53
5.3.7	Occupant Risk Factors	54
5.3.8	Assessment of Test Results.....	54
5.3.8.1	Structural Adequacy.....	54
5.3.8.2	Occupant Risk.....	56
5.3.8.3	Vehicle Trajectory	56
CHAPTER 6. SUMMARY AND CONCLUSIONS.....		57
6.1	DIRECT EMBEDDED WOOD SUPPORT TEMPORARY GUIDE SIGN SYSTEM.....	57
6.2	DIRECT EMBEDDED STEEL SUPPORT TEMPORARY GUIDE SIGN SYSTEM.....	58
CHAPTER 7. IMPLEMENTATION STATEMENT.....		65
7.1	DIRECT EMBEDDED WOOD SUPPORT TEMPORARY GUIDE SIGN SYSTEM.....	65
7.2	DIRECT EMBEDDED STEEL SUPPORT TEMPORARY GUIDE SIGN SYSTEM.....	65
REFERENCES		67
APPENDIX A. DETAILS OF THE DIRECT EMBEDDED WOOD SUPPORT TEMPORARY GUIDE SIGN SYSTEM.....		69
APPENDIX B. CRASH TEST NO. 467823-1		73
B.1	TEST VEHICLE PROPERTIES AND INFORMATION.....	73
B.2	SEQUENTIAL PHOTOGRAPHS	76
B.3	ANGULAR DISPLACEMENTS	78
B.4	VEHICLE ACCELERATIONS.....	79
APPENDIX C. CRASH TEST NO. 467823-2		85
C.1	TEST VEHICLE PROPERTIES AND INFORMATION.....	85
C.2	SEQUENTIAL PHOTOGRAPHS	88
B.3	ANGULAR DISPLACEMENTS	90
B.4	VEHICLE ACCELERATIONS.....	91
APPENDIX D. DETAILS OF THE MODIFIED DIRECT EMBEDDED WOOD SUPPORT TEMPORARY GUIDE SIGN SYSTEM		97
APPENDIX E. CRASH TEST NO. 467823-2b		103
E.1	TEST VEHICLE PROPERTIES AND INFORMATION.....	103
E.2	SEQUENTIAL PHOTOGRAPHS	106
E.3	ANGULAR DISPLACEMENTS	108
E.4	VEHICLE ACCELERATIONS.....	109
APPENDIX F. CRASH TEST NO. 467823-3		115
F.1	TEST VEHICLE PROPERTIES AND INFORMATION.....	115
F.2	SEQUENTIAL PHOTOGRAPHS	119
F.3	ANGULAR DISPLACEMENTS	121
F.4	VEHICLE ACCELERATIONS.....	122
APPENDIX G. DETAILS OF THE MODIFIED DIRECT EMBEDDED STEEL SUPPORT TEMPORARY GUIDE SIGN SYSTEM		129
APPENDIX H. CRASH TEST NO. 467823-4.....		133
H.1	TEST VEHICLE PROPERTIES AND INFORMATION.....	133
H.2	SEQUENTIAL PHOTOGRAPHS	136
H.3	ANGULAR DISPLACEMENTS	138
H.4	VEHICLE ACCELERATIONS.....	139

LIST OF FIGURES

		Page
Figure 2.1.	Wind Load Isotachs for Texas (1).	5
Figure 2.2.	Brom’s Cohesive Soil Foundation Model.....	9
Figure 2.3.	Recommended Design for Extruded Aluminum Sign Attached to Direct Embedded Wood Supports.	12
Figure 4.1.	Overall Details of the Direct Embedded Wood Support Temporary Guide Sign System.	20
Figure 4.2.	Direct Embedded Wood Support Temporary Guide Sign System before Test Nos. 467823-1 and 467823-2.....	20
Figure 4.3.	Vehicle before Test No. 467823-1.....	21
Figure 4.4.	Direct Embedded Wood Support Temporary Guide Sign System after Test No. 467823-1.	22
Figure 4.5.	Vehicle after Test No. 467823-1.....	23
Figure 4.6.	Summary of Results for <i>MASH</i> Test 3-60 on the Direct Embedded Wood Support Temporary Guide Sign System.	24
Figure 4.7.	Vehicle before Test No. 467823-2.....	26
Figure 4.8.	Direct Embedded Wood Support Temporary Guide Sign System after Test No. 467823-2.	28
Figure 4.9.	Vehicle after Test No. 467823-2.....	28
Figure 4.10.	Summary of Results for <i>MASH</i> Test 3-61 on the Direct Embedded Wood Support Temporary Guide Sign System.	30
Figure 4.11.	Design Options for Direct Embedded Wood Support Temporary Guide Sign System.....	32
Figure 4.12.	Modified Direct Embedded Wood Support Temporary Guide Sign System before Test No. 467823-2b.	33
Figure 4.13.	Modified Direct Embedded Wood Support Temporary Guide Sign System before Test Nos. 467823-2b and 467823-3.....	34
Figure 4.14.	Vehicle before Test No. 467823-2b.....	35
Figure 4.15.	Modified Direct Embedded Wood Support Temporary Guide Sign System after Test No. 467823-2b.	36
Figure 4.16.	Vehicle after Test No. 467823-2.....	36
Figure 4.17.	Summary of Results for <i>MASH</i> Test 3-61 on the Modified Direct Embedded Wood Support Temporary Guide Sign System.	38
Figure 4.18.	Vehicle before Test No. 467823-3.....	40
Figure 4.19.	Modified Direct Embedded Wood Support Temporary Guide Sign System after Test No. 467823-3.	41
Figure 4.20.	Vehicle after Test No. 467823-3.....	41
Figure 4.21.	Summary of Results for <i>MASH</i> Test 3-62 on the Modified Direct Embedded Wood Support Temporary Guide Sign System.	43
Figure 5.1.	Static Test Results for S3×5.7 (Test S1), W6×9 (Test S2), and W8×18 (Test S3).....	48
Figure 5.2.	Overall Details of the Direct Embedded Steel Support Temporary Guide Sign System.....	50
Figure 5.3.	Direct Embedded Steel Support Temporary Guide Sign System.	50

Figure 5.4.	Vehicle before Test No. 467823-4.....	52
Figure 5.5.	Direct Embedded Steel Support Temporary Guide Sign System after Test No. 467823-4.	53
Figure 5.6.	Vehicle after Test No. 467823-1.....	54
Figure 5.7.	Summary of Results for <i>MASH</i> Test 3-60 on the Direct Embedded Wood Support Temporary Guide Sign System.	55
Figure B1.	Sequential Photographs for Test No. 467823-1(Oblique and Perpendicular Views).	76
Figure B2.	Vehicle Angular Displacements for Test No. 467823-1.....	78
Figure B3.	Vehicle Longitudinal Accelerometer Trace for Test No. 467823-1 (Accelerometer Located at Center of Gravity).	79
Figure B4.	Vehicle Lateral Accelerometer Trace for Test No. 467823-1 (Accelerometer Located at Center of Gravity).	80
Figure B5.	Vehicle Vertical Accelerometer Trace for Test No. 467823-1 (Accelerometer Located at Center of Gravity).	81
Figure B6.	Vehicle Longitudinal Accelerometer Trace for Test No. 467823-1 (Accelerometer Located Rear of Center of Gravity).	82
Figure B7.	Vehicle Lateral Accelerometer Trace for Test No. 467823-1 (Accelerometer Located Rear of Center of Gravity).	83
Figure B8.	Vehicle Vertical Accelerometer Trace for Test No. 467823-1 (Accelerometer Located Rear of Center of Gravity).	84
Figure C1.	Sequential Photographs for Test No. 467823-2(Oblique and Perpendicular Views).	88
Figure C2.	Vehicle Angular Displacements for Test No. 467823-2.....	90
Figure C3.	Vehicle Longitudinal Accelerometer Trace for Test No. 467823-2 (Accelerometer Located at Center of Gravity).	91
Figure C4.	Vehicle Lateral Accelerometer Trace for Test No. 467823-2 (Accelerometer Located at Center of Gravity).	92
Figure C5.	Vehicle Vertical Accelerometer Trace for Test No. 467823-2 (Accelerometer Located at Center of Gravity).	93
Figure C6.	Vehicle Longitudinal Accelerometer Trace for Test No. 467823-2 (Accelerometer Located Rear of Center of Gravity).	94
Figure C7.	Vehicle Lateral Accelerometer Trace for Test No. 467823-2 (Accelerometer Located Rear of Center of Gravity).	95
Figure C8.	Vehicle Vertical Accelerometer Trace for Test No. 467823-2 (Accelerometer Located Rear of Center of Gravity).	96
Figure E1.	Sequential Photographs for Test No. 467823-2b(Oblique and Perpendicular Views).	106
Figure E2.	Vehicle Angular Displacements for Test No. 467823-2b.....	108
Figure E3.	Vehicle Longitudinal Accelerometer Trace for Test No. 467823-2b (Accelerometer Located at Center of Gravity).	109
Figure E4.	Vehicle Lateral Accelerometer Trace for Test No. 467823-2b (Accelerometer Located at Center of Gravity).	110
Figure E5.	Vehicle Vertical Accelerometer Trace for Test No. 467823-2b (Accelerometer Located at Center of Gravity).	111

Figure E6.	Vehicle Longitudinal Accelerometer Trace for Test No. 467823-2b (Accelerometer Located Rear of Center of Gravity).	112
Figure E7.	Vehicle Lateral Accelerometer Trace for Test No. 467823-2b (Accelerometer Located Rear of Center of Gravity).	113
Figure E8.	Vehicle Vertical Accelerometer Trace for Test No. 467823-2b (Accelerometer Located Rear of Center of Gravity).	114
Figure F1.	Sequential Photographs for Test No. 467823-3(Oblique and Perpendicular Views).	119
Figure F2.	Vehicle Angular Displacements for Test No. 467823-3.....	121
Figure F3.	Vehicle Longitudinal Accelerometer Trace for Test No. 467823-3 (Accelerometer Located at Center of Gravity).	122
Figure F4.	Vehicle Lateral Accelerometer Trace for Test No. 467823-3 (Accelerometer Located at Center of Gravity).	123
Figure F5.	Vehicle Vertical Accelerometer Trace for Test No. 467823-3 (Accelerometer Located at Center of Gravity).	124
Figure F6.	Vehicle Longitudinal Accelerometer Trace for Test No. 467823-3 (Accelerometer Located Rear of Center of Gravity).	125
Figure F7.	Vehicle Lateral Accelerometer Trace for Test No. 467823-3 (Accelerometer Located Rear of Center of Gravity).	126
Figure F8.	Vehicle Vertical Accelerometer Trace for Test No. 467823-3 (Accelerometer Located Rear of Center of Gravity).	127
Figure H1.	Sequential Photographs for Test No. 467823-4(Oblique and Perpendicular Views).	136
Figure H2.	Vehicle Angular Displacements for Test No. 467823-4.....	138
Figure H3.	Vehicle Longitudinal Accelerometer Trace for Test No. 467823-4 (Accelerometer Located at Center of Gravity).	139
Figure H4.	Vehicle Lateral Accelerometer Trace for Test No. 467823-4 (Accelerometer Located at Center of Gravity).	140
Figure H5.	Vehicle Vertical Accelerometer Trace for Test No. 467823-4 (Accelerometer Located at Center of Gravity).	141
Figure H6.	Vehicle Longitudinal Accelerometer Trace for Test No. 467823-4 (Accelerometer Located Rear of Center of Gravity).	142
Figure H7.	Vehicle Lateral Accelerometer Trace for Test No. 467823-4 (Accelerometer Located Rear of Center of Gravity).	143
Figure H8.	Vehicle Vertical Accelerometer Trace for Test No. 467823-4 (Accelerometer Located Rear of Center of Gravity).	144

LIST OF TABLES

	Page
Table 2.1. Wood Post Material Strengths.	6
Table 2.2. Sign Support Requirement Analysis.	7
Table 2.3. Flexural Capacity for Post Weakening Options for Below Sign.	8
Table 2.4. Minimum Calculated Foundation Embedment Depth.	9
Table 5.1. Recommended Embedment Depths for Selected Steel Supports.	46
Table 5.2. Calculated Capacities of Steel Posts and Corresponding Slip Bases (6).	48
Table 6.1. Performance Evaluation Summary for <i>MASH</i> Test 3-60 on the Direct Embedded Wood Support Temporary Guide Sign System.	59
Table 6.2. Performance Evaluation Summary for <i>MASH</i> Test 3-61 on the Direct Embedded Wood Support Temporary Guide Sign System.	60
Table 6.3. Performance Evaluation Summary for <i>MASH</i> Test 3-61 on the Modified Direct Embedded Wood Support Temporary Guide Sign System.	61
Table 6.4. Performance Evaluation Summary for <i>MASH</i> Test 3-62 on the Modified Direct Embedded Wood Support Temporary Guide Sign System.	62
Table 6.5. Performance Evaluation Summary for <i>MASH</i> Test 3-60 on the Direct Embedded Steel Support Temporary Guide Sign System.	63
Table B1. Vehicle Properties for Test No. 467823-1.	73
Table B2. Vehicle Exterior Crush Measurements for Test No. 467823-1.	74
Table B3. Occupant Compartment Measurements for Test No. 467823-1.	75
Table C1. Vehicle Properties for Test No. 467823-2.	85
Table C2. Vehicle Exterior Crush Measurements for Test No. 467823-2.	86
Table C3. Occupant Compartment Measurements for Test No. 467823-2.	87
Table E1. Vehicle Properties for Test No. 467823-2b.	103
Table E2. Vehicle Exterior Crush Measurements for Test No. 467823-2b.	104
Table E3. Occupant Compartment Measurements for Test No. 467823-2b.	105
Table F1. Vehicle Properties for Test No. 467823-3.	115
Table F2. Vehicle Parametric Measurement for Vertical CG for Test No. 467823-3.	116
Table F3. Vehicle Exterior Crush Measurements for Test No. 467823-3.	117
Table F4. Occupant Compartment Measurements for Test No. 467823-3.	118
Table H1. Vehicle Properties for Test No. 467823-4.	133
Table H2. Vehicle Exterior Crush Measurements for Test No. 467823-4.	134
Table H3. Occupant Compartment Measurements for Test No. 467823-4.	135

CHAPTER 1. INTRODUCTION

1.1 INTRODUCTION

A common issue during phased highway construction projects is the need to temporarily relocate large guide signs on the roadside or install new guide signs for temporary use. Many of these signs are larger than 100 square ft in size and cannot be accommodated on small sign supports.

The conventional concrete foundations used for large guide signs are costly and time consuming to install. They are equally costly to remove after construction is completed and, consequently, they are often left in place. This creates problems for mowing and other maintenance operations.

There is a need for temporary support systems that are more cost effective to install and remove than conventional steel reinforced drilled concrete foundations for the temporary placement or relocation of large guide signs during construction projects. These systems must be crashworthy and capable of accommodating wind load requirements.

1.2 OBJECTIVES/SCOPE OF RESEARCH

The objective of this research project was to develop support systems for temporary installations of guide signs. Various types of guide signs are commonly used along highway roadsides including destination signs, advance exit signs, logo signs, etc. In Texas, a standard work zone sign is the “Give Us a Brake” sign, which is part of a work zone safety campaign. This sign is 16-ft wide × 8-ft tall with an area of 128 square ft. Texas Department of Transportation personnel noted that this sign is relocated often during construction projects and would serve as a good sign configuration that should be considered under the research project.

The analysis and evaluation of the temporary support systems developed under this project included consideration of wind load, foundation requirements, and impact performance. Wind load and foundation requirements were assessed in terms of the American Association of State Highway and Transportation Officials (AASHTO) *Standard Specifications for Structural Supports for Highway Signs, Luminaires, and Traffic Signals (1)*. Impact performance of the sign support systems was evaluated based on the AASHTO *Manual for Assessing Safety Hardware (MASH)* requirements (2). *MASH* requires up to three full-scale crash tests to evaluate the crashworthiness of a breakaway sign support structure.

Direct embedded support systems were developed for both wood and steel support systems. The wood post support system was designed for use with signs having areas up to 128 square ft. The evaluation of the direct embedded wood post system included consideration of factors such as support member size, length, grade, availability, spacing, and cost.

The direct embedded steel post foundation system was designed to be used in temporary applications with any size sign on a crashworthy steel sign support system. In Texas, permanent

large guide signs are installed on steel post systems with rectangular, 4-bolt slip bases. If an existing sign on the roadside needs to be relocated, use of the existing sign substrate and steel sign support members on a temporary direct embedment steel foundation post will reduce the relocation cost. When designing with a steel post system, consideration was given to both the size and embedment depth of the foundation post.

CHAPTER 2. DIRECT EMBEDMENT WOOD SUPPORT SYSTEM

2.1 SUPPORT SELECTION

Wood supports are often used for both permanent and temporary sign applications. Previous research has shown that weakening wood posts through the use of drilled holes at strategic locations has enhanced crashworthiness without sacrificing a significant percentage of their wind load capacity. A national pooled-fund study entitled “*Testing of Small and Large Sign Supports*” performed in the early 1990s crash tested and evaluated numerous wood sign support configurations (3). The testing was conducted at the Federal Highway Administration’s Federal Outdoor Impact Laboratory (FOIL) using a 1800-lb passenger car following *National Cooperative Highway Research Program Report 350* guidelines (4).

FHWA letter HNG-14/SS-36 summarizes the testing conducted under the pooled-fund study (5). Most posts were Southern Yellow Pine (SYP) species. The size, number of supports installed, and number of posts impacted varied. Support posts were tested in single and multiple configurations. Some tests involved impacting one or two posts in dual or multiple support installations. This is an important distinction because the behavior of the sign support system differs depending on whether or not all posts in an installation are impacted. If all posts (e.g., two posts in a dual post installation) are impacted, the wood posts fracture at the ground and the released sign support system rotates above the vehicle. If only one post is impacted in a dual or multiple post installation, the sign support system remains attached to the ground through the other support posts and the interaction with the vehicle can be substantially different.

Supports successfully tested and considered eligible for use on the National Highway System (NHS) include:

- (1) A single, unmodified 4-inch × 6-inch SYP post,
- (2) Dual 4-inch × 6-inch SYP posts with 1½-inch diameter holes drilled through the post along its strong axis at heights of 4 inches and 18 inches above grade,
- (3) A single 5-inch diameter round SYP post with 2-inch diameter weakening holes at 4 inches and 18 inches above grade, and
- (4) One post of a dual post system using 6-inch × 8-inch SYP posts with 3-inch diameter weakening holes at 4 inches and 18 inches above grade.

Additional wood post configurations found to be acceptable through other testing and analyses include:

- (1) A single, unmodified 5-inch × 5-inch SYP post (FHWA letter HNG-14/SS-50),
- (2) A single 6-inch × 6-inch SYP post with 2-inch diameter weakening holes at 4 inches and 18 inches above grade (FHWA letter HSSD/SS-160), and
- (3) Dual, unmodified 4-inch × 6-inch Western Red Cedar posts (FHWA letter HNG-14/SS-46A).

When impacting only a single support of a dual or multi-support configuration is acceptable, the supports must be placed 7 ft or more apart such that they cannot be struck simultaneously by an errant vehicle.

Data from these full-scale crash tests were reviewed to determine which wood post configurations have a reasonable probability of complying with the impact performance criteria of American Association of State Highway and Transportation Officials *Manual for Assessing Safety Hardware* (5). Occupant impact velocity (OIV) was considered to be the most critical criterion for assessment of crashworthiness. The small car slow speed impact (Test Designation 3-60) is typically most critical in terms of OIV. In tests of single supports, OIV values were extrapolated to decide if multiple supports could be impacted with a reasonable probability of satisfactory results.

Based on this review, it was estimated that three 4-inch × 6-inch posts with 2-inch weakening holes near groundline and two 6-inch × 8-inch posts with 4-inch weakening holes near groundline had a high probability of meeting the impact performance requirements of *MASH*. TTI researchers recommended additional weakening of the support posts below the sign panel for both post configurations to facilitate fracture and release of one or more posts from the sign panel in situations where not all posts were simultaneously impacted.

2.2 WIND LOAD ANALYSIS

In addition to being crashworthy, sign supports must also meet wind load requirements described in the AASHTO *Standard Specifications for Structural Supports for Highway Signs, Luminaires, and Traffic Signals* (1). The basic wind speed is associated with an annual event probability of 0.02 (or a 50-year mean recurrence interval) and is prescribed by isotachs contained in the AASHTO *Specification*. The basic wind speed is modified by an importance factor based on the recommended minimum design life of a structure. The recommended minimum design life for roadside sign structures is 10 years.

The wind pressure on a sign can be calculated using the following equation (6):

$$P_z = 0.00256 K_z G (V * C_v)^2 I_r C_d \text{ (psf)}$$

where:

- P_z = Design Wind Pressure (psf)
- I_r = Wind Importance Factor
- C_v = Velocity Conversion Factor
- K_z = Height and Exposure Factor
- G = Gust Effect Factor
- C_d = Wind Drag Coefficients
- V = Basic Wind Speed (mph), from Wind Chart

Figure 1 shows that the basic wind speed varies with geographical location across Texas and ranges from 90 mph to 130 mph along portions of the southern coast. Since 90 and 100 mph

wind speeds cover most of the state (except for some extreme coastal regions subject to hurricanes), and the large guide sign support system is defined to be temporary in nature, 90 and 100 mph wind speeds were evaluated. A 90 mph design wind speed with a 10 year recurrence interval equates to a wind pressure of 11.5 psf, while a 100 mph design wind speed equates to a wind pressure of 14.2 psf. The researchers utilized these values to determine the required number of support posts and the maximum hole size that can be utilized to weaken the support to help facilitate fracture during vehicle impacts.

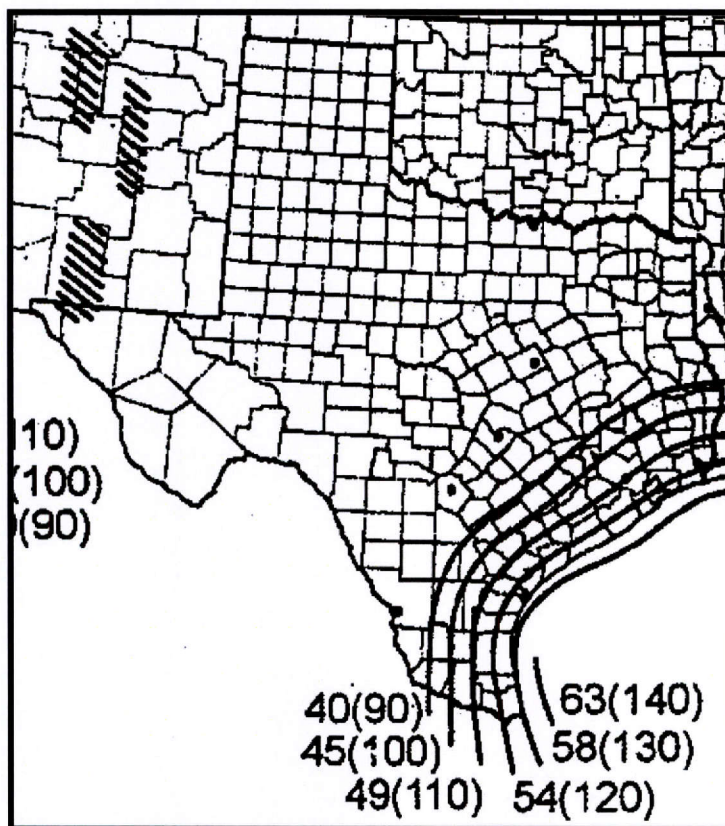

Figure 2.1. Wind Load Isotachs for Texas (1).

There are many factors involved in determining the minimum number of support posts required. The primary factors include sign size, sign mounting height, post size, and post grade. Table 2.1 shows how material strength of a post is affected by post size and grade. The researchers evaluated 6-inch × 8-inch and 4-inch × 6-inch posts for application to the large temporary guide signs. These post sizes provide significant flexure capacity to accommodate wind loads for relatively large signs and were believed to have a reasonable probability of meeting impact performance requirements for multiple post impacts. Both Grade 1 and Grade 2 posts were analyzed.

In Texas, the minimum mounting height for signs is 7 ft measured relative to the pavement surface. Because signs are typically installed on roadside slopes beyond the shoulder, actual mounting height from the local terrain to the bottom of the sign panel is typically larger

depending on the roadside terrain and offset distance of the sign from the edge of travelway. Therefore, the researchers considered a range of mounting heights from 7 to 10 ft.

Table 2.1. Wood Post Material Strengths.

	[4x4]		[4x5] and [4x6]		[5x5] or greater		Units
	No. 2	No. 1	No. 2	No. 1	No. 2	No. 1	
Fb	1500	1850	1250	1650	850	1350	psi
Ft	825	1050	725	900	550	900	psi
Fv	90	100	90	90	100	110	psi
Fc	1650	1850	1600	1750	525	825	psi
E	1.60E+06	1.70E+06	1.60E+06	1.70E+09	1.20E+06	1.50E+06	psi

Fb = bending; Ft = tension parallel to grain; Fv = shear parallel to grain;
Fc = compression parallel to grain; E = modulus of elasticity

An analysis was performed to determine reasonable support configurations for a 16 ft × 8-ft tall (128 ft²) sign. Table 2.2 shows the results of the analysis. A 100 mph design wind speed, 10 ft mounting height above the local terrain, and Grade 2 post represents the worst case for windload considerations. This configuration requires eight 4-inch × 6-inch posts with a weakening hole no larger than 2.15-inch diameter, or five 6-inch × 8-inch posts with a maximum weakening hole size of 4.33-inch diameter.

MASH requires crash testing with both a 2420-lb passenger car (denoted 1100C) and a 5000-lb pickup truck (denoted 2270P). Testing houses typically use a Kia Rio for the 1100C design vehicle and a Dodge Ram 1500 pickup truck for the 2270P. The Kia Rio has a maximum width (excluding mirrors) of 67 inches, while the Dodge Ram pickup has a maximum width (excluding mirrors) of 82 inches. Using these data, the researchers determined that in all of the design cases except one, a maximum of two 6-inch × 8-inch posts would be impacted. The data also show that on average a 4-inch hole can be utilized to weaken the 6-inch × 8-inch support without compromising wind load requirements. The weakening holes will be drilled along the strong axis of the post at heights of 4 inches and 18 inches above the ground surface, which is consistent with previous successfully tested designs.

Table 2.2 also shows that in most configurations with 4-inch × 6-inch support posts, three posts will be impacted by the Kia Rio and up to four can possibly be impacted by the Dodge Ram pickup. The analysis shows that on average, a 2-inch hole can be utilized to weaken the 4-inch × 6-inch support.

2.3 POST ACTIVATION BELOW SIGN PANEL

The researchers considered it necessary to weaken the posts below the sign panel to facilitate fracture and release of a post in a multiple support system during impacts that do not engage all posts. Steel post systems use fuse plates to create hinge or release points below the sign panel that permit an impacted post to rotate out of the path of the vehicle. Wood support posts can be weakened using saw cuts or holes drilled through the cross section of the post.

Table 2.2. Sign Support Requirement Analysis.

	Wind Velocity	Sign Mounting Height	Post Size	Max Hole Size	Number of Posts	Minimum Post Spacing	Number of Posts Impacted
	(mph)	(ft)	(in)	(in)		(ft)	
Grade 1	100	10	4x6	1.98	6	2.67	3
			6x8	3.91	3	5.33	2
		7	4x6	2.7	5	3.20	2,3
			6x8	5.39	3	5.33	2
	90	10	4x6	2.39	5	3.20	2,3
			6x8	5.26	3	5.33	2
		7	4x6	2.58	4	4.00	2
			6x8	4.31	2	8.00	1
Grade 2	100	10	4x6	2.15	8	2.00	3,4
			6x8	4.33	5	3.20	2,3
		7	4x6	0.42	6	2.67	3
			6x8	4.46	4	4.00	2
	90	10	4x6	2.93	7	2.29	3
			6x8	4.23	4	4.00	2
		7	4x6	1.83	5	3.20	2,3
			6x8	3.8	3	5.33	2

Several options are available for weakening the post at the location just below the bottom of the sign. These include various size holes or saw cuts applied along the strong or weak axes of the post. A minimum section modulus (S_x) of 16.15 inches³ is required to accommodate wind load just below the sign panel. Table 2.3 shows the calculated section modulus for various weakening options. While section strength can be precisely defined using saw cuts, the depth of saw cuts is more difficult to reliably control and inspect. The researchers selected a weakening option of a 3⁵/₈-inch diameter hole drilled along the weak axis of the post approximately 4 inches below the bottom of the sign panel. The section modulus of the post at this weakened section is 25.5 inches³. This option provides a reasonable balance between meeting wind load requirements and selecting a hole size that is not too large to be reliably and cleanly drilled through the 6-inch width of the post.

2.4 FOUNDATION DESIGN

The AASHTO *Standard Specifications for Structural Supports for Highway Signs, Luminaires, and Traffic Signals* (6) suggests use of Brom's method for design of foundations for sign support structures. This method has two complimentary models for analyzing foundation requirements. One model is for the design of foundations in cohesionless soils such as sand, and the other is intended to be used for cohesive soils such as clay. The natural in-situ soil at TTI's Proving Ground is a black, cohesive clay.

Table 2.3. Flexural Capacity for Post Weakening Options for Below Sign.

Description			Sx (in ³)
Wind Force Requirements			16.15
Option 1	A	4" Hole Diameter	56
Single Hole Strong Axis			
Option 2	A	2" Hole Diameter	45.45
Dual Hole Strong Axis	B	3" Hole Diameter	26.12
Option 3	A	2" Depth	16
Saw Cut	B	1.75" Depth	20.25
Option 4	A	4" Hole Diameter	21.33
Single Hole Weak Axis	B	3" Hole Diameter	32

Figure 2.2 is a representation of the foundation analysis model for cohesive soils. In this analysis, the suggested safety factor (SF) can range from 3 to 4. The more conservative value of 4 was used in the foundations analyses performed under this research. Shear (V) and Moment (M) were taken from the wind load analysis. The equations below determine the minimum embedment depth (L) for the foundation. A “c” value of 3100 psf was used when calculating the minimum embedment depth for the in-situ clay found at the Texas A&M Transportation Institute Proving Ground at which the system was tested.

$$V_f = V_{req} * SF$$

$$M_f = M_{req} * SF$$

$$L = 1.5 * D + q \left[1 + \sqrt{2 + \frac{4 * H + 6 * D}{q}} \right]$$

$$H = \frac{M_f}{V_f}$$

$$q = \frac{V_f}{9 * c * D}$$

The results of this analysis can be found in Table 2.4. The required embedment depth for a 4-inch × 6-inch post varies from 4.0 - 4.9 ft. The embedment depth for a 6-inch × 8-inch post varies between 3.6 and 4.3 ft. Given the factor of safety in the analysis, it was recommended that the foundation embedment depth be standardized at 4 ft. This depth will reduce the complexity of the design and installation of the temporary sign support system. If the supports are to be placed in non-cohesive soils, it is recommended that the foundation embedment depth be reanalyzed using Brom’s method for cohesionless soils. If soils are known to be stronger than the values used herein, the analysis can be repeated using actual soil values to take advantage of the stronger soil conditions to reduce the required embedment depth.

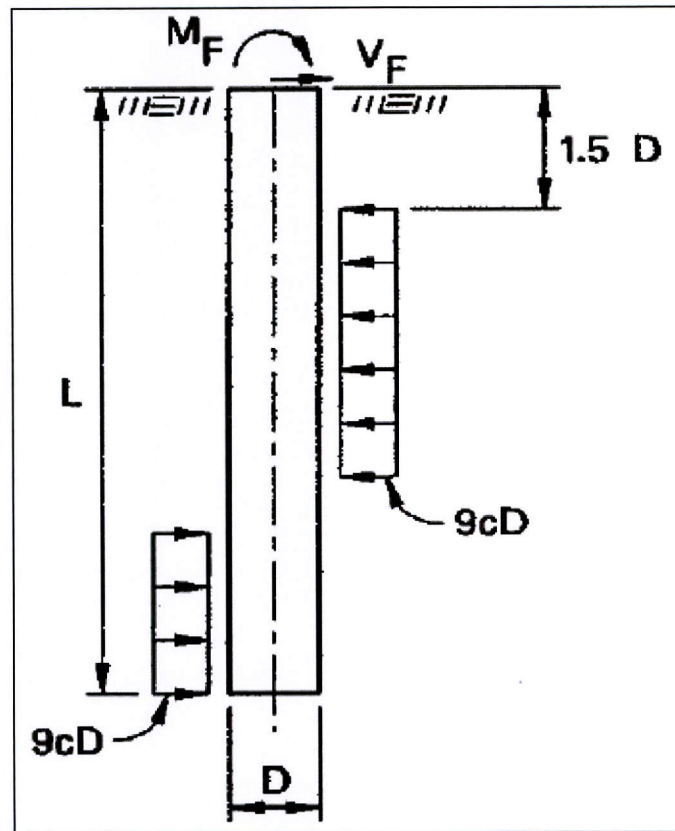

Figure 2.2. Brom's Cohesive Soil Foundation Model.

Table 2.4. Minimum Calculated Foundation Embedment Depth.

V (mph)	Z _{bs} (ft)	Post Size	Embedment Depth
100	10	4x6	4.82
		6x8	4.26
	7	4x6	4.38
		6x8	3.9
90	10	4x6	4.36
		6x8	3.89
	7	4x6	3.96
		6x8	3.57

2.5 SIGN SUBSTRATE CONNECTIONS

TxDOT uses extruded aluminum signs almost exclusively on its permanent roadside guide signs. Plywood is a commonly used substrate for temporary sign support systems. After discussion with TxDOT personnel, it was decided that both extruded aluminum and plywood substrates would be considered in the design of the temporary large guide sign support systems. This will give contractors more flexibility to choose a sign substrate that is most economical based on factors such as material cost, fabrication cost, weight (handling), durability, etc. If an existing guide sign is being relocated, it would be cost-effective to use the existing extruded aluminum sign panel. If a new sign is being deployed in the work zone, a plywood sign substrate may be more economical.

Connection details exist for attaching an extruded aluminum sign panel to a steel support post. The standard connection used in Texas for permanent guide signs involves inserting the square head of a bolt into a channel fabricated into the back side of the extruded aluminum panel. A cast clamp is inserted onto the bolt and secured with a nut. The clamp is positioned to extend over the flange of the steel support post. When the connection bolt is tightened, the extruded aluminum sign panel is clamped to the steel sign post.

A connection between an extruded aluminum sign panel and wood support post was developed using standard clamp connection hardware as shown in Figure 2.3. A 3-inch \times 2-inch \times 1/4-inch steel angle is attached to each side of the wood support member. The length of the angle matches the vertical dimension of the extruded aluminum sign panel. One leg of each angle is placed flush with the sides of the wood support and attached using 1/2-inch diameter, 3-inch long lag screws spaced at approximately 2-ft intervals. The other leg of the angles is placed flush with the front face of the wood support post and extends perpendicularly outward from the post. The clamp connection hardware is used to clamp the extruded aluminum sign panel to the steel angle in a similar manner to the front flange of a steel post.

The researchers also developed connection details for connecting a plywood sign panel to the wood support posts (see page 3 of Figure 2.3). The recommended thickness for the plywood substrate sign panel is 5/8-inch. Aluminum wind beams run horizontally along the width of the plywood sign panel approximately 5 inches from the top and bottom edges of the sign panel. Interior wind beams are placed at maximum 4-ft spacing. The wind beams are secured to the plywood substrate using 5/16-inch diameter \times 1 1/4-inch long hex bolts. Aluminum plates measuring 3-inch wide \times 1/8-inch thick are placed along joints in the plywood sign substrate and secured using #10 \times 5/8-inch long pan head screws. The 3-inch \times 2-inch \times 1/4-inch steel angles are attached to the sides of each wood support member as described above. Square head bolts slide into a channel fabricated into the back side of the aluminum wind beams. The top bolt slides into a 1/2 inch wide \times 3/4-inch long slot cut into the edge of the angle and is secured with a nut. The remaining bolts are clamped to the edges of the angle in the same manner described above for the extruded aluminum sign substrate. The top bolt has a more positive connection because there are fewer clamps to attach the plywood substrate to the supports than the extruded aluminum substrate.

Due to the reduced number of clamps on the plywood substrate connection, the researchers feel that this design is less critical from an impact standpoint compared to the

extruded aluminum sign panels. It is believed that the plywood substrate has an increased chance of releasing from the wood sign supports during a vehicular impact errant. Therefore, it was decided to conduct the compliance testing of the temporary large guide sign support system with an extruded aluminum sign panel.

2.6 CRASHWORTHINESS

In addition to being able to accommodate service loads, sign support systems placed within the clear zone on a highway roadside must also be crashworthy. The design impact requirements for roadside hardware are performance based and consist of a prescribed crash test matrix with impact conditions defined in terms of vehicle type, vehicle mass, impact speed, and impact angle.

Current guidance on the impact performance evaluation of sign support structures is contained in the AASHTO *Manual for Assessing Safety Hardware (MASH) (2)*. According to *MASH*, a matrix of three tests is recommended to evaluate the impact performance of a new sign support system. This includes two small car tests (low speed and high speed) and one pickup truck test. The tests were performed at the Texas A&M Transportation Institute Proving Ground. The TTI Proving Ground is an International Standards Organization (ISO) 17025 accredited laboratory.

The recommended size and number of support posts in a system will vary based on size of the sign panel, sign panel mounting height, and design wind speed. The size of the sign panel is based upon the information being conveyed to motorists. The mounting height (at ground level) depends on the roadside slope and the offset from the edge of travelway. The design wind speed varies with geographic location within the state.

Obviously, not all possible design configurations can be crash tested. The approach used under this research was to select a critical configuration from among those considered practical. A successful test of the critical configuration can be used to establish acceptance of other less critical design configurations. Acceptance letters issued by the FHWA have established precedence for this approach. For example, testing with a stronger Grade 1 wood will provide the basis of acceptance for weaker Grade 2 material. Similarly, successfully impacting two support posts simultaneously will allow for acceptance of configurations with larger post spacing in which only one 6-inch × 8-inch post can be impacted.

Additionally, engineering calculations can be used as the basis for acceptance for other support post types. The full-scale crash testing will establish an upper limit on post strength. Therefore, various combinations of 4-inch × 6-inch posts with appropriately sized weakening holes would be acceptable provided their combined flexural strength (as defined by section modulus) is less than or equal to the combined strength of the weakened 6-inch × 8-inch posts. Thus, a set of guidelines and standards for direct embedment wood supports can be developed based on testing of the recommended sign support configuration. The following chapters describe the full-scale crash testing of the temporary guide sign with direct embedded wood supports.

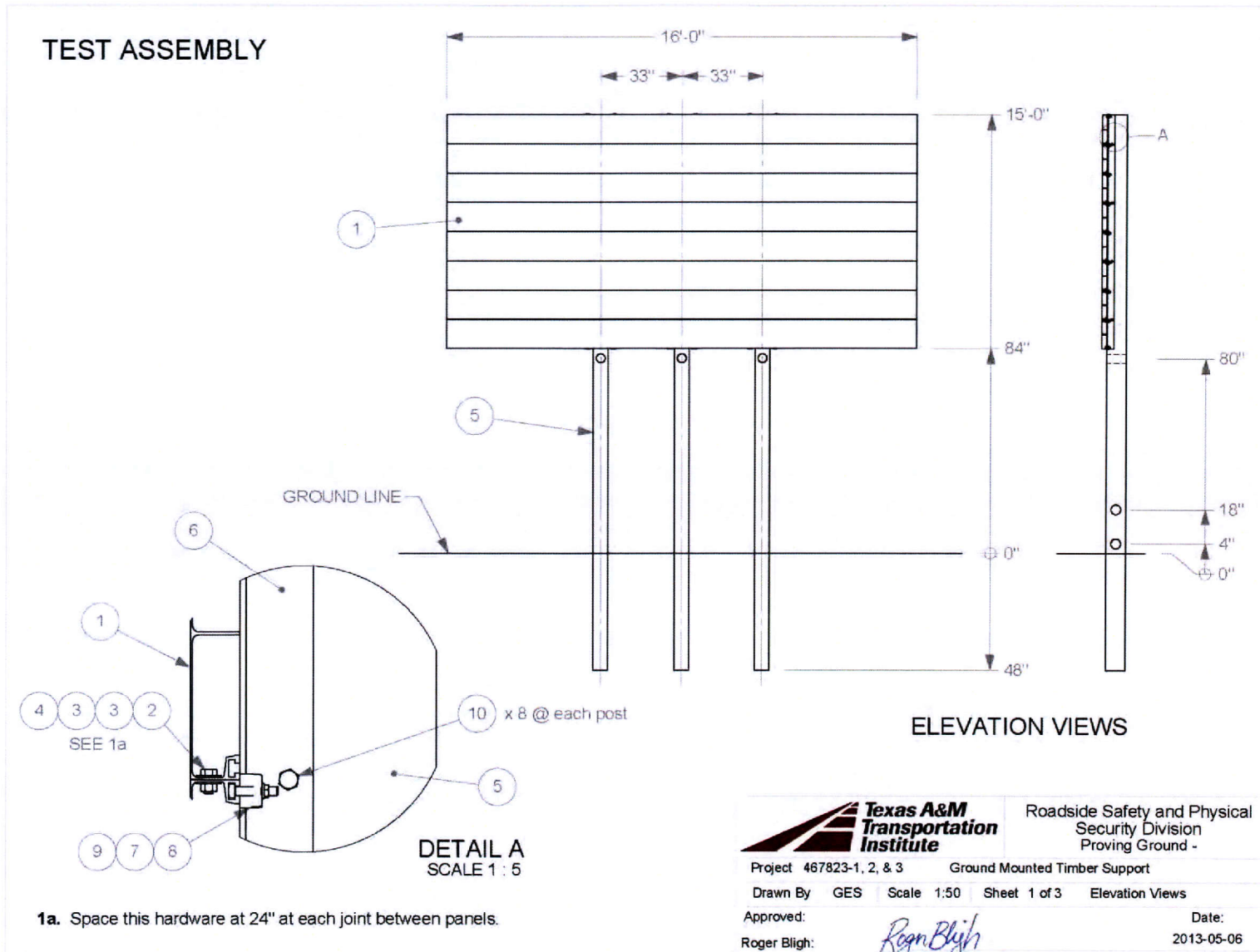

T:\2012-2013\467823-TxDOT Temp Sign Support\Ground Mounted Timber Support\Drafting\2013-05-06\467823-1 Drawing

Figure 2.3. Recommended Design for Extruded Aluminum Sign Attached to Direct Embedded Wood Supports.

INSTALLATION PARTS			
#	PART NAME	DETAILS	QTY.
1	Aluminum Sign Panel, 12' x 16'	see TxDOT Drawing SMD (2-1) -08	8
2	Bolt, 3/8 x 3/4 hex	grade 2	56
3	Washer, 3/8 flat		112
4	Nut, 3/8 hex		56
5	Timber Post	sheet 3	3
6	Angle Stiffener	sheet 3	6
7	Bolt, 3/8 x 1-3/4 square head	see TxDOT Drawing SMD (2-1) -08	54
8	Sign Clip	see TxDOT Drawing SMD (2-1) -08	54
9	Nut, 3/8 flange		54
10	1/2 x 3 Lag Bolt	A307	24

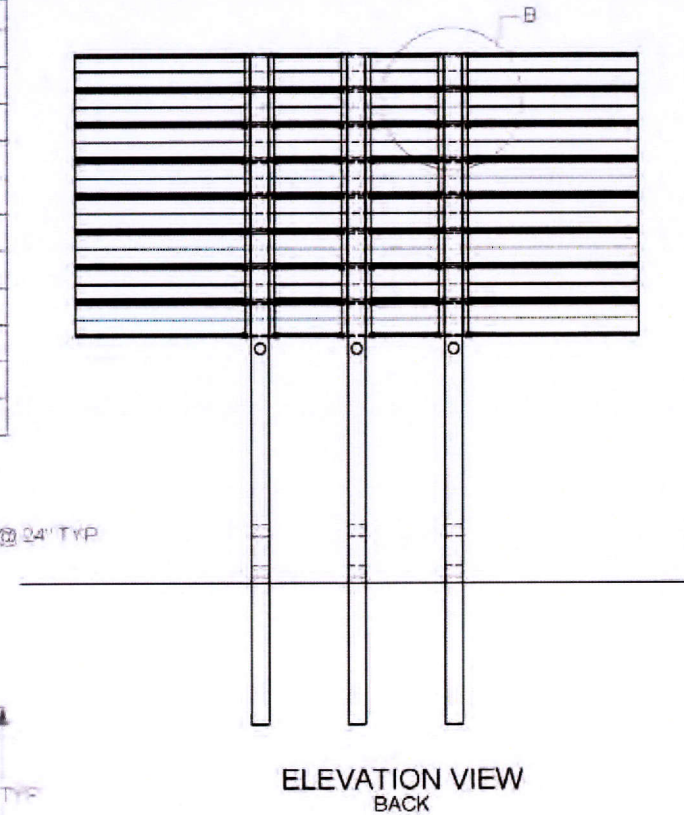
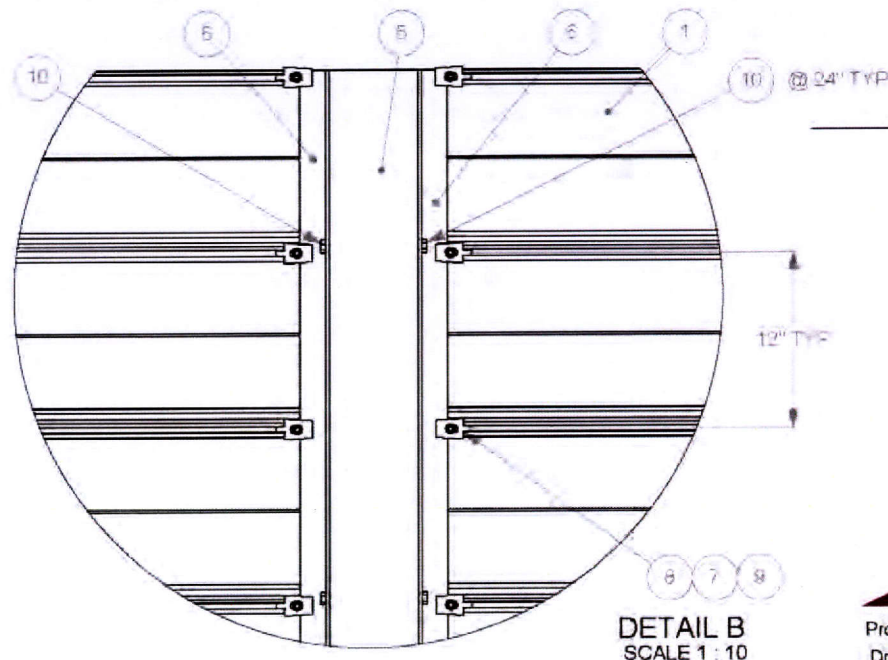

Roadside Safety and
Physical Security Division -
Proving Ground

Project 467823-1, 2, & 3 Ground Mounted Timber Support 2013-05-06
Drawn By GES Scale 1:50 Sheet 2 of 3 Back View

T:\2012-2013\467823-TxDOT Temp Sign Support\Ground Mounted Timber Support\Drafting\2013-05-06\467823-1 Drawing

Figure 2.3. Recommended Design for Extruded Aluminum Sign Attached to Direct Embedded Wood Supports (continued).

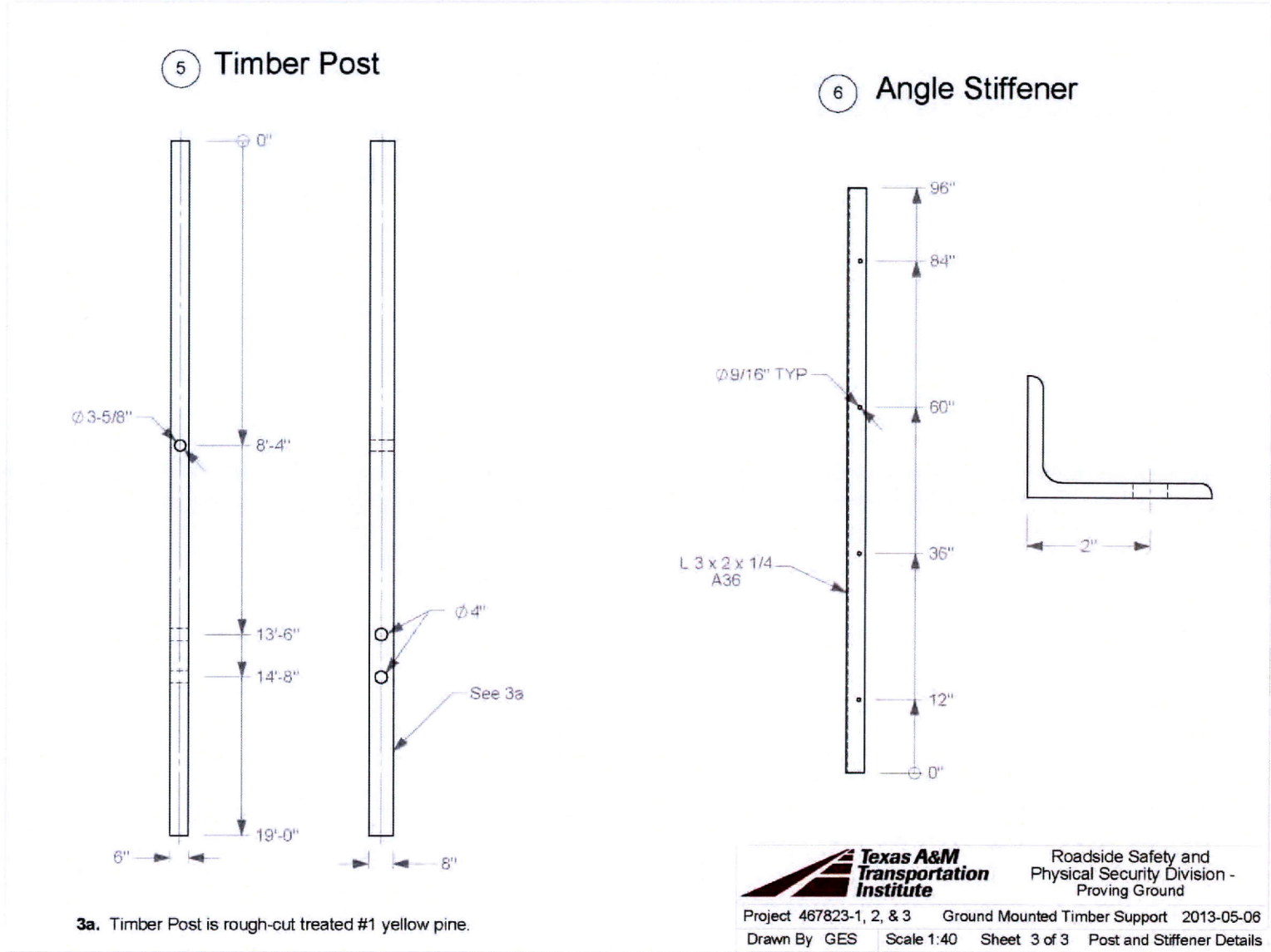

T:\2012-2013\467823-TxDOT Temp Sign Support\Ground Mounted Timber Support\Drafting\2013-05-06\467823-1 Drawing

Figure 2.3. Recommended Design for Temporary Large Guide Sign with Direct Embedded Wood Supports (continued).

CHAPTER 3. *MASH* CRASH TEST REQUIREMENTS AND PROCEDURES

3.1 TEST FACILITY

The full-scale crash test reported here was performed at Texas Transportation Institute Proving Ground, an International Standards Organization 17025 accredited laboratory with American Association for Laboratory Accreditation (A2LA) Mechanical Testing certificate 2821.01. The full-scale crash test was performed according to TTI Proving Ground quality procedures and according to the *MASH* guidelines and standards.

The Texas A&M Transportation Institute Proving Ground is a 2000-acre complex of research and training facilities located 10 miles northwest of the main campus of Texas A&M University. The site, formerly an Air Force base, has large expanses of concrete runways and parking aprons well-suited for experimental research and testing in the areas of vehicle performance and handling, vehicle-roadway interaction, durability and efficacy of highway pavements, and safety evaluation of roadside safety hardware. The site selected for construction and testing of the sign supports evaluated under this project was along the an out-of-service apron. The apron consists of an unreinforced jointed-concrete pavement in 12.5-ft × 15-ft blocks nominally 6 inches deep. The apron is over 60 years old, and the joints have some displacement but are otherwise flat and level.

3.2 CRASH TEST MATRIX

The full-scale crash testing performed under this project was in accordance with the guidelines and procedures set forth in *MASH*. The recommended matrix for evaluating breakaway support structures to test level 3 (TL-3) consists of three tests:

- ***MASH* Test 3-60:** An 1100C (2425 lb/1100 kg) vehicle impacting the device at a nominal impact speed of 30 mi/h and critical impact angle (CIA) judged to have the greatest potential for test failure. This test evaluates the kinetic energy required to activate the breakaway, fracture, or yielding mechanism of the supports.
- ***MASH* Test 3-61:** An 1100C (2425 lb/1100 kg) vehicle impacting the device at a nominal impact speed of 62 mi/h and CIA judged to have the greatest potential for test failure. This test evaluates the behavior of the device during high-speed impact with a small vehicle.
- ***MASH* Test 3-62:** A 2270P (5000 lb/2270 kg) vehicle impacting the device at a nominal impact speed of 62 mi/h and CIA judged to have the greatest potential for test failure. This test evaluates the behavior of the device during high-speed impact with a pickup truck.

The crash tests on the direct embedded wood support systems were performed using an impact angle of zero degrees. This permitted both support posts to be simultaneously impacted, thus providing the most critical case for evaluating occupant risk and secondary contact of the fractured supports with the vehicle.

The crash test and data analysis procedures were in accordance with guidelines presented in *MASH*. A summary of these procedures is provided below.

3.3 EVALUATION CRITERIA

The crash tests were evaluated in accordance with applicable criteria presented in *MASH*. The performance of sign supports is judged primarily on the basis of structural adequacy and occupant risk. Structural adequacy is judged upon the ability of the sign support to readily activate in a predictable manner by breaking away, fracturing, or yielding. Occupant risk is evaluated based on factors such as occupant compartment deformation, intrusion of structural components into the vehicle windshield, vehicle stability, and occupant impact velocity. The appropriate safety evaluation criteria from Table 5-1 of *MASH* were used to evaluate the crash test reported herein. These criteria are listed in further detail under the assessment of the crash test.

3.4 VEHICLE TOW AND GUIDANCE PROCEDURES

Each test vehicle was towed into the test installation using a steel cable guidance and reverse tow system. A steel cable for guiding the test vehicle was tensioned along the path, anchored at each end, and threaded through an attachment to the front wheel of the test vehicle. An additional steel cable was connected to the test vehicle, passed around a pulley near the impact point, through a pulley on the tow vehicle, and then anchored to the ground such that the tow vehicle moved away from the test site. A two-to-one speed ratio between the test and tow vehicle existed with this system. Just prior to impact with the installation, the system released the test vehicle to be unrestrained. The vehicle remained free-wheeling (i.e., no steering or braking inputs) until it cleared the immediate area of the test site, after which the brakes were activated, if needed, to bring it to a safe and controlled stop.

3.5 DATA ACQUISITION SYSTEMS

3.5.1 Vehicle Instrumentation and Data Processing

Each test vehicle was instrumented with a self-contained, on-board data acquisition system. The signal conditioning and acquisition system is a 16-channel, Tiny Data Acquisition System (TDAS) Pro produced by Diversified Technical Systems, Inc. The accelerometers, that measure the x, y, and z axis of vehicle acceleration, are strain gauge type with linear millivolt output proportional to acceleration. Angular rate sensors, measuring vehicle roll, pitch, and yaw rates, are ultra small size, solid state units designs for crash test service. The TDAS Pro hardware and software conform to the latest SAE J211, Instrumentation for Impact Test. Each of the 16 channels is capable of providing precision amplification, scaling, and filtering based on transducer specifications and calibrations. During the test, data are recorded from each channel at a rate of 10,000 values per second with a resolution of one part in 65,536. Once recorded, the data are backed up inside the unit by internal batteries should the primary battery cable be severed. Initial contact of the pressure switch on the vehicle bumper provides a time zero mark as well as initiating the recording process. After each test, the data are downloaded from the TDAS Pro unit into a laptop computer at the test site. The raw data are then processed by the Test Risk Assessment Program (TRAP) software to produce detailed reports of the test results. Each of the TDAS Pro units are returned to the factory annually for complete recalibration.

Accelerometers and rate transducers are also calibrated annually with traceability to the National Institute for Standards and Technology. Acceleration data are measured with an expanded uncertainty of ± 1.7 percent at a confidence factor of 95 percent ($k=2$).

TRAP uses the data from the TDAS Pro to compute occupant/compartiment impact velocities, time of occupant/compartiment impact after vehicle impact, and the highest 10-millisecond (ms) average ridedown acceleration. TRAP calculates change in vehicle velocity at the end of a given impulse period. In addition, maximum average accelerations over 50-ms intervals in each of the three directions are computed. For reporting purposes, the data from the vehicle-mounted accelerometers are filtered with a 60-Hz digital filter, and acceleration versus time curves for the longitudinal, lateral, and vertical directions are plotted using TRAP.

TRAP uses the data from the yaw, pitch, and roll rate transducers to compute angular displacement in degrees at 0.0001-s intervals and then plots yaw, pitch, and roll versus time. These displacements are in reference to the vehicle-fixed coordinate system with the initial position and orientation of the vehicle-fixed coordinate systems being initial impact. Rate of rotation data is measured with an expanded uncertainty of ± 0.7 percent at a confidence factor of 95 percent ($k=2$).

3.5.2 Anthropomorphic Dummy Instrumentation

An Alderson Research Laboratories Hybrid II, 50th percentile male anthropomorphic dummy, restrained with lap and shoulder belts, was placed in the driver's position of each 1100C vehicle. The dummy was uninstrumented. Use of a dummy in the 2270P vehicle is optional according to *MASH*, and no dummy was used in the test with the 2270P vehicle.

3.5.3 Photographic Instrumentation and Data Processing

Photographic coverage of each test included two high-speed cameras: one placed behind the installation at an angle and a second placed to have a field of view perpendicular to the path of the vehicle and aligned with the installation. A flashbulb activated by pressure-sensitive tape switches was positioned on the impacting vehicle to indicate the instant of contact with the installation and was visible from each camera. The videos from these high-speed cameras were analyzed on a computer-linked motion analyzer to observe phenomena occurring during the collision and to obtain time-event, displacement, and angular data. A mini-DV camera and still cameras recorded and documented conditions of the test vehicle and installation before and after the test.

CHAPTER 4. CRASH TEST RESULTS FOR DIRECT EMBEDDED WOOD SUPPORT TEMPORARY GUIDE SIGN SYSTEM

4.1 TEST ARTICLE DESIGN AND CONSTRUCTION

The required size and number of support posts for a temporary guide sign will vary based on size of the sign panel, sign panel mounting height, and design wind speed. Obviously, not all possible design configurations can be crash tested. The approach used under this research was to select a critical configuration from among those considered practical. A successful test of the critical configuration will provide acceptance for other less critical configurations.

The test installation involved an 8-ft tall \times 16-ft wide (128 square ft) extruded aluminum sign panel supported by three 6-inch \times 8-inch, Grade 1, Southern Yellow Pine wood support posts at a mounting height of 7 ft from the ground to the bottom of the sign panel.

The spacing of the wood support posts was 33 inches center to center. This is closer than the spacing would be in a typical field installation of this sign but was done to permit two of the three supports to be simultaneously impacted by the test vehicle. The wood support posts were directly embedded 48 inches below grade. The supports were weakened with 4-inch diameter holes drilled along the strong axis of the post (i.e., parallel to the orientation of the sign panel) at heights of 4 inches and 18 inches above the ground line. These holes facilitate fracture of the supports during a vehicle impact while still accommodating the required wind load capacity for a 90 mph design wind speed. Additionally, the supports were weakened below the sign panel with a $3\frac{3}{8}$ -inch diameter hole drilled along the weak axis of the post (i.e., perpendicular to the orientation of the sign panel). These holes permit the wood post to fracture and release from the sign panel in a manner analogous to the fuse plates that are used with standard steel supports.

A $3\times 2\times \frac{1}{4}$ -inch steel angle was secured to each side of each wood support member using $\frac{1}{2}$ -inch diameter \times 3-inch long lag bolts at 24-inch spacing. The length of the angles matched the height of the extruded aluminum sign panel. Standard clamp connection hardware similar to that shown on TxDOT standard drawing SMD (2-1)-08 was used to clamp the extruded aluminum sign panel to the steel angle in a similar manner to the front flange of a steel post. Figure 4.1 gives overall details of the system, and Figure 4.2 shows photographs of the test installation prior to testing. Appendix A provides further construction details for the system.

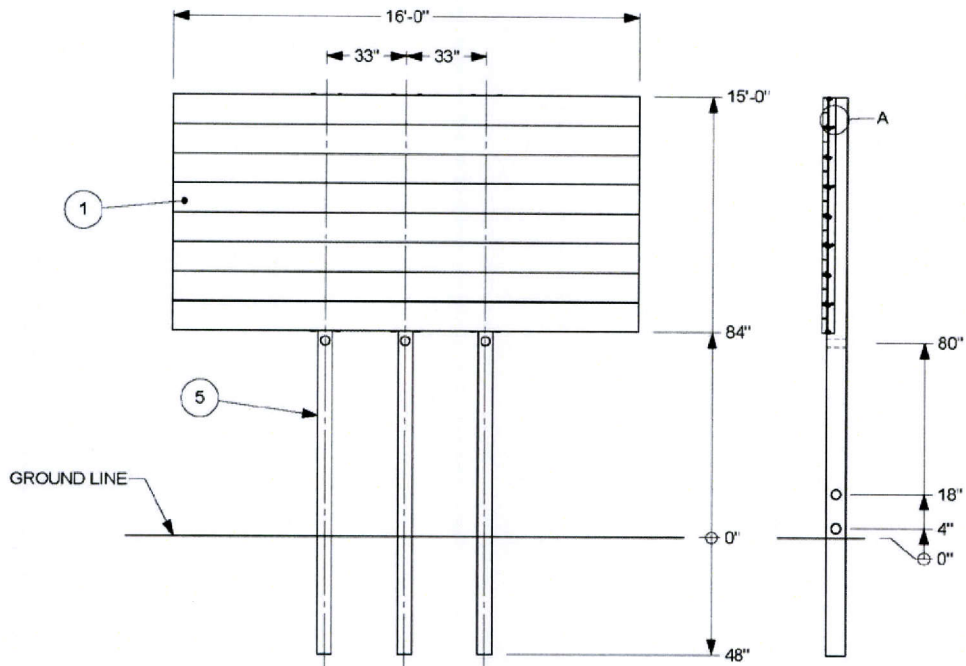

Figure 4.1. Overall Details of the Direct Embedded Wood Support Temporary Guide Sign System.

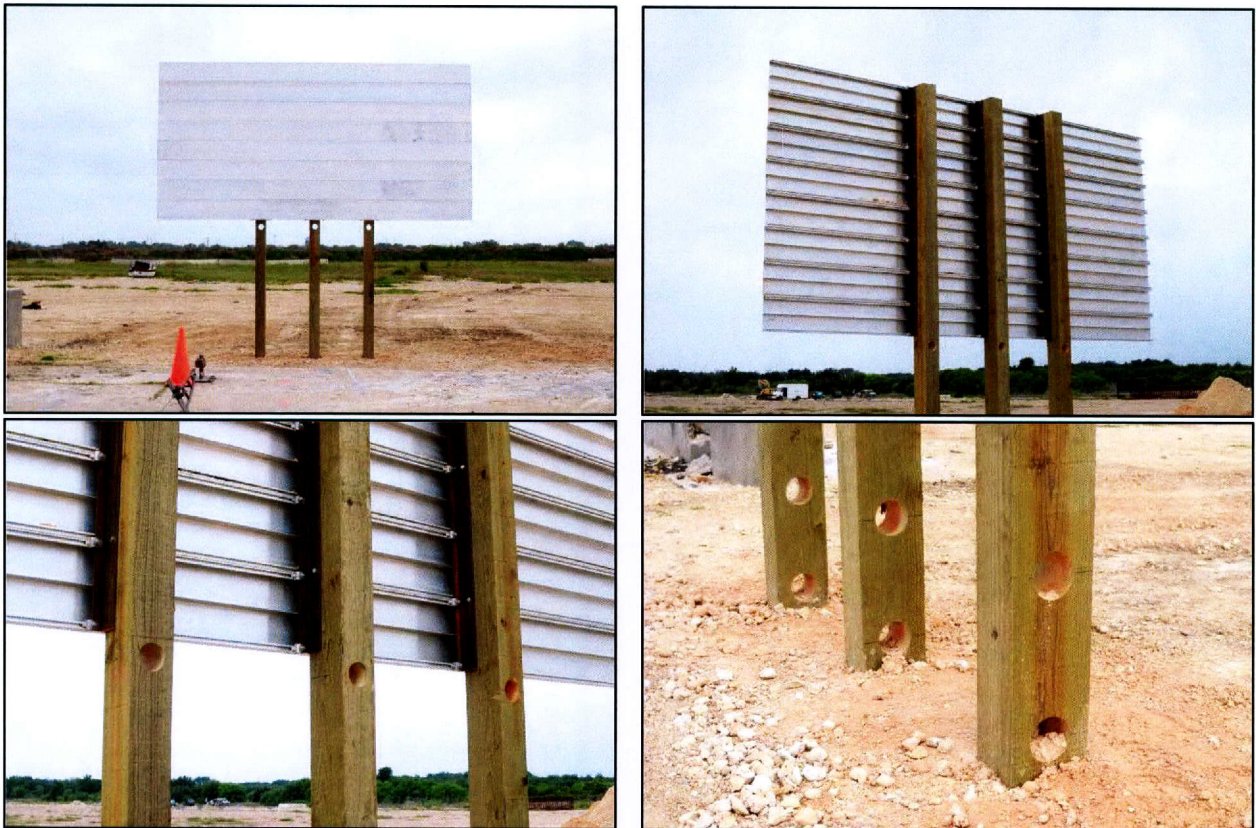

Figure 4.2. Direct Embedded Wood Support Temporary Guide Sign System before Test Nos. 467823-1 and 467823-2.

4.2 MASH TEST 3-60 ON THE DIRECT EMBEDDED WOOD SUPPORT TEMPORARY GUIDE SIGN SYSTEM (TEST NO. 467823-1)

4.2.1 Test Designation and Actual Impact Conditions

MASH Test 3-60 involves a 1100C vehicle weighing 2420 lb \pm 55 lb impacting the sign support at an impact speed of 19 mi/h \pm 2.5 mi/h and a critical impact angle of 0 degrees \pm 1.5 degrees. The target impact point was centerline of the vehicle aligned with centerline between the two supports. The 2008 Kia Rio used for the test had a test inertial weight of 2443 lb, and the actual impact speed and angle were 18.8 mi/h and 0 degrees, respectively. The actual impact point was centerline of the vehicle aligned with centerline between the two supports on the left side of the sign system.

4.2.2 Test Vehicle

A 2008 Kia Rio, shown in Figure 4.3, was used for the crash test. Test inertia weight of the vehicle was 2443 lb, and its gross static weight was 2612 lb. The height to the lower edge of the vehicle bumper was 7.12 inches, and it was 21.0 inches to the upper edge of the bumper. Table B1 in Appendix B gives additional dimensions and information on the vehicle. The vehicle was directed into the installation using the cable reverse tow and guidance system and was released to be free-wheeling and unrestrained just prior to impact.



Figure 4.3. Vehicle before Test No. 467823-1.

4.2.3 Weather and Soil Conditions

The test was performed on the morning of May 24, 2013. Weather conditions at the time of testing were as follows: wind speed: 6 mi/h; wind direction: 150 degrees with respect to the vehicle (vehicle was traveling in a northerly direction); temperature: 80°F, relative humidity: 84 percent.

The test installation was installed in standard soil meeting AASHTO standard specifications for “Materials for Aggregate and Sol Aggregate Subbase, Base and Surface Courses,” designated M147-65(2004), grading B. In accordance with Appendix B of *MASH*, soil strength was measured the day of the crash test. The minimum post load required for deflections at 5 inches, 10 inches, and 15 inches, measured at a height of 25 inches, is 3940 lb, 5500 lb, and 6540 lb, respectively (90% of static load for the initial standard installation). On the day of the

test, May 24, 2013, load on the post at deflections of 5 inches, 10 inches, and 15 inches was 8000 lbf, 10,545 lbf, and 12,000 lbf, respectively. The strength of the backfill material met minimum requirements.

4.2.4 Test Description

The 2008 Kia Rio, traveling at an impact speed of 18.8 mi/h, impacted the middle and left legs of the sign support at an impact angle of 0 degrees. At approximately 0.014 s, the middle support leg began to deflect away from the vehicle, and at 0.136 s, the middle and left support legs had fractured at the holes near ground level and the sign panel began to rotate. The rotation caused the sign panel to pry off and release from the remaining right support post at 0.402 s. The sign panel, middle support leg, and upper portion of the fractured middle support leg subsequently fell and contacted the roof of the vehicle at 0.686 s. As the vehicle exited the view of the high-speed cameras, the sign panel and supports were sliding off the driver's side of the vehicle. Brakes on the vehicle were applied at 3.2 s after impact, and the vehicle came to rest 45 ft behind the impact location. Figures B1 and B2 in Appendix B show sequential photographs of the test period.

4.2.5 Damage to Test Installation

Figure 4.4 shows damage to the wood post sign support system after the test. The left support leg fractured at the hole near ground level and remained connected to the sign panel. The middle support leg fractured at the hole the hole near ground level and below the sign panel. The upper portion of the middle support leg remained attached to the sign panel. The right support leg remained intact and the soil around the post was only disturbed. The sign panel separated from the right support leg and contacted the roof of the vehicle before coming to rest on the ground.

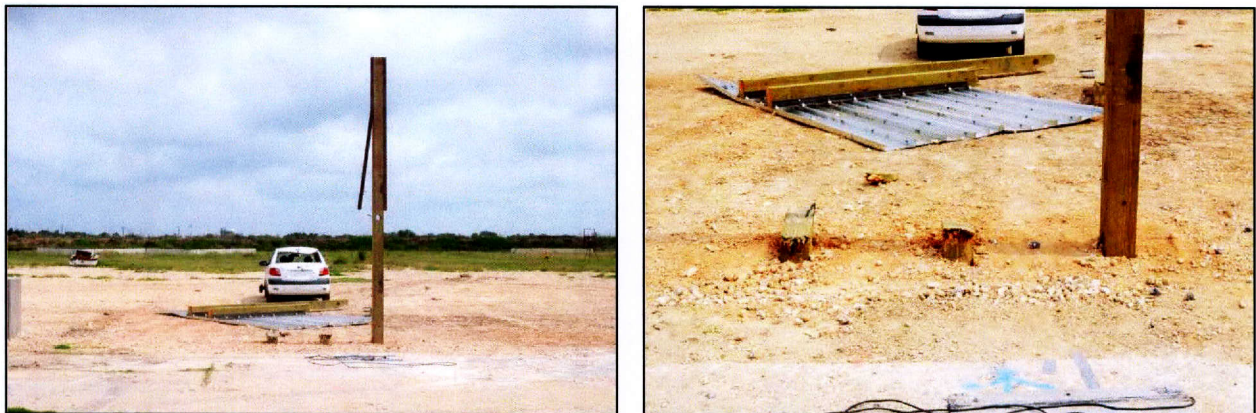

Figure 4.4. Direct Embedded Wood Support Temporary Guide Sign System after Test No. 467823-1.

4.2.6 Vehicle Damage

Figure 4.5 shows the damage sustained by the vehicle during the test, which included the front bumper, hood, windshield, right A-post, roof, left C-post, top of trunk lid, and left rear quarter panel. The hood was deformed 2.0 inches in the front plane just left of centerline of the

vehicle. The windshield shattered over an area of 12 inches \times 16 inches near the top center, and just above this area the roof was pushed downward towards the occupant compartment 1.75 inches. Just right of centerline of the roof over the rear passenger compartment was an area measuring 23 inches \times 24 inches that was deformed downward towards the occupant compartment. Maximum occupant compartment deformation was 3.5 inches in the roof over the right rear occupant compartment. Exterior crush and occupant compartment measurements can be found in Tables B2 and B3 of Appendix B.



Figure 4.5. Vehicle after Test No. 467823-1.

4.2.7 Occupant Risk Factors

Data from the accelerometer located at the vehicle center of gravity were digitized for evaluation of occupant risk. In the longitudinal direction, the occupant impact velocity was 11.2 ft/s at 0.240 s, the highest 0.010-s occupant ridedown acceleration was 0.9 Gs from 0.254 to 0.264 s, and the maximum 0.050-s average acceleration was -4.7 Gs between 0.001 and 0.051 s. In the lateral direction, the occupant impact velocity was 2.0 ft/s at 0.240 s, the highest 0.010-s occupant ridedown acceleration was 1.0 Gs from 2.838 to 2.848 s, and the maximum 0.050-s average was 0.7 Gs between 0.222 and 0.272 s. Theoretical Head Impact Velocity (THIV) was 12.6 km/h or 3.5 m/s at 0.241 s; Post-Impact Head Decelerations (PHD) was 1.3 Gs between 0.254 and 0.264 s; and Acceleration Severity Index (ASI) was 0.40 between 0.000 and 0.050 s. Figure 4.6 summarizes these data and other pertinent information from the test. Vehicle angular displacements and accelerations versus time traces are presented in Appendix B, Figures B3 through B9.

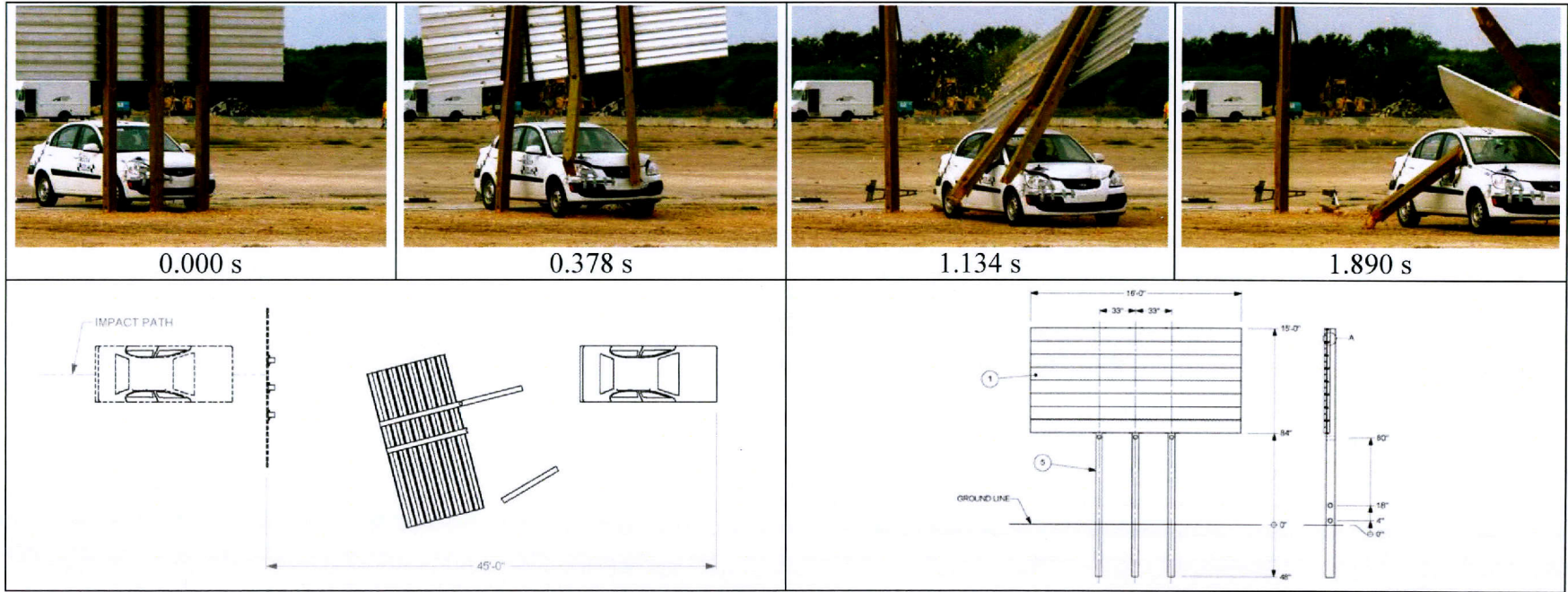

General Information

Test Agency Texas A&M Transportation Institute (TTI)
 Test Standard Test No. MASH Test 3-60
 TTI Test No. 467823-1
 Test Date 2013-06-24

Test Article

Type Sign Support
 Name TxDOT Direct Embedded Wood Support
 Temporary Guide Sign System
 Installation Mounting Height 7 ft
 Material or Key Elements 8-ft x 16-ft extruded aluminum sign panel
 on three 6-inch x 8-inch weakened wood
 support posts

Soil Type

..... Standard Soil of Crushed Limestone

Test Vehicle

Type/Designation 1100C
 Make and Model 2008 Kia Rio
 Curb 2789 lb
 Test Inertial 2443 lb
 Dummy 169 lb
 Gross Static 2612 lb

Impact Conditions

Speed 18.8 mi/h
 Angle 0 degrees
 Location/Orientation Left 2 supports

Exit Conditions

Speed Not attainable
 Angle 0 degrees

Occupant Risk Values

Impact Velocity
 Longitudinal 11.2 ft/s
 Lateral 2.0 ft/s
 Ridedown Accelerations
 Longitudinal 0.9 G
 Lateral 1.0 G
 THIV 3.5 m/s
 PHD 1.3 G
 ASI 0.40

Max. 0.050-s Average

Longitudinal -4.7 G
 Lateral 0.7 G
 Vertical -1.8 G

Post-Impact Trajectory

Stopping Distance 45 ft dwnstrm

Vehicle Stability

Maximum Yaw Angle 37 degrees
 Maximum Pitch Angle 2 degrees
 Maximum Roll Angle 9 degrees
 Vehicle Snagging NA
 Vehicle Pocketing NA

Test Article Debris Pattern

Longitudinal 35 ft
 Lateral 16 ft

Vehicle Damage

VDS 12FD1
 CDC 12FDEW1
 Max. Exterior Deformation 3.5 inches
 OCDI FS0100000
 Max. Occupant Compartment
 Deformation 3.5 inches

Figure 4.6. Summary of Results for MASH Test 3-60 on the Direct Embedded Wood Support Temporary Guide Sign System.

4.2.8 Assessment of Test Results

An assessment of the test based on applicable *MASH* safety evaluation criteria is provided below.

4.2.8.1 Structural Adequacy

B. *The test article should readily activate in a predictable manner by breaking away, fracturing, or yielding.*

Results: The direct embedded wood post support system for temporary guide signs performed acceptably by fracturing at the upper and lower weakening holes. (PASS)

4.2.8.2 Occupant Risk

D. *Detached elements, fragments, or other debris from the test article should not penetrate or show potential for penetrating the occupant compartment, or present an undue hazard to other traffic, pedestrians, or personnel in a work zone.*

Deformation of, or intrusions into, the occupant compartment should not exceed limits set forth in Section 5.3 and Appendix E of MASH. (roof ≤ 4.0 inches; windshield = ≤ 3.0 inches; side windows = no shattering by test article structural member; wheel/foot well/toe pan ≤ 9.0 inches; forward of A-pillar ≤ 12.0 inches; front side door area above seat ≤ 9.0 inches; front side door below seat ≤ 12.0 inches; floor pan/transmission tunnel area ≤ 12.0 inches).

Results: The detached sections of the supports did not penetrate or show potential for penetrating the occupant compartment, nor to present an undue hazard to others. (PASS)

Maximum occupant compartment deformation was 3.5 inches in the right rear passenger roof area. (PASS)

F. *The vehicle should remain upright during and after collision. The maximum roll and pitch angles are not to exceed 75 degrees.*

Results: The 1100C vehicle remained upright during and after the collision event. Maximum roll and pitch angles were 9 degrees and 2 degrees, respectively. (PASS)

H. *Occupant impact velocities should satisfy the following:*

Longitudinal and Lateral Occupant Impact Velocity

<u>Preferred</u>	<u>Maximum</u>
10 ft/s	16.4 ft/s

Results: Longitudinal occupant impact velocity was 11.2 ft/s, and lateral occupant impact velocity was 2.0 ft/s. (PASS)

- I. *Occupant ridedown accelerations should satisfy the following:*
- | | |
|---|----------------|
| <i>Longitudinal and Lateral Occupant Ridedown Accelerations</i> | |
| <u>Preferred</u> | <u>Maximum</u> |
| 15.0 Gs | 20.49 Gs |

Results: Maximum longitudinal ridedown acceleration was 0.9 G, and maximum lateral ridedown acceleration was 1.0 G. (PASS)

4.2.8.3 *Vehicle Trajectory*

- N. *Vehicle trajectory behind the test article is acceptable.*

Result: The 1100C vehicle came to rest 45 ft behind the installation. (PASS)

4.3 **MASH TEST 3-61 ON THE DIRECT EMBEDDED WOOD SUPPORT TEMPORARY GUIDE SIGN SYSTEM (TEST NO. 467823-2)**

4.3.1 **Test Designation and Actual Impact Conditions**

MASH Test 3-61 involves an 1100C vehicle weighing 2420 lb ±55 lb impacting the sign support at a speed of 62 mi/h ±2.5 mi/h and a critical impact angle of 0 degrees ±1.5 degrees. The target impact point was centerline of the vehicle aligned with the centerline between two supports. The 2006 Kia Rio used in the test had a test inertial weight of 2432 lb, and the actual impact speed and angle were 61.6 mi/h and 0 degrees, respectively. The actual impact point was centerline of the vehicle aligned with the centerline between the two supports on the right side of the sign support system.

4.3.2 **Test Vehicle**

A 2006 Kia Rio, shown in Figure 4.7, was used for the crash test. Test inertia weight of the vehicle was 2432 lb, and its gross static weight was 2611 lb. The height to the lower edge of the vehicle bumper was 7.12 inches, and the height to the upper edge of the bumper was 21.0 inches. Table C1 in Appendix C gives additional dimensions and information on the vehicle. The vehicle was directed into the installation using the cable reverse tow and guidance system and was released to be free-wheeling and unrestrained just prior to impact.

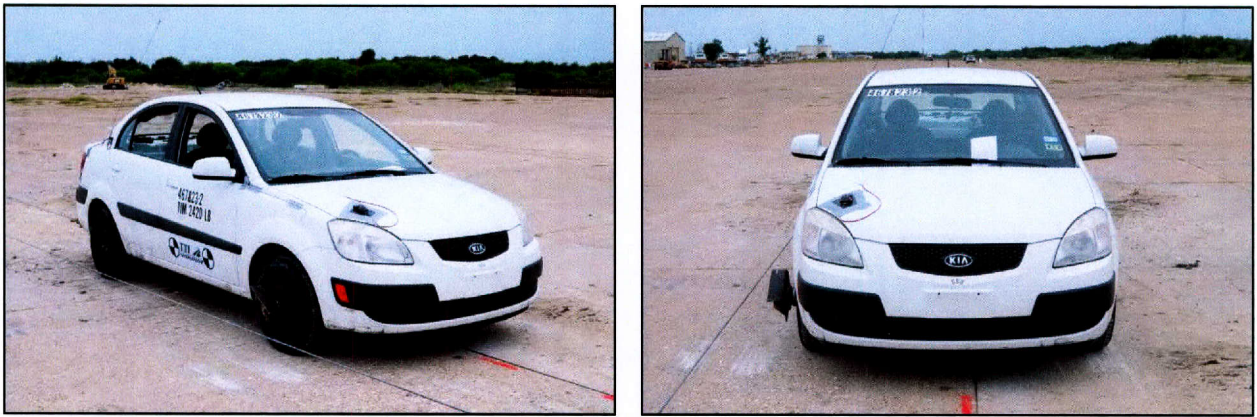

Figure 4.7. Vehicle before Test No. 467823-2.

4.3.3 Weather and Soil Conditions

The test was performed on the afternoon of May 24, 2013. Weather conditions at the time of testing were as follows: wind speed: 4 mi/h; wind direction: 150 degrees with respect to the vehicle (vehicle was traveling in a northerly direction); temperature: 86°F, relative humidity: 70 percent.

The test installation was installed in standard soil meeting AASHTO standard specifications for “Materials for Aggregate and Sol Aggregate Subbase, Base and Surface Courses”, designated M147-65(2004), grading B. In accordance with Appendix B of *MASH*, soil strength was measured the day of the crash test. The minimum post load required at deflections at 5 inches, 10 inches, and 15 inches, measured at a height of 25 inches, is 3940 lb, 5500 lb, and 6540 lb, respectively (90% of static load for the initial standard installation). On the day of the test, May 24, 2013, load on the post at deflections of 5 inches, 10 inches, and 15 inches was 8757 lbf, 10,012 lbf, and 9606 lbf, respectively. The strength of the backfill material met minimum requirements.

4.3.4 Test Description

The 2006 Kia Rio, traveling at an impact speed of 61.6 mi/h, impacted the middle and right support legs of the sign support at an impact angle of 0 degrees. At approximately 0.008 s, the right support leg began to deflect away from the vehicle, and at 0.012 s, the middle and right support legs began to fracture at the holes at bumper height. The middle and right support legs fractured at the holes just below the sign panel at 0.034 s. The fractured support legs rotated toward the vehicle and penetrated the windshield at 0.092 s. Brakes on the vehicle were applied at 0.38 s after impact, and the vehicle came to rest 196 ft behind the impact location. Figures C1 and C2 in Appendix C show sequential photographs of the test period.

4.3.5 Damage to Test Installation

Figure 5.8 shows damage to the wood post sign support after the test. The right and middle support legs fractured at the holes near ground level and at the holes just below the sign panel. One of the fractured supports came to rest 136 ft downstream of impact and the other was resting in front of the vehicle at final rest. The sign remained standing and attached to the left wood support leg, and the soil around this support was only disturbed.

4.3.6 Vehicle Damage

Figure 4.9 shows the damage sustained by the vehicle during the test, which included the front bumper, hood, and windshield. The front bumper was deformed inward 1.0 inch right of centerline of the vehicle. Both supports penetrated through the windshield and into the occupant compartment. The windshield had two holes: one on the driver side measuring 7 inches × 14 inches and one on the passenger side measuring 7 inches × 8 inches. Exterior crush and occupant compartment measurements can be found in Tables C2 and C3 of Appendix C.

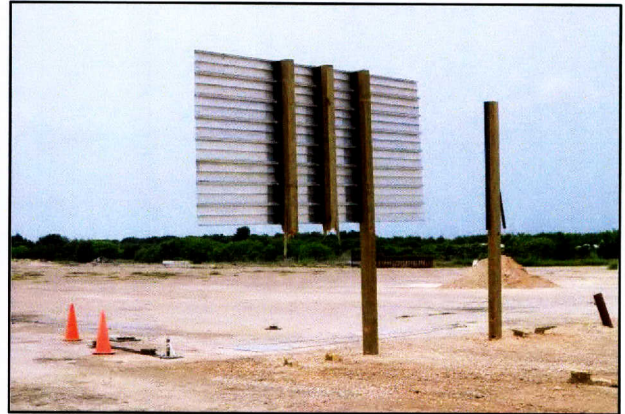
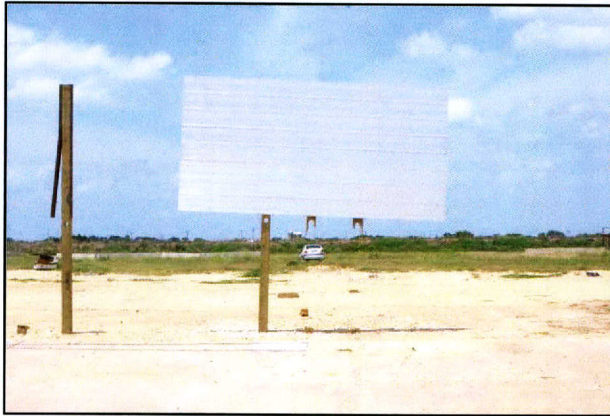

Figure 4.8. Direct Embedded Wood Support Temporary Guide Sign System after Test No. 467823-2.



Figure 4.9. Vehicle after Test No. 467823-2.

4.3.7 Occupant Risk Factors

Data from the accelerometer located at the vehicle center of gravity were digitized for evaluation of occupant risk. In the longitudinal direction, the occupant impact velocity was 8.5 ft/s at 0.273 s, the highest 0.010-s occupant ridedown acceleration was 2.0 Gs from 0.684 to 0.694 s, and the maximum 0.050-s average acceleration was -3.8 Gs between 0.000 and 0.050 s. In the lateral direction, the occupant impact velocity was 0.3 ft/s at 0.273 s, the highest 0.010-s

occupant ridedown acceleration was 1.0 Gs from 1.432 to 1.442 s, and the maximum 0.050-s average was 0.6 Gs between 0.160 and 0.210 s. Theoretical Head Impact Velocity was 9.5 km/h or 2.6 m/s at 0.273 s; Post-Impact Head Decelerations was 2.0 Gs between 0.684 and 0.694 s; and Acceleration Severity Index was 0.34 between 0.000 and 0.050 s. Figure 4.10 summarizes these data and other pertinent information from the test. Vehicle angular displacements and accelerations versus time traces are presented in Appendix C, Figures C3 through C9.

4.3.8 Assessment of Test Results

An assessment of the test based on the applicable *MASH* safety evaluation criteria is provided below.

4.3.8.1 Structural Adequacy

B. *The test article should readily activate in a predictable manner by breaking away, fracturing, or yielding.*

Results: The direct embedded wood post support system for temporary guide signs fractured at the upper and lower weakening holes as designed. (PASS)

4.3.8.2 Occupant Risk

D. *Detached elements, fragments, or other debris from the test article should not penetrate or show potential for penetrating the occupant compartment, or present an undue hazard to other traffic, pedestrians, or personnel in a work zone.*

Deformation of, or intrusions into, the occupant compartment should not exceed limits set forth in Section 5.3 and Appendix E of MASH. (roof ≤ 4.0 inches; windshield = ≤ 3.0 inches; side windows = no shattering by test article structural member; wheel/foot well/toe pan ≤ 9.0 inches; forward of A-pillar ≤ 12.0 inches; front side door area above seat ≤ 9.0 inches; front side door below seat ≤ 12.0 inches; floor pan/transmission tunnel area ≤ 12.0 inches).

Results: The fractured sections of posts rotated into and penetrated the windshield of the vehicle. (FAIL)

F. *The vehicle should remain upright during and after collision. The maximum roll and pitch angles are not to exceed 75 degrees.*

Results: The 1100C vehicle remained upright during and after the collision event. Maximum roll and pitch angles were 6 degrees and 3 degrees, respectively. (PASS)

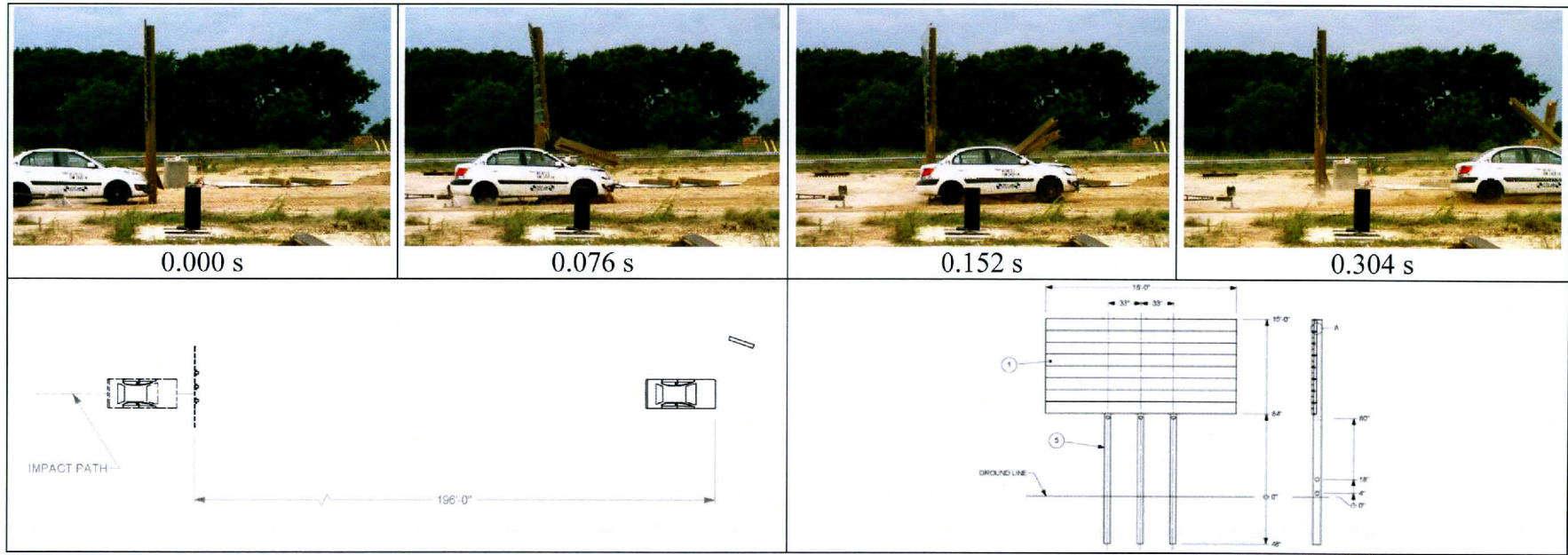

General Information

Test Agency Texas A&M Transportation Institute (TTI)
 Test Standard Test No. MASH Test 3-61
 TTI Test No. 467823-2
 Test Date 2013-06-24

Test Article

Type Sign Support
 Name TxDOT Direct Embedded Wood Support
 Temporary Guide Sign System
 Installation Mounting Height 7 ft
 Material or Key Elements 8-ft x 16-ft extruded aluminum sign panel
 on three 6-inch x 8-inch weakened wood
 support posts

Soil Type

Standard Soil of Crushed Limestone

Test Vehicle

Type/Designation 1100C
 Make and Model 2006 Kia Rio
 Curb 2532 lb
 Test Inertial 2432 lb
 Dummy 179 lb
 Gross Static 2611 lb

Impact Conditions

Speed 61.6 mi/h
 Angle 0 degrees
 Location/Orientation Right 2 supports

Exit Conditions

Speed Not attainable
 Angle ~0 degrees

Occupant Risk Values

Impact Velocity
 Longitudinal 8.5 ft/s
 Lateral 0.3 ft/s
 Ridedown Accelerations
 Longitudinal 2.0 G
 Lateral 1.0 G
 THIV 2.6 m/s
 PHD 2.0 G
 ASI 0.34
 Max. 0.050-s Average
 Longitudinal -3.8 G
 Lateral 0.6 G
 Vertical -2.3 G

Post-Impact Trajectory

Stopping Distance 196 ft dwnstrm

Vehicle Stability

Maximum Yaw Angle 2 degrees
 Maximum Pitch Angle 3 degrees
 Maximum Roll Angle 6 degrees
 Vehicle Snagging NA
 Vehicle Pocketing NA

Test Article Debris Pattern

Longitudinal 206 ft
 Lateral 16 ft

Vehicle Damage

VDS 12FD2
 CDC 12FDEW2
 Max. Exterior Deformation 1.0 inches
 OCDI FS01000000
 Max. Occupant Compartment
 Deformation Penetrated
 windshield

Figure 4.10. Summary of Results for MASH Test 3-61 on the Direct Embedded Wood Support Temporary Guide Sign System.

H. *Occupant impact velocities should satisfy the following:
Longitudinal and Lateral Occupant Impact Velocity*

<u>Preferred</u>	<u>Maximum</u>
10 ft/s	16.4 ft/s)

Results: Longitudinal occupant impact velocity was 8.5 ft/s, and lateral occupant impact velocity was 0.3 ft/s. (PASS)

I. *Occupant ridedown accelerations should satisfy the following:*

<u>Longitudinal and Lateral Occupant Ridedown Accelerations</u>	
<u>Preferred</u>	<u>Maximum</u>
15.0 Gs	20.49 Gs

Results: Maximum longitudinal ridedown acceleration was 2.0 G, and maximum lateral ridedown acceleration was 1.0 G. (PASS)

5.3.8.3 *Vehicle Trajectory*

N. *Vehicle trajectory behind the test article is acceptable.*

Result: The 1100C vehicle came to rest 196 ft behind the installation. (PASS)

4.4 DESIGN MODIFICATION

After analysis of the unacceptable high-speed test, TTI research engineers modified the design of the temporary large guide sign support system to address the identified problem. The objective was to change the rotation of the fractured support posts in high-speed impacts to permit the impacting vehicle to travel beneath the sign system without secondary windshield or roof contact.

Figure 4.11 presents the design concepts considered. The research team recommended the option 1 design modification. It involves drilling a small hole through the wood support parallel to the sign panel above and below the weakening hole. A ¼-inch diameter cable is used to form a loop through the holes. Upon fracture of the support through the upper weakening hole, the cable will restrict rotation of the support toward the impacting vehicle.

Option 2 is similar in concept to option 1. A steel strap is through bolted to each side of the wood support across the region containing the upper weakening hole. After fracture of the support member, the strap acts as a linkage and the support rotates about the lower bolt. The bottom of the support rotates upward without the top of the support dropping in elevation.

Option 3 incorporates a steel strap on the back side of the wood support that spans across the upper weakening hole. After fracture of the support, the strap bends and acts as a hinge plate. This is analogous to the original design used on steel post guide signs in which the support was partially cut through the front flange and web. A fuse plate was placed across the front flange. When the fuse plate fractured during impact, the post rotated about a hinge formed at the back flange. In this wood support variation, the fracture of the support is controlled by the weakening hole, and the strap becomes the hinge. The drawback of this system is that it is

unidirectional. It is designed to operate for a frontal impact but would not operate in the same mode for a backside impact. Therefore, this would not be the preferred option if the temporary wood post guide sign is intended for use in a median of a divided highway, or within the clear zone for opposing traffic on an undivided highway.

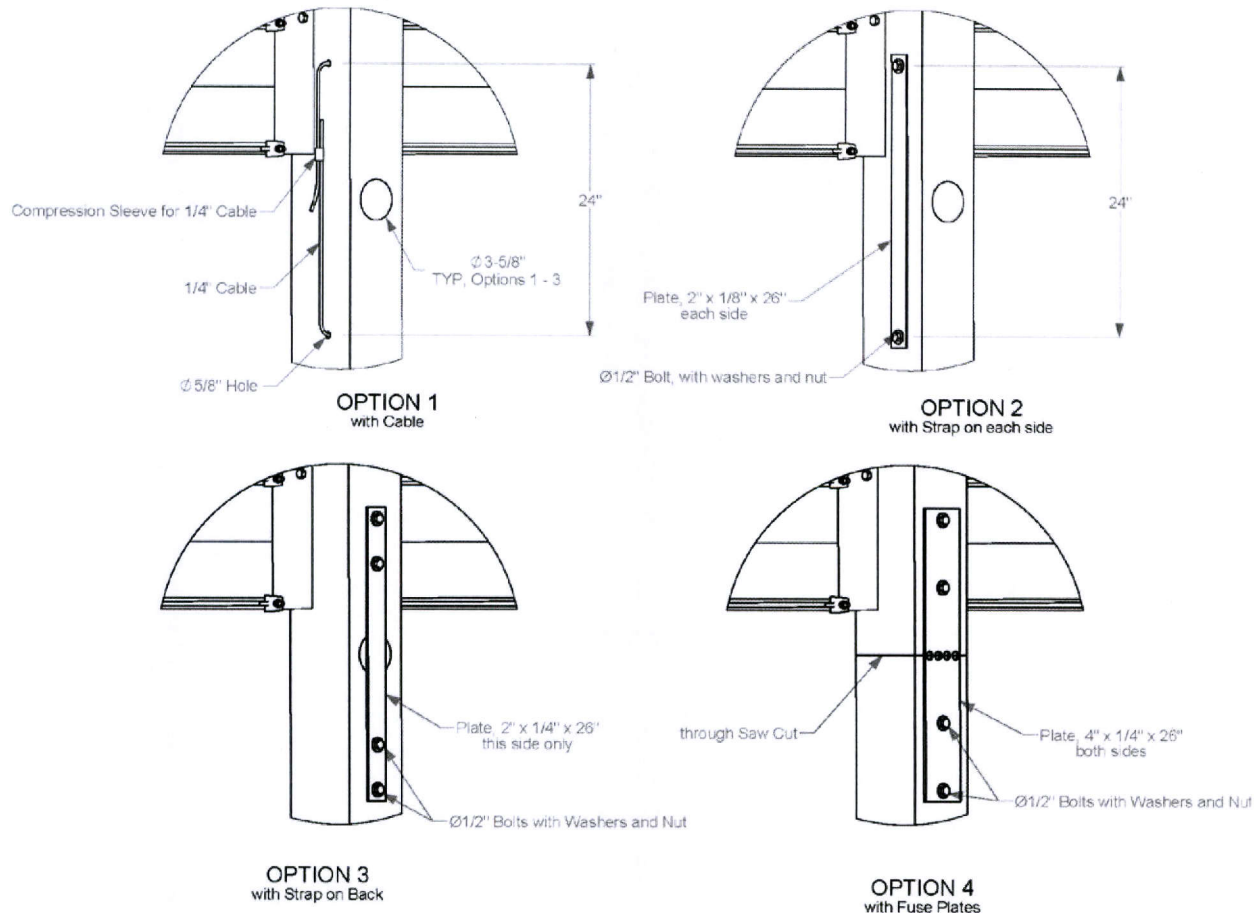

Figure 4.11. Design Options for Direct Embedded Wood Support Temporary Guide Sign System.

Option 4 is a fuse plate concept similar to that currently used on steel support systems. The wood support is saw cut through its entire cross section below the sign panel and is then reconnected by steel fuse plates on the front and back side of the posts. In this option, the fuse plate on the impact side fractures and the support rotates about the fuse plate on the opposite side of the post. The use of dual fuse plates makes this system bidirectional. Based on testing experience with steel post systems, the rear fuse plate may fracture during the impact sequence, but this would typically occur after the support hinges about the rear fuse plate and the vehicle has passed safely underneath the sign. This option is more complex and costly to fabricate and install than options 1 and 2.

In consultation with TxDOT, design option 1 was selected for further evaluation. Figure 4.12 provides overall details the modified direct embedded wood support temporary guide

sign system, and Appendix D includes further details. Figure 4.13 shows photographs of the installation prior to testing.

Crash testing was performed to evaluate the impact performance of the modified design. It was concluded that the low-speed car test (Test 3-60) did not need to be rerun. During the low-speed test, only one of the two impacted wood supports fractured at the upper weakening hole, and the other did not interact with the vehicle. When the two wood supports fractured at groundline, the sign rotated around the third support. The only interaction with the vehicle was the sign falling on top of the vehicle after being pried off the third support post. This behavior will not change by adding a hinge point for the fractured support post at the bottom of the sign. Therefore, the test matrix for the modified design consisted of two tests: test 3-61 (high-speed small car test) and test 3-62 (high-speed pickup truck test).

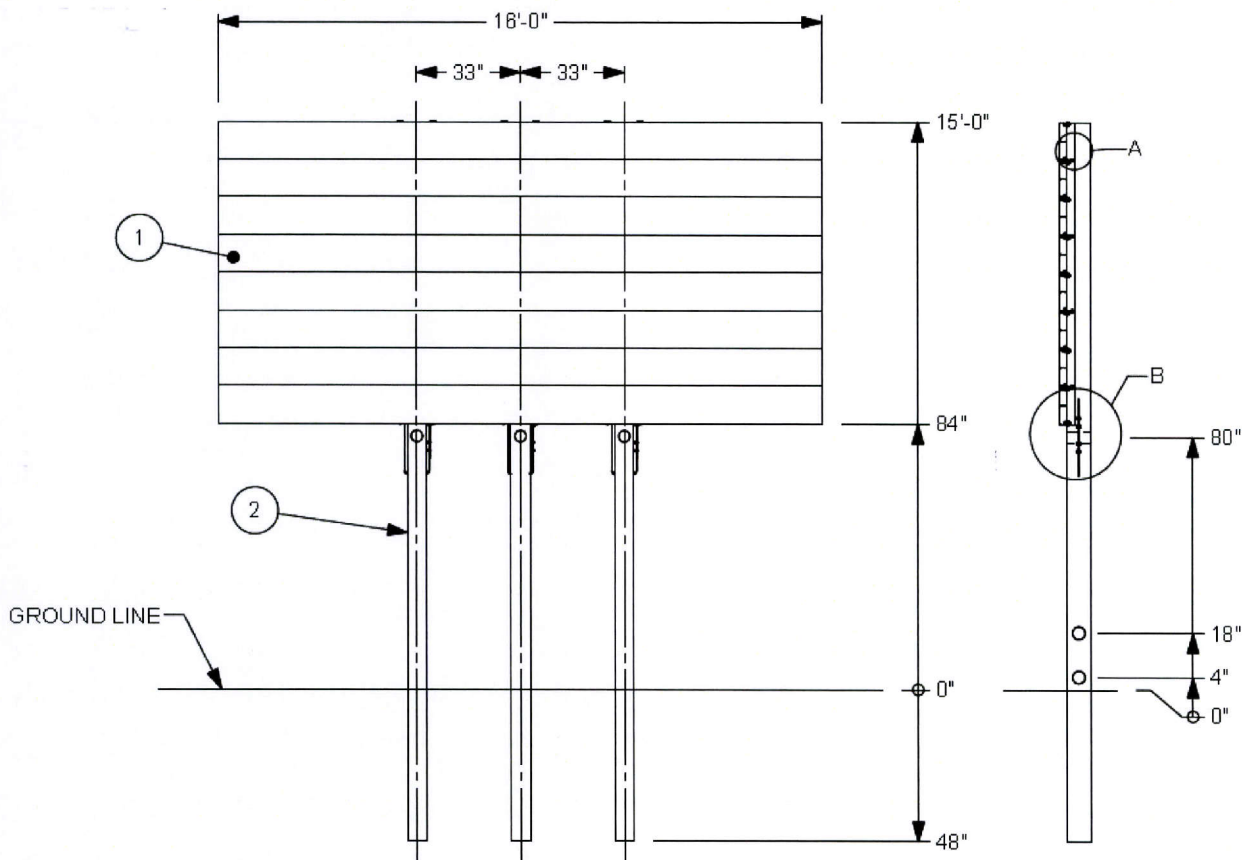

Figure 4.12. Modified Direct Embedded Wood Support Temporary Guide Sign System before Test No. 467823-2b.

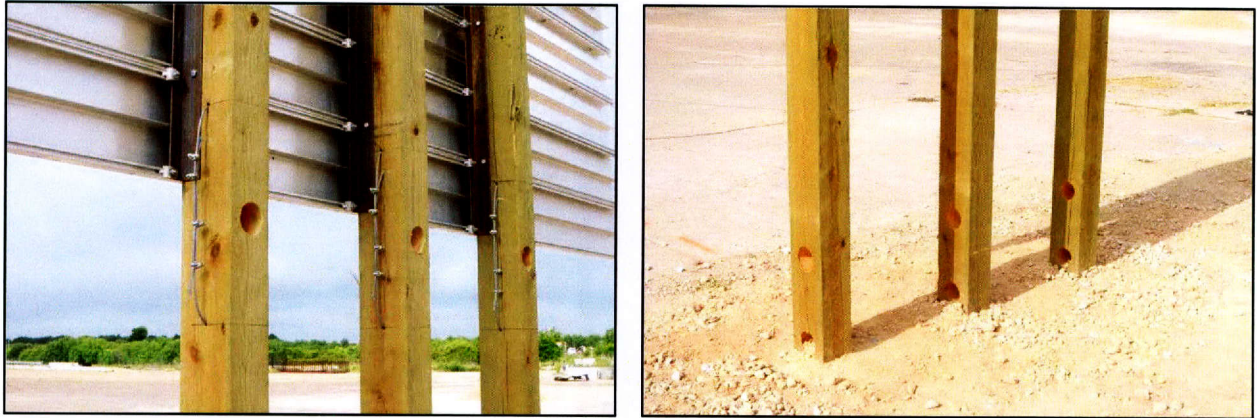

Figure 4.13. Modified Direct Embedded Wood Support Temporary Guide Sign System before Test Nos. 467823-2b and 467823-3.

4.5 MASH TEST 3-61 ON THE MODIFIED DIRECT EMBEDDED WOOD SUPPORT TEMPORARY GUIDE SIGN SYSTEM (TEST NO. 467823-2b)

4.5.1 Test Designation and Actual Impact Conditions

MASH Test 3-61 involves an 1100C vehicle weighing 2420 lb \pm 55 lb impacting the sign support at a speed of 62 mi/h \pm 2.5 mi/h and a critical impact angle of 0 degrees \pm 1.5 degrees. The target impact point was centerline of the vehicle aligned with the centerline between two of the three wooden supports. The 2006 Kia Rio used in the test had a test inertial weight of 2425 lb, and the actual impact speed and angle were 61.2 mi/h and 0 degrees, respectively. The actual impact point was centerline of the vehicle aligned with the centerline between the two supports on the right side of the sign support system.

4.5.2 Test Vehicle

Figure 4.14 shows the 2006 Kia Rio used for the crash test. Test inertia weight of the vehicle was 2425 lb, and its gross static weight was 2604 lb. The height to the lower edge of the vehicle bumper was 7.12 inches, and the height to the upper edge of the bumper was 21.0 inches. Table E1 in Appendix E gives additional dimensions and information on the vehicle. The vehicle was directed into the installation using the cable reverse tow and guidance system and was released to be free-wheeling and unrestrained just prior to impact.

4.5.3 Weather and Soil Conditions

The test was performed on the morning of June 13, 2013. Weather conditions at the time of testing were as follows: wind speed: 3 mi/h; wind direction: 198 degrees with respect to the vehicle (vehicle was traveling in a northerly direction); temperature: 82°F, relative humidity: 85 percent.

The test installation was installed in standard soil meeting AASHTO standard specifications for “Materials for Aggregate and Sol Aggregate Subbase, Base and Surface Courses,” designated M147-65(2004), grading B. In accordance with Appendix B of *MASH*, soil strength was measured the day of the crash test. The minimum post load required for deflections

at 5 inches, 10 inches, and 15 inches, measured at a height of 25 inches, is 3940 lb, 5500 lb, and 6540 lb, respectively (90% of static load for the initial standard installation). On the day of the test, June 13, 2013, load on the post at deflections of 5 inches, 10 inches, and 15 inches was 10,800 lbf, 11,575 lbf, and 11,787 lbf, respectively. The strength of the backfill material met minimum requirements.



Figure 4.14. Vehicle before Test No. 467823-2b.

4.5.4 Test Description

The 2006 Kia Rio, traveling at an impact speed of 61.6 mi/h, impacted the middle and right support legs of the sign support at an impact angle of 0 degrees. At approximately 0.005 s, the right support leg fractured at bumper height, and at 0.007 s the right support leg fractured just below the sign panel. The center support leg fractured at bumper height at 0.008 s, and fractured just below the sign panel at 0.015 s. At 0.031 s the vehicle lost contact with the right support leg, and at 0.056 s the vehicle lost contact with the center support leg while traveling at a speed of 56.7 mi/h. The fractured supports rotated upward about the restraining cables as designed, and the test vehicle past underneath the sign installation without any secondary contact. The inertia of the fractured rotating supports caused the sign to begin to rotate about the third support post. When the fractured rotating supports contacted the back of the sign panel, the resulting force caused the left support leg to fracture at the weakening hole below the extruded aluminum sign panel at 0.258 s. Brakes on the vehicle were applied at 0.6 s after impact, and the vehicle came to rest 212 ft behind the impact location. Figures E1 and E2 in Appendix E show sequential photographs of the test period.

4.5.5 Damage to Test Installation

Figure 4.15 shows damage to the wood post sign support system after the test. The right and middle support legs fractured at the holes at bumper height, near ground level, and below the sign panel as designed. The upper sections of right and middle support legs remained attached to the sign panel and to the fractured lower sections via the restraining cable. The left support leg fractured at the hole below the sign panel with minimal displacement in the soil. The sign panel remained attached to the lower section of the left support leg via the restraining cable.

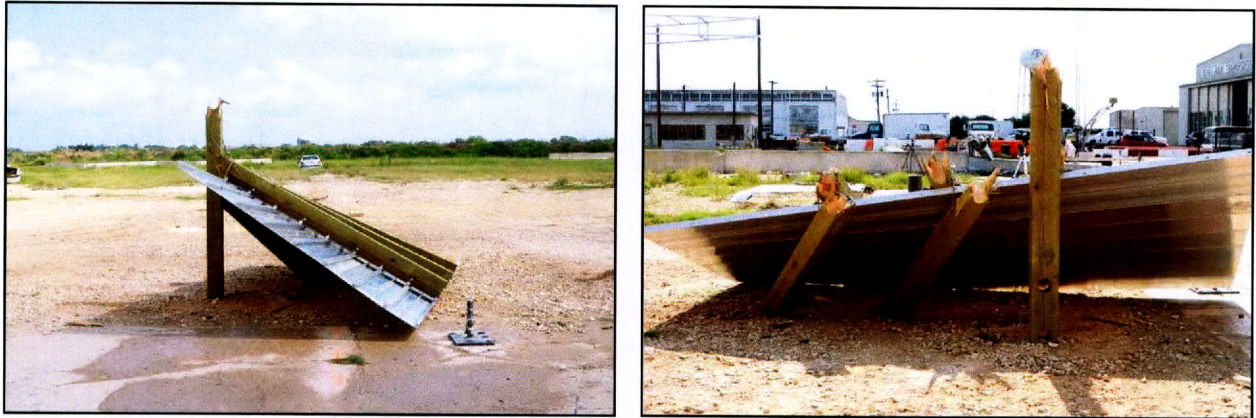

Figure 4.15. Modified Direct Embedded Wood Support Temporary Guide Sign System after Test No. 467823-2b.

4.5.6 Vehicle Damage

Figure 4.16 shows the damage sustained by the vehicle during the test, which included the front bumper, hood, radiator and radiator support. The front end was deformed 6.5 inches on the left of centerline and 3.0 inches on the right of centerline just below bumper height. No occupant compartment deformation or penetration occurred during the test. Exterior crush and occupant compartment measurements can be found in Tables E2 and E3 of Appendix E.

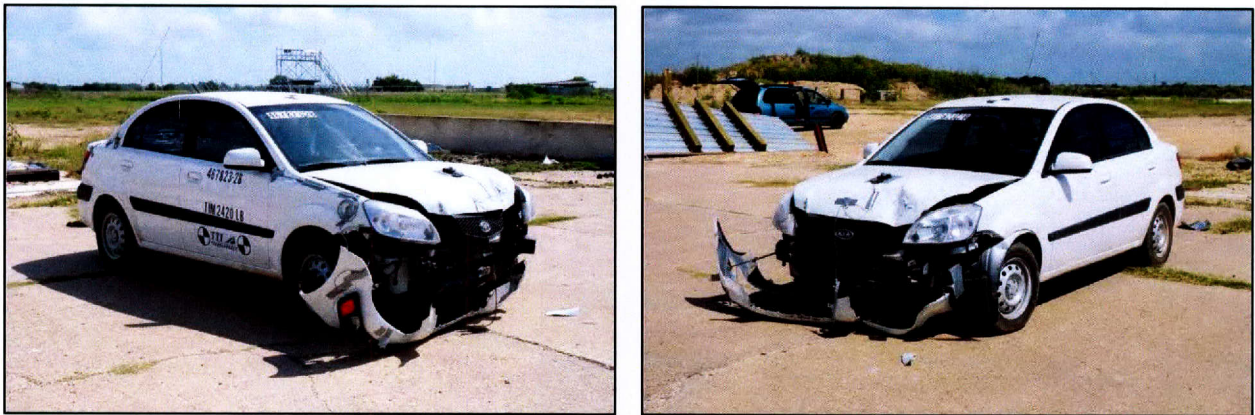

Figure 4.16. Vehicle after Test No. 467823-2.

4.5.7 Occupant Risk Factors

Data from the accelerometer located at the vehicle center of gravity were digitized for evaluation of occupant risk. In the longitudinal direction, the occupant impact velocity was 6.9 ft/s at 0.301 s, the highest 0.010-s occupant ridedown acceleration was 1.4 Gs from 0.930 to 0.940 s, and the maximum 0.050-s average acceleration was -3.9 Gs between 0.000 and 0.050 s. In the lateral direction, the occupant impact velocity was 1.0 ft/s at 0.301 s, the highest 0.010-s occupant ridedown acceleration was 0.8 Gs from 0.838 to 0.848 s, and the maximum 0.050-s average was 0.9 Gs between 0.020 and 0.070 s. Theoretical Head Impact Velocity was 7.7 km/h or 2.1 m/s at 0.301 s; Post-Impact Head Decelerations was 1.4 Gs between 0.930 and 0.940 s; and Acceleration Severity Index was 0.33 between 0.000 and 0.050 s. Figure 4.17 summarizes

these data and other pertinent information from the test. Vehicle angular displacements and accelerations versus time traces are presented in Appendix E, Figures E3 through E9.

4.5.8 Assessment of Test Results

An assessment of the test based on the applicable *MASH* safety evaluation criteria is provided below.

4.5.8.1 Structural Adequacy

B. The test article should readily activate in a predictable manner by breaking away, fracturing, or yielding.

Results: The modified direct embedded wood post support system for temporary guide signs activated readily by fracturing upon impact and hinging about the cable attachment. (PASS)

4.5.8.2 Occupant Risk

D. Detached elements, fragments, or other debris from the test article should not penetrate or show potential for penetrating the occupant compartment, or present an undue hazard to other traffic, pedestrians, or personnel in a work zone.

Deformation of, or intrusions into, the occupant compartment should not exceed limits set forth in Section 5.3 and Appendix E of MASH. (roof ≤ 4.0 inches; windshield = ≤ 3.0 inches; side windows = no shattering by test article structural member; wheel/foot well/toe pan ≤ 9.0 inches; forward of A-pillar ≤ 12.0 inches; front side door area above seat ≤ 9.0 inches; front side door below seat ≤ 12.0 inches; floor pan/transmission tunnel area ≤ 12.0 inches).

Results: The fractured sections of the wooden supports remained attached via the restraining cables and did not penetrate or show potential for penetrating the occupant compartment, or to present hazard to others in the area.

(PASS)

No occupant compartment penetration or deformation occurred. (PASS)

F. The vehicle should remain upright during and after collision. The maximum roll and pitch angles are not to exceed 75 degrees.

Results: The 1100C vehicle remained upright during and after the collision event. Maximum roll and pitch angles were 1.4 degrees and 15 degrees, respectively. (PASS)

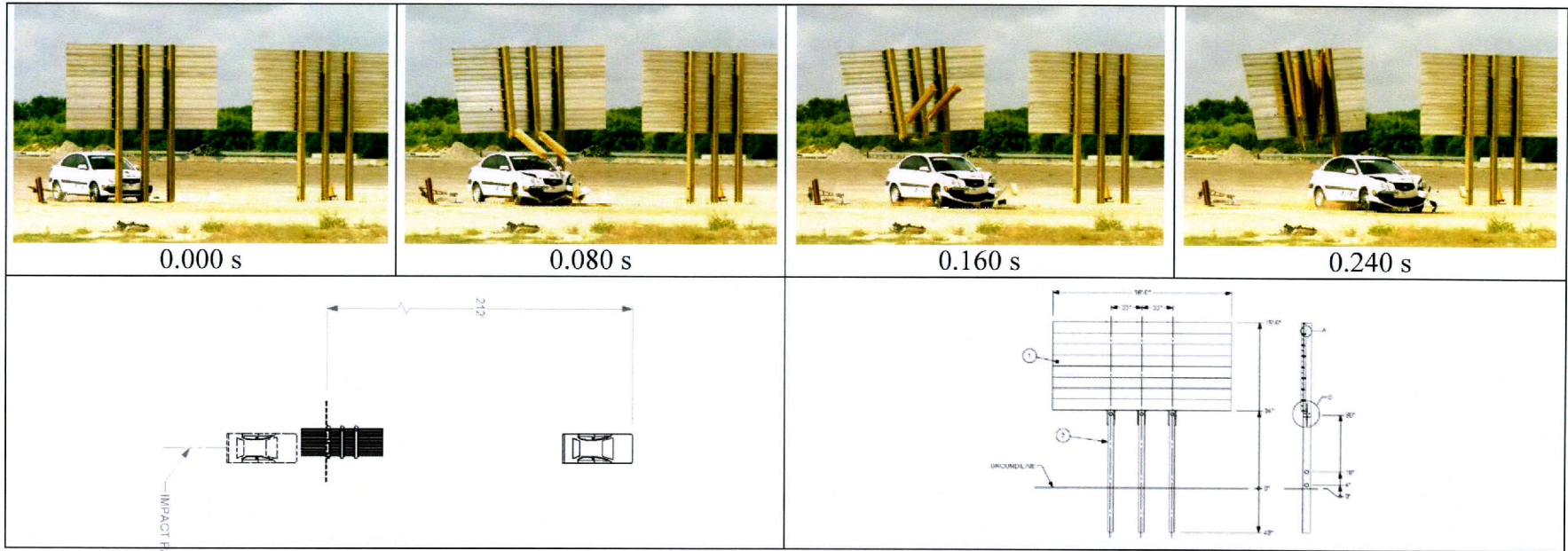

General Information

Test Agency Texas A&M Transportation Institute (TTI)
 Test Standard Test No. MASH Test 3-61
 TTI Test No. 467823-2b
 Test Date 2013-06-24

Test Article

Type Sign Support
 Name TxDOT Direct Embedded Wood Support
 Temporary Guide Sign System

Installation Mounting Height 7 ft
 Material or Key Elements 8-ft x 16-ft extruded aluminum sign on
 three 6-inch x 8-inch weakened wood
 supports with restraining cable
 Soil Type Standard Soil of Crushed Limestone

Soil Type

Test Vehicle

Type/Designation 1100C
 Make and Model..... 2006 Kia Rio
 Curb 2353 lb
 Test Inertial 2425 lb
 Dummy..... 179 lb
 Gross Static..... 2604 lb

Impact Conditions

Speed 61.2 mi/h
 Angle 0 degrees
 Location/Orientation Right 2 supports

Exit Conditions

Speed Not attainable
 Angle ~0 degrees

Occupant Risk Values

Impact Velocity
 Longitudinal..... 6.9 ft/s
 Lateral..... 1.0 ft/s
 Ridedown Accelerations
 Longitudinal..... 1.4 G
 Lateral..... 0.8 G
 THIV 2.1 m/s
 PHD 1.4 G
 ASI 0.33

Max. 0.050-s Average

Longitudinal..... -3.9 G
 Lateral..... 0.9 G
 Vertical..... -2.8 G

Post-Impact Trajectory

Stopping Distance 212 ft dwnstrm

Vehicle Stability

Maximum Yaw Angle..... 2 degrees
 Maximum Pitch Angle..... 15 degrees
 Maximum Roll Angle..... 1 degrees
 Vehicle Snagging NA
 Vehicle Pocketing NA

Test Article Debris Pattern

Longitudinal..... 54 ft
 Lateral 16 ft

Vehicle Damage

VDS 12FD3
 CDC 12FDEW3
 Max. Exterior Deformation 6.5 inches
 OCDI FS0000000
 Max. Occupant Compartment
 Deformation..... None

Figure 4.17. Summary of Results for MASH Test 3-61 on the Modified Direct Embedded Wood Support Temporary Guide Sign System.

H. *Occupant impact velocities should satisfy the following:*
Longitudinal and Lateral Occupant Impact Velocity

<u>Preferred</u>	<u>Maximum</u>
10 ft/s	16.4 ft/s)

Results: Longitudinal occupant impact velocity was 6.9 ft/s, and lateral occupant impact velocity was 1.0 ft/s. (PASS)

I. *Occupant ridedown accelerations should satisfy the following:*

Longitudinal and Lateral Occupant Ridedown Accelerations

<u>Preferred</u>	<u>Maximum</u>
15.0 Gs	20.49 Gs

Results: Maximum longitudinal ridedown acceleration was 1.4 G, and maximum lateral ridedown acceleration was 0.8 G. (PASS)

4.5.8.3 *Vehicle Trajectory*

N. *Vehicle trajectory behind the test article is acceptable.*

Result: The 1100C vehicle came to rest 212 ft behind the installation. (PASS)

4.6 **MASH TEST 3-62 ON THE MODIFIED DIRECT EMBEDDED WOOD SUPPORT TEMPORARY GUIDE SIGN SYSTEM (TEST NO. 467823-3)**

4.6.1 **Test Designation and Actual Impact Conditions**

MASH Test 3-62 involves a 2270P vehicle weighing 5000 lb \pm 110 lb impacting the sign support at an impact speed of 62 mi/h \pm 2.5 mi/h and a critical impact angle of 0 degrees \pm 1.5 degrees. The target impact point was centerline of the vehicle aligned with the centerline between two supports. The 2007 Dodge Ram 1500 used in the test had a test inertial weight of 5015 lb, and the actual impact speed and angle were 64.0 mi/h and 0 degrees, respectively. The actual impact point was centerline of the vehicle aligned with centerline between the two supports on the left side.

4.6.2 **Test Vehicle**

Figure 4.18 shows the 2007 Dodge Ram 1500 pickup truck used for the crash test. Test inertia weight of the vehicle was 5015 lb, and its gross static weight was 5015 lb. The height to the lower edge of the vehicle bumper was 15.5 inches, and the height to the upper edge of the bumper was 28.0 inches. The height to the center of gravity was 28.38 inches. Tables F1 and F2 in Appendix F gives additional dimensions and information on the vehicle. The vehicle was directed into the installation using the cable reverse tow and guidance system, and was released to be free-wheeling and unrestrained just prior to impact.

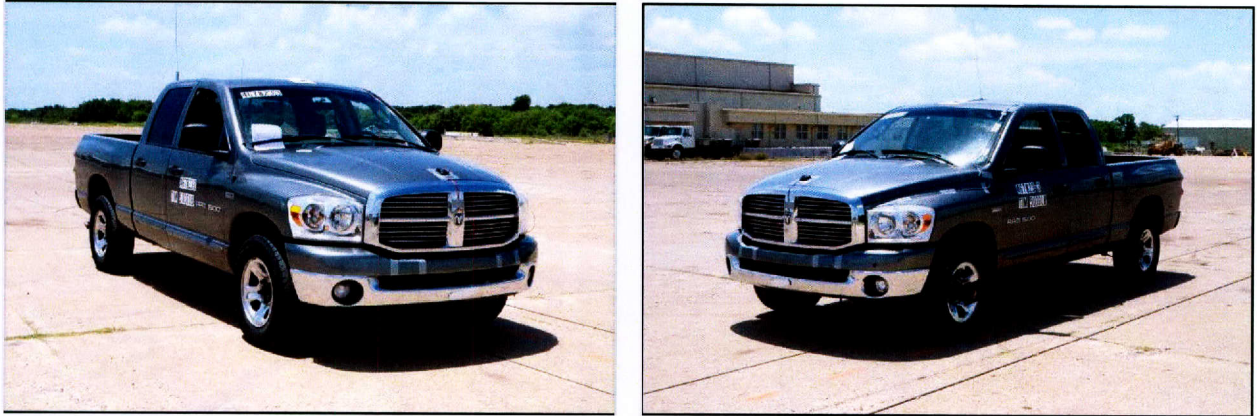

Figure 4.18. Vehicle before Test No. 467823-3.

4.6.3 Weather and Soil Conditions

The test was performed on the afternoon of June 13, 2013. Weather conditions at the time of testing were as follows: wind speed: 2 mi/h; wind direction: 179 degrees with respect to the vehicle (vehicle was traveling in a northerly direction); temperature: 92°F, relative humidity: 59 percent.

The test installation was installed in standard soil meeting AASHTO standard specifications for “Materials for Aggregate and Sol Aggregate Subbase, Base and Surface Courses,” designated M147-65(2004), grading B. In accordance with Appendix B of *MASH*, soil strength was measured the day of the crash test. The minimum post load required for deflections at 5 inches, 10 inches, and 15 inches, measured at a height of 25 inches, is 3940 lb, 5500 lb, and 6540 lb, respectively (90% of static load for the initial standard installation). On the day of the test, June 13, 2013, load on the post at deflections of 5 inches, 10 inches, and 15 inches was 8363 lbf, 8363 lbf, and 8212 lbf, respectively. The strength of the backfill material met minimum requirements.

4.6.4 Test Description

The 2007 Dodge Ram 1500 pickup truck, traveling at an impact speed of 64.0 mi/h, impacted the middle and left support legs of the sign support at an impact angle of 0 degrees. At approximately 0.003 s, the left and center support legs began to fracture at bumper height, and at 0.004 s, the left and center support legs began to fracture just below the sign panel. The fractured support legs hinged about the restraining cables as designed, and the vehicle lost contact with both support legs at 0.044 s. As the vehicle continued to travel forward, pieces of wood projecting from the fractured end of the support posts contacted the windshield and roof of the pickup truck, but there was no damage to or penetration of the windshield. The sign panel rotated clockwise, pried off of the right support leg, and fell to the ground. Brakes on the vehicle were applied at 0.38 s after impact, and the vehicle came to rest 224 ft behind the impact location. Figures F1 and F2 in Appendix F show sequential photographs of the test period.

4.6.5 Damage to Test Installation

Figure 4.19 shows damage to the wood post sign support after the test. The left and middle support legs fractured at the holes at bumper height, near ground level, and below the sign panel. The upper sections of fractured support legs remained attached to the sign panel and to the fractured lower sections via the restraining cables. The right support leg remained intact with minimal movement in the soil. The sign panel separated from the right support leg and fell to the ground.

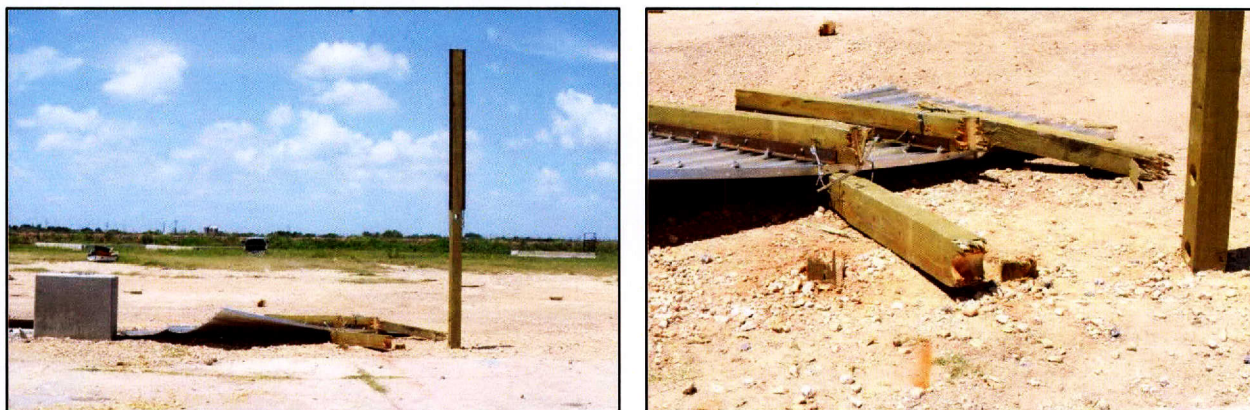

Figure 4.19. Modified Direct Embedded Wood Support Temporary Guide Sign System after Test No. 467823-3.

4.6.6 Vehicle Damage

Figure 4.20 shows the damage sustained by the vehicle during the test, which included the front bumper, hood, and roof. The front of the vehicle was deformed 1.0 inch both left and right of centerline of the vehicle at bumper height. There were two small dents in the roof, one measuring 1.5 inches wide \times 26 inches long \times 1.12 inches deep, and another 2.5 inches wide \times 25 inches long and 0.25 inch deep. No occupant compartment deformation or penetration occurred during the test. Exterior crush and occupant compartment measurements can be found in Tables F3 and F4 of Appendix F.

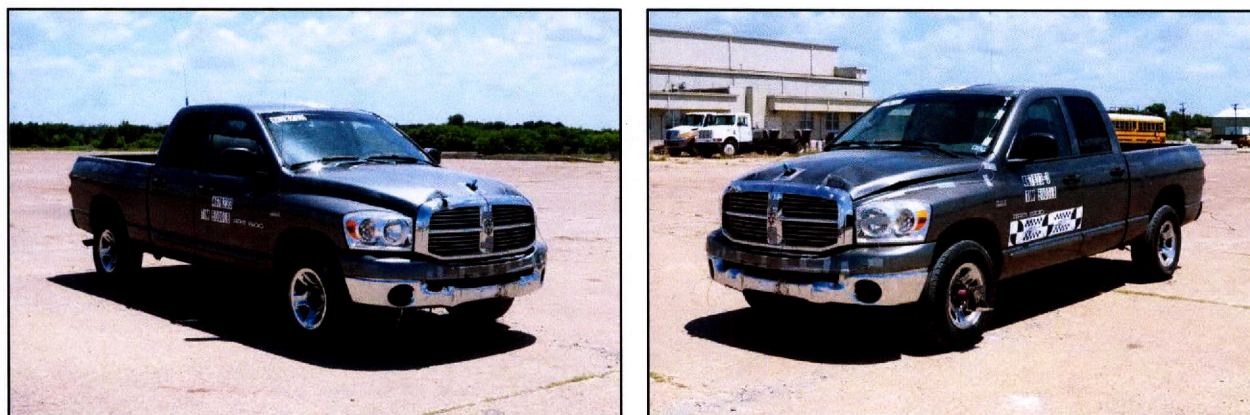

Figure 4.20. Vehicle after Test No. 467823-3.

4.6.7 Occupant Risk Factors

Data from the accelerometer, located at the vehicle center of gravity, were digitized for evaluation of occupant risk. In the longitudinal direction, the occupant impact velocity was 4.6 ft/s at 0.553 s, the highest 0.010-s occupant ridedown acceleration was 1.5 Gs from 0.782 to 0.792 s, and the maximum 0.050-s average acceleration was -1.9 Gs between 0.000 and 0.050 s. In the lateral direction, the occupant impact velocity was 1.3 ft/s at 0.553 s, the highest 0.010-s occupant ridedown acceleration was 1.0 Gs from 0.583 to 0.593 s, and the maximum 0.050-s average was -0.9 Gs between 0.291 and 0.341 s. Theoretical Head Impact Velocity was 5.2 km/h or 1.4 m/s at 0.554 s; Post-Impact Head Decelerations was 1.5 Gs between 0.782 and 0.792 s; and Acceleration Severity Index was 0.16 between 0.000 and 0.050 s. Figure 4.21 summarizes these data and other pertinent information from the test. Vehicle angular displacements and accelerations versus time traces are presented in Appendix F, Figures F3 through F9.

4.6.8 Assessment of Test Results

An assessment of the test based on the applicable *MASH* safety evaluation criteria is provided below.

4.6.8.1 Structural Adequacy

B. *The test article should readily activate in a predictable manner by breaking away, fracturing, or yielding.*

Results: The modified direct embedded wood post support system for temporary guide signs readily activated by fracturing upon impact. (PASS)

4.6.8.2 Occupant Risk

D. *Detached elements, fragments, or other debris from the test article should not penetrate or show potential for penetrating the occupant compartment, or present an undue hazard to other traffic, pedestrians, or personnel in a work zone.*

Deformation of, or intrusions into, the occupant compartment should not exceed limits set forth in Section 5.3 and Appendix E of MASH. (roof ≤ 4.0 inches; windshield = ≤ 3.0 inches; side windows = no shattering by test article structural member; wheel/foot well/toe pan ≤ 9.0 inches; forward of A-pillar ≤ 12.0 inches; front side door area above seat ≤ 9.0 inches; front side door below seat ≤ 12.0 inches; floor pan/transmission tunnel area ≤ 12.0 inches).

Results: The fractured sections of supports remained attached via restraining cables and did not penetrate or show potential for penetrating the occupant compartment, or to present hazard to others in the area. (PASS)
No occupant compartment penetration or deformation occurred. (PASS)

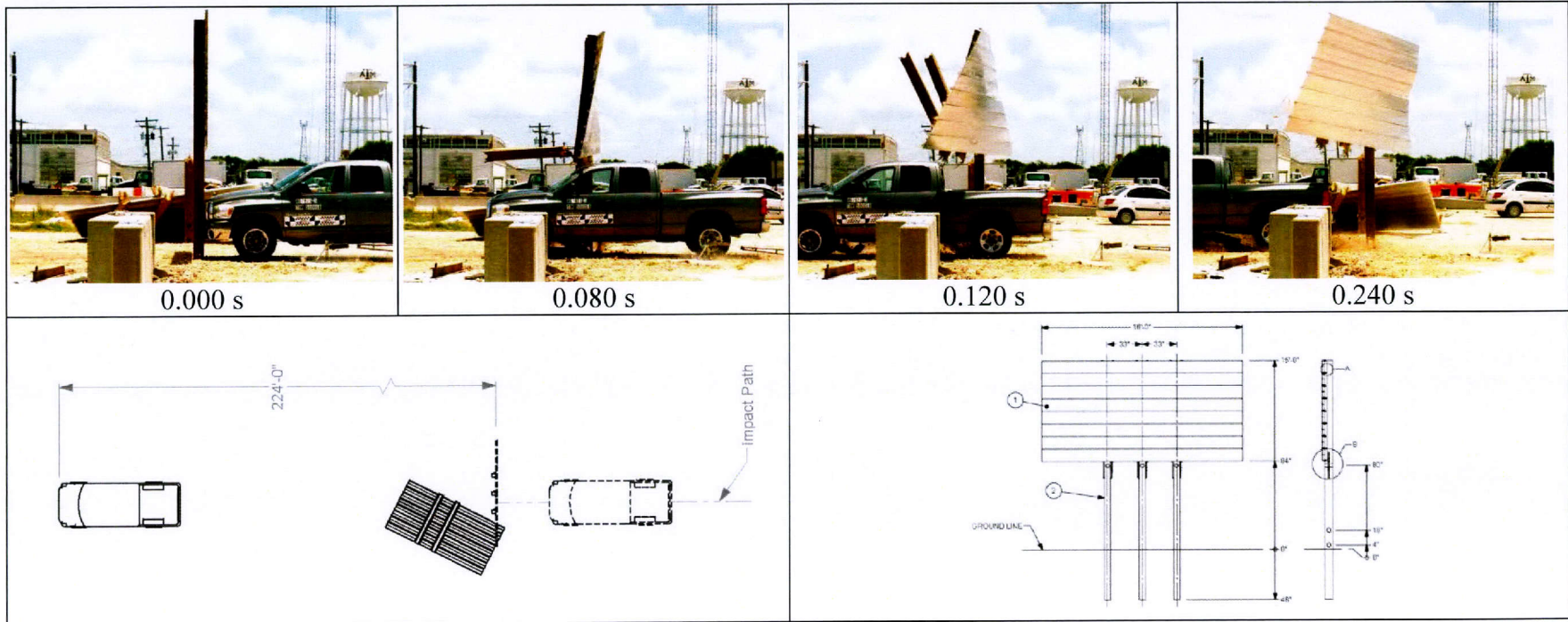

General Information

Test Agency Texas A&M Transportation Institute (TTI)
 Test Standard Test No. MASH Test 3-62
 TTI Test No. 467823-3
 Test Date 2013-06-24

Test Article

Type Sign Support
 Name TXDOT Direct Embedded Wood Support
 Temporary Guide Sign System
 Installation Mounting Height 7 ft
 Material or Key Elements 8-ft x 16-ft extruded aluminum sign on
 three 6-inch x 8-inch weakened wood
 support posts with restraining cable

Soil Type

Standard Soil of Crushed Limestone

Test Vehicle

Type/Designation 2270P
 Make and Model 2007 Dodge Ram 1500 Pickup
 Curb 5015 lb
 Test Inertial 5015 lb
 Dummy No dummy
 Gross Static 5015 lb

Impact Conditions

Speed 64.0 mi/h
 Angle 0 degrees
 Location/Orientation Left 2 supports

Exit Conditions

Speed Not obtainable
 Angle ~0 degrees

Occupant Risk Values

Impact Velocity
 Longitudinal 4.6 ft/s
 Lateral 1.3 ft/s
 Ridedown Accelerations
 Longitudinal 1.5 G
 Lateral 1.0 G
 THIV 1.4 m/s
 PHD 1.5 G
 ASI 0.16
 Max. 0.050-s Average
 Longitudinal -1.9 G
 Lateral -0.9 G
 Vertical 1.1 G

Post-Impact Trajectory

Stopping Distance 224 ft downstrm

Vehicle Stability

Maximum Yaw Angle 3 degrees
 Maximum Pitch Angle 1 degree
 Maximum Roll Angle 3 degrees
 Vehicle Snagging No
 Vehicle Pocketing No

Test Article Debris Pattern

Longitudinal 30 ft
 Lateral 20 ft

Vehicle Damage

VDS 12FD1
 CDC 12FDEW1
 Max. Exterior Deformation 1.0 inch
 OCDI FS000000
 Max. Occupant Compartment
 Deformation None

Figure 4.21. Summary of Results for MASH Test 3-62 on the Modified Direct Embedded Wood Support Temporary Guide Sign System.

F. *The vehicle should remain upright during and after collision. The maximum roll and pitch angles are not to exceed 75 degrees.*

Results: The 2270P vehicle remained upright during and after the collision event. Maximum roll and pitch angles were 3 degrees and 1 degree, respectively. (PASS)

H. *Occupant impact velocities should satisfy the following:*
Longitudinal and Lateral Occupant Impact Velocity

<u>Preferred</u>	<u>Maximum</u>
10 ft/s	16.4 ft/s

Results: Longitudinal occupant impact velocity was 4.6 ft/s, and lateral occupant impact velocity was 1.3 ft/s. (PASS)

I. *Occupant ridedown accelerations should satisfy the following:*

Longitudinal and Lateral Occupant Ridedown Accelerations

<u>Preferred</u>	<u>Maximum</u>
15.0 Gs	20.49 Gs

Results: Maximum longitudinal ridedown acceleration was 1.5 G, and maximum lateral ridedown acceleration was 1.0 G. (PASS)

4.6.8.3 *Vehicle Trajectory*

N. *Vehicle trajectory behind the test article is acceptable.*

Result: The 2270P vehicle came to rest 224 ft behind the installation. (PASS)

CHAPTER 5. DESIGN AND TESTING OF DIRECT EMBEDDED STEEL SUPPORT TEMPORARY GUIDE SIGN SYSTEM

The use of direct embedded steel foundation posts allows for existing large guide signs with steel supports to be economically and temporarily relocated without the need for installing expensive and hard to remove concrete foundations. Providing an option for driven supports significantly reduces installation cost and time compared to drilling and pouring a concrete foundation pier. It also eliminates the required cure time associated with a concrete foundation, thereby permitting the foundation and sign structure to be installed during the same site visit.

The new steel support foundation systems were developed to be compatible with existing large guide sign support details, and easy to install, remove, and reuse. Due consideration was given to accommodating wind loads and meeting the impact performance requirements of *MASH*. Although the direct embedded steel sign support system was developed with relocation of existing sign structures in mind, it is also a viable option for new signs implemented as part of a roadway construction project. It may be cost-effective to use galvanized steel foundation posts and supports for common signs such as the “Give Us a Brake” sign that can be reused from project to project.

5.1 FOUNDATION POST DESIGN

The design approach used for the direct embedded steel support system was to match the size of the steel foundation post to the size of the steel support member and determine an appropriate embedment depth based on the moment capacity of the support. With this approach, a design engineer need not be concerned with factors such as ground-to-sign mounting height, design wind speed, sign size, and aspect ratio.

As discussed in Section 2.4, the AASHTO *Standard Specifications for Structural Supports for Highway Signs, Luminaires, and Traffic Signals (1)* suggests use of Brom’s method for design of foundations for sign supports. This method has two complimentary models for analyzing foundation requirements. One model is recommended for the design of foundations in cohesionless soils such as sand, and the other is intended to be used for cohesive soils such as clay.

Figure 2.2 illustrates the foundation analysis model for cohesive soils. In the steel foundation post analyses, the moment (M) applied to the foundation was based on the flexural strength of the support member, which is calculated by multiplying the yield stress of a steel support by its section modulus. This provides a conservative analysis because the capacity of the support is typically controlled by a failure mode with a lower applied force/moment. These failure modes include lateral-torsional buckling of the support, failure of the fuse plate below the sign panel, or failure of the slip base components near the groundline. Note that the shear (V) used in the analyses was calculated by dividing the moment capacity of the support by the distance to the centroid of the sign (i.e., moment arm).

The equations below were used to determine the minimum embedment depth (L) for the foundation post. The analyses were performed for two different heights to the centroid of the sign – 11 ft and 14 ft. The difference in height to the sign centroid accounts for different mounting heights associated with different roadside terrain conditions. For example, the 11-ft sign centroid height could correspond to an 8-ft tall sign mounted at a height of 7 ft from the ground to the bottom of the sign. The 14-ft sign centroid could represent the same sign with an increased ground mounting height of 10 ft due to the presence of a roadside slope.

$$V_f = V_{req} * SF$$

$$M_f = M_{req} * SF$$

$$L = 1.5 * D + q \left[1 + \sqrt{2 + \frac{4 * H + 6 * D}{q}} \right]$$

$$H = \frac{M_f}{V_f}$$

$$q = \frac{V_f}{9 * c * D}$$

Table 5.1 presents the results of the analyses. Note that a value of 3100 psf was used for the undrained shear strength of the soil, ‘c.’ This value is representative of many clay soils throughout Texas, including the native clay found at TTI’s Riverside Campus.

Table 5.1. Recommended Embedment Depths for Selected Steel Supports.

Post Size	Embedment Depth (ft)			
	Hw (ft)		Average	Recommended
	11	14		
W6x9	3.4	3.4	3.4	3.5
W6x12	3.9	3.8	3.8	4.0
W6x15	4.0	3.9	3.9	4.0
W8x18	5.0	4.9	5.0	5.0
W8x21	5.4	5.3	5.4	5.5
W10x22	5.9	5.8	5.9	6.0
W10x26	6.5	6.3	6.4	6.5
W12x26	6.8	6.6	6.7	6.5
S3x5.7	2.3	2.3	2.3	2.5

The height to the centroid of the sign, Hw, had little influence on the calculated embedment depth. This is due to the fact that the embedment analysis is controlled by the moment, and Hw only affects the shear force. The recommended embedment depth for each

support size was, therefore, calculated by averaging the embedments calculated for each sign centroid height and then rounding to the nearest 6-inch increment.

To relocate an existing sign using the direct embedded steel foundation posts, the only information that is required is the size of the sign support members. The foundation posts match the size of the support posts, and the required embedment depth for the foundation post is taken from Table 6.1. The foundations posts include a standard slip base assembly above ground that mates with matching slip base plates on the steel support posts. If the supports will be placed in non-cohesive soils it is recommended that the foundation embedment depth be reanalyzed using Brom's method for cohesionless soils.

5.2 STATIC TESTING ON DIRECT EMBEDDED STEEL FOUNDATION POSTS

The suitability of the recommended embedment depths was evaluated through static load testing. The purpose of the static load testing was to verify the calculated foundation capacity. The steel foundation posts selected for evaluation in the static testing program included S3×5.7, W6×9, and W8×18. As shown in Table 5.1, these support posts have embedment depths of 2.5 ft, 3.5 ft, and 5.0 ft, respectively. These steel support sizes represent commonly used sections for large guide signs and provide a range of moment capacities for verification of the analytical procedures used to design the foundation posts.

The full-scale static tests were performed at the TTI Proving Ground located at the Texas A&M University Riverside Campus. The selected steel foundation posts with slip base plates were installed by auguring a hole to the desired depth and backfilling with a crushed limestone road base material. The soil surrounding the augured hole was native clay. A strong tubular steel support post with corresponding steel slip base plates was bolted to the slip base assembly for each foundation post.

A horizontal load was applied to the tubular steel post at a height 11 ft above grade using a hydraulic ram. The height of load application was selected to be representative of application of load (shear and moment) from a wind load event on a sign panel in a field installation. The applied force was measured using a load cell, and the post displacement at the height of the applied load was measured using a string pot.

Table 5.2 shows the calculated capacities of different steel post sections and their respective slip bases. These capacities were calculated under TxDOT Research Project 0-6363. For the sections selected for use in the static load test program, post controlled the capacity rather than the slip base. The desired objective was for the moment capacity of the foundation post to meet or exceed the moment capacity of the corresponding support post given in Table 5.2.

Figure 5.1 shows the force-deflection plots obtained from the static tests. In the test of the S3×5.7 foundation post, the post failed in lateral torsional buckling at a peak force of 0.82 kips. Given the force was applied at a height of 11 ft above grade, the resulting moment capacity is $0.82 \text{ kips} \times 11 \text{ ft} = 9.0 \text{ kip-ft}$. This value significantly exceeds the post capacity of 1.7 kip-ft.

Table 5.2. Calculated Capacities of Steel Posts and Corresponding Slip Bases (6).

Post Size	Slip Base Capacity (kip-ft)	Post Capacity (kip-ft)
W12x26	80.3	80.3
W10x26	70.1	68.7
W10x22	69.6	57.0
W8x21	59.3	43.7
W8x18	38.8	36.4
W6x15	30.7	24.2
W6x12	30.9	15.6
W6x9	30.4	11.8
S4x7.7	14.3	3.8
S3x5.7	14.3	1.7

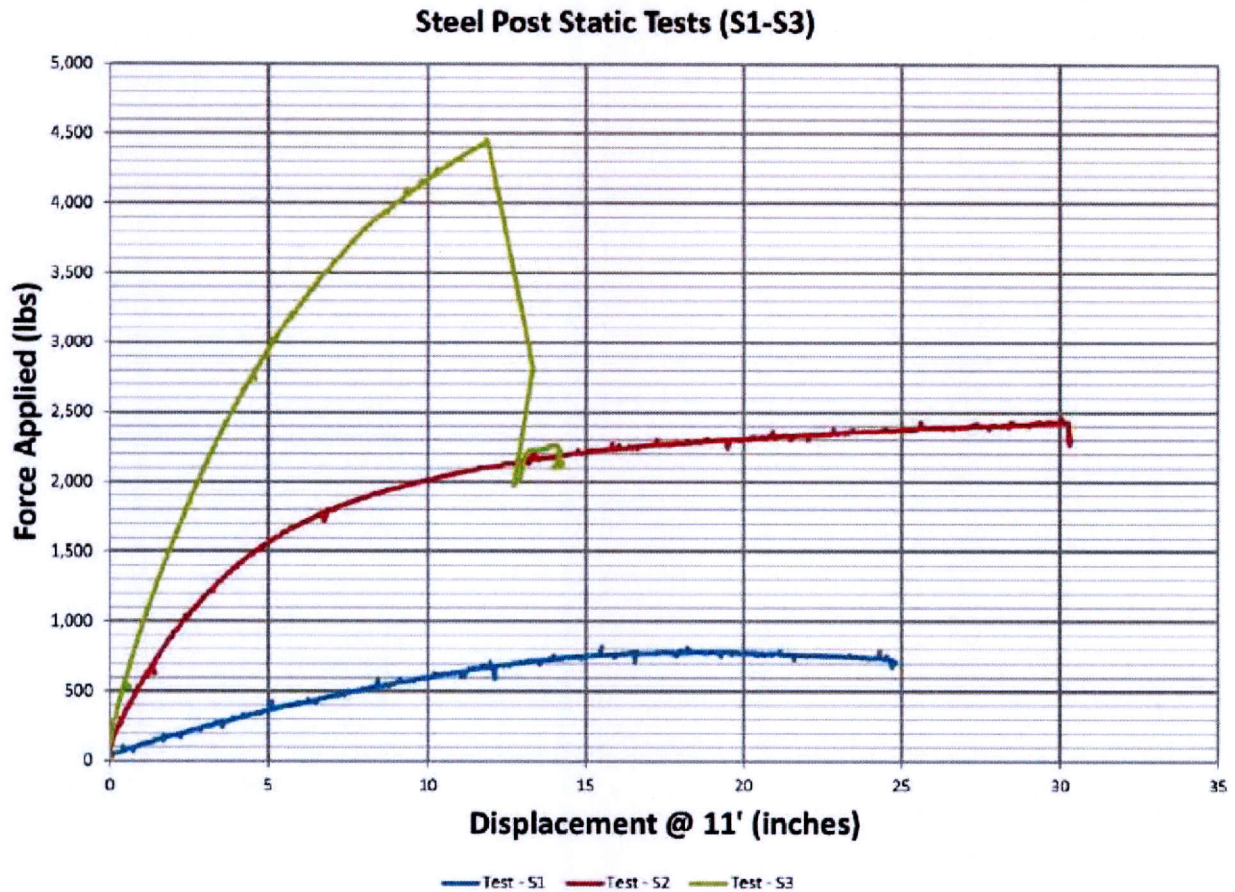

Figure 5.1. Static Test Results for S3×5.7 (Test S1), W6×9 (Test S2), and W8×18 (Test S3).

In the test of the W6×9 post, the force-deflection curve was leveling off, and the test was halted due to significant deflection. The peak force at the time the test was halted was 2.46 kips. The corresponding moment capacity is 27.1 kip-ft, which is more than twice the post capacity of 11.8 kip-ft from Table 5.2.

In the test of the W8×18 foundation post, the test was halted when a weld on the slip base failed on the tension side of the post. The maximum force reached at time of failure was 4.45 kips. This corresponds to a moment capacity of 49.0 kip-ft, which exceeds the 36.4 kip-ft moment capacity of a W8×18 post section.

In summary, the measured static load capacity of all three foundation posts exceeded the calculated moment capacities of the corresponding steel support posts. This verifies the analytical procedure used to design the foundation posts and indicates the suitability of the foundation posts for the temporary installation of large guide signs.

5.3 TEST ARTICLE DESIGN AND CONSTRUCTION FOR CRASH TESTING

As noted above, the direct embedded steel foundation system could utilize various post sizes based on the support members required for a given sign configuration. Obviously, resources are insufficient to crash test all of these foundation post sizes. The approach followed under this project was to select a critical configuration from among the most commonly used support sizes. A successful test of the critical post size will provide the basis for acceptance of other less critical configurations.

The system selected for testing was an 8-ft × 16-ft extruded aluminum sign panel supported by two W6×9 steel posts at a mounting height of 7 ft from the ground to the bottom of the sign panel. Figure 5.2 provides overall details of the system, and construction details are provided in Appendix G. Figure 5.3 shows photographs of the completed installation.

The foundation posts will match the size of the support posts (i.e., W6×9) and will be directly embedded 3.5 ft below grade. Although other support sizes may be used with this size sign depending on the mounting height and selected wind speed, the W6×9 is considered more critical than the larger support sizes. It is the lightest and weakest of the “W” sections used for large guide signs, thereby making it more likely to fail in bending. Further, the narrow flange width provides less soil bearing area, thereby making it more prone to displacement through the soil. If this system is successfully tested, the results can be used to establish acceptance of other foundation post sizes.

Because the direct embedded system uses steel supports and is intended to be used for the relocation of existing signs, the recommended sign support design incorporates standard TxDOT slip base, fuse plate, and sign substrate connection details [ref. SMD (2-1) – 08 and SMD (2-2) – 08]. Connection of the extruded aluminum sign panel to the steel support posts involves inserting the square head of a bolt into a channel fabricated into the back side of an extruded aluminum panel. A cast clamp is inserted onto the bolt and secured with a nut. The clamp is positioned to extend over the flange of the steel support post. When the connection bolt is tightened, the extruded aluminum sign panel is clamped to the steel sign post.

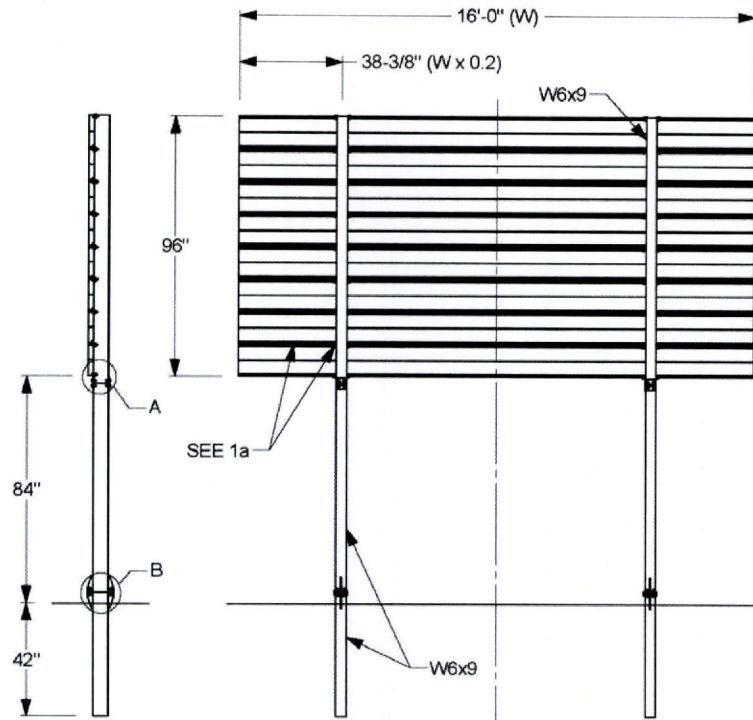

Figure 5.2. Overall Details of the Direct Embedded Steel Support Temporary Guide Sign System.

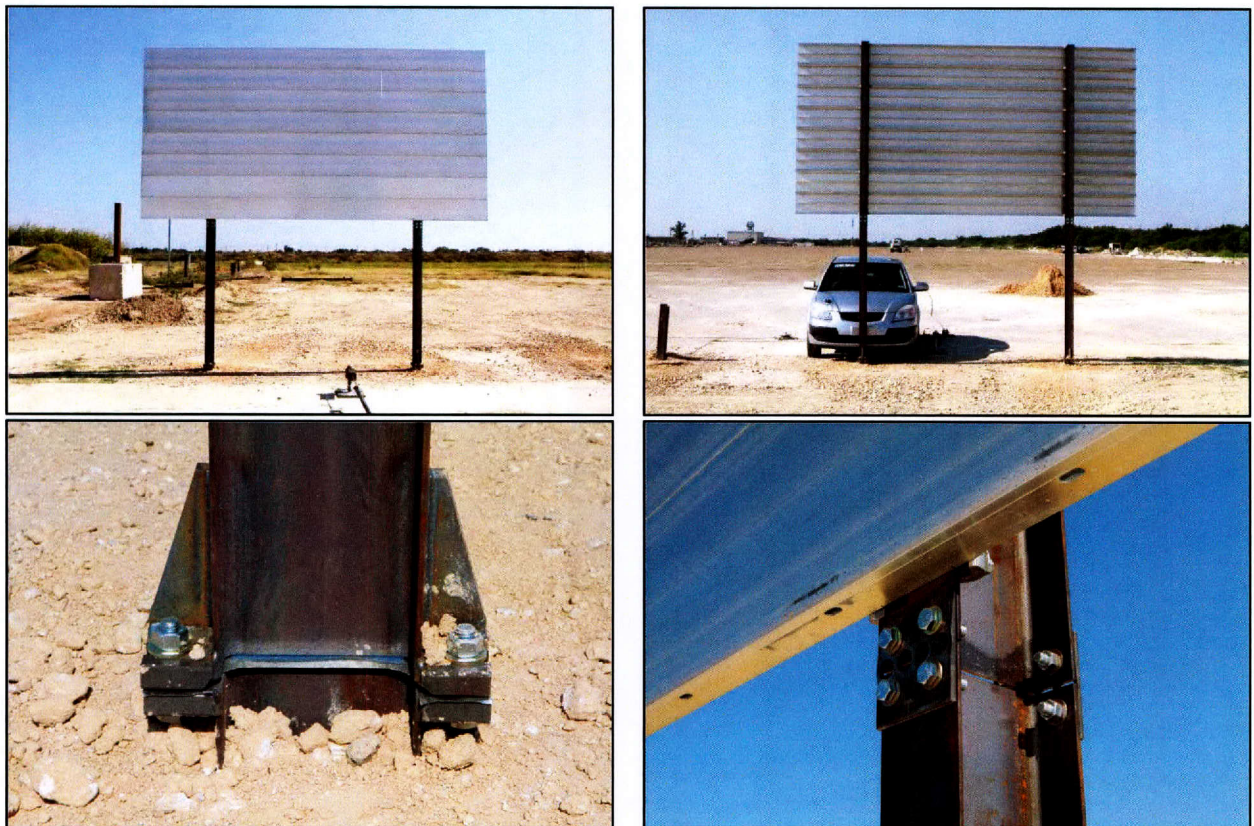

Figure 5.3. Direct Embedded Steel Support Temporary Guide Sign System.

5.4 MASH TEST 3-60 ON THE DIRECT EMBEDDED STEEL SUPPORT TEMPORARY GUIDE SIGN SYSTEM (TEST NO. 467823-4)

MASH recommends a matrix of three tests to validate the crashworthiness of a new sign support system. This includes two small car tests (low speed and high speed) and one high-speed pickup truck test. Only the low-speed small car test (*MASH* Test 3-60) was considered necessary to verify the impact performance of the direct embedded steel post foundation system for large temporary guide signs. The intent of the testing was not to evaluate the slip base design but to verify that the slip base will properly activate without excessive movement when attached to a direct embedded steel foundation post without a concrete footing.

Test 3-60 is considered to be the critical test for activation of the slip base system. Tests 3-61 and 3-62 are not considered necessary because they have been previously performed on steel support systems with standard concrete foundations, and the added inertial resistance of the soil at higher speeds makes activation of the slip base assured if it works at lower speed. Further, the slip base used in TxDOT's large guide sign systems is a proven design that has been successfully crash tested at higher speeds. The most recent testing of the large guide sign slip base system was performed under TxDOT Research Project 0-6363 (6).

5.4.1 Test Designation and Actual Impact Conditions

MASH Test 3-60 involves an 1100C vehicle weighing 2420 lb \pm 55 lb impacting the sign support at an impact speed of 19 mi/h \pm 2.5 mi/h and a critical impact angle of 0 degrees \pm 1.5 degrees. The target impact point was centerline of the vehicle aligned with centerline of the right support. The 2007 Kia Rio used for the test had a test inertial weight of 2425 lb and the actual impact speed and angle were 19.5 mi/h and 0 degrees, respectively. The actual impact point was centerline of the vehicle aligned with centerline of the support on the right side.

5.4.2 Test Vehicle

Figure 5.4 shows the 2007 Kia Rio used for the crash test. Test inertia weight of the vehicle was 2425 lb, and its gross static weight was 2608 lb. The height to the lower edge of the vehicle bumper was 7.12 inches, and the height to the upper edge of the bumper was 21.0 inches. Table H1 in Appendix H gives additional dimensions and information on the vehicle. The vehicle was directed into the installation using the cable reverse tow and guidance system and was released to be free-wheeling and unrestrained just prior to impact.

5.3.3 Weather and Soil Conditions

The test was performed on the morning of July 2, 2013. Weather conditions at the time of testing were as follows: wind speed: 6 mi/h; wind direction: 360 degrees with respect to the vehicle (vehicle was traveling in a northerly direction); temperature: 85°F, relative humidity: 47 percent.



Figure 5.4. Vehicle before Test No. 467823-4.

The test installation was installed in standard soil meeting AASHTO standard specifications for “Materials for Aggregate and Sol Aggregate Subbase, Base and Surface Courses,” designated M147-65(2004), grading B. In accordance with Appendix B of *MASH*, soil strength was measured the day of the crash test. The minimum post load required for deflections at 5 inches, 10 inches, and 15 inches, measured at a height of 25 inches, is 3940 lb, 5500 lb, and 6540 lb, respectively (90 percent of static load for the initial standard installation). On the day of the test, July 2, 2013, load on the post at deflections of 5 inches, 10 inches, and 15 inches was 14,040 lbf, 15,404 lbf, and 15,353 lbf, respectively. The strength of the backfill material met minimum requirements.

5.3.4 Test Description

The 2007 Kia Rio, traveling at an impact speed of 19.5 mi/h, impacted the right support at an impact angle of 0 degrees. At approximately 0.038 s, the right support leg began to slip away at the base as designed. At 0.384, the left support leg began to twist counterclockwise, and at 0.452 s, the front fuse plate on the right support leg fractured. The right support hinged and rotated about the back fuse plate below the sign panel. As the vehicle traveled forward, the steel support rode up the front of the vehicle and the slip base caught on the hood. The right support leg began pulling the hood upward at 0.547 s, and the lower right side of the sign panel contacted the hood of the vehicle at 0.669 s. As the vehicle exited the view of the high-speed cameras at 1.772 s, the sign panel and left support leg were continuing to rotate counterclockwise due to the momentum of the sign panel. Brakes on the vehicle were applied at 1.8 s after impact, and the vehicle came to rest 50 ft behind the impact location. Figures H1 and H2 in Appendix H show sequential photographs of the test period.

5.3.5 Damage to Test Installation

Figure 5.5 shows damage to the steel post sign support after the test. The lower section of the right support slipped away from the ground stub, and hinged at the upper connection. The lower section of the support on the left remained attached to the ground stub and the support was twisted 80 degrees. One bolt in the upper hinge sheared, but remained attached to the sign panel and lower section of the support.

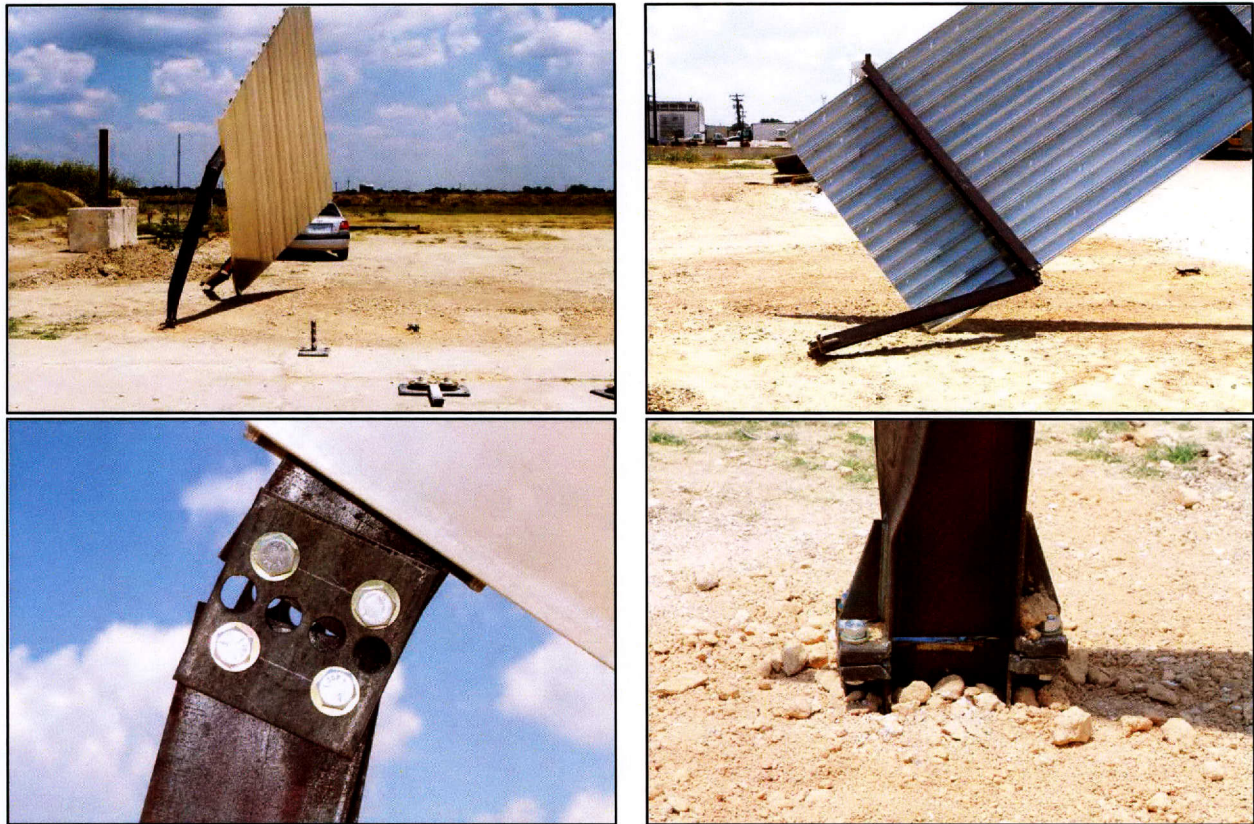

Figure 5.5. Direct Embedded Steel Support Temporary Guide Sign System after Test No. 467823-4.

5.3.6 Vehicle Damage

Figure 5.6 shows the damage sustained by the vehicle during the test, which included the front bumper, hood, windshield, left A-post, and left front fender. The hood was deformed and was pushed back into the windshield. The contact with the hood shattered the lower left corner of the windshield over an area measuring 10 inches \times 16 inches. There was no measurable crush to the exterior of the vehicle and no deformation or intrusion into the occupant compartment. Exterior crush and occupant compartment measurements can be found in Tables H2 and H3 of Appendix H.

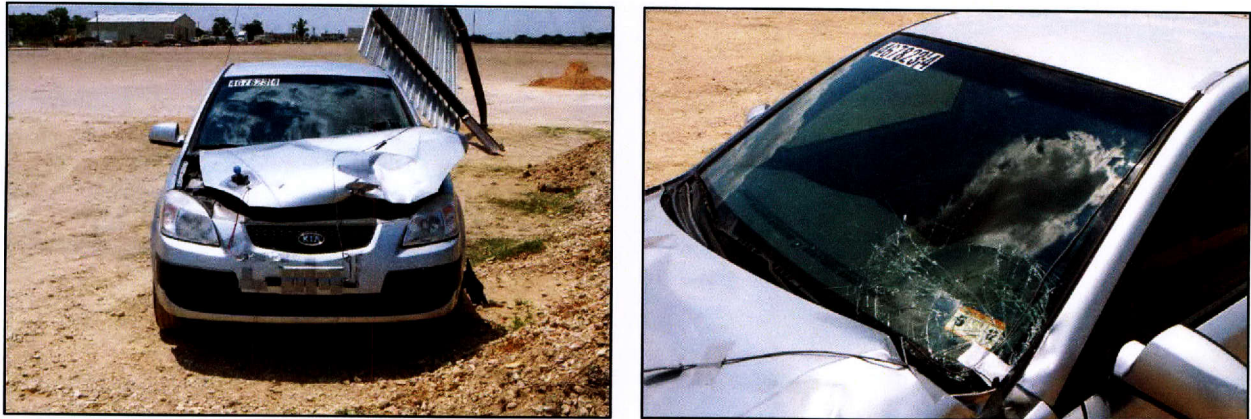

Figure 5.6. Vehicle after Test No. 467823-1.

5.3.7 Occupant Risk Factors

Data from the accelerometer, located at the vehicle center of gravity, were digitized for evaluation of occupant risk. In the longitudinal direction, the occupant impact velocity was 6.2 ft/s at 0.628 s, the highest 0.010-s occupant ridedown acceleration was 0.6 Gs from 0.637 to 0.647 s, and the maximum 0.050-s average acceleration was -0.8 Gs between 0.000 and 0.050 s. In the lateral direction, the occupant impact velocity was 1.3 ft/s at 0.628 s, the highest 0.010-s occupant ridedown acceleration was 0.6 Gs from 0.668 to 0.678 s, and the maximum 0.050-s average was -0.4 Gs between 0.637 and 0.687 s. Theoretical Head Impact Velocity was 7.0 km/h or 2.0 m/s at 0.629 s; Post-Impact Head Decelerations was 0.8 Gs between 0.637 and 0.647 s; and Acceleration Severity Index was 0.06 between 0.000 and 0.050 s. Figure 5.7 summarizes these data and other pertinent information from the test. Vehicle angular displacements and accelerations versus time traces are presented in Appendix H, Figures H3 through H9.

5.3.8 Assessment of Test Results

An assessment of the test based on the applicable *MASH* safety evaluation criteria is provided below.

5.3.8.1 Structural Adequacy

B. The test article should readily activate in a predictable manner by breaking away, fracturing, or yielding.

Results: The direct embedded steel post support system for temporary guide signs activated readily by releasing at the slip base, fracturing the front fuse plate, and rotating about the back fuse plate as designed. (PASS)

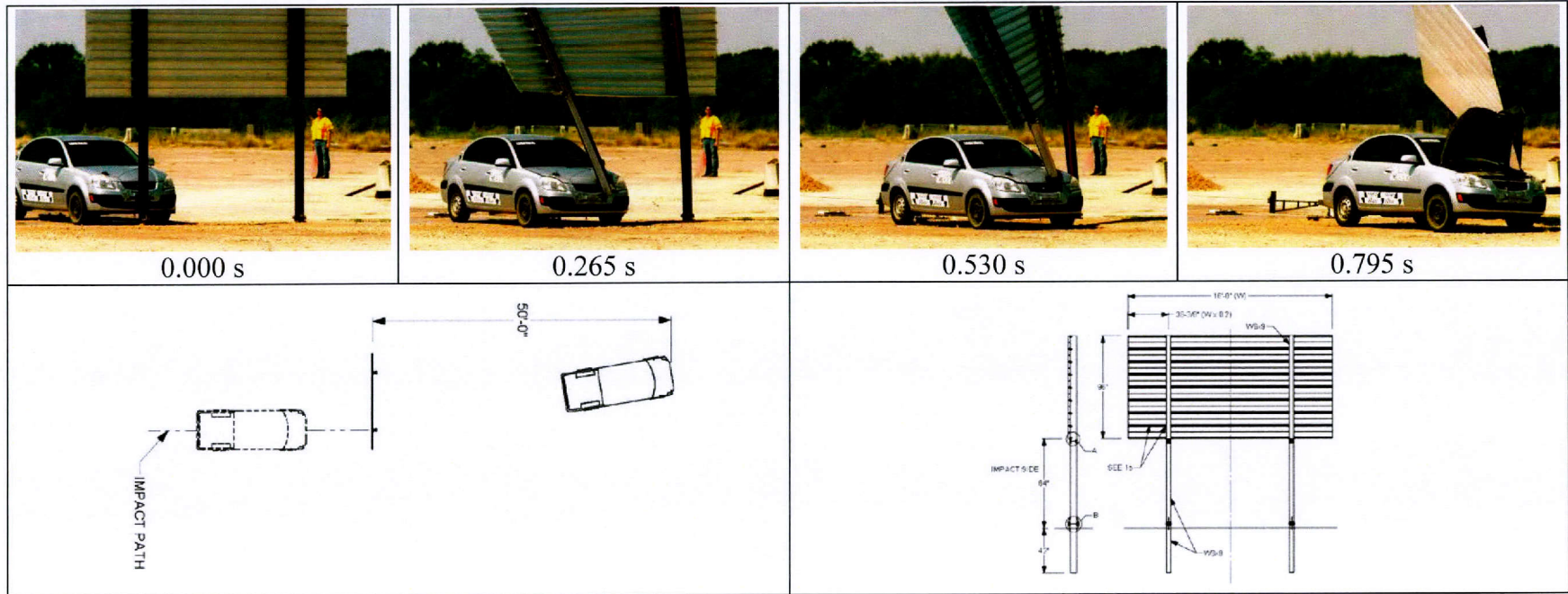

General Information

Test Agency Texas A&M Transportation Institute (TTI)
 Test Standard Test No. MASH Test 3-60
 TTI Test No. 467823-4
 Test Date 2013-07-02

Test Article

Type Sign Support
 Name TxDOT Direct Embedded Steel Support Temporary Guide Sign System
 Installation Mounting Height 7 ft
 Material or Key Elements 8-ft x 16-ft extruded aluminum sign panel on by two W6x9 steel posts with fuse plates and slip base connections

Soil Type

Standard Soil of Crushed Limestone

Test Vehicle

Type/Designation 1100C
 Make and Model 2007 Kia Rio
 Curb 2348 lb
 Test Inertial 2425 lb
 Dummy 183 lb
 Gross Static 2608 lb

Impact Conditions

Speed 19.5 mi/h
 Angle 0 degrees
 Location/Orientation Right support

Exit Conditions

Speed Not attainable
 Angle 0 degrees

Occupant Risk Values

Impact Velocity
 Longitudinal 6.2 ft/s
 Lateral 1.3 ft/s
 Ridedown Accelerations
 Longitudinal 0.6 G
 Lateral 0.6 G
 THIV 2.0 m/s
 PHD 0.8 G
 ASI 0.04
 Max. 0.050-s Average
 Longitudinal -0.8 G
 Lateral -0.4 G
 Vertical -0.4 G

Post-Impact Trajectory

Stopping Distance 50 ft dwnstrm

Vehicle Stability

Maximum Yaw Angle 10 degrees
 Maximum Pitch Angle 1 degrees
 Maximum Roll Angle 4 degrees
 Vehicle Snagging NA
 Vehicle Pocketing NA

Test Article Debris Pattern

Longitudinal 20 ft
 Lateral 10 ft

Vehicle Damage

VDS 12FC1
 CDC 12FCEN2
 Max. Exterior Deformation Hood damage only
 OCDI FS0000000
 Max. Occupant Compartment Deformation None

Figure 5.7. Summary of Results for MASH Test 3-60 on the Direct Embedded Wood Support Temporary Guide Sign System.

5.3.8.2 *Occupant Risk*

D. *Detached elements, fragments, or other debris from the test article should not penetrate or show potential for penetrating the occupant compartment, or present an undue hazard to other traffic, pedestrians, or personnel in a work zone.*

Deformation of, or intrusions into, the occupant compartment should not exceed limits set forth in Section 5.3 and Appendix E of MASH. (roof ≤ 4.0 inches; windshield = ≤ 3.0 inches; side windows = no shattering by test article structural member; wheel/foot well/toe pan ≤ 9.0 inches; forward of A-pillar ≤ 12.0 inches; front side door area above seat ≤ 9.0 inches; front side door below seat ≤ 12.0 inches; floor pan/transmission tunnel area ≤ 12.0 inches).

Results: The right support detached from its base as designed but remained attached to the sign panel. It did not penetrate or show potential for penetrating the occupant compartment nor to present an undue hazard to others. (PASS)

There was not measured occupant compartment deformation. (PASS)

F. *The vehicle should remain upright during and after collision. The maximum roll and pitch angles are not to exceed 75 degrees.*

Results: The 1100C vehicle remained upright during and after the collision event. Maximum roll and pitch angles were 4 degrees and 1 degree, respectively. (PASS)

H. *Occupant impact velocities should satisfy the following:*

Longitudinal and Lateral Occupant Impact Velocity

<u>Preferred</u>	<u>Maximum</u>
10 ft/s	16.4 ft/s

Results: Longitudinal occupant impact velocity was 6.2 ft/s, and lateral occupant impact velocity was 1.3 ft/s. (PASS)

I. *Occupant ridedown accelerations should satisfy the following:*

Longitudinal and Lateral Occupant Ridedown Accelerations

<u>Preferred</u>	<u>Maximum</u>
15.0 Gs	20.49 Gs

Results: Maximum longitudinal ridedown acceleration was 0.6 G, and maximum lateral ridedown acceleration was 0.6 G. (PASS)

5.3.8.3 *Vehicle Trajectory*

N. *Vehicle trajectory behind the test article is acceptable.*

Result: The 1100C vehicle came to rest 50 ft behind the installation. (PASS)

CHAPTER 6. SUMMARY AND CONCLUSIONS

6.1 DIRECT EMBEDDED WOOD SUPPORT TEMPORARY GUIDE SIGN SYSTEM

A direct embedded wood support temporary guide sign system was developed and crash tested in accordance with *MASH* guidelines. In Test 3-60, the wood support posts fractured at the weakening holes as designed. Rotation of the sign panel caused it to pry away from the remaining support post and fall onto the vehicle. The windshield damage and roof deformation resulted from the falling sign were acceptable according to *MASH* evaluation criteria. The maximum occupant compartment deformation at the rear of the roof at the back window was 3.5 inches, which is less than the 4-inch allowable limit. Although the windshield was cracked, there were no holes or tears through the safety liner, and the deformation was below the 3-inch allowable threshold. All occupant risk criteria were within *MASH* requirements for breakaway support structures. As summarized in Table 6.1, the direct embedded wood support temporary guide sign system met all applicable *MASH* evaluation criteria for Test 3-60.

With the success of Test 3-60, the researchers performed Test 3-61. Upon impact, the wood supports fractured at ground line and below the sign panel as designed. However, the released support members rotated into the windshield of the test vehicle. As indicated in Table 6.2, the direct embedded wood support temporary guide sign system failed to meet *MASH* impact performance requirements for Test 3-61 due to windshield penetration resulting from secondary contact with the fractured wood supports.

TTI research engineers modified the design of the temporary large guide sign support system to address the identified problem. The solution incorporated a ¼-inch diameter restraining cable that acts as a hinge point for the fractured wood supports and permits the impacting vehicle to travel beneath the sign system without secondary windshield or roof contact.

Crash testing was performed to evaluate the impact performance of the modified design. The researchers concluded that the low-speed car test (Test 3-60) did not need to be rerun because the behavior observed in this test would not change by adding a hinge point for the fractured support post at the bottom of the sign. Therefore, the test matrix for the modified design consisted of two tests: Test 3-61 (high-speed small car test) and Test 3-62 (high-speed pickup truck test).

Test 3-61 was repeated on the modified direct embedded wood support temporary guide sign system. Upon impact, the wood supports fractured at ground line, at bumper height, and below the sign panel as designed. The fractured supports rotated upward about the restraining cables, and the test vehicle past underneath the sign installation without any secondary contact. The occupant impact velocity was 6.9 ft/s, which is below the preferred value in *MASH*. As summarized in Table 6.3, the modified direct embedded wood support temporary guide sign system with restraining cable met all applicable *MASH* evaluation criteria for Test 3-61.

With the success of Test 3-61, the researchers performed Test 3-62. As shown in Table 6.4, the modified direct embedded wood support temporary guide sign system with restraining

cable met all applicable *MASH* evaluation criteria for Test 3-62. Occupant impact velocity was 4.6 ft/sec, which is below the preferred value. The roof deformation resulting from secondary contact with pieces of wood projecting from the fractured supports was minor in nature and did not result in any occupant compartment deformation.

In conclusion, the modified direct embedded wood support temporary guide sign system met all required *MASH* testing criteria. Chapter 8 discusses implementation recommendations regarding the system.

6.2 DIRECT EMBEDDED STEEL SUPPORT TEMPORARY GUIDE SIGN SYSTEM

A direct embedded wood support temporary guide sign system was developed and crash tested in accordance with *MASH* guidelines. According to *MASH*, a matrix of 3 tests is recommended to validate the crashworthiness of a new sign support system. This includes two small car tests (low speed and high speed) and one high-speed pickup truck test. The slip base used in TxDOT's large guide sign systems is a proven design that has been successfully crash tested. The most recent testing of the large guide sign slip base system was performed under TxDOT Research Project 0-6363.

Therefore, the intent of the testing was not to evaluate the slip base design but to verify that the slip base will properly activate without excessive movement when attached to a direct embedded steel foundation post without a concrete footing. Consequently, the researchers concluded that only the small car low-speed test (Test 3-60) was necessary to evaluate the impact performance of the direct embedded steel foundation post system. This is considered to be the critical test for activation of the slip base system. The added inertial resistance of the soil at higher speeds makes activation of the slip base assured if it works at lower speed.

During the test, the slip base activated as designed and the released steel support hinged and rotated about the fuse plates below the sign panel. As the vehicle traveled forward, the steel support rode up the front of the vehicle and the slip base caught on the hood. The hood was deformed and was pushed back into the windshield. This contact caused the lower left corner of the windshield to shatter. However, there were no holes or tears through the safety liner, and the deformation was below the 3-inch allowable threshold. The occupant impact velocity was below the preferred threshold recommended in *MASH*. As summarized in Table 6.5, the direct embedded steel support temporary guide sign system met all applicable *MASH* evaluation criteria for Test 3-60.

Table 6.1. Performance Evaluation Summary for MASH Test 3-60 on the Direct Embedded Wood Support Temporary Guide Sign System.

Test Agency: Texas A&M Transportation Institute

Test No.: 467823-1

Test Date: 2013-05-24

MASH Test 3-60 Evaluation Criteria	Test Results	Assessment
<p>Structural Adequacy</p> <p>C. <i>Acceptable test article performance may be by redirection, controlled penetration, or controlled stopping of the vehicle.</i></p>	The direct embedded wood post support system for temporary guide signs performed acceptably by fracturing at the upper and lower holes.	Pass
<p>Occupant Risk</p> <p>D. <i>Detached elements, fragments, or other debris from the test article should not penetrate or show potential for penetrating the occupant compartment, or present an undue hazard to other traffic, pedestrians, or personnel in a work zone.</i></p>	The detached sections of the supports did not penetrate or show potential for penetrating the occupant compartment, nor to present an undue hazard to others.	Pass
<p><i>Deformations of, or intrusions into, the occupant compartment should not exceed limits set forth in Section 5.3 and Appendix E of MASH.</i></p>	Maximum occupant compartment deformation was 3.5 inches in the right rear passenger roof area.	Pass
<p>F. <i>The vehicle should remain upright during and after collision. The maximum roll and pitch angles are not to exceed 75 degrees.</i></p>	The 1100C vehicle remained upright during and after the collision event. Maximum roll and pitch angles were 20 degrees and 71 degrees, respectively.	Pass
<p>H. <i>Longitudinal and lateral occupant impact velocities should fall below the preferred value of 10 ft/s, or at least below the maximum allowable value of 16.4 ft/s.</i></p>	Longitudinal occupant impact velocity was 11.2 ft/s, and lateral occupant impact velocity was 2.0 ft/s.	Pass
<p>I. <i>Longitudinal and lateral occupant ridedown accelerations should fall below the preferred value of 15.0 Gs, or at least below the maximum allowable value of 20.49 Gs.</i></p>	Maximum longitudinal ridedown acceleration was 0.9 G, and maximum lateral ridedown acceleration was 1.0 G.	Pass
<p>Vehicle Trajectory</p> <p>N. <i>Vehicle trajectory behind the test article is acceptable.</i></p>	The 1100C vehicle came to rest 45 ft behind the installation.	Pass

Table 6.2. Performance Evaluation Summary for MASH Test 3-61 on the Direct Embedded Wood Support Temporary Guide Sign System.

Test Agency: Texas A&M Transportation Institute

Test No.: 467823-2

Test Date: 2013-05-24

MASH Test 3-61 Evaluation Criteria	Test Results	Assessment
Structural Adequacy C. <i>Acceptable test article performance may be by redirection, controlled penetration, or controlled stopping of the vehicle.</i>	The direct embedded wood post support system for temporary guide signs performed acceptably by fracturing at the upper and lower holes.	Pass
Occupant Risk D. <i>Detached elements, fragments, or other debris from the test article should not penetrate or show potential for penetrating the occupant compartment, or present an undue hazard to other traffic, pedestrians, or personnel in a work zone.</i>	The fractured sections of posts rotated and penetrated the windshield of the vehicle.	Fail
<i>Deformations of, or intrusions into, the occupant compartment should not exceed limits set forth in Section 5.3 and Appendix E of MASH.</i>	The fractured sections of posts rotated and penetrated the windshield of the vehicle.	Fail
F. <i>The vehicle should remain upright during and after collision. The maximum roll and pitch angles are not to exceed 75 degrees.</i>	The 1100C vehicle remained upright during and after the collision event. Maximum roll and pitch angles were 6 degrees and 3 degrees, respectively.	Pass
H. <i>Longitudinal and lateral occupant impact velocities should fall below the preferred value of 10 ft/s, or at least below the maximum allowable value of 16.4 ft/s.</i>	Longitudinal occupant impact velocity was 8.5 ft/s, and lateral occupant impact velocity was 0.3 ft/s.	Pass
I. <i>Longitudinal and lateral occupant ridedown accelerations should fall below the preferred value of 15.0 Gs, or at least below the maximum allowable value of 20.49 Gs.</i>	Maximum longitudinal ridedown acceleration was 2.0 G, and maximum lateral ridedown acceleration was 1.0 G.	Pass
Vehicle Trajectory N. <i>Vehicle trajectory behind the test article is acceptable.</i>	The 1100C vehicle came to rest 196 ft behind the installation.	Pass

Table 6.3. Performance Evaluation Summary for MASH Test 3-61 on the Modified Direct Embedded Wood Support Temporary Guide Sign System.

Test Agency: Texas A&M Transportation Institute

Test No.: 467823-2b

Test Date: 2013-06-13

MASH Test 3-61 Evaluation Criteria	Test Results	Assessment
<p>Structural Adequacy C. <i>Acceptable test article performance may be by redirection, controlled penetration, or controlled stopping of the vehicle.</i></p>	<p>The modified direct embedded wood post support system for temporary guide signs performed acceptably by fracturing upon impact.</p>	<p>Pass</p>
<p>Occupant Risk D. <i>Detached elements, fragments, or other debris from the test article should not penetrate or show potential for penetrating the occupant compartment, or present an undue hazard to other traffic, pedestrians, or personnel in a work zone.</i></p>	<p>The fractured sections of supports remained attached via the cables and did not penetrate or show potential for penetrating the occupant compartment, or to present hazard to others in the area.</p>	<p>Pass</p>
<p><i>Deformations of, or intrusions into, the occupant compartment should not exceed limits set forth in Section 5.3 and Appendix E of MASH.</i></p>	<p>No occupant compartment penetration or deformation occurred.</p>	<p>Pass</p>
<p>F. <i>The vehicle should remain upright during and after collision. The maximum roll and pitch angles are not to exceed 75 degrees.</i></p>	<p>The 1100C vehicle remained upright during and after the collision event. Maximum roll and pitch angles were 1.4 degrees and 15 degrees, respectively.</p>	<p>Pass</p>
<p>H. <i>Longitudinal and lateral occupant impact velocities should fall below the preferred value of 10 ft/s, or at least below the maximum allowable value of 16.4 ft/s.</i></p>	<p>Longitudinal occupant impact velocity was 6.9 ft/s, and lateral occupant impact velocity was 1.0 ft/s.</p>	<p>Pass</p>
<p>I. <i>Longitudinal and lateral occupant ridedown accelerations should fall below the preferred value of 15.0 Gs, or at least below the maximum allowable value of 20.49 Gs.</i></p>	<p>Maximum longitudinal ridedown acceleration was 1.4 G, and maximum lateral ridedown acceleration was 0.8 G.</p>	<p>Pass</p>
<p>Vehicle Trajectory N. <i>Vehicle trajectory behind the test article is acceptable.</i></p>	<p>The 1100C vehicle came to rest 212 ft behind the installation.</p>	<p>Pass</p>

Table 6.4. Performance Evaluation Summary for MASH Test 3-62 on the Modified Direct Embedded Wood Support Temporary Guide Sign System.

Test Agency: Texas A&M Transportation Institute

Test No.: 467823-3

Test Date: 2013-06-13

MASH Test 3-62 Evaluation Criteria	Test Results	Assessment
<p>Structural Adequacy C. <i>Acceptable test article performance may be by redirection, controlled penetration, or controlled stopping of the vehicle.</i></p>	<p>The modified direct embedded wood post support system for temporary guide signs performed acceptably by fracturing upon impact.</p>	<p>Pass</p>
<p>Occupant Risk D. <i>Detached elements, fragments, or other debris from the test article should not penetrate or show potential for penetrating the occupant compartment, or present an undue hazard to other traffic, pedestrians, or personnel in a work zone.</i></p>	<p>The fractured sections of supports remained attached via the cables and did not penetrate or show potential for penetrating the occupant compartment, or to present hazard to others in the area.</p>	<p>Pass</p>
<p><i>Deformations of, or intrusions into, the occupant compartment should not exceed limits set forth in Section 5.3 and Appendix E of MASH.</i></p>	<p>No occupant compartment penetration or deformation occurred.</p>	<p>Pass</p>
<p>F. <i>The vehicle should remain upright during and after collision. The maximum roll and pitch angles are not to exceed 75 degrees.</i></p>	<p>The 2270P vehicle remained upright during and after the collision event. Maximum roll and pitch angles were 3 degrees and 1 degree, respectively.</p>	<p>Pass</p>
<p>H. <i>Longitudinal and lateral occupant impact velocities should fall below the preferred value of 10 ft/s, or at least below the maximum allowable value of 16.4 ft/s.</i></p>	<p>Longitudinal occupant impact velocity was 4.6 ft/s, and lateral occupant impact velocity was 1.3 ft/s.</p>	<p>Pass</p>
<p>I. <i>Longitudinal and lateral occupant ridedown accelerations should fall below the preferred value of 15.0 Gs, or at least below the maximum allowable value of 20.49 Gs.</i></p>	<p>Maximum longitudinal ridedown acceleration was 1.5 G, and maximum lateral ridedown acceleration was 1.0 G.</p>	<p>Pass</p>
<p>Vehicle Trajectory N. <i>Vehicle trajectory behind the test article is acceptable.</i></p>	<p>The 2270P vehicle came to rest 224 ft behind the installation.</p>	<p>Pass</p>

Table 6.5. Performance Evaluation Summary for MASH Test 3-60 on the Direct Embedded Steel Support Temporary Guide Sign System.

Test Agency: Texas A&M Transportation Institute

Test No.: 467823-4

Test Date: 2013-07-02

MASH Test 3-60 Evaluation Criteria	Test Results	Assessment
<p>Structural Adequacy</p> <p>C. <i>Acceptable test article performance may be by redirection, controlled penetration, or controlled stopping of the vehicle.</i></p>	The direct embedded steel post support system for temporary guide signs performed acceptably by fracturing at the upper and lower connections.	Pass
<p>Occupant Risk</p> <p>D. <i>Detached elements, fragments, or other debris from the test article should not penetrate or show potential for penetrating the occupant compartment, or present an undue hazard to other traffic, pedestrians, or personnel in a work zone.</i></p>	The right support detached from the base, but remained attached to the sign panel, and did not penetrate or show potential for penetrating the occupant compartment, nor to present an undue hazard to others.	Pass
<p><i>Deformations of, or intrusions into, the occupant compartment should not exceed limits set forth in Section 5.3 and Appendix E of MASH.</i></p>	No occupant compartment deformation occurred.	Pass
<p>F. <i>The vehicle should remain upright during and after collision. The maximum roll and pitch angles are not to exceed 75 degrees.</i></p>	The 1100C vehicle remained upright during and after the collision event. Maximum roll and pitch angles were 4 degrees and 1 degrees, respectively.	Pass
<p>H. <i>Longitudinal and lateral occupant impact velocities should fall below the preferred value of 10 ft/s, or at least below the maximum allowable value of 16.4 ft/s.</i></p>	Longitudinal occupant impact velocity was 6.2 ft/s, and lateral occupant impact velocity was 1.3 ft/s.	Pass
<p>I. <i>Longitudinal and lateral occupant ridedown accelerations should fall below the preferred value of 15.0 Gs, or at least below the maximum allowable value of 20.49 Gs.</i></p>	Maximum longitudinal ridedown acceleration was 0.6 G, and maximum lateral ridedown acceleration was 0.6 G.	Pass
<p>Vehicle Trajectory</p> <p>N. <i>Vehicle trajectory behind the test article is acceptable.</i></p>	The 1100C vehicle came to rest 50 ft behind the installation.	Pass

CHAPTER 7. IMPLEMENTATION STATEMENT

7.1 DIRECT EMBEDDED WOOD SUPPORT TEMPORARY GUIDE SIGN SYSTEM

A temporary support system for large guide signs was developed and successfully crash tested in accordance with *MASH* guidelines. This system provides a cost-effective option for highway construction projects in which there exists a need to temporarily relocate large guide signs on the roadside or install new guide signs for temporary use. The wooden support posts are directly embedded in the ground, thus eliminating the need for reinforced concrete foundations that are costly and time consuming to both install and remove at the completion of the construction project.

The direct embedded wood support temporary guide sign system met all *MASH* evaluation criteria and is considered suitable for implementation. Appendix D shows detailed drawings of the tested system. The results of the crash tests reported herein can be used to establish acceptance of other less critical design configurations for other sizes of temporary guide signs. For example, the testing with the stronger Grade 1 wood posts provides the basis for acceptance of weaker Grade 2 material that may have better availability at reduced cost. Similarly, successfully impacting two support posts simultaneously allows for acceptance of configurations with larger post spacing in which only one 6-inch × 8-inch post can be impacted. Additionally, testing the more critical extruded aluminum sign substrate provides the basis for use of plywood substrates with the temporary support system.

Engineering calculations can be used as the basis for acceptance for other support post types as well. The full-scale crash testing establishes an upper limit on post strength. Therefore, various combinations of 4-inch × 6-inch posts with appropriately sized weakening holes would be acceptable provided their combined flexural strength (as defined by section modulus) is less than or equal to the combined strength of the dual 6-inch × 8-inch posts with 4-inch weakening holes. More detailed guidelines for the use of the direct embedded wood support temporary guide sign system will be developed during the second year of this research project.

7.2 DIRECT EMBEDDED STEEL SUPPORT TEMPORARY GUIDE SIGN SYSTEM

A direct embedded steel foundation post system for use with temporary guide signs with steel support posts was developed and successfully crash tested in accordance with *MASH* guidelines. The direct embedded steel post foundation system is suitable for use in both the relocation of existing steel sign support systems and new guide signs that might be required as part of a highway construction project. Use of the existing sign substrate and steel sign support members on a temporary direct embedment steel foundation post will reduce the relocation cost. The direct embedment installation method allows for currently installed large guide signs to be relocated temporarily on driven steel foundation posts without installing more expensive and hard to remove concrete foundations. This approach also eliminates required cure time for the concrete foundation, thereby permitting the foundation and sign structure to be installed during the same site visit.

The direct embedded steel support foundation system for temporary guide signs met all *MASH* evaluation criteria and is considered suitable for implementation. The results of the crash test validate the foundation design procedures and provide the basis for acceptance of other steel foundation posts with their respective embedment depths as shown in Table 7.1. The size of the foundation post should be selected to match the support posts used in the sign support system. Implementation of the new direct embedded steel foundation post systems can be accomplished through the issuance of new or revised standard detail sheet by the Traffic Operation Division as appropriate. Detailed drawings of the tested system are shown in Appendix G.

Table 7.1. Recommended Embedment Depths for Selected Steel Supports.

Post Size	Embedment Depth (ft)			
	Hw (ft)		Average	Recommended
	11	14		
W6x9	3.4	3.4	3.4	3.5
W6x12	3.9	3.8	3.8	4.0
W6x15	4.0	3.9	3.9	4.0
W8x18	5.0	4.9	5.0	5.0
W8x21	5.4	5.3	5.4	5.5
W10x22	5.9	5.8	5.9	6.0
W10x26	6.5	6.3	6.4	6.5
W12x26	6.8	6.6	6.7	6.5
S3x5.7	2.3	2.3	2.3	2.5

REFERENCES

1. AASHTO, *Standard Specifications for Structural Supports for Highway Signs, Luminaires, and Traffic Signals*, Fifth Edition, American Association of State Highway and Transportation Officials, Washington, DC, 2009.
2. AASHTO, *Manual for Assessing Safety Hardware*, American Association of State Highway and Transportation Officials, Washington, DC, 2009.
3. "Testing of Small and Large Sign Supports," FHWA Project DTFH61-89-C-00100.
4. H. E. Ross, Jr., D. L. Sicking, R. A. Zimmer, and J. D. Michie. *Recommended Procedures for the Safety Performance Evaluation of Highway Features*, National Cooperative Highway Research Program Report 350, Transportation Research Board, National Research Council, Washington, DC, 1993.
5. Federal Highway Administration, *Memorandum HNG-14/SS-36*, U.S. Department of Transportation, Washington, DC, September 3, 1993.
6. C. Silvestri Dobrovolny, D. R. Arrington, R. P. Bligh, and W. L. Menges. *Development Guidance for Sign Design Standards*, Report No. 0-6363-1, Texas A&M Transportation Institute, College Station, TX, February 2012.

APPENDIX A. DETAILS OF THE DIRECT EMBEDDED WOOD
SUPPORT TEMPORARY GUIDE SIGN SYSTEM

APPENDIX A. SUPPORT FOR DIRECT EMBEDDED WOOD SUPPORT TEMPORARY GUIDE SIGN SYSTEM

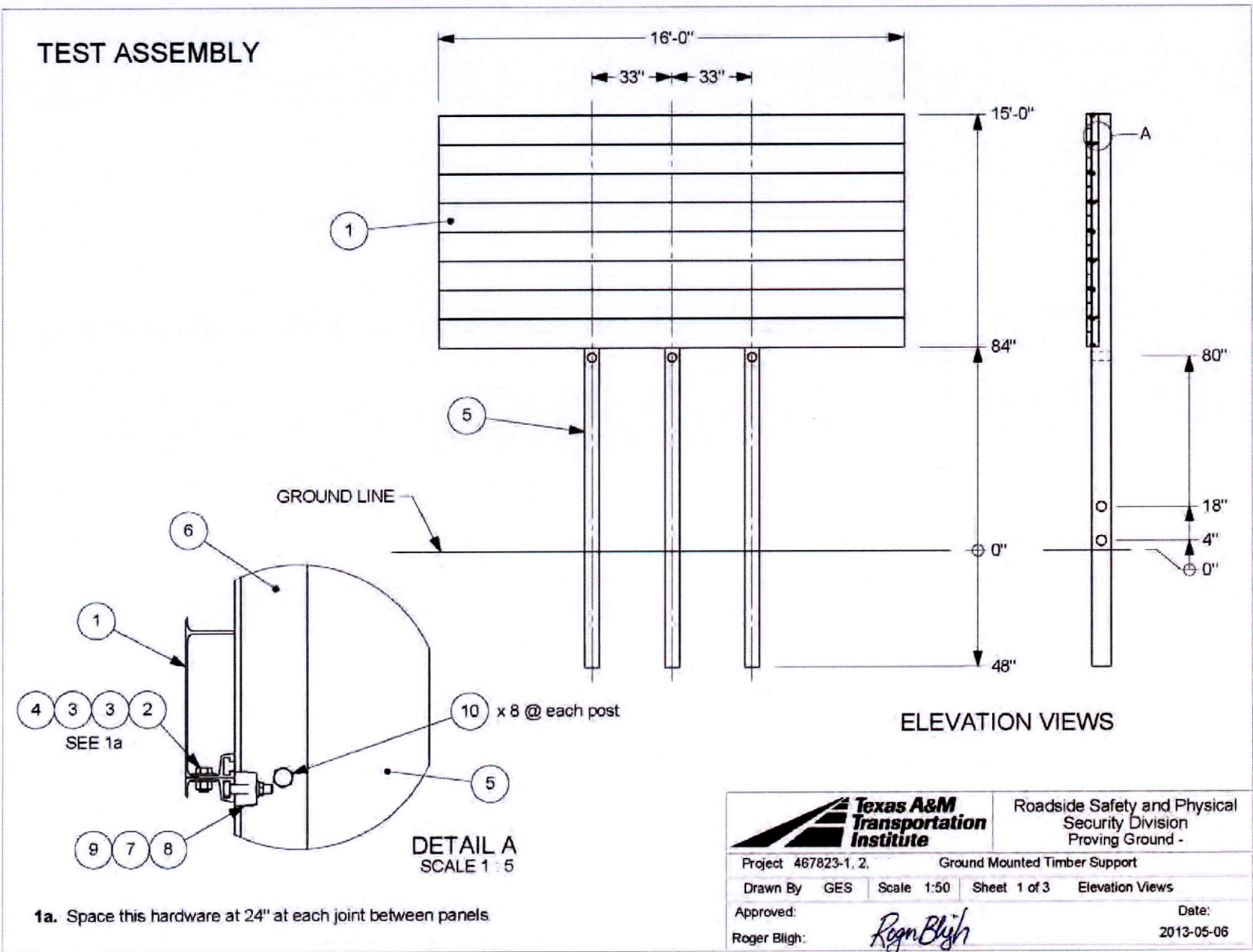

INSTALLATION PARTS			
#	PART NAME	DETAILS	QTY.
1	Aluminum Sign Panel, 12" x 16"	see TxDOT Drawing SMD (2-1) -08	8
2	Bolt, 3/8 x 3/4 hex	grade 2	56
3	Washer, 3/8 flat		112
4	Nut, 3/8 hex		56
5	Timber Post	sheet 3	3
6	Angle Stiffener	sheet 3	6
7	Bolt, 3/8 x 1-3/4 square head	see TxDOT Drawing SMD (2-1) -08	54
8	Sign Clip	see TxDOT Drawing SMD (2-1) -08	54
9	Nut, 3/8 flange		54
10	1/2 x 3 Lag Bolt	A307	24

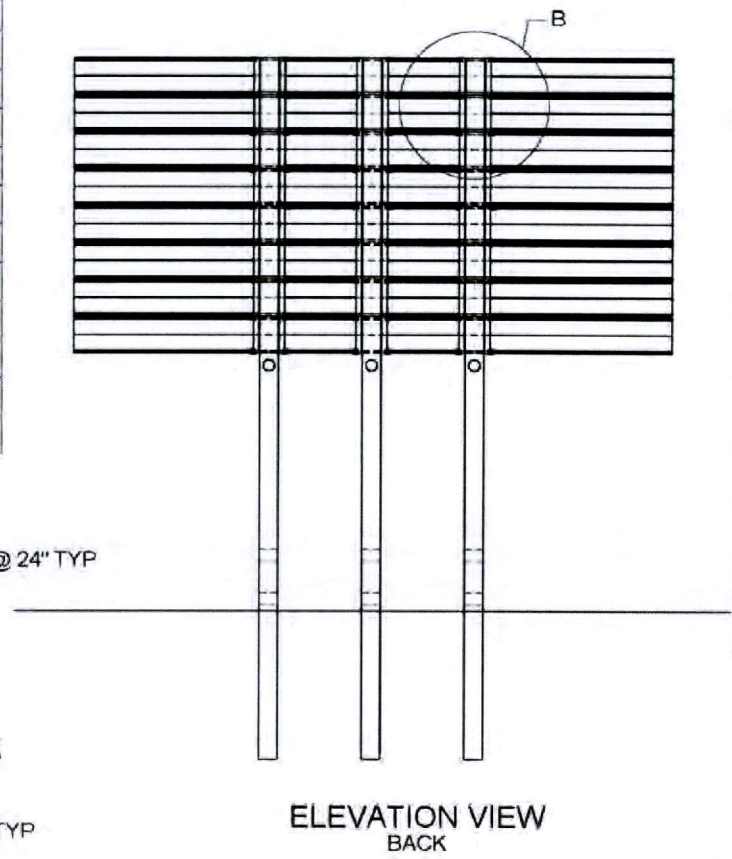
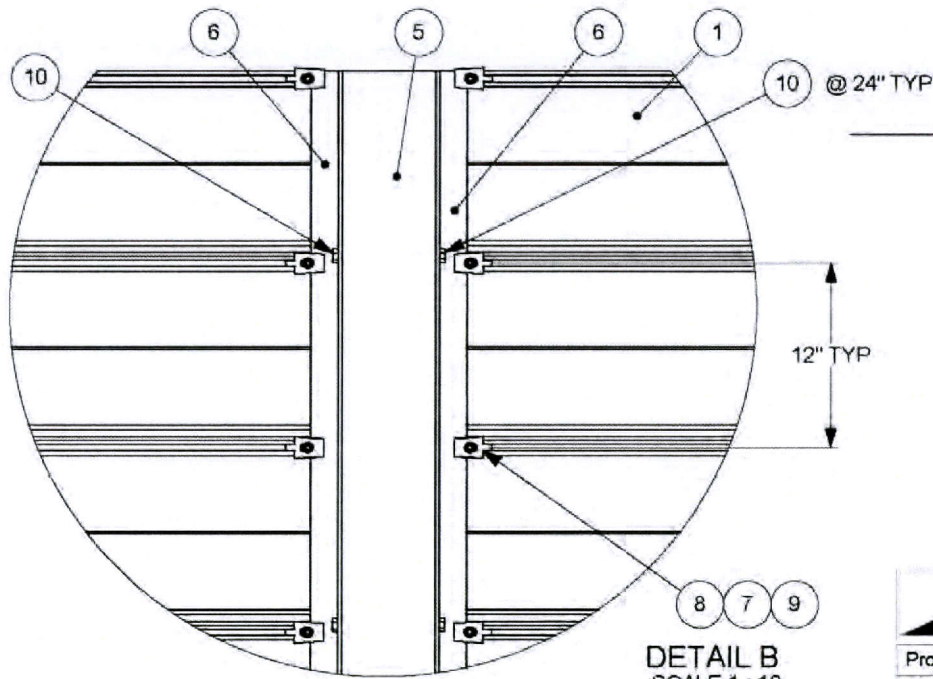

	Roadside Safety and Physical Security Division - Proving Ground		
	Project 467823-1, 2,	Ground Mounted Timber Support	2013-05-06
Drawn By GES	Scale 1:50	Sheet 2 of 3	Back View

T:\2012-2013\467823-TxDOT Temp Sign Support\Ground Mounted Timber Support\Drafting\2013-05-06\467823-1 Drawing

5 Timber Post

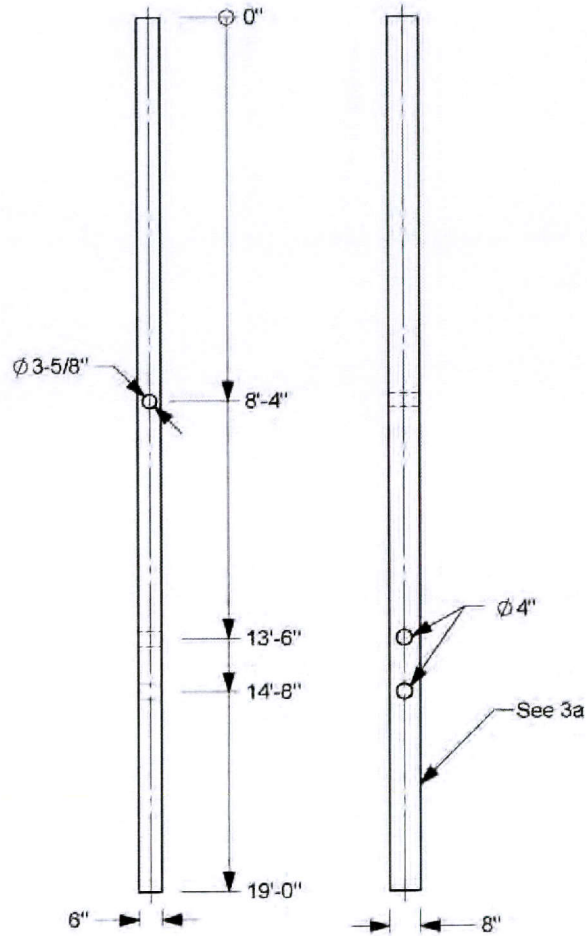

3a. Timber Post is rough-cut treated #1 yellow pine.

6 Angle Stiffener

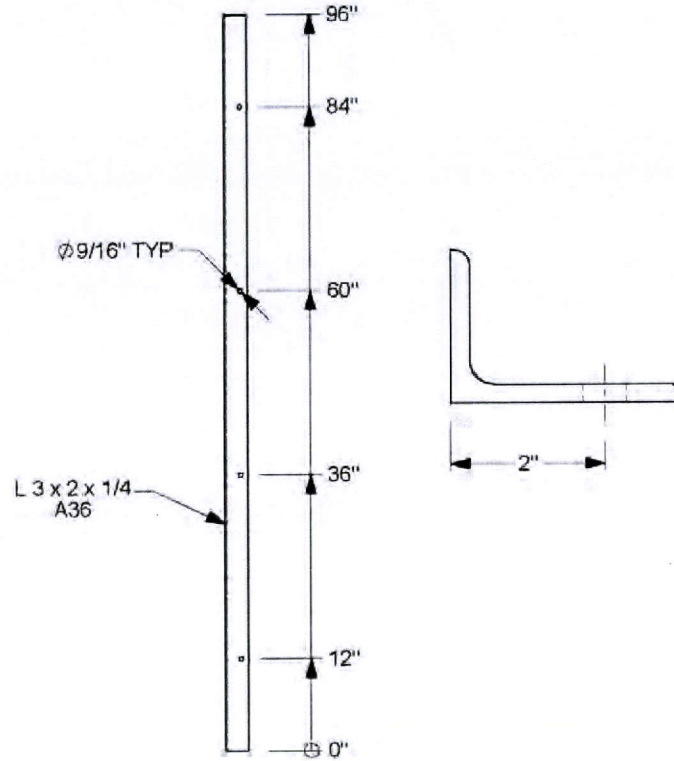

Roadside Safety and Physical Security Division - Proving Ground

Project 467823-1, 2,	Ground Mounted Timber Support	2013-05-06
Drawn By GES	Scale 1:40	Sheet 3 of 3 Post and Stiffener Details

APPENDIX B. CRASH TEST NO. 467823-1

B.1 TEST VEHICLE PROPERTIES AND INFORMATION

Table B1. Vehicle Properties for Test No. 467823-1.

Date: 2013-05-22 Test No.: 467823-1 VIN No.: KNADE123X863369048
 Year: 2008 Make: Kia Model: Rio
 Tire Inflation Pressure: 32 psi Odometer: 94646 Tire Size: P175/70R14

Describe any damage to the vehicle prior to test: _____

• Denotes accelerometer location.

NOTES: _____

Engine Type: 4 cylinder
 Engine CID: 1.6 liter
 Transmission Type:
 Auto or Manual
 FWD RWD 4WD
 Optional Equipment:
None

Dummy Data:
 Type: 50th Percentile Male
 Mass: 169 lb
 Seat Position: Driver

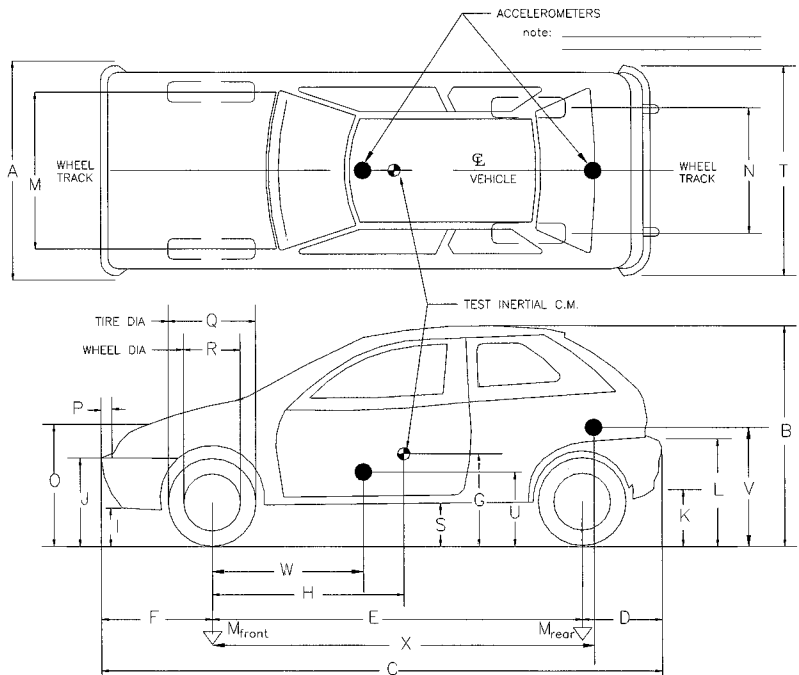

Geometry: inches

A	<u>66.38</u>	F	<u>33.00</u>	K	<u>11.00</u>	P	<u>4.12</u>	U	<u>14.00</u>
B	<u>57.75</u>	G	<u>---</u>	L	<u>24.12</u>	Q	<u>22.19</u>	V	<u>22.00</u>
C	<u>165.25</u>	H	<u>38.93</u>	M	<u>57.75</u>	R	<u>15.38</u>	W	<u>45.00</u>
D	<u>34.00</u>	I	<u>7.12</u>	N	<u>57.12</u>	S	<u>7.62</u>	X	<u>107.00</u>
E	<u>98.75</u>	J	<u>21.00</u>	O	<u>30.62</u>	T	<u>66.12</u>		
Wheel Center Ht Front		<u>11.00</u>		Wheel Center Ht Rear		<u>11.00</u>			

GVWR Ratings:	Mass: lb	Curb	Test Inertial	Gross Static
Front	<u>1918</u>	M_{front}	<u>1480</u>	<u>1570</u>
Back	<u>1874</u>	M_{rear}	<u>963</u>	<u>1042</u>
Total	<u>3638</u>	M_{Total}	<u>2443</u>	<u>2612</u>

Allowable TIM = 2420 lb ±55 lb | Allowable GSM = 2585 lb ± 55 lb

Mass Distribution:

lb LF: 750 RF: 730 LR: 482 RR: 481

Table B2. Vehicle Exterior Crush Measurements for Test No. 467823-1.

Date: 2013-05-22 Test No.: 467823-1 VIN No.: KNADE123X863369048
 Year: 2008 Make: Kia Model: Rio

VEHICLE CRUSH MEASUREMENT SHEET¹

Complete When Applicable	
End Damage	Side Damage
Undeformed end width _____ Corner shift: A1 _____ A2 _____ End shift at frame (CDC) (check one) < 4 inches _____ ≥ 4 inches _____	Bowing: B1 _____ X1 _____ B2 _____ X2 _____ Bowing constant $\frac{X1 + X2}{2} = \underline{\hspace{2cm}}$

Note: Measure C₁ to C₆ from Driver to Passenger side in Front or Rear impacts – Rear to Front in Side Impacts.

Specific Impact Number	Plane* of C-Measurements	Direct Damage		Field L**	C ₁	C ₂	C ₃	C ₄	C ₅	C ₆	±D
		Width** (CDC)	Max*** Crush								
1	Front plane at bumper ht	---	2.0	----	----	----	----	----	----	----	----
	Measurements recorded										
	in inches										

¹Table taken from National Accident Sampling System (NASS).

*Identify the plane at which the C-measurements are taken (e.g., at bumper, above bumper, at sill, above sill, at beltline, etc.) or label adjustments (e.g., free space).

Free space value is defined as the distance between the baseline and the original body contour taken at the individual C locations. This may include the following: bumper lead, bumper taper, side protrusion, side taper, etc. Record the value for each C-measurement and maximum crush.

**Measure and document on the vehicle diagram the beginning or end of the direct damage width and field L (e.g., side damage with respect to undamaged axle).

***Measure and document on the vehicle diagram the location of the maximum crush.

Note: Use as many lines/columns as necessary to describe each damage profile.

Table B3. Occupant Compartment Measurements for Test No. 467823-1.

Date: 2013-05-22 Test No.: 467823-1 VIN No.: KNADE123X863369048
 Year: 2008 Make: Kia Model: Rio

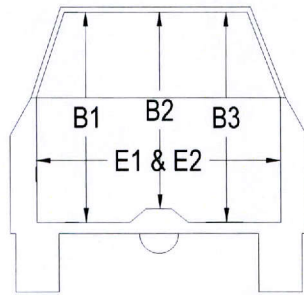
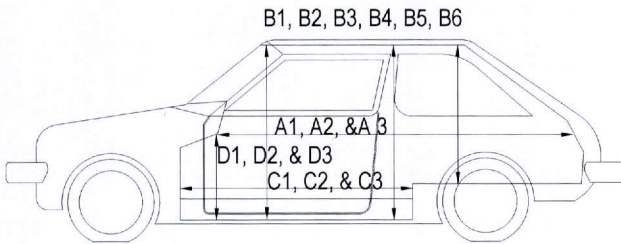
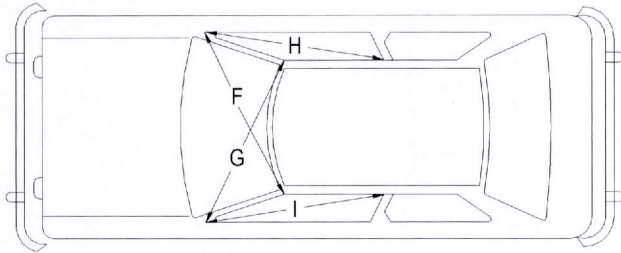

OCCUPANT COMPARTMENT DEFORMATION MEASUREMENT

	Before (inches)	After (inches)
A1	68.00	68.00
A2	67.00	67.00
A3	68.00	68.00
B1	40.50	40.00
B2	35.50	34.50
B3	40.50	40.00
B4	31.75	28.25
B5	32.50	30.25
B6	31.75	31.25
C1	27.00	27.00
C2	---	---
C3	26.00	26.00
D1	9.50	9.50
D2	---	---
D3	9.75	9.75
E1	52.00	52.00
E2	51.00	51.00
F	50.00	50.00
G	50.00	50.00
H	37.00	37.00
I	37.00	37.00
J*	50.75	50.75

*Lateral area across the cab from driver's side kickpanel to passenger's side kickpanel.

B.2 SEQUENTIAL PHOTOGRAPHS



0.000 s

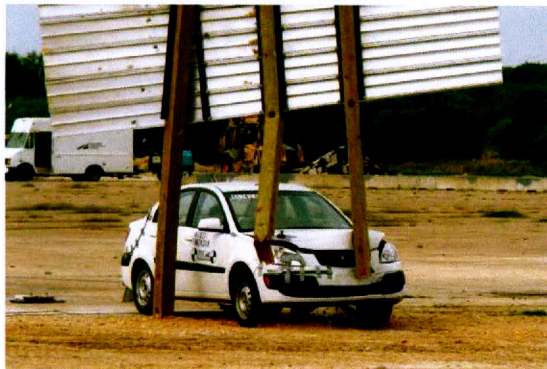

0.378 s

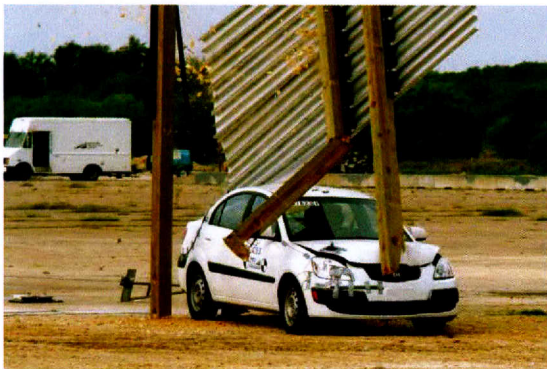

0.756 s

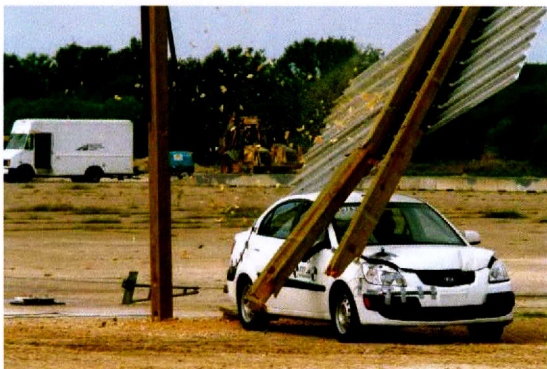

1.134 s



Figure B1. Sequential Photographs for Test No. 467823-1(Oblique and Perpendicular Views).

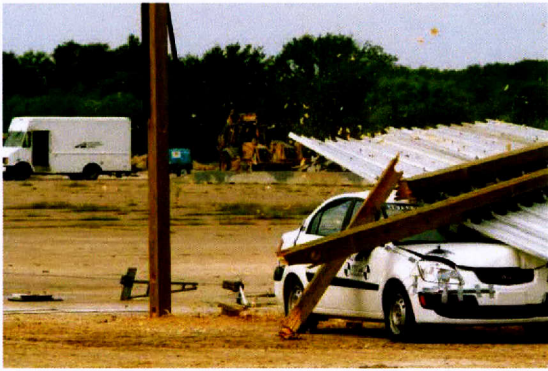

1.512 s



1.890 s



2.268 s



2.646 s

Out of view

Figure B1. Sequential Photographs for Test No. 467823-1(Oblique and Perpendicular Views) (Continued).

Roll, Pitch, and Yaw Angles

B.3 ANGULAR DISPLACEMENTS

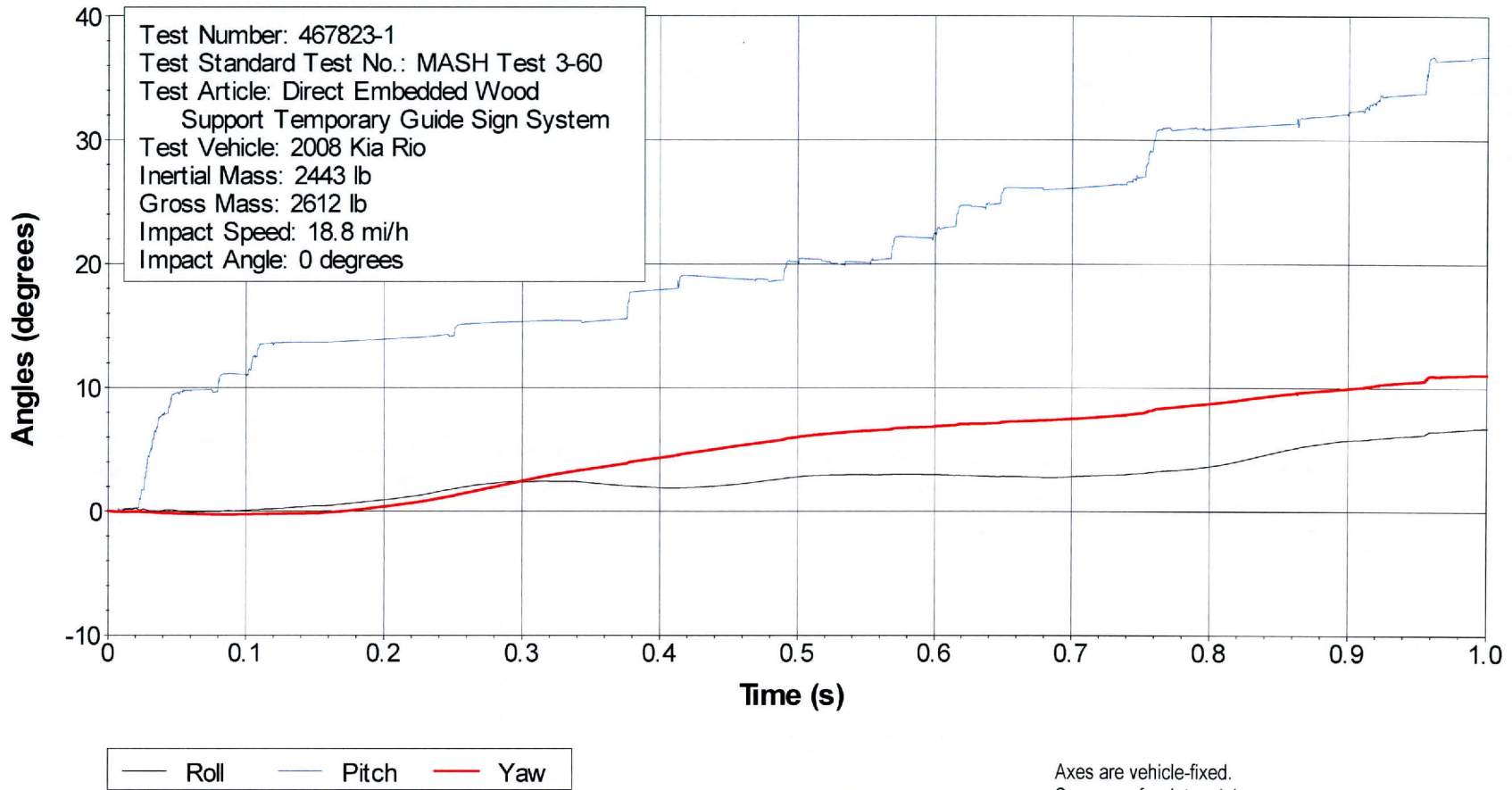

Test Number: 467823-1
 Test Standard Test No.: MASH Test 3-60
 Test Article: Direct Embedded Wood Support Temporary Guide Sign System
 Test Vehicle: 2008 Kia Rio
 Inertial Mass: 2443 lb
 Gross Mass: 2612 lb
 Impact Speed: 18.8 mi/h
 Impact Angle: 0 degrees

Axes are vehicle-fixed.
 Sequence for determining orientation:

1. Yaw.
2. Pitch.
3. Roll.

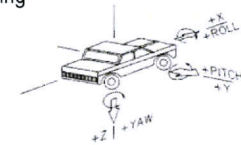

Figure B2. Vehicle Angular Displacements for Test No. 467823-1.

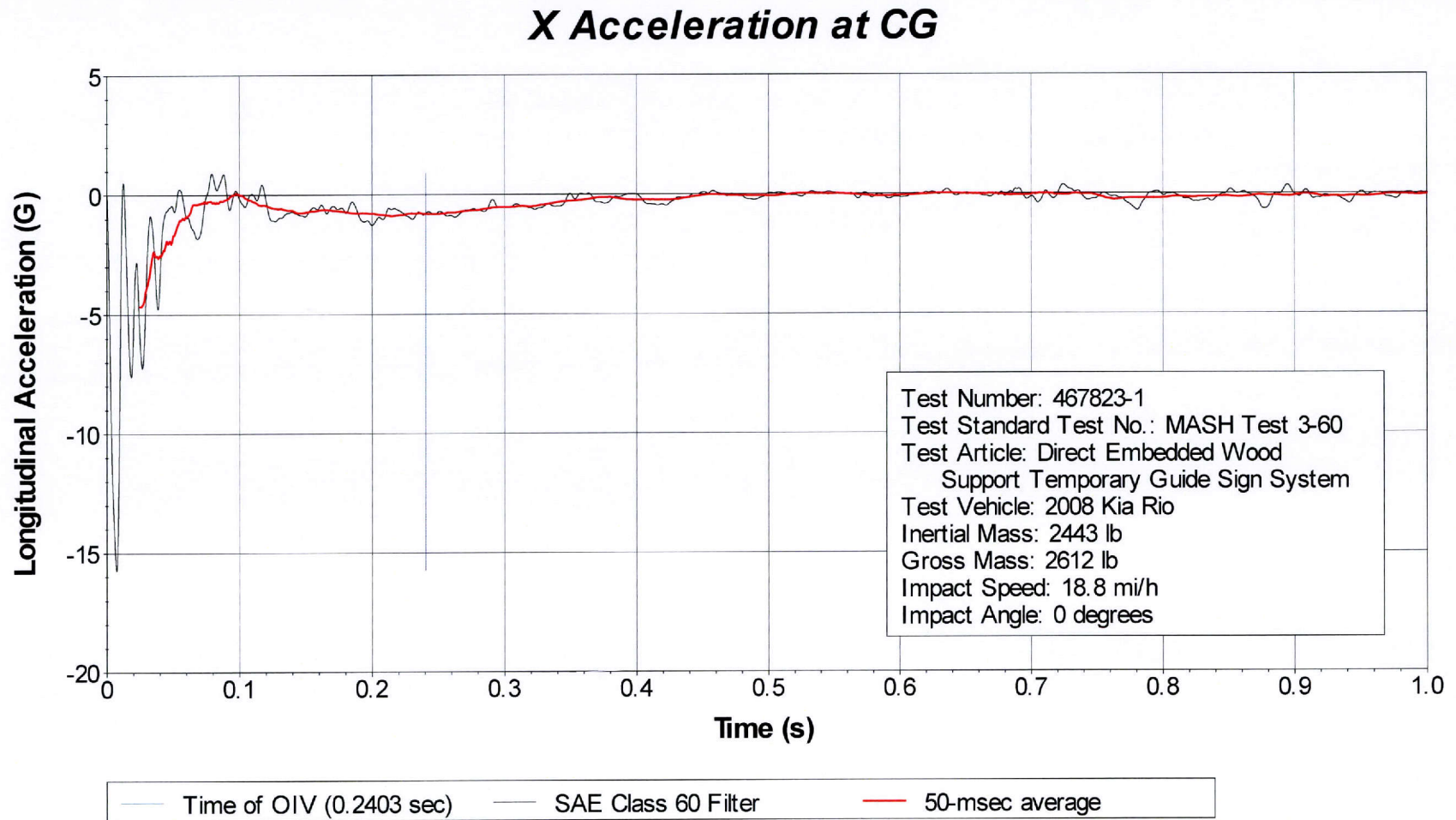

Figure B3. Vehicle Longitudinal Accelerometer Trace for Test No. 467823-1 (Accelerometer Located at Center of Gravity).

Y Acceleration at CG

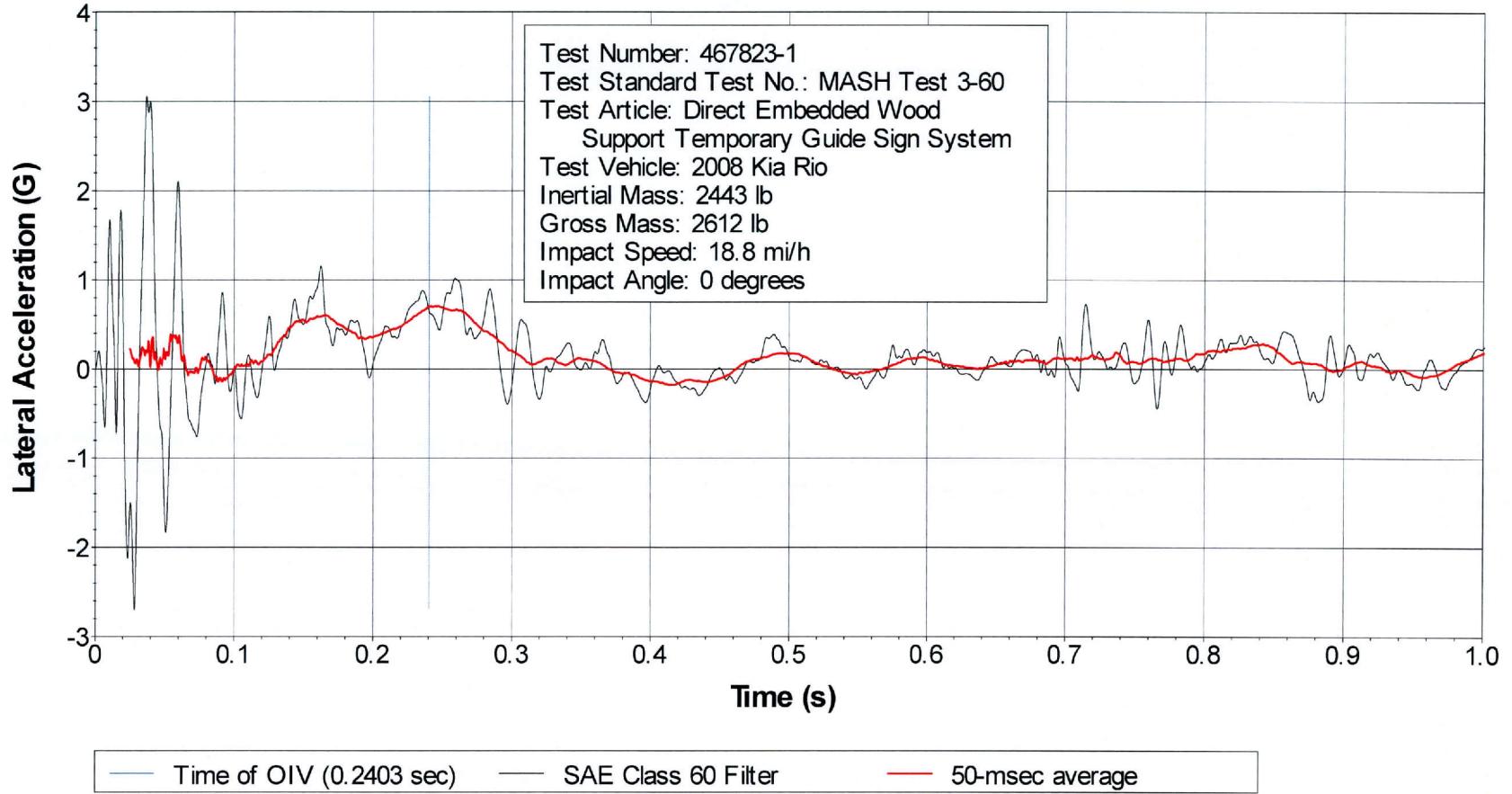

Figure B4. Vehicle Lateral Accelerometer Trace for Test No. 467823-1 (Accelerometer Located at Center of Gravity).

Z Acceleration at CG

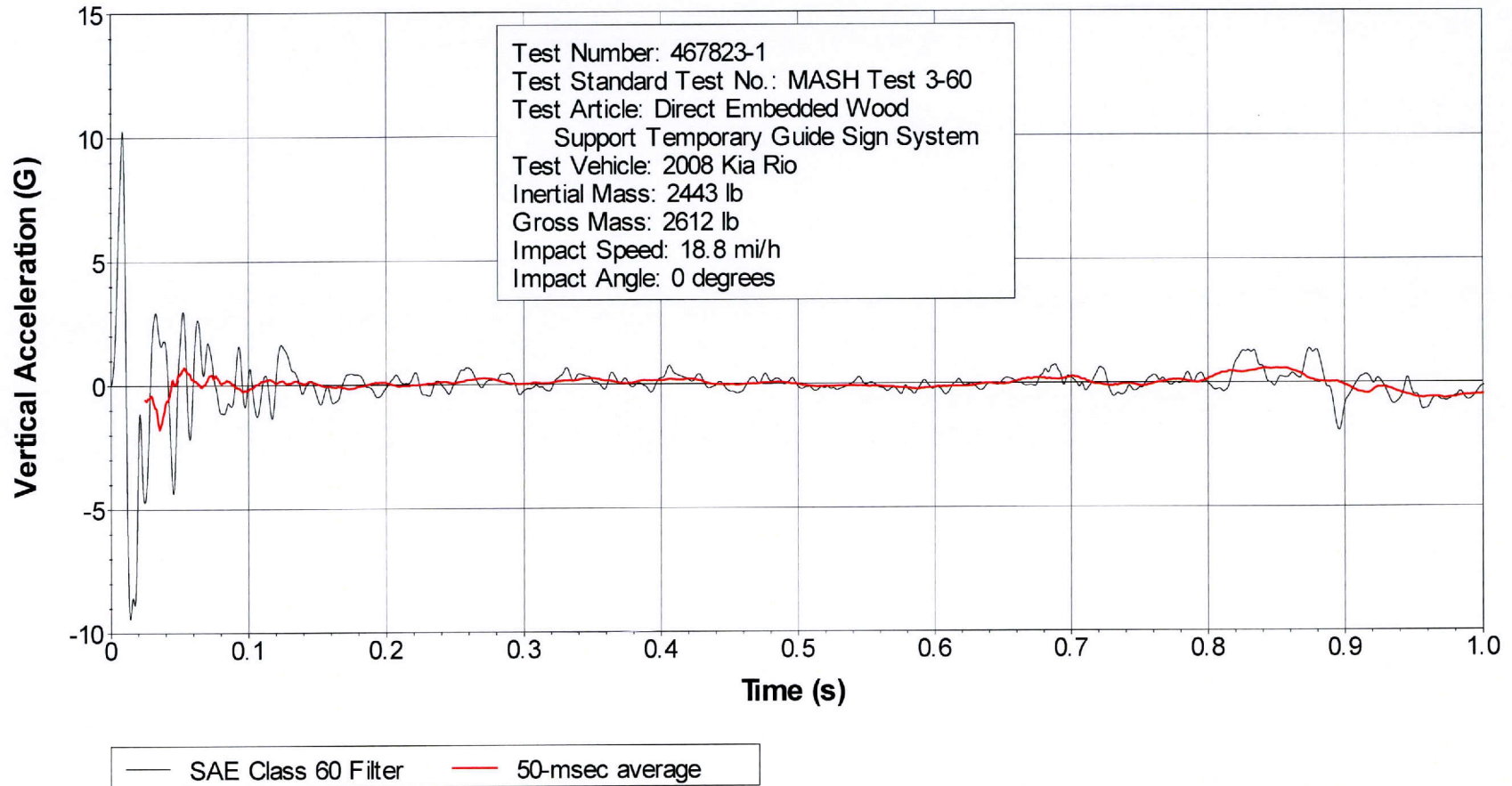

Figure B5. Vehicle Vertical Accelerometer Trace for Test No. 467823-1 (Accelerometer Located at Center of Gravity).

X Acceleration Rear of CG

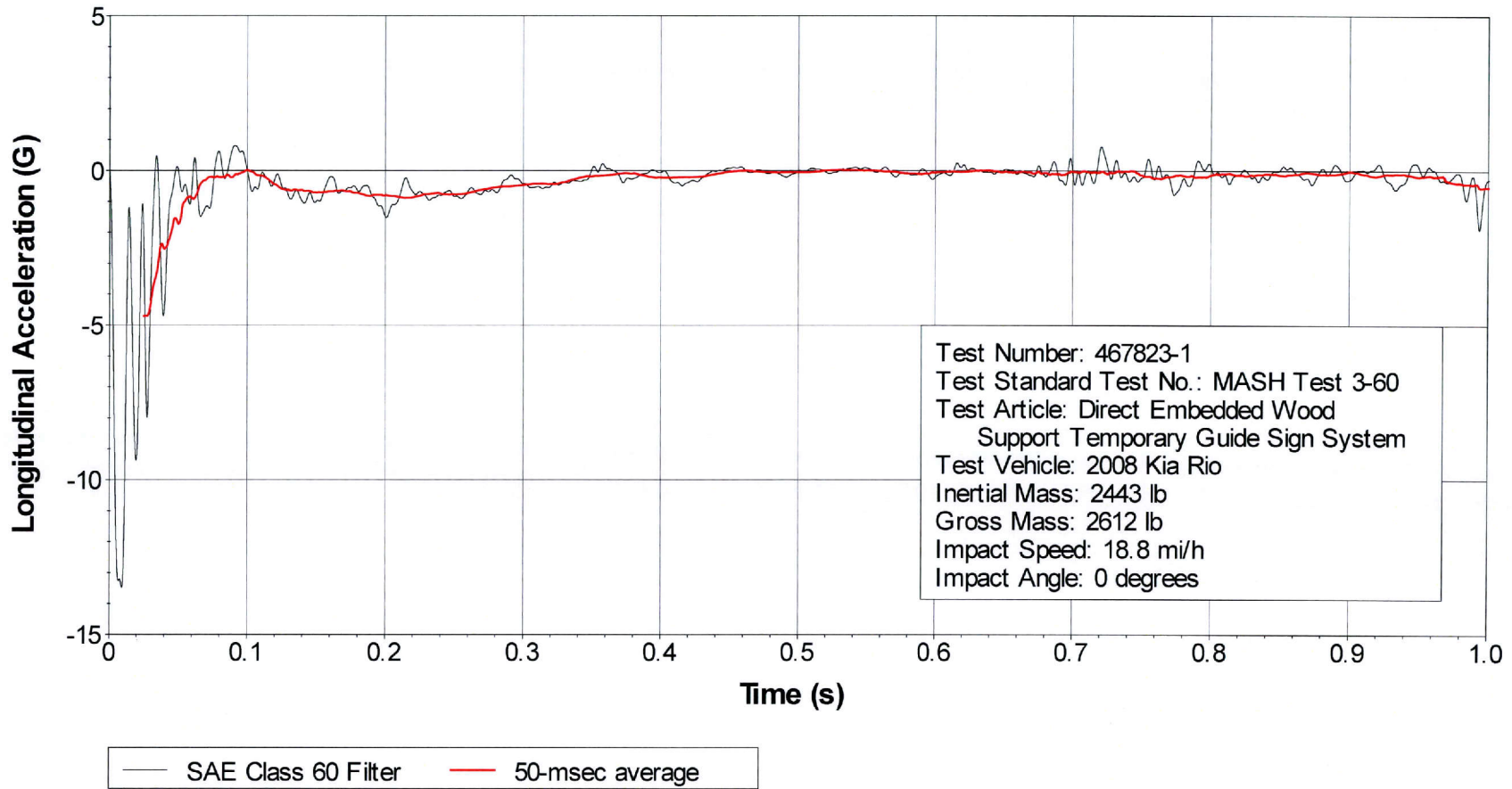

Figure B6. Vehicle Longitudinal Accelerometer Trace for Test No. 467823-1 (Accelerometer Located Rear of Center of Gravity).

Y Acceleration Rear of CG

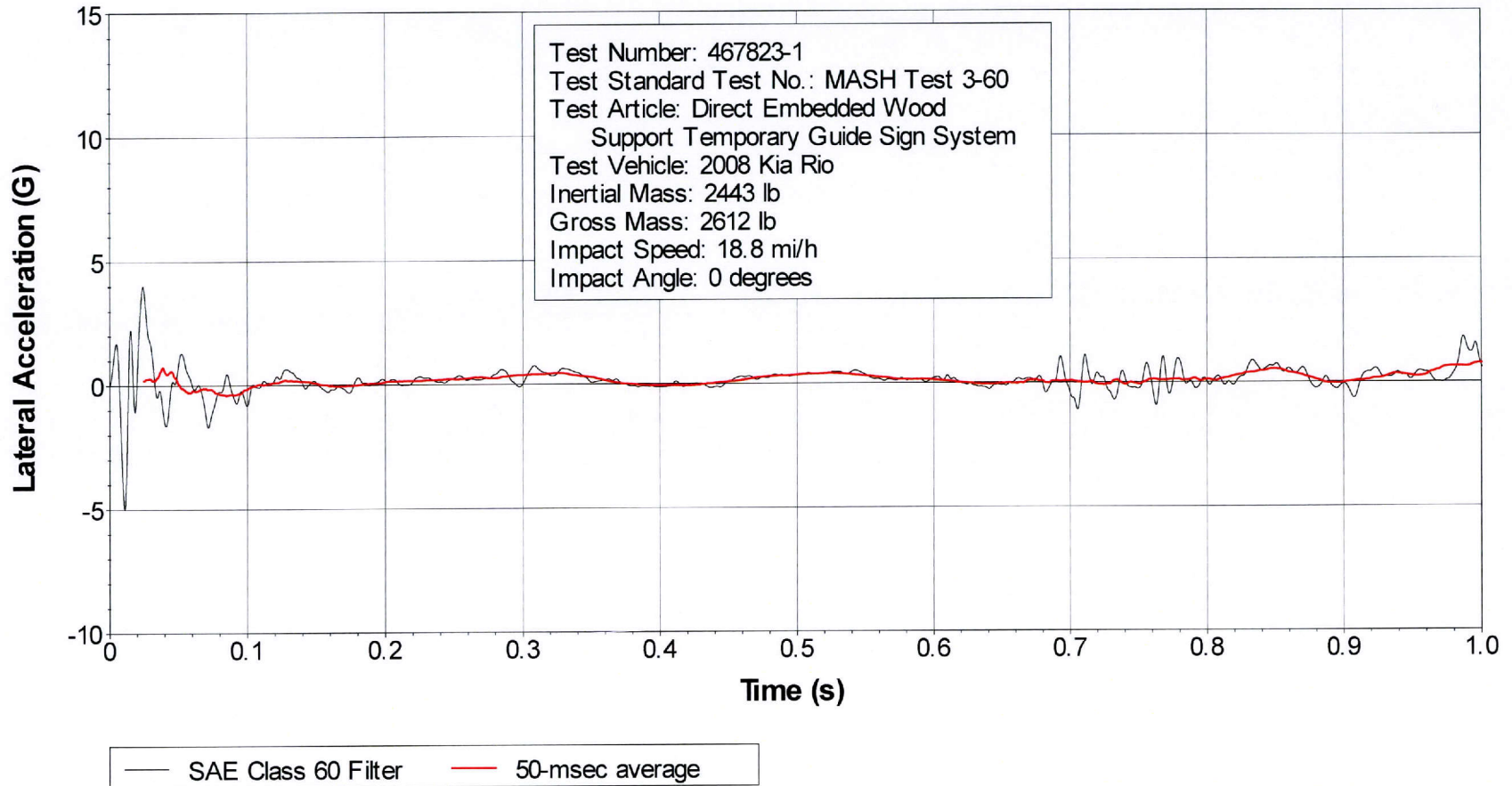

Figure B7. Vehicle Lateral Accelerometer Trace for Test No. 467823-1 (Accelerometer Located Rear of Center of Gravity).

Z Acceleration at CG

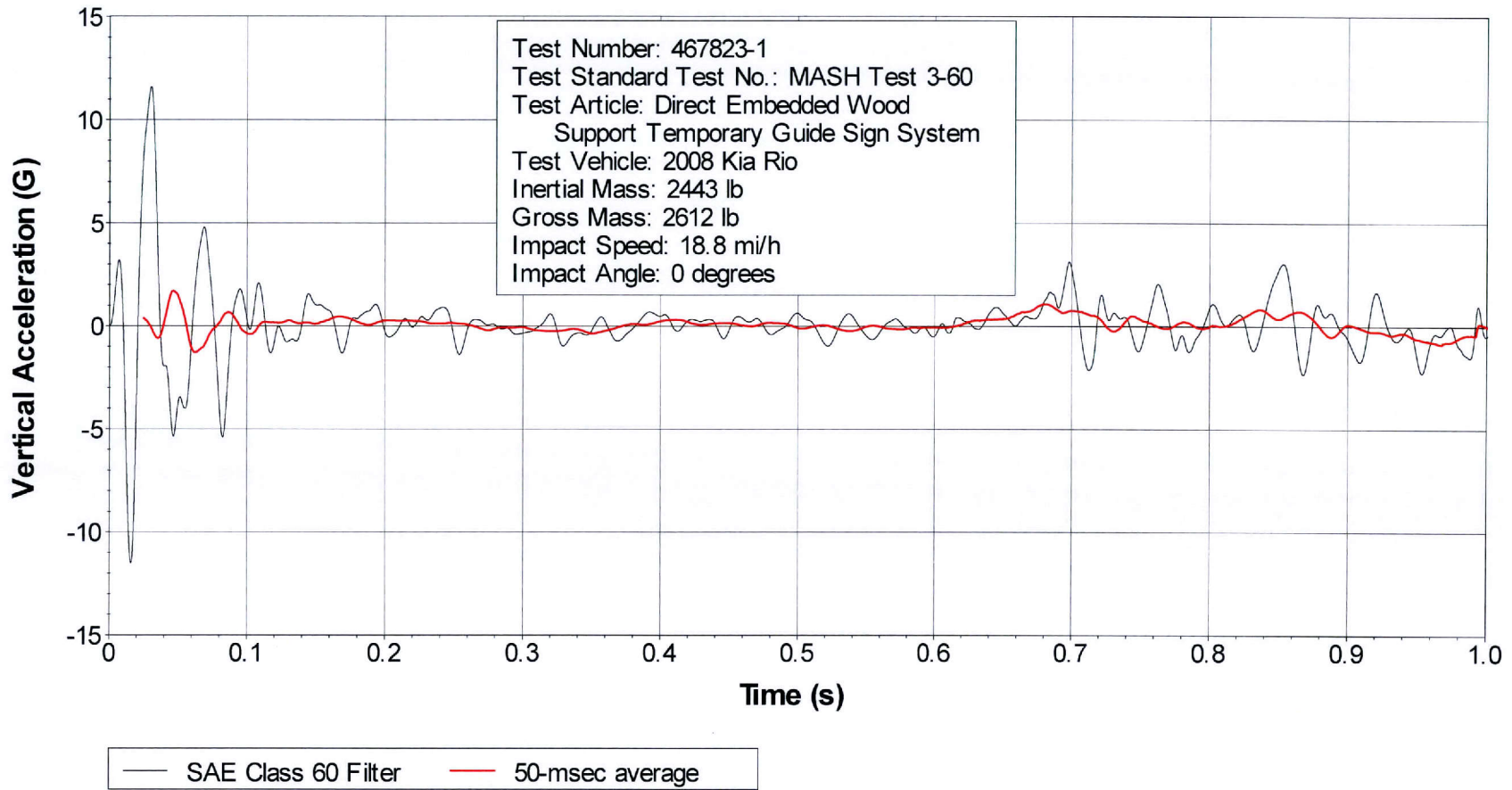

Figure B8. Vehicle Vertical Accelerometer Trace for Test No. 467823-1 (Accelerometer Located Rear of Center of Gravity).

APPENDIX C. CRASH TEST NO. 467823-2

C.1 TEST VEHICLE PROPERTIES AND INFORMATION

Table C1. Vehicle Properties for Test No. 467823-2.

Date: 2013-05-22 Test No.: 467823-2 VIN No.: KNADE123066079589
 Year: 2008 Make: Kia Model: Rio
 Tire Inflation Pressure: 32 psi Odometer: 133208 Tire Size: P175/70R14

Describe any damage to the vehicle prior to test: _____

• Denotes accelerometer location.

NOTES: _____

Engine Type: 4 cylinder
 Engine CID: 1.6 liter
 Transmission Type:
 Auto or Manual
 FWD RWD 4WD
 Optional Equipment:
None

Dummy Data:
 Type: 50th percentile male
 Mass: 179 lb
 Seat Position: Driver

Geometry: inches

A	<u>66.38</u>	F	<u>33.00</u>	K	<u>11.00</u>	P	<u>4.12</u>	U	<u>14.00</u>
B	<u>57.75</u>	G	<u>----</u>	L	<u>24.12</u>	Q	<u>22.19</u>	V	<u>22.00</u>
C	<u>165.75</u>	H	<u>35.12</u>	M	<u>57.75</u>	R	<u>15.38</u>	W	<u>45.00</u>
D	<u>34.00</u>	I	<u>7.12</u>	N	<u>57.12</u>	S	<u>7.62</u>	X	<u>107.00</u>
E	<u>98.75</u>	J	<u>21.00</u>	O	<u>30.62</u>	T	<u>66.12</u>		

Wheel Center Ht Front 11.00 Wheel Center Ht Rear 11.00

GVWR Ratings:	Mass: lb	Curb	Test Inertial	Gross Static
Front <u>1918</u>	M_{front}	<u>1610</u>	<u>1567</u>	<u>1655</u>
Back <u>1874</u>	M_{rear}	<u>922</u>	<u>865</u>	<u>956</u>
Total <u>3638</u>	M_{Total}	<u>2532</u>	<u>2432</u>	<u>2611</u>

Allowable TIM = 2420 lb ±55 lb | Allowable GSM = 2585 lb ± 55 lb

Mass Distribution:

lb LF: 800 RF: 767 LR: 425 RR: 440

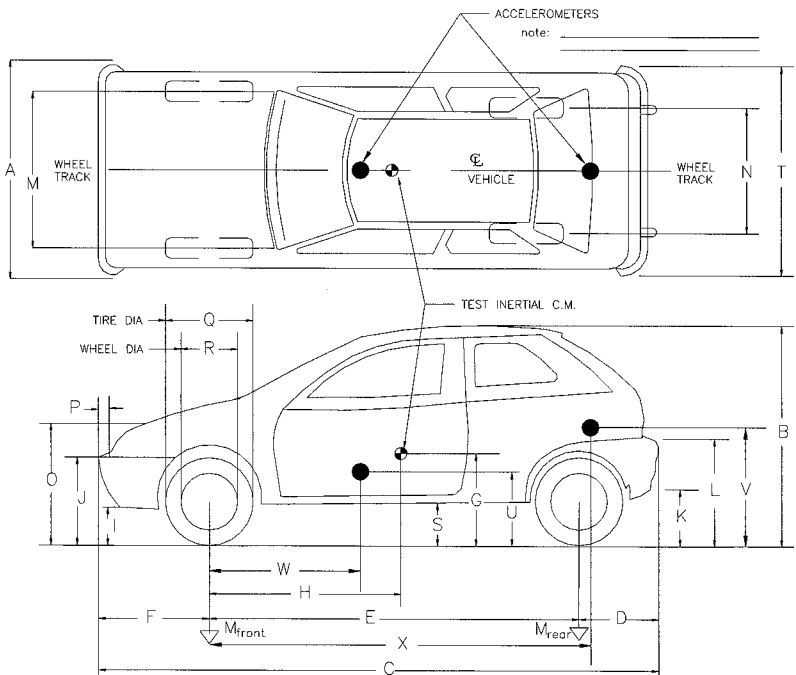
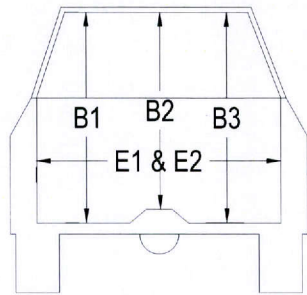
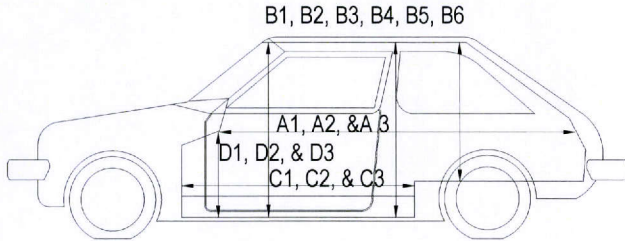
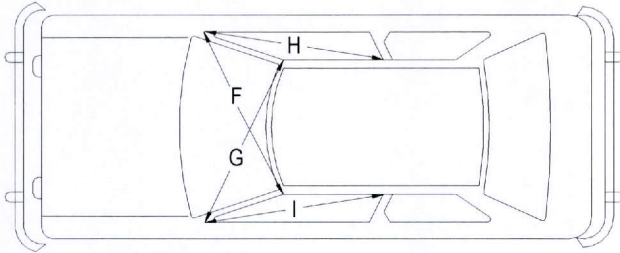

Table C3. Occupant Compartment Measurements for Test No. 467823-2.

Date: 2013-05-22 Test No.: 467823-2 VIN No.: KNADE123066079589
 Year: 2008 Make: Kia Model: Rio



OCCUPANT COMPARTMENT DEFORMATION MEASUREMENT

	Before (inches)	After (inches)
A1	68.00	68.00
A2	66.25	66.25
A3	68.00	68.00
B1	40.25	40.25
B2	36.25	36.25
B3	40.25	40.25
B4	37.50	37.50
B5	37.00	37.00
B6	37.50	37.50
C1	27.00	27.00
C2	----	----
C3	27.50	27.50
D1	9.50	9.50
D2	----	----
D3	9.50	9.50
E1	52.00	52.00
E2	51.25	51.25
F	51.00	51.00
G	51.00	51.00
H	37.50	37.50
I	37.50	37.50
J*	51.00	51.00

*Lateral area across the cab from driver's side kickpanel to passenger's side kickpanel.

C.2 SEQUENTIAL PHOTOGRAPHS



0.000 s



0.076 s



0.152 s

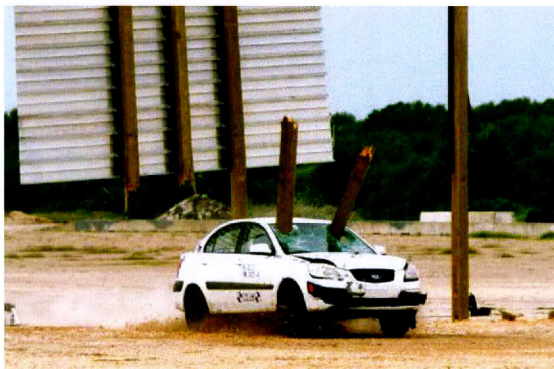

0.228 s



Figure C1. Sequential Photographs for Test No. 467823-2(Oblique and Perpendicular Views).



0.304 s



0.380 s



0.456 s



0.532 s

Vehicle out of view

Figure C1. Sequential Photographs for Test No. 467823-2 (Oblique and Perpendicular Views) (Continued).

Roll, Pitch, and Yaw Angles

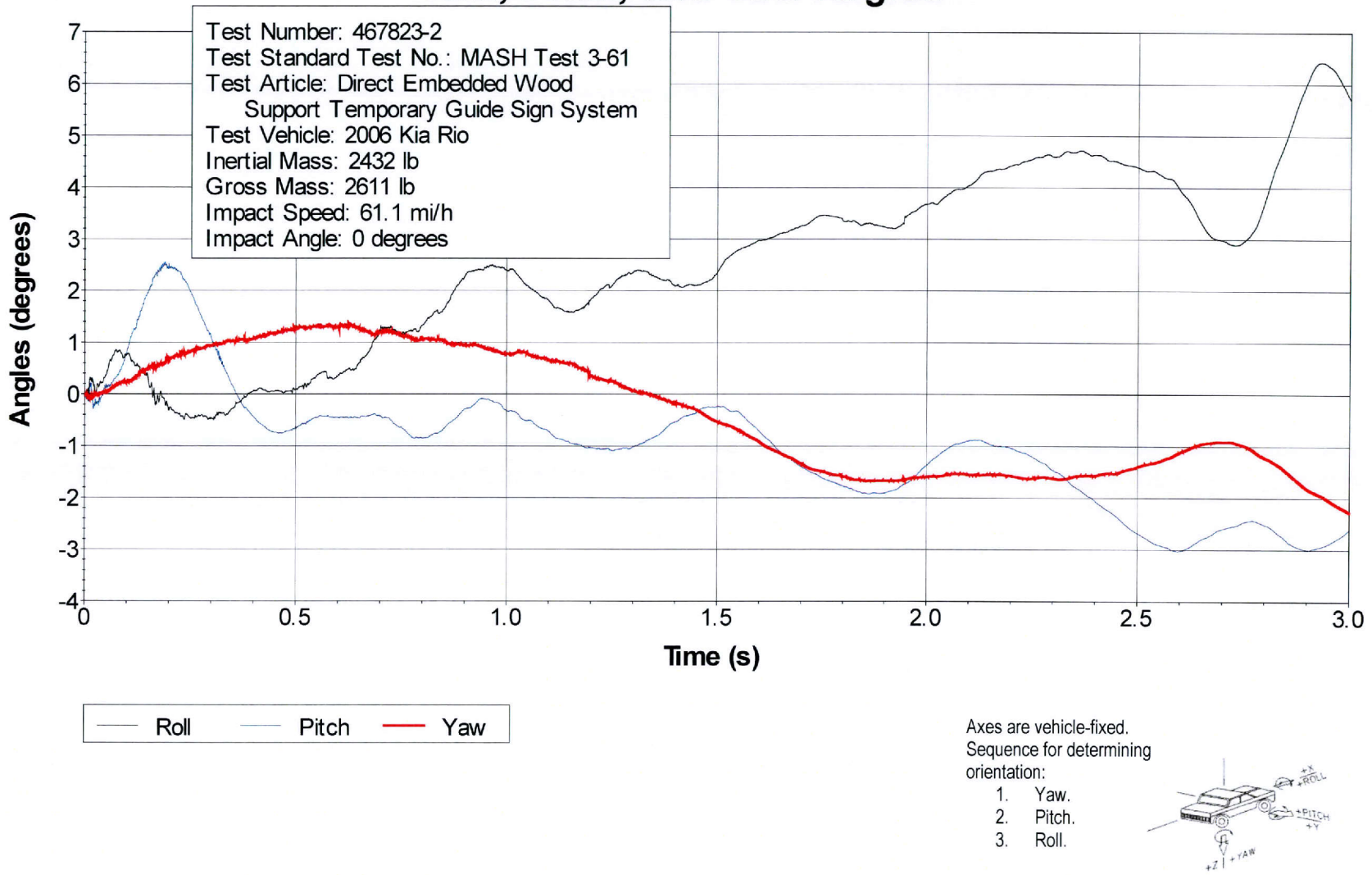
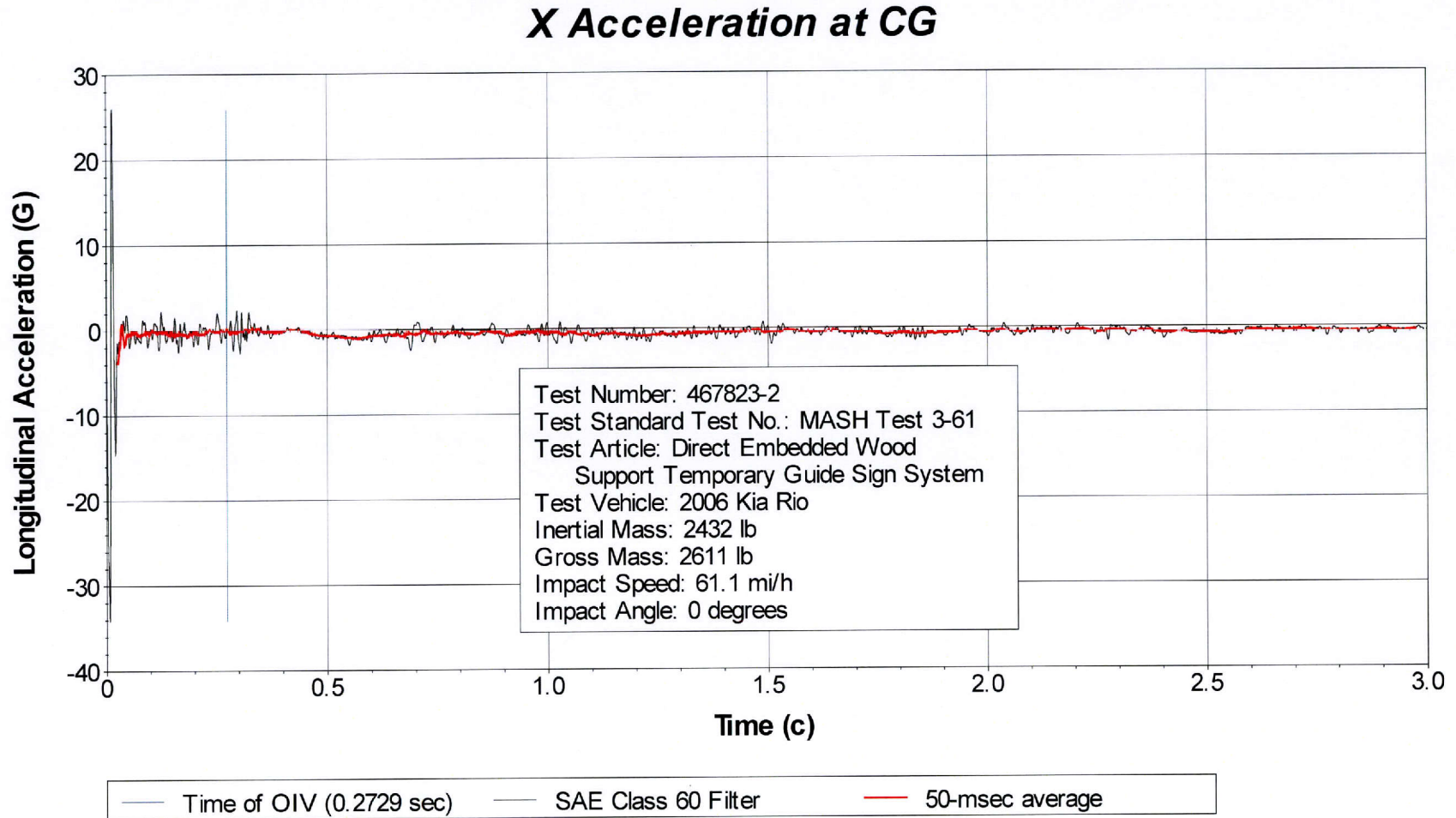

Figure C2. Vehicle Angular Displacements for Test No. 467823-2.



**Figure C3. Vehicle Longitudinal Accelerometer Trace for Test No. 467823-2
(Accelerometer Located at Center of Gravity).**

Y Acceleration at CG

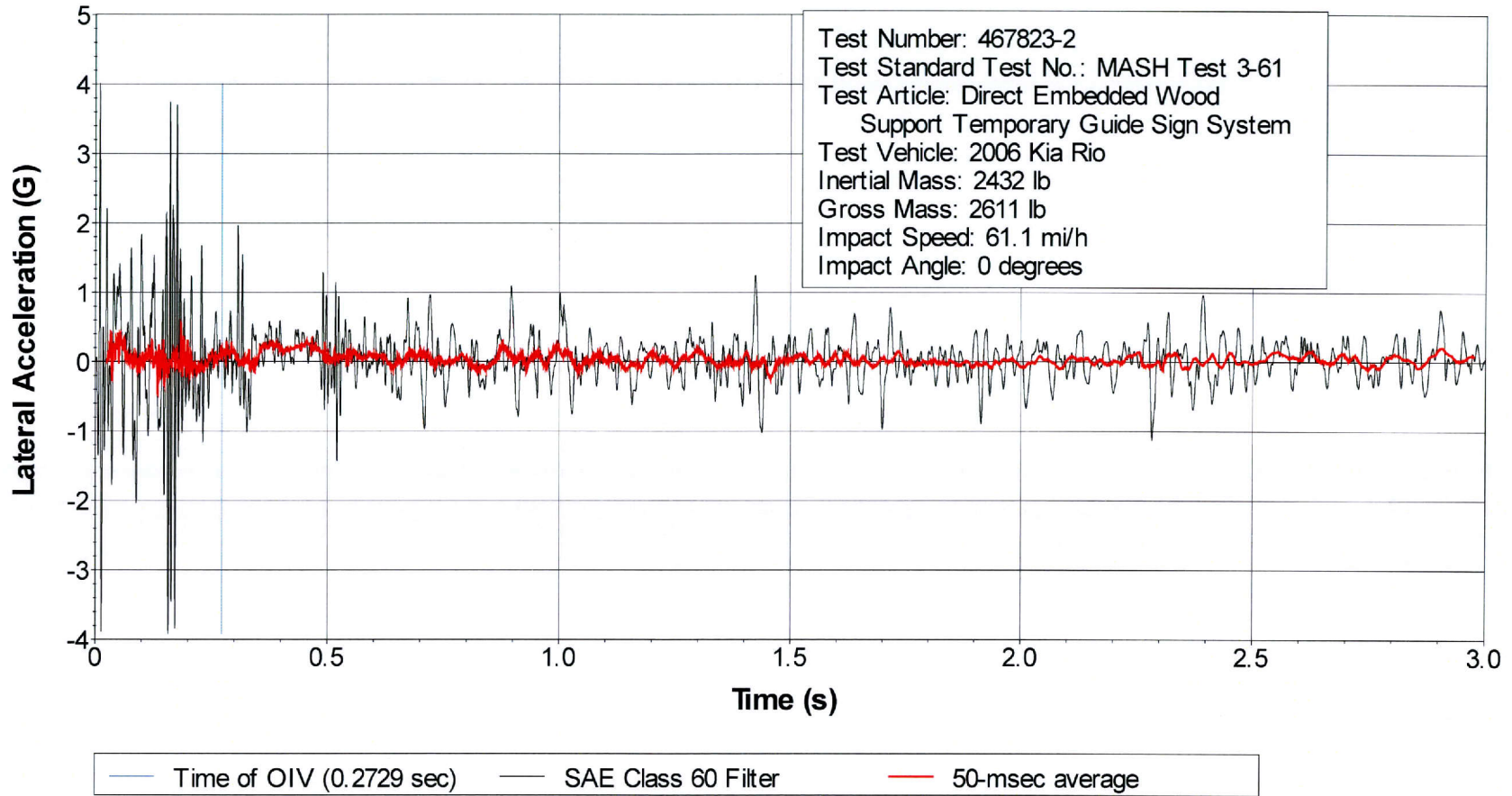

Figure C4. Vehicle Lateral Accelerometer Trace for Test No. 467823-2 (Accelerometer Located at Center of Gravity).

Z Acceleration at CG

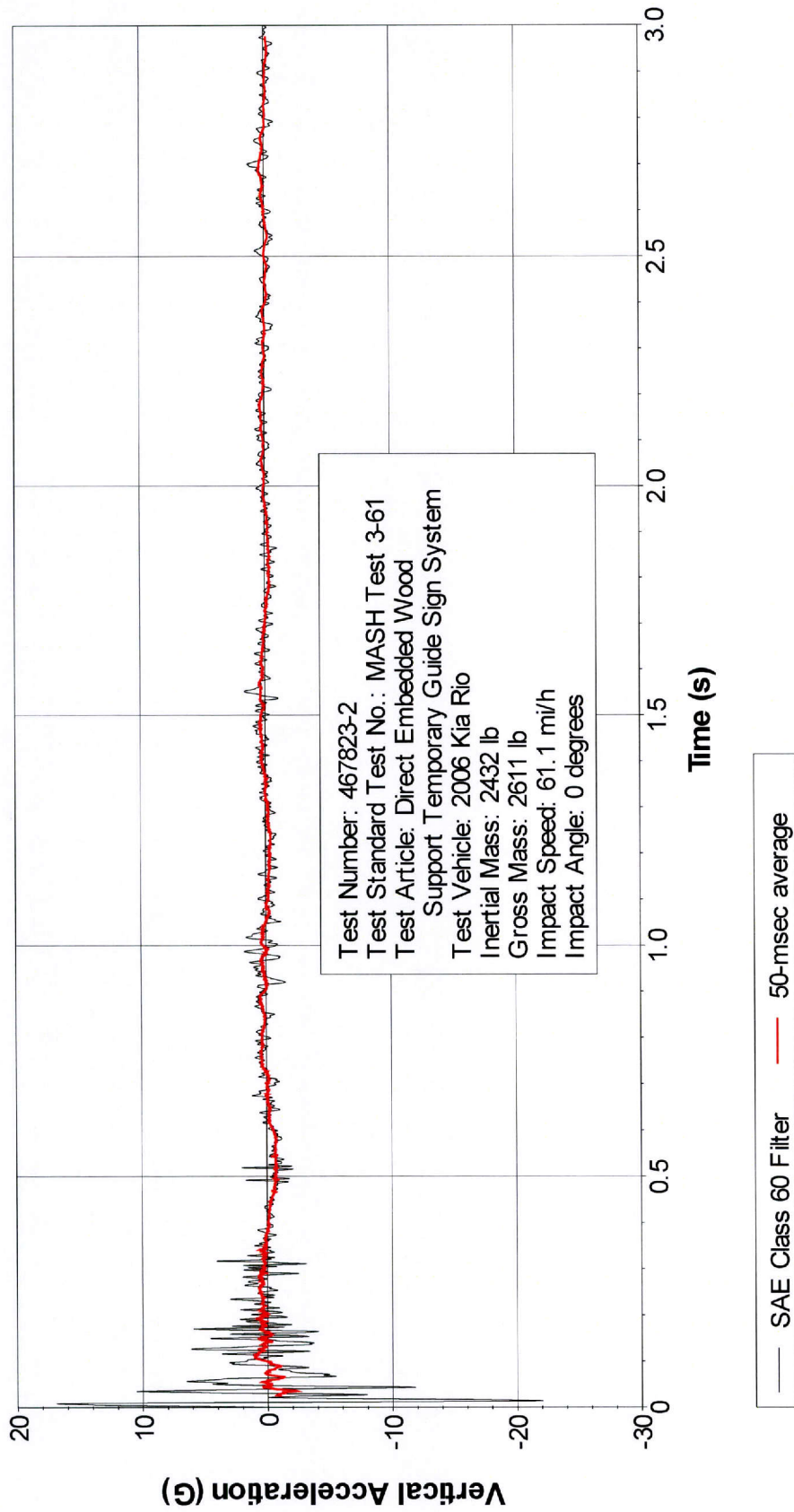
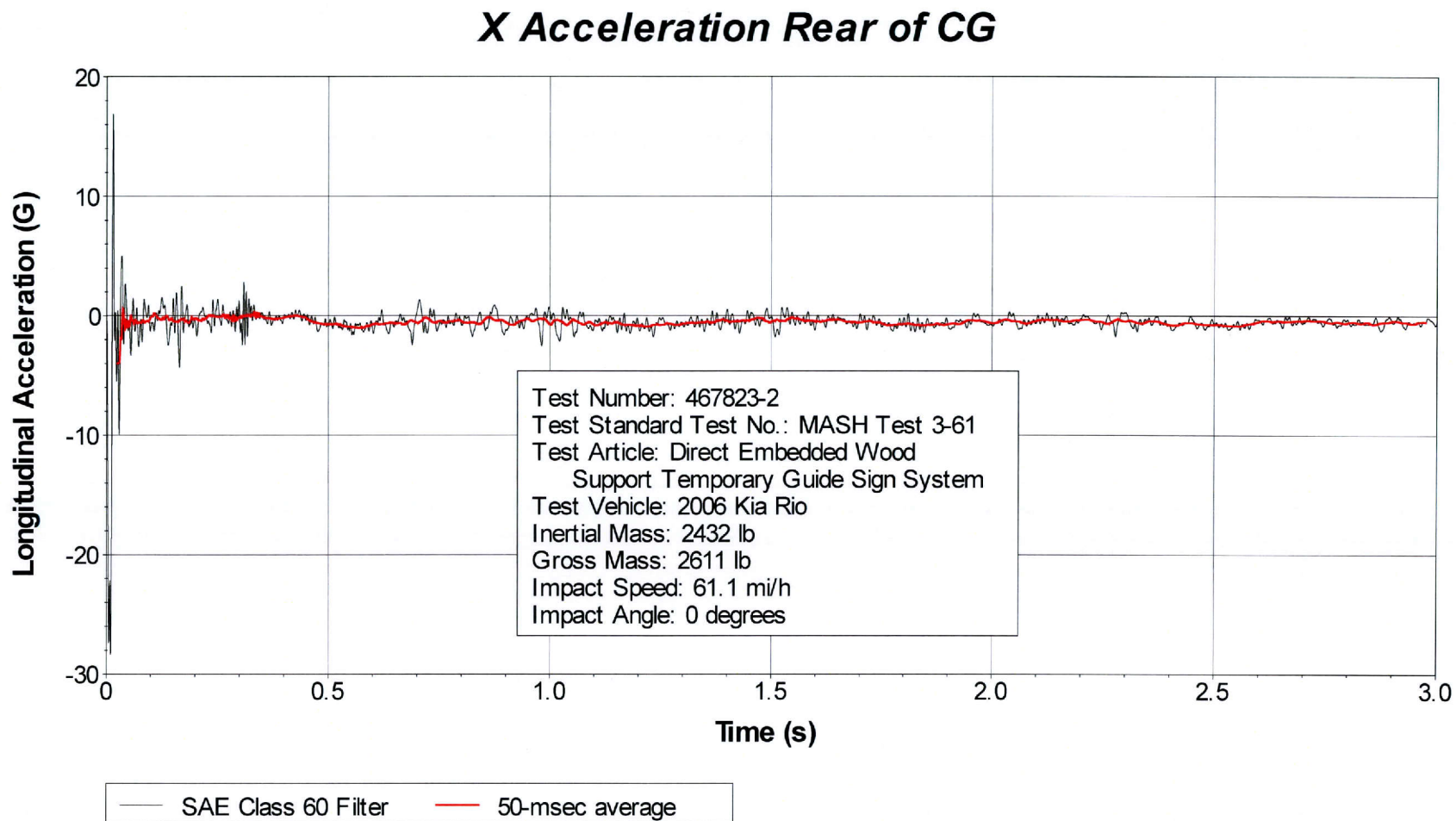

Figure C5. Vehicle Vertical Accelerometer Trace for Test No. 467823-2 (Accelerometer Located at Center of Gravity).



**Figure C6. Vehicle Longitudinal Accelerometer Trace for Test No. 467823-2
(Accelerometer Located Rear of Center of Gravity).**

Y Acceleration Rear of CG

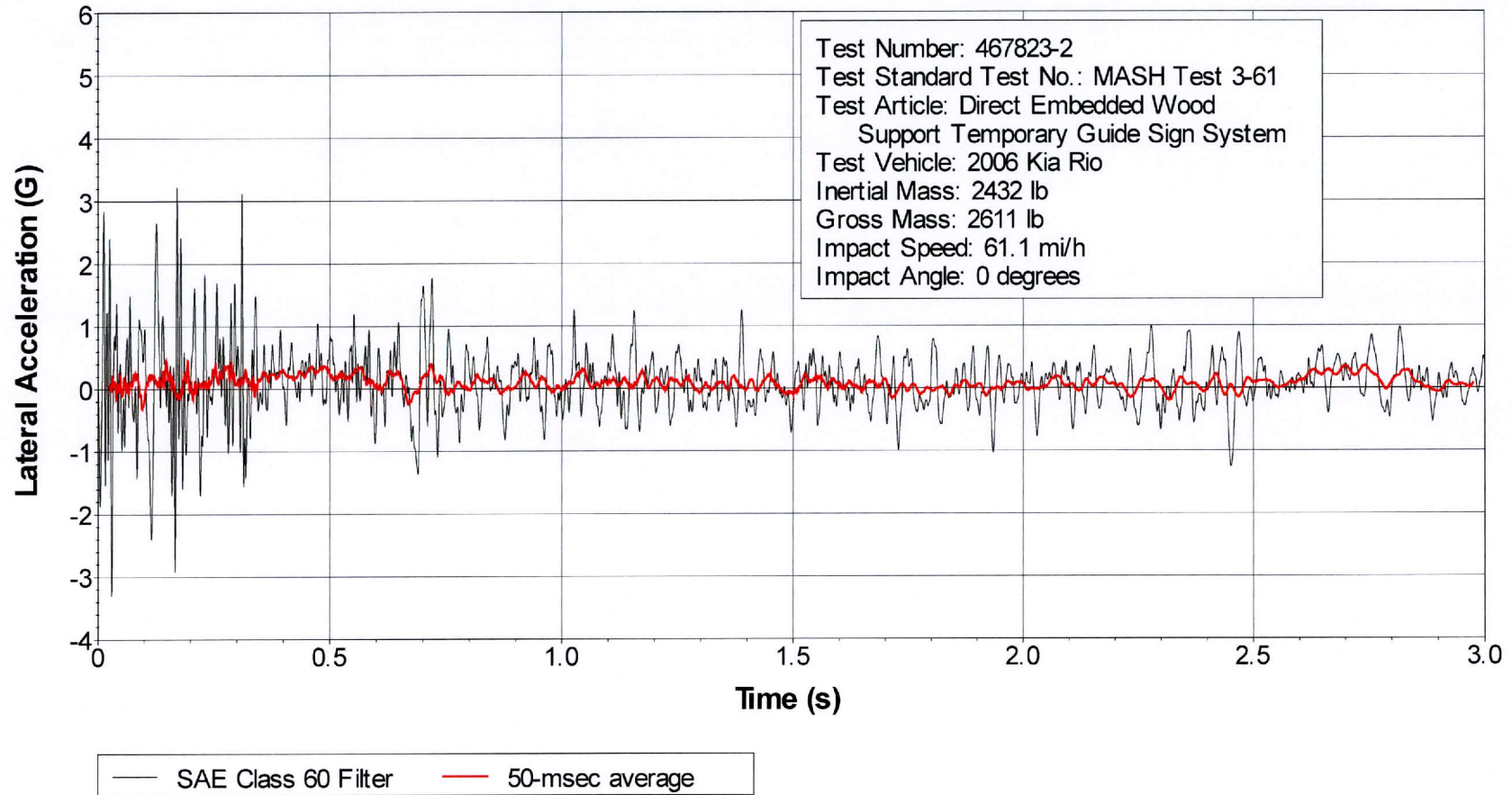

Figure C7. Vehicle Lateral Accelerometer Trace for Test No. 467823-2 (Accelerometer Located Rear of Center of Gravity).

Z Acceleration Rear of CG

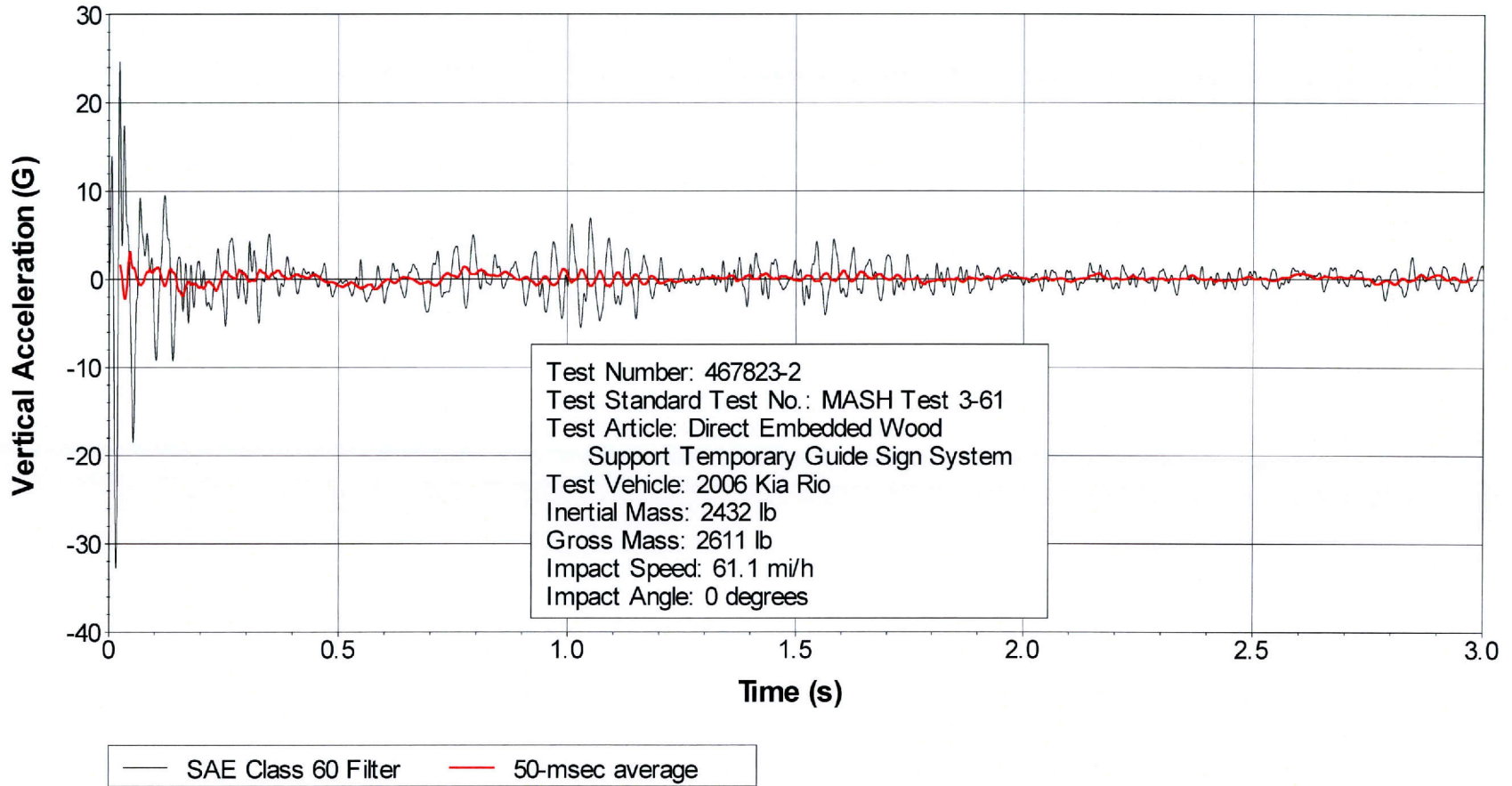
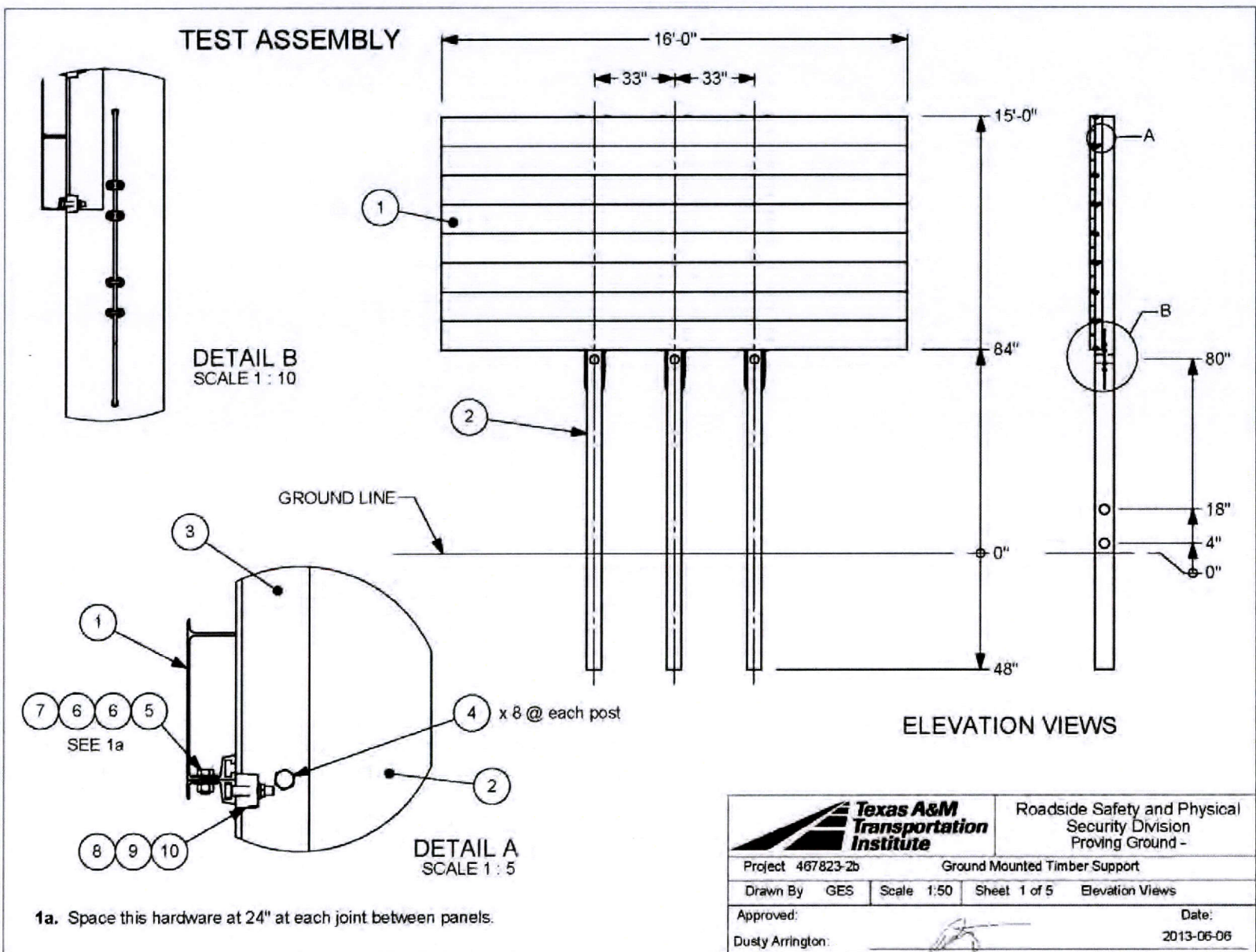

Figure C8. Vehicle Vertical Accelerometer Trace for Test No. 467823-2 (Accelerometer Located Rear of Center of Gravity).

**APPENDIX D. DETAILS OF THE MODIFIED DIRECT EMBEDDED
WOOD SUPPORT TEMPORARY GUIDE SIGN SYSTEM**

T:\2012-2013\467823-2b\Drawings\Temp Sign Support\467823-2b\DOT\DOC\Temp Sign Support\467823-2b Drawing



INSTALLATION PARTS			
#	PART NAME	DETAILS	QTY.
1	Aluminum Sign Panel, 12" x 16'	see TxDOT Drawing SMD (2-1) -08	8
2	Timber Post	sheet 4	3
3	Angle Stiffener	sheet 4	6
4	1/2 x 3 Lag Bolt	A307	24
5	Bolt, 3/8 x 3/4 hex	grade 2	56
6	Washer, 3/8 flat		112
7	Nut, 3/8 hex		56
8	Nut, 3/8 flange		54
9	Bolt, 3/8 x 1-3/4 square head	see TxDOT Drawing SMD (2-1) -08	54
10	Sign Clip	see TxDOT Drawing SMD (2-1) -08	54
11	Ø1/4" Wire Rope	78" long	3
12	Forged Wire Rope Clip for 1/4" wire rope	Crosby G-450 #1010051 or comparable	12



Roadside Safety and
Physical Security Division -
Proving Ground

Project 467823-2b Ground Mounted Timber Support 2013-06-06
 Drawn By GES Scale 1:50 Sheet 2 of 5 Parts

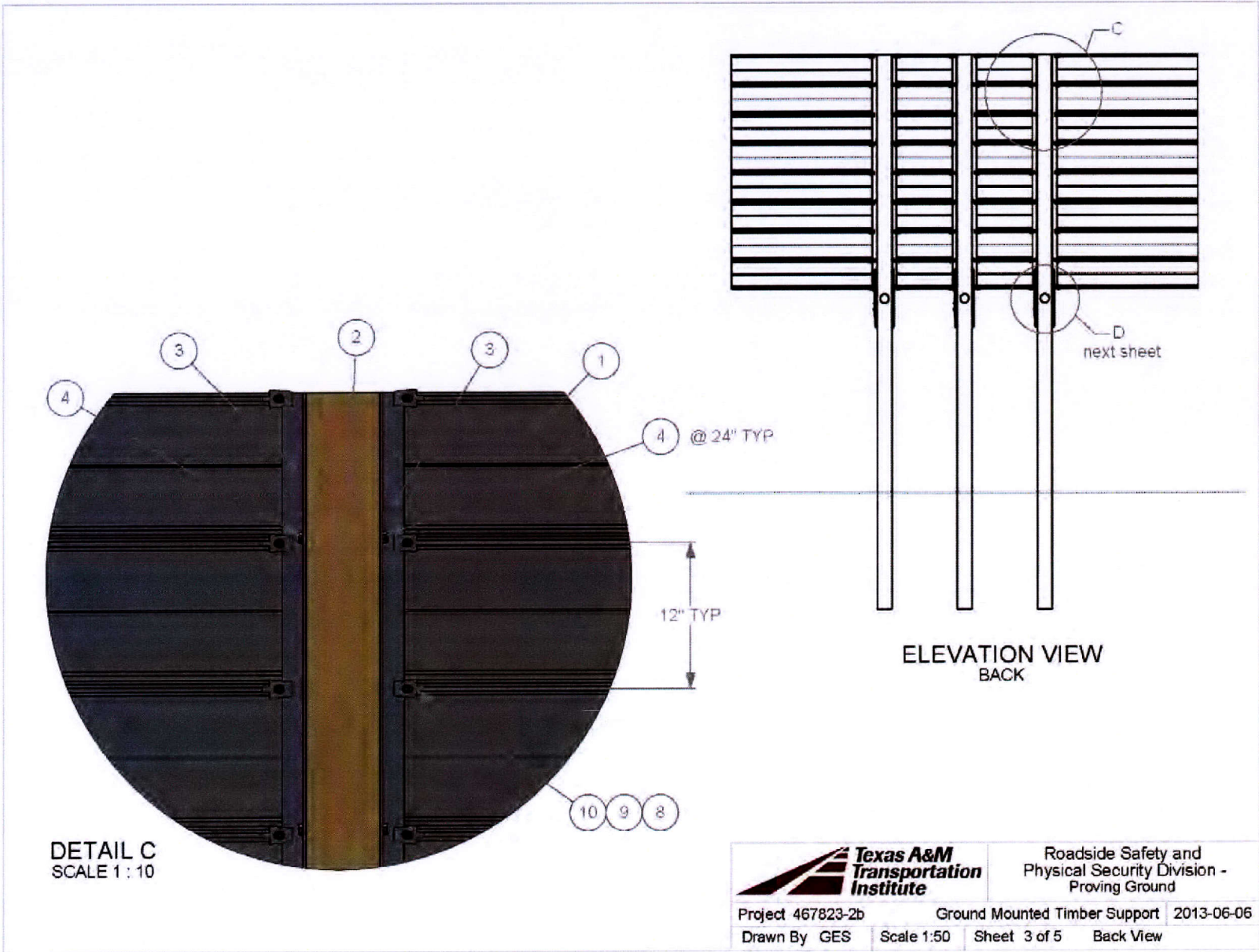

Roadside Safety and
Physical Security Division -
Proving Ground

Project 467823-2b	Ground Mounted Timber Support	2013-06-06
Drawn By GES	Scale 1:50	Sheet 3 of 5 Back View

T:\2012-2013\467823-Tx\DOT Temp Sign Support\467823-2b\Drafting\467823-2b Drawing

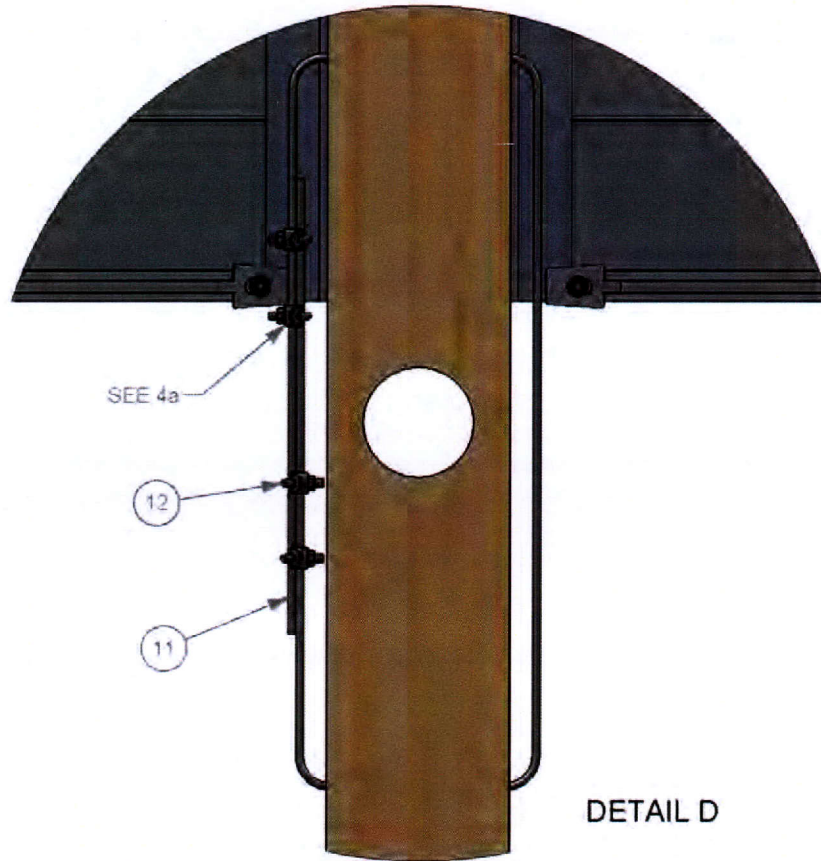

SEE 4a

12

11

DETAIL D

4a. Place cable clamps, 4 at each post, with the U-bolt portion of the clamps on the dead end of the cable and the saddle portions on the live end, as shown. Follow manufacturer's instructions.



Roadside Safety and
Physical Security Division -
Proving Ground

Project 467823-2b	Ground Mounted Timber Support	2013-06-06
Drawn By GES	Scale 1:5	Sheet 4 of 5 Cable Details

② Timber Post

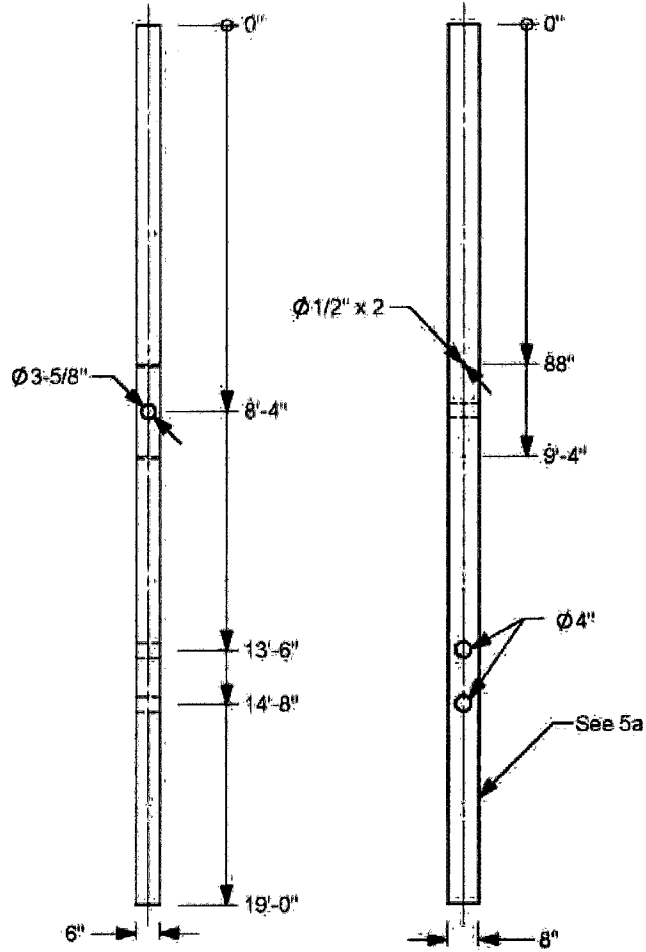

5a. Timber Post is rough-cut treated #1 yellow pine.

③ Angle Stiffener

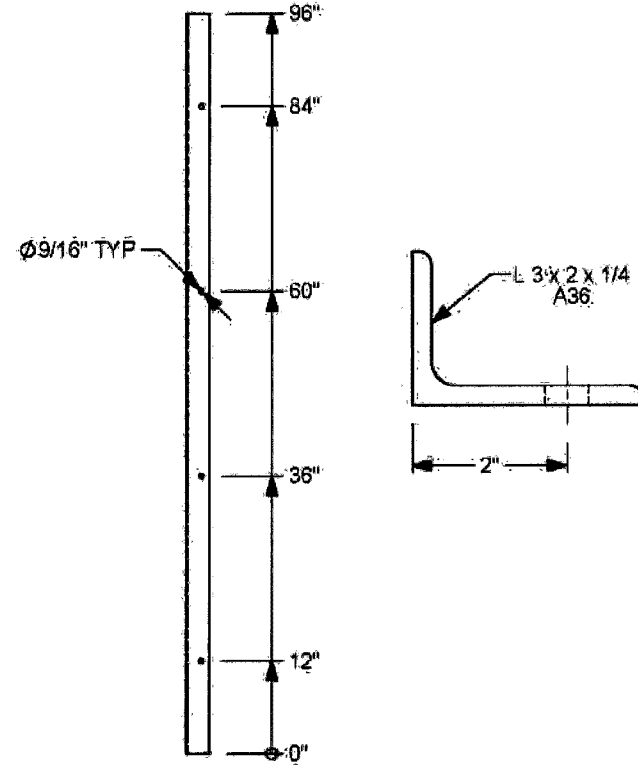

		Roadside Safety and Physical Security Division - Proving Ground	
Project: 467823-2b	Ground Mounted Timber Support	2013-06-06	
Drawn By: GES	Scale: 1:40	Sheet 5 of 5	Post and Stiffener Details

APPENDIX E. CRASH TEST NO. 467823-2B

E.1 TEST VEHICLE PROPERTIES AND INFORMATION

Table E1. Vehicle Properties for Test No. 467823-2b.

Date: 2013-06-13 Test No.: 467823-2b VIN No.: KNADE123666131498
 Year: 2006 Make: Kia Model: Rio
 Tire Inflation Pressure: 32 psi Odometer: 48253 Tire Size: P175/70R14

Describe any damage to the vehicle prior to test: _____

• Denotes accelerometer location.

NOTES: _____

Engine Type: 4 cylinder
 Engine CID: 1.6 liter
 Transmission Type:
 Auto or Manual
 FWD RWD 4WD
 Optional Equipment:
 None

Dummy Data:
 Type: 50th percentile male
 Mass: 179 lb
 Seat Position: Driver

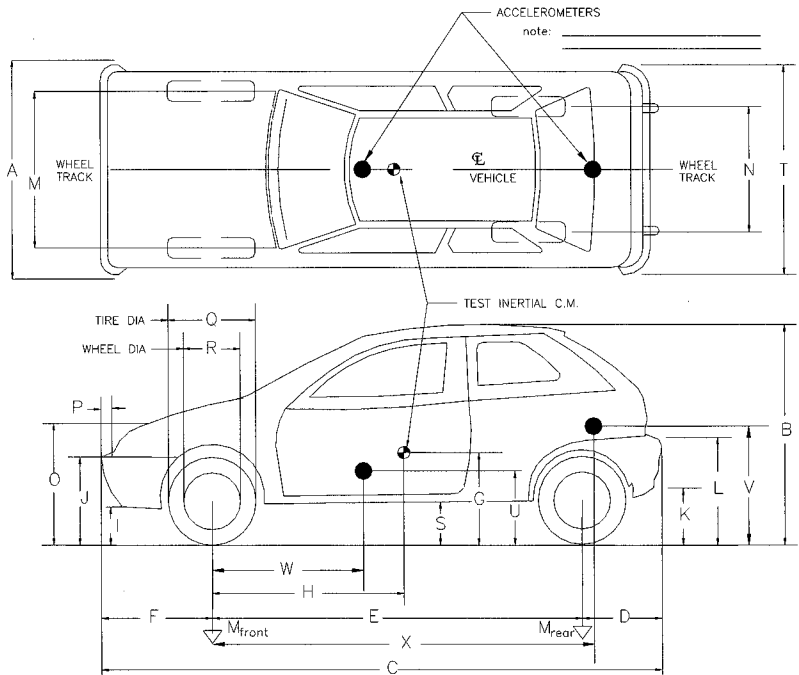

Geometry: inches

A	<u>66.38</u>	F	<u>33.00</u>	K	<u>11.00</u>	P	<u>4.12</u>	U	<u>14.00</u>
B	<u>57.75</u>	G	<u>----</u>	L	<u>24.12</u>	Q	<u>22.18</u>	V	<u>22.00</u>
C	<u>165.75</u>	H	<u>39.21</u>	M	<u>57.75</u>	R	<u>15.38</u>	W	<u>43.00</u>
D	<u>34.00</u>	I	<u>7.12</u>	N	<u>57.12</u>	S	<u>7.62</u>	X	<u>104.00</u>
E	<u>98.75</u>	J	<u>21.00</u>	O	<u>30.62</u>	T	<u>66.12</u>		

Wheel Center Ht Front 11.00 Wheel Center Ht Rear 11.00

GVWR Ratings:	Mass: lb	Curb	Test Inertial	Gross Static
Front <u>1918</u>	M_{front}	<u>1477</u>	<u>1462</u>	<u>1550</u>
Back <u>1874</u>	M_{rear}	<u>876</u>	<u>963</u>	<u>1054</u>
Total <u>3638</u>	M_{Total}	<u>2353</u>	<u>2425</u>	<u>2604</u>

Allowable TIM = 2420 lb ±55 lb | Allowable GSM = 2585 lb ± 55 lb

Mass Distribution:

lb LF: 736 RF: 726 LR: 500 RR: 463

Table E3. Occupant Compartment Measurements for Test No. 467823-2b.

Date: 2013-06-13 Test No.: 467823-2b VIN No.: KNADE123666131498
 Year: 2006 Make: Kia Model: Rio

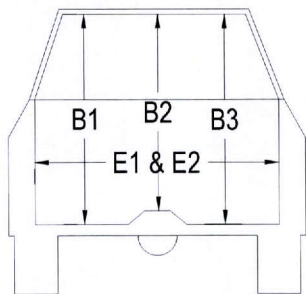
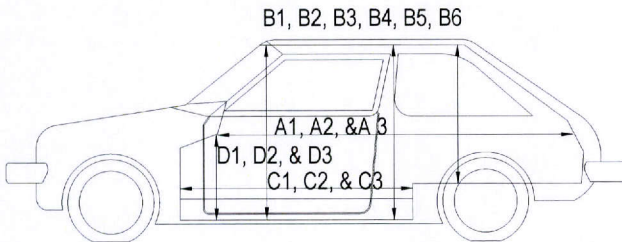
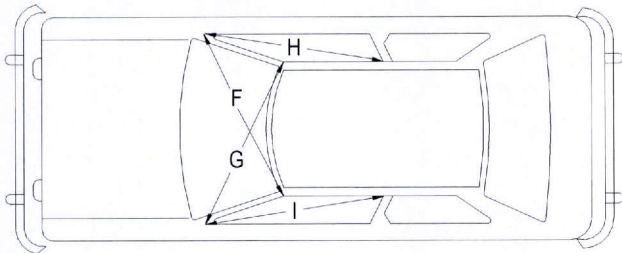

OCCUPANT COMPARTMENT DEFORMATION MEASUREMENT

	Before (inches)	After (inches)
A1	67.50	67.50
A2	67.50	67.50
A3	68.00	68.00
B1	40.25	40.25
B2	36.00	36.00
B3	40.25	40.25
B4	32.12	32.12
B5	32.75	32.75
B6	32.12	32.12
C1	28.00	28.00
C2	----	----
C3	27.50	27.50
D1	10.00	10.00
D2	----	----
D3	9.75	9.75
E1	48.00	48.00
E2	51.00	51.00
F	50.50	50.50
G	50.50	50.50
H	39.00	39.00
I	39.00	39.00
J*	50.75	50.75

*Lateral area across the cab from driver's side kickpanel to passenger's side kickpanel.

E.2 SEQUENTIAL PHOTOGRAPHS



0.000 s



0.040 s



0.080 s



0.120 s



Figure E1. Sequential Photographs for Test No. 467823-2b(Oblique and Perpendicular Views).



0.160 s

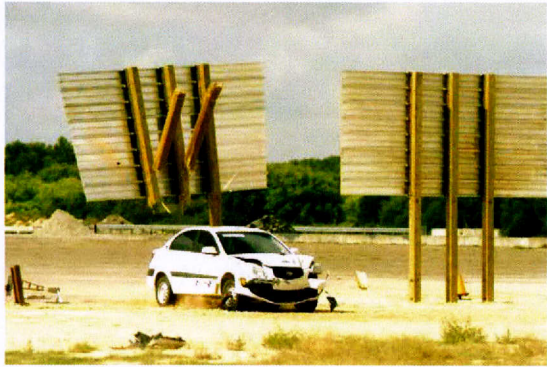

0.200 s

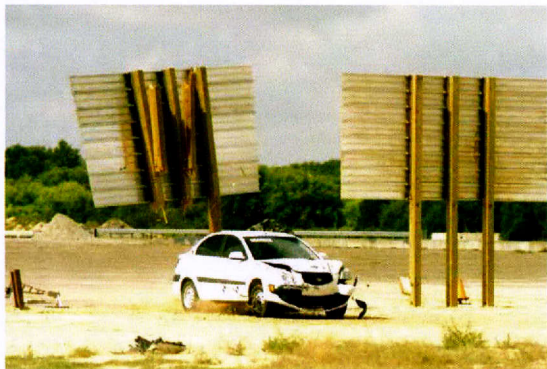

0.240 s

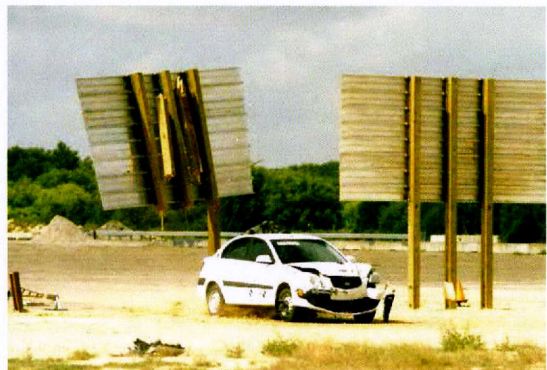

0.280 s



Figure E1. Sequential Photographs for Test No. 467823-2b (Oblique and Perpendicular Views) (Continued).

Roll, Pitch, and Yaw Angles

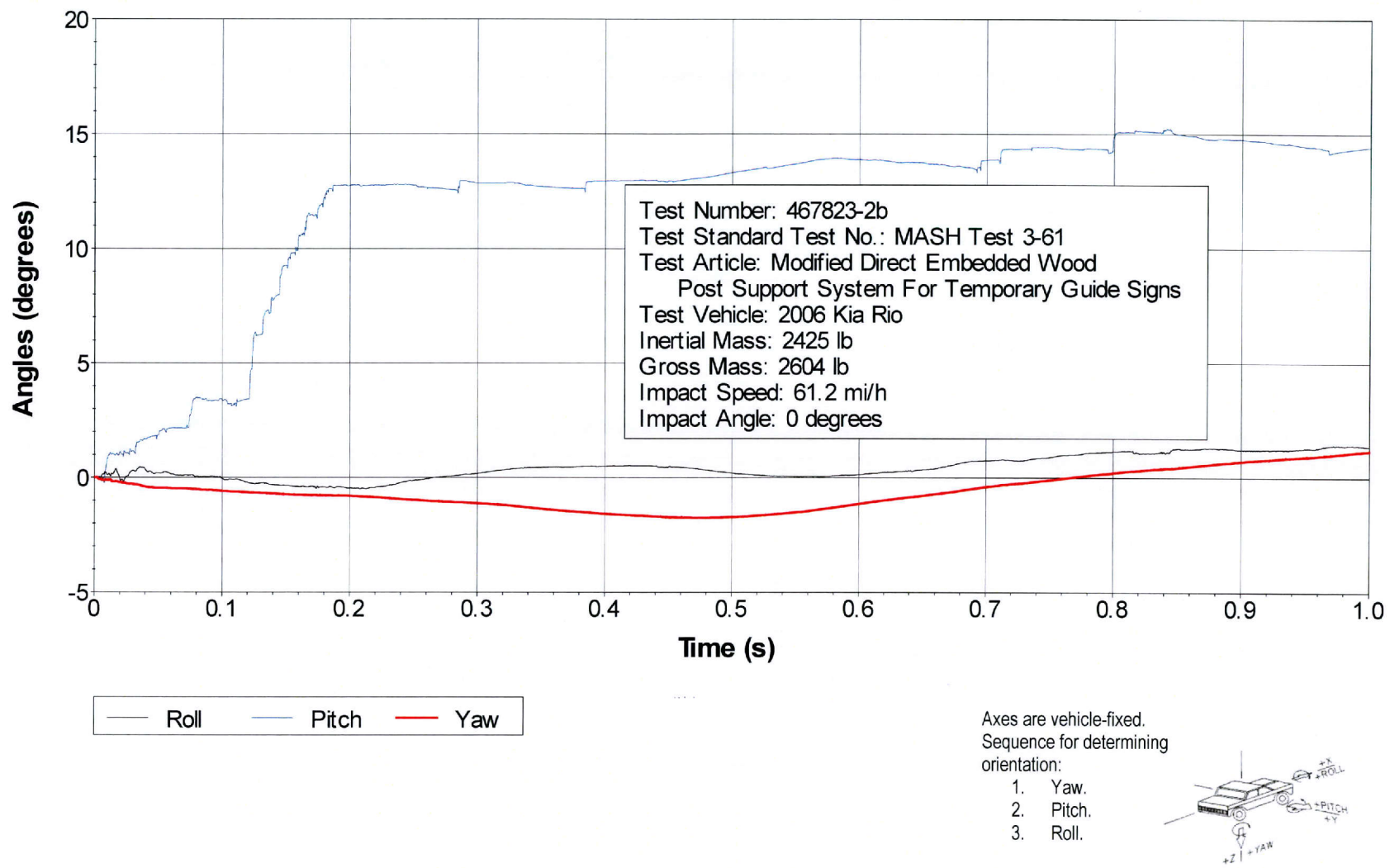
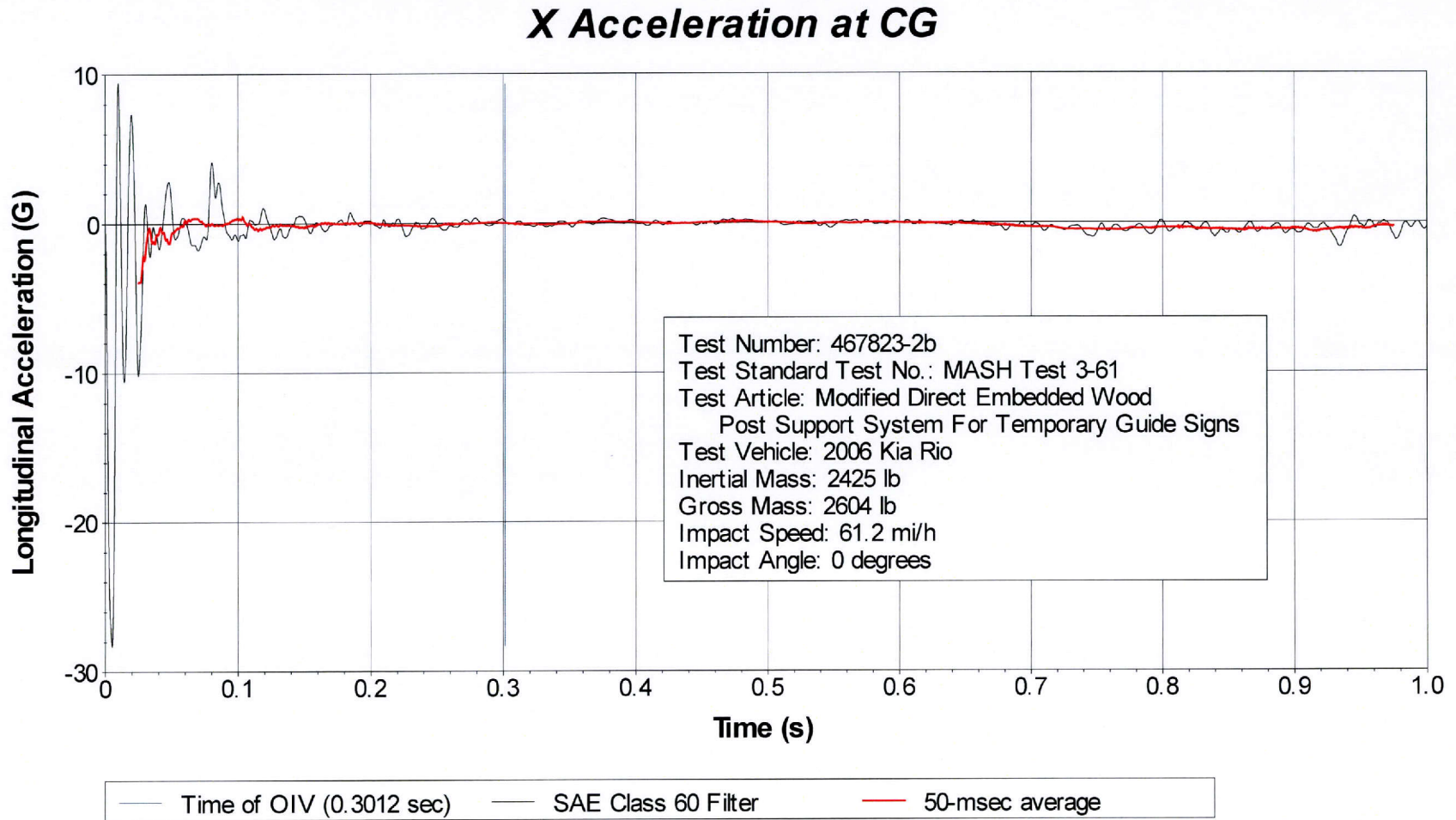

Figure E2. Vehicle Angular Displacements for Test No. 467823-2b.



**Figure E3. Vehicle Longitudinal Accelerometer Trace for Test No. 467823-2b
 (Accelerometer Located at Center of Gravity).**

Y Acceleration at CG

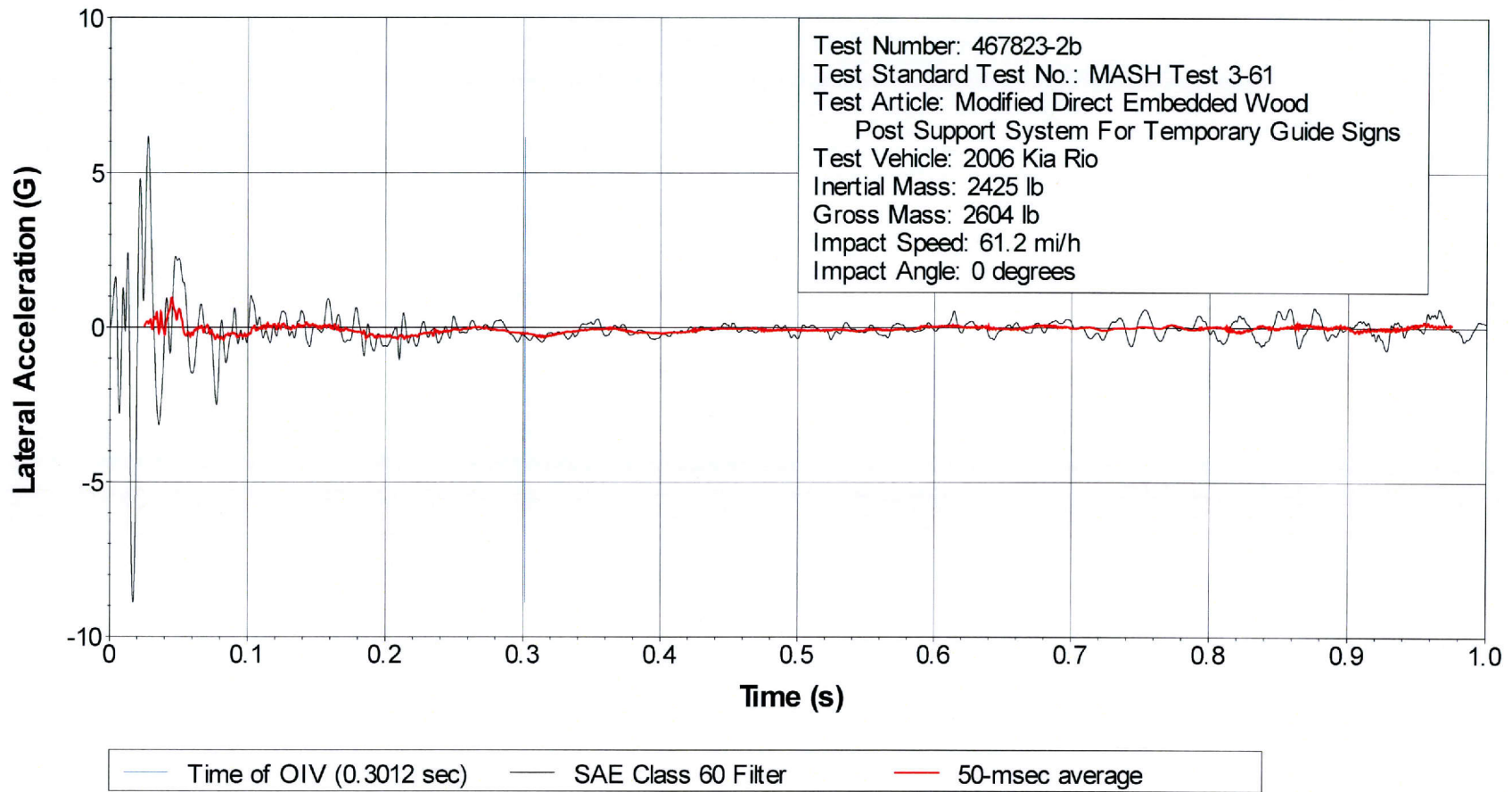
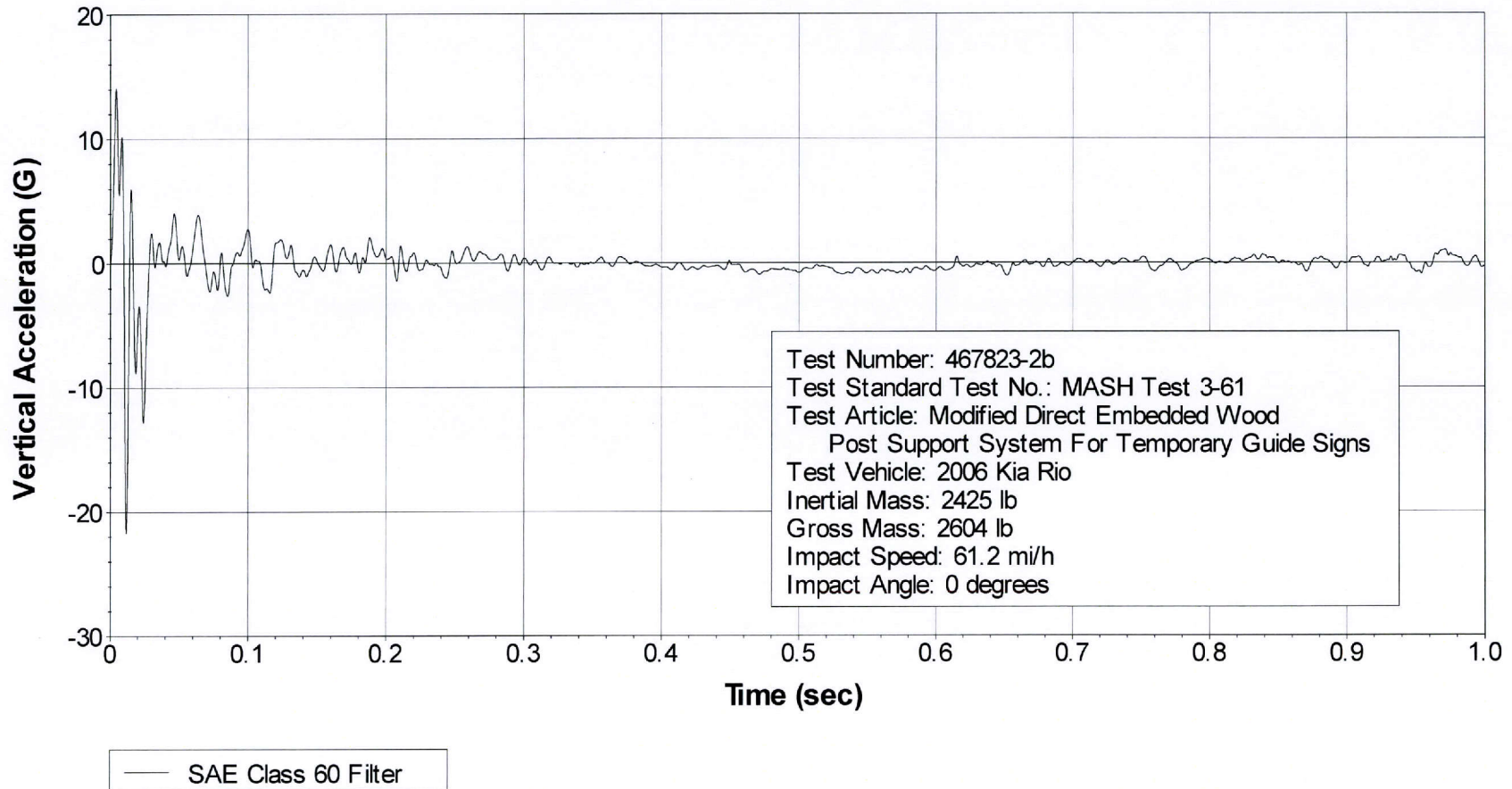

Figure E4. Vehicle Lateral Accelerometer Trace for Test No. 467823-2b (Accelerometer Located at Center of Gravity).

Z Acceleration at CG



**Figure E5. Vehicle Vertical Accelerometer Trace for Test No. 467823-2b
(Accelerometer Located at Center of Gravity).**

X Acceleration Rear of CG

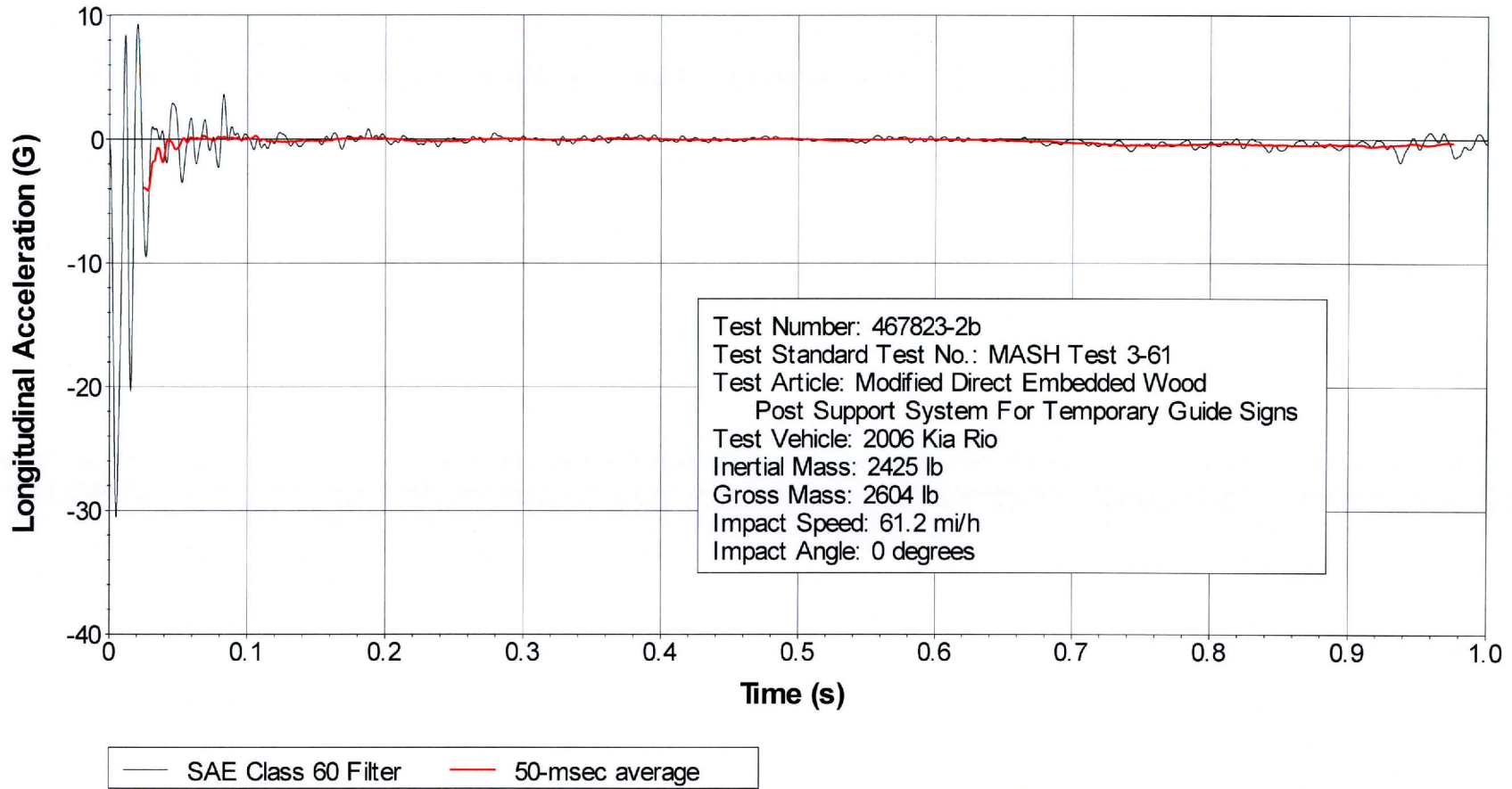
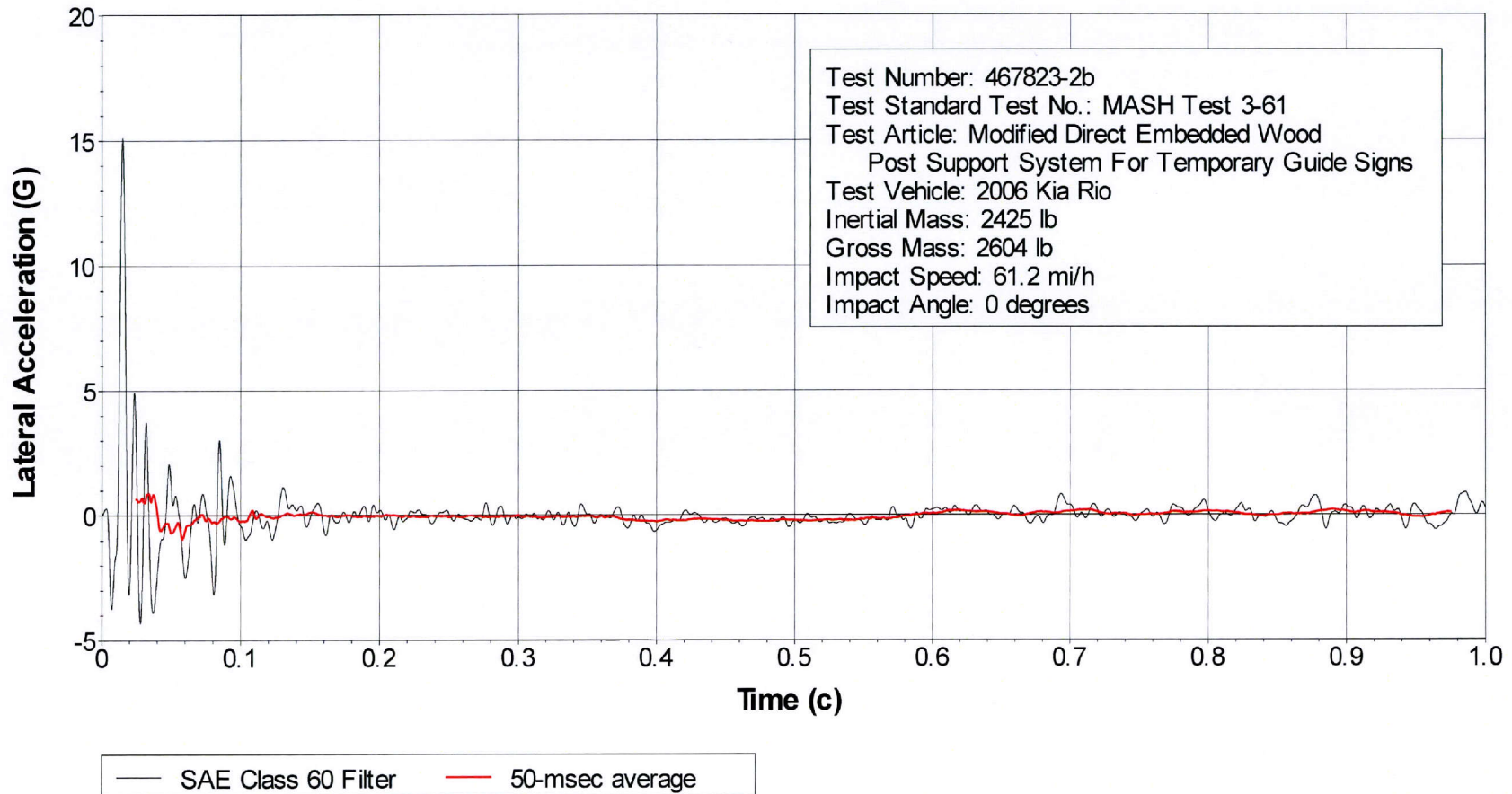

Figure E6. Vehicle Longitudinal Accelerometer Trace for Test No. 467823-2b (Accelerometer Located Rear of Center of Gravity).

Y Acceleration Rear of CG



**Figure E7. Vehicle Lateral Accelerometer Trace for Test No. 467823-2b
 (Accelerometer Located Rear of Center of Gravity).**

Z Acceleration Rear of CG

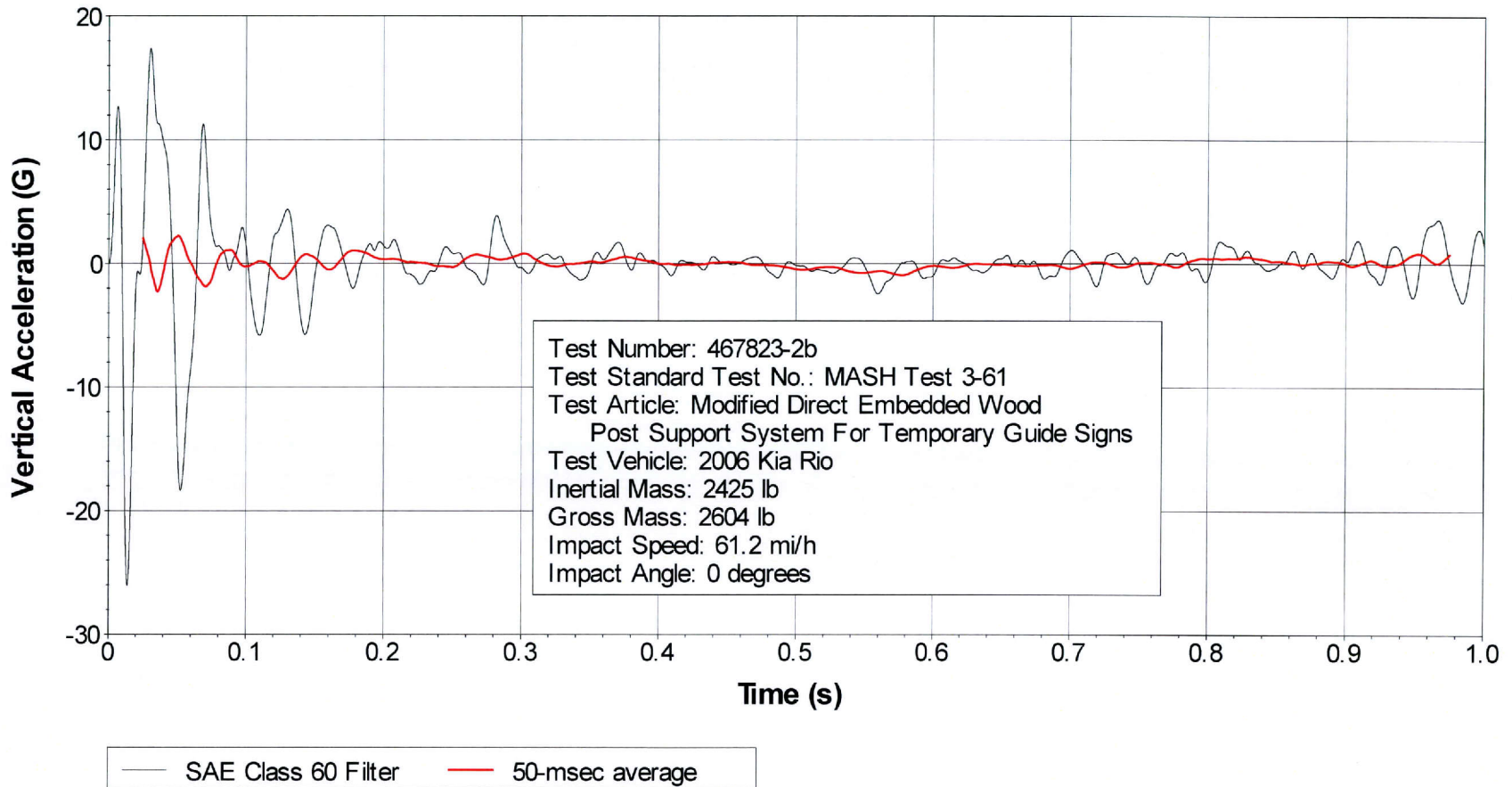

Figure E8. Vehicle Vertical Accelerometer Trace for Test No. 467823-2b (Accelerometer Located Rear of Center of Gravity).

APPENDIX F. CRASH TEST NO. 467823-3

F.1 TEST VEHICLE PROPERTIES AND INFORMATION

Table F1. Vehicle Properties for Test No. 467823-3.

Date: 2013-06-13 Test No.: 467823-3 VIN No.: 1D7HA18075152165
 Year: 2007 Make: Dodge Model: Ram 1500
 Tire Size: 265/70R14 Tire Inflation Pressure: 35 psi
 Tread Type: _____ Odometer: 151363
 Note any damage to the vehicle prior to test: _____

• Denotes accelerometer location.

NOTES: _____

Engine Type: V-8
 Engine CID: 5.7 liter

Transmission Type:
 Auto or _____ Manual
 FWD RWD 4WD

Optional Equipment:
None

Dummy Data:
 Type: No dummy
 Mass: _____
 Seat Position: _____

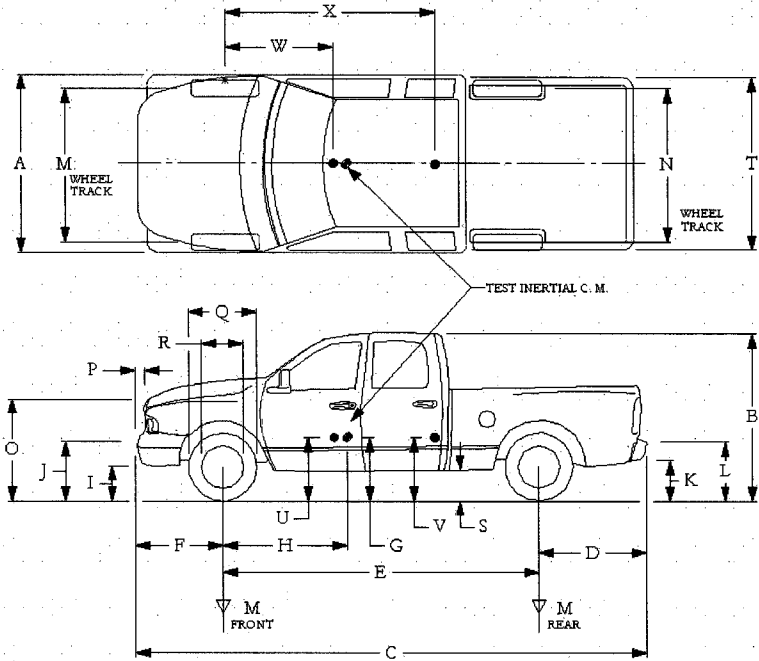

Geometry: inches

A	<u>78.25</u>	F	<u>36.00</u>	K	<u>20.75</u>	P	<u>2.88</u>	U	<u>28.50</u>
B	<u>75.75</u>	G	<u>28.38</u>	L	<u>29.25</u>	Q	<u>30.50</u>	V	<u>30.50</u>
C	<u>223.75</u>	H	<u>60.71</u>	M	<u>68.50</u>	R	<u>18.38</u>	W	<u>60.70</u>
D	<u>47.25</u>	I	<u>15.50</u>	N	<u>68.00</u>	S	<u>16.00</u>	X	<u>75.00</u>
E	<u>140.50</u>	J	<u>28.00</u>	O	<u>46.50</u>	T	<u>77.50</u>		
Wheel Center Height Front	<u>14.75</u>	Wheel Well Clearance (Front)	<u>6.00</u>	Bottom Frame Height - Front	<u>18.75</u>				
Wheel Center Height Rear	<u>14.75</u>	Wheel Well Clearance (Rear)	<u>11.25</u>	Bottom Frame Height - Rear	<u>26.00</u>				

GVWR Ratings:	Mass: lb	Curb	Test Inertial	Gross Static
Front	<u>3700</u>	M_{front}	<u>2908</u>	<u>2848</u>
Back	<u>3900</u>	M_{rear}	<u>2107</u>	<u>2167</u>
Total	<u>6700</u>	M_{Total}	<u>5015</u>	<u>5015</u>

Mass Distribution:
 lb LF: 1446 RF: 1402 LR: 1065 RR: 1102

Table F2. Vehicle Parametric Measurement for Vertical CG for Test No. 467823-3.

Date: 2013-06-13 Test No.: 467823-3 VIN: 1D7HA18075152165
 Year: 2007 Make: Dodge Model: Ram 1500
 Body Style: Quad Cab Mileage: 151363
 Engine: V-8 4.7 liter Transmission: Automatic
 Fuel Level: Empty Ballast: 40 lb in front of bed (440 lb max)
 Tire Pressure: Front: 35 psi Rear: 35 psi Size: 265/70R17

Measured Vehicle Weights: (lb)			
LF:	1446	RF:	1402
Front Axle:		2848	
LR:	1065	RR:	1102
Rear Axle:		2167	
Left:	2511	Right:	2504
Total:		5015	
5000 ±110 lb allowed			
Wheel Base:	140.5 inches	Track: F:	68.5 inches
	148 ±12 inches allowed	R:	68 inches
Track = (F+R)/2 = 67 ±1.5 inches allowed			
Center of Gravity, SAE J874 Suspension Method			
X:	60.71 in	Rear of Front Axle	(63 ±4 inches allowed)
Y:	-0.05 in	Left - Right +	of Vehicle Centerline
Z:	28.375 in	Above Ground	(mininum 28.0 inches allowed)

Hood Height: 46.50 inches Front Bumper Height: 28.00 inches
 43 ±4 inches allowed

Front Overhang: 36.00 inches Rear Bumper Height: 29.25 inches
 39 ±3 inches allowed

Overall Length: 223.75 inches
 237 ±13 inches allowed

Table F3. Vehicle Exterior Crush Measurements for Test No. 467823-3.

Date: 2013-06-13 Test No.: 467823-3 VIN No.: 1D7HA18075152165
 Year: 2007 Make: Dodge Model: Ram 1500

VEHICLE CRUSH MEASUREMENT SHEET¹

Complete When Applicable	
End Damage	Side Damage
Undeformed end width _____ Corner shift: A1 _____ A2 _____ End shift at frame (CDC) (check one) < 4 inches _____ ≥ 4 inches _____	Bowing: B1 _____ X1 _____ B2 _____ X2 _____ Bowing constant $\frac{X1 + X2}{2} = \underline{\hspace{2cm}}$

Note: Measure C₁ to C₆ from Driver to Passenger side in Front or Rear impacts – Rear to Front in Side Impacts.

Specific Impact Number	Plane* of C-Measurements	Direct Damage		Field L**	C ₁	C ₂	C ₃	C ₄	C ₅	C ₆	±D
		Width** (CDC)	Max*** Crush								
1	Front plane at bumper ht	----	1.0	----	----	1.0	----	----	----	1.0	0
	Measurements recorded										
	in inches										

¹Table taken from National Accident Sampling System (NASS).

*Identify the plane at which the C-measurements are taken (e.g., at bumper, above bumper, at sill, above sill, at beltline, etc.) or label adjustments (e.g., free space).

Free space value is defined as the distance between the baseline and the original body contour taken at the individual C locations. This may include the following: bumper lead, bumper taper, side protrusion, side taper, etc. Record the value for each C-measurement and maximum crush.

**Measure and document on the vehicle diagram the beginning or end of the direct damage width and field L (e.g., side damage with respect to undamaged axle).

***Measure and document on the vehicle diagram the location of the maximum crush.

Note: Use as many lines/columns as necessary to describe each damage profile.

Table F4. Occupant Compartment Measurements for Test No. 467823-3.

Date: 2013-06-13 Test No.: 467823-3 VIN No.: 1D7HA18075152165
 Year: 2007 Make: Dodge Model: Ram 1500

OCCUPANT COMPARTMENT DEFORMATION MEASUREMENT

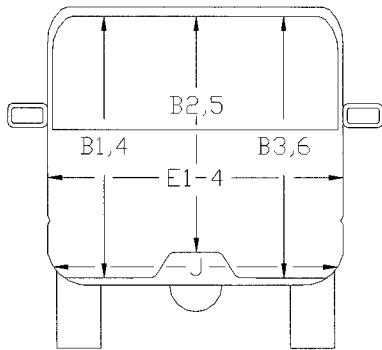
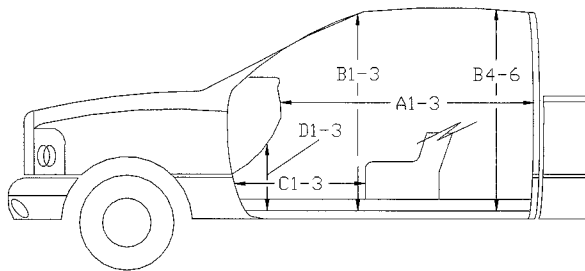
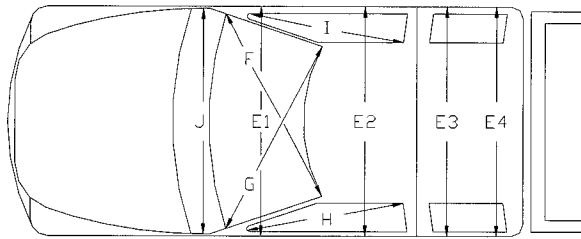

	Before (inches)	After (inches)
A1	64.50	64.50
A2	64.75	64.75
A3	65.00	65.00
B1	45.50	45.50
B2	39.25	39.25
B3	45.50	45.50
B4	42.00	42.00
B5	45.00	45.00
B6	42.00	42.00
C1	29.50	29.50
C2	----	----
C3	27.00	27.00
D1	12.50	12.50
D2	----	----
D3	11.50	11.50
E1	62.75	62.75
E2	64.50	64.50
E3	63.75	63.75
E4	64.25	64.25
F	60.00	60.00
G	60.00	60.00
H	39.00	39.00
I	39.00	39.00
J*	62.25	62.25

*Lateral area across the cab from driver's side kickpanel to passenger's side kickpanel.

F.2 SEQUENTIAL PHOTOGRAPHS

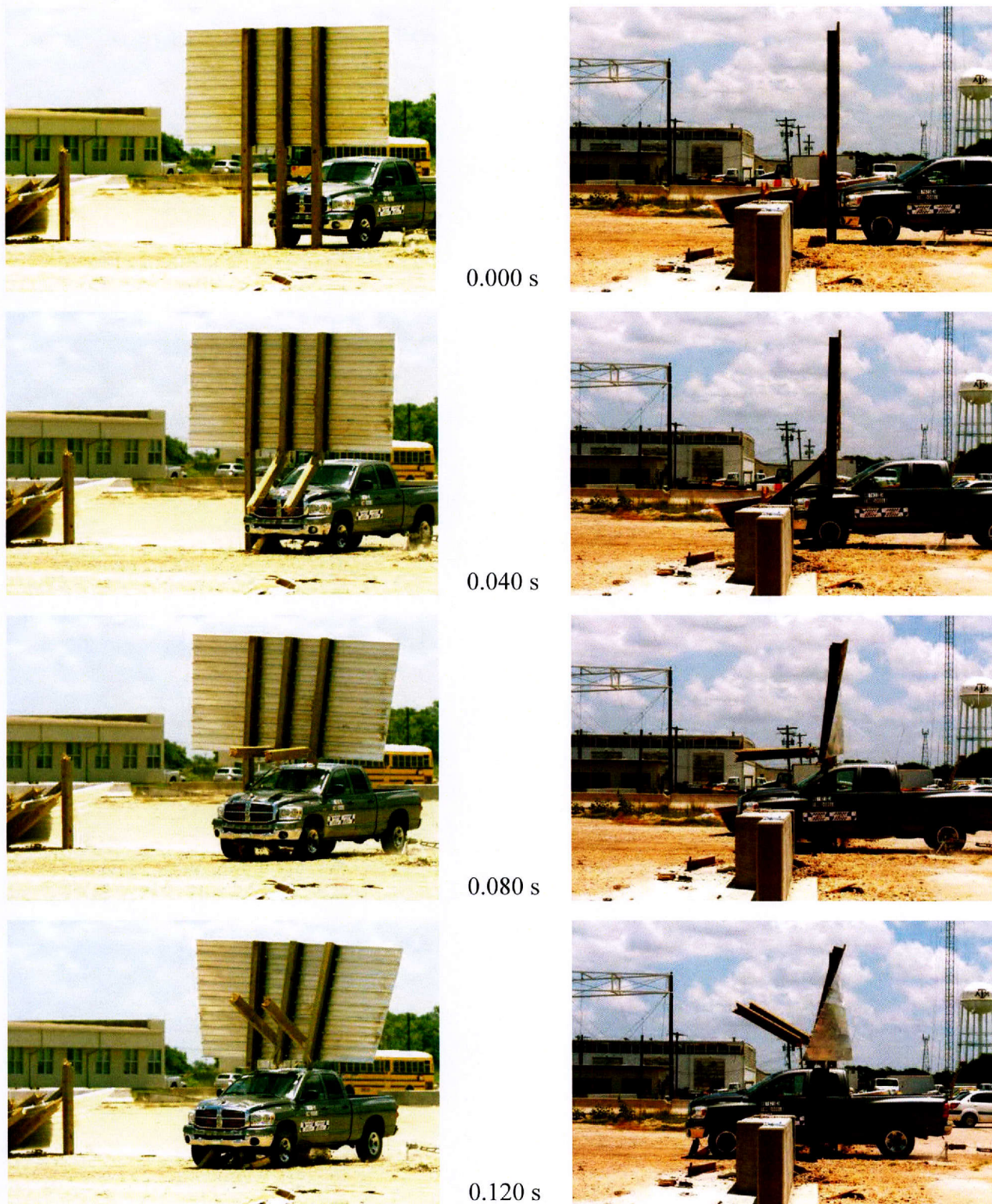

Figure F1. Sequential Photographs for Test No. 467823-3(Oblique and Perpendicular Views).



0.160 s



0.200 s



0.240 s



0.280 s



**Figure F1. Sequential Photographs for Test No. 467823-3
(Oblique and Perpendicular Views) (Continued).**

Roll, Pitch, and Yaw Angles

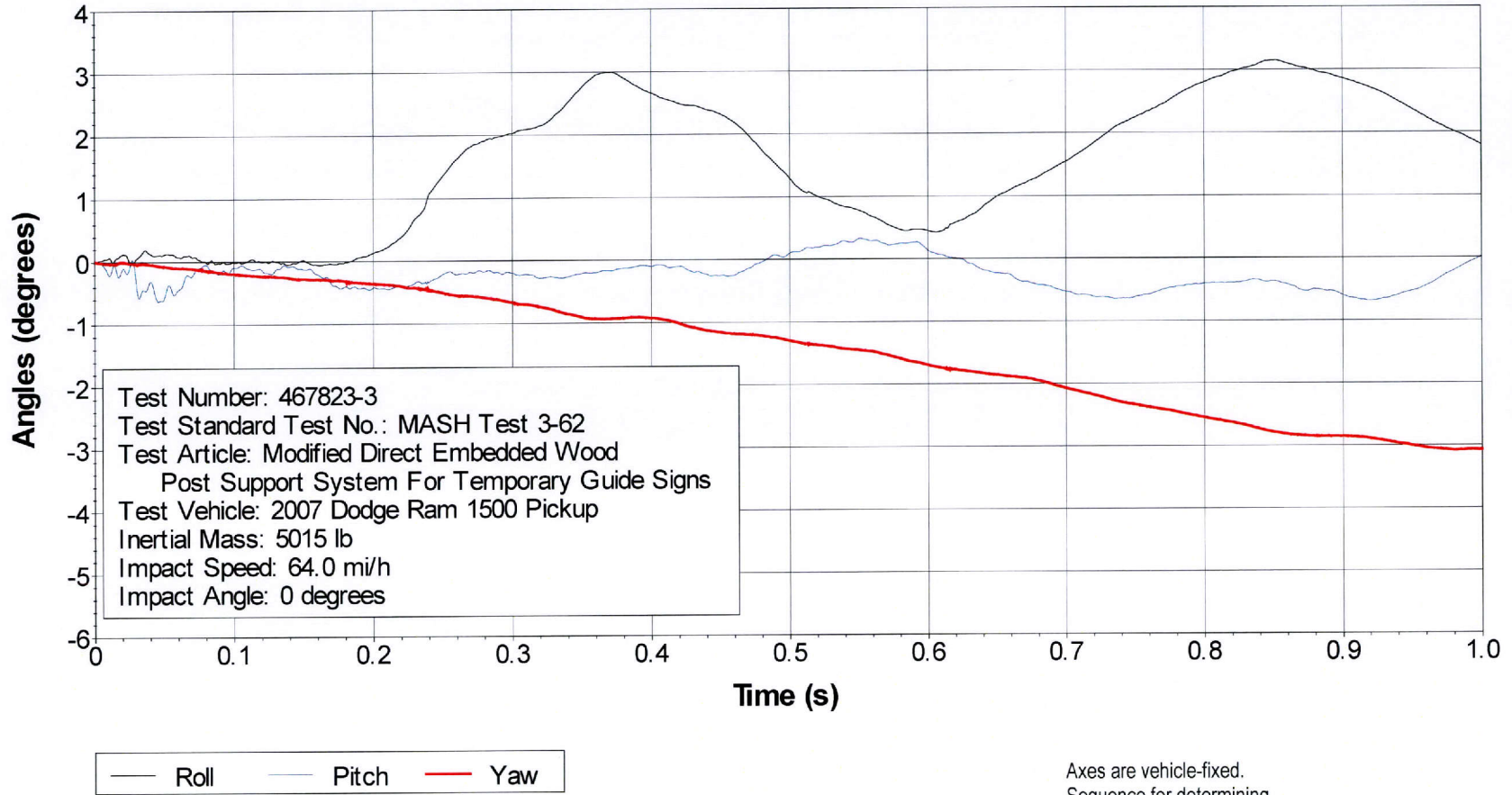

Axes are vehicle-fixed.
Sequence for determining orientation:

1. Yaw.
2. Pitch.
3. Roll.

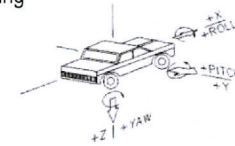

Figure F2. Vehicle Angular Displacements for Test No. 467823-3.

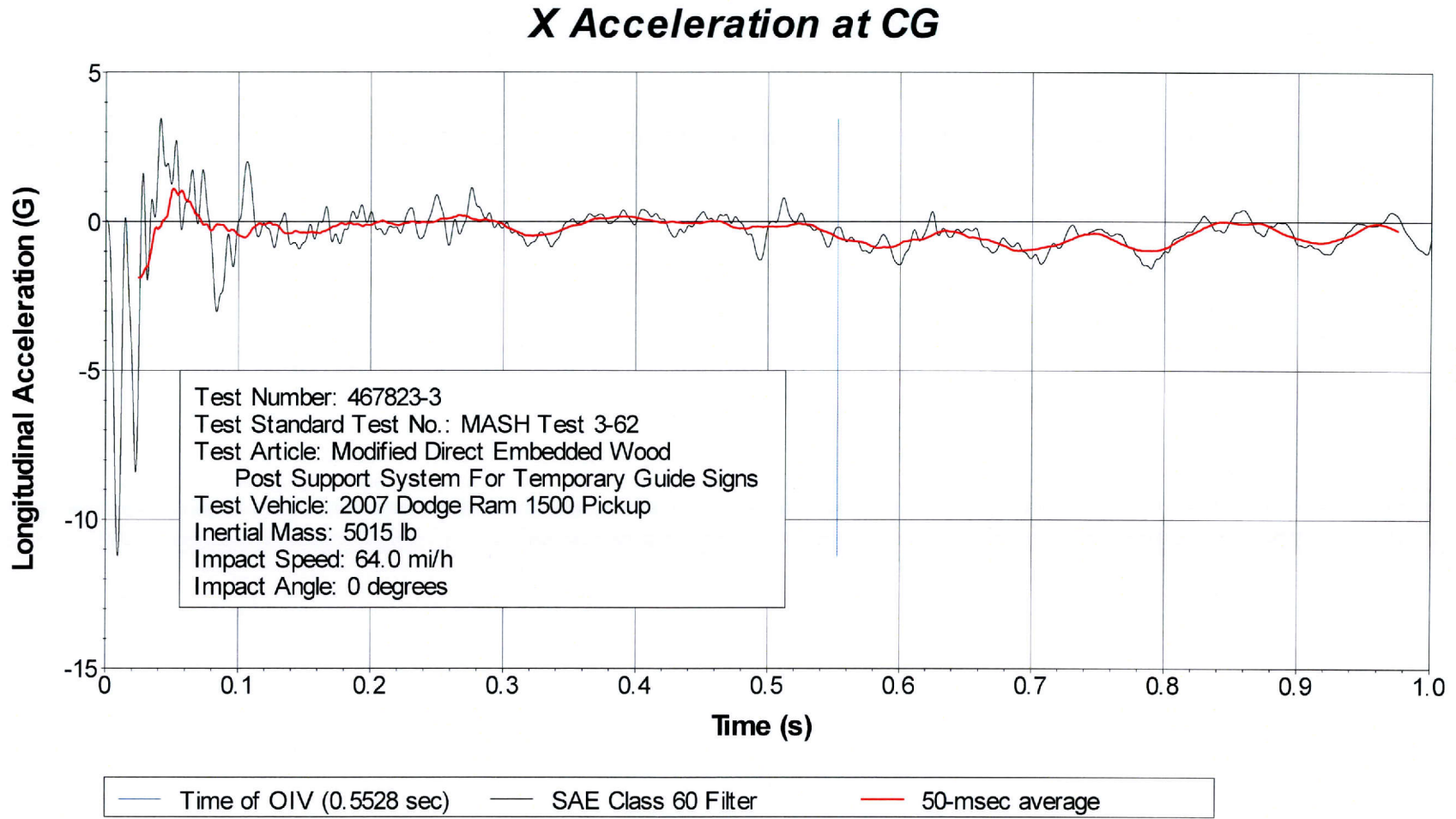

Figure F3. Vehicle Longitudinal Accelerometer Trace for Test No. 467823-3 (Accelerometer Located at Center of Gravity).

Y Acceleration at CG

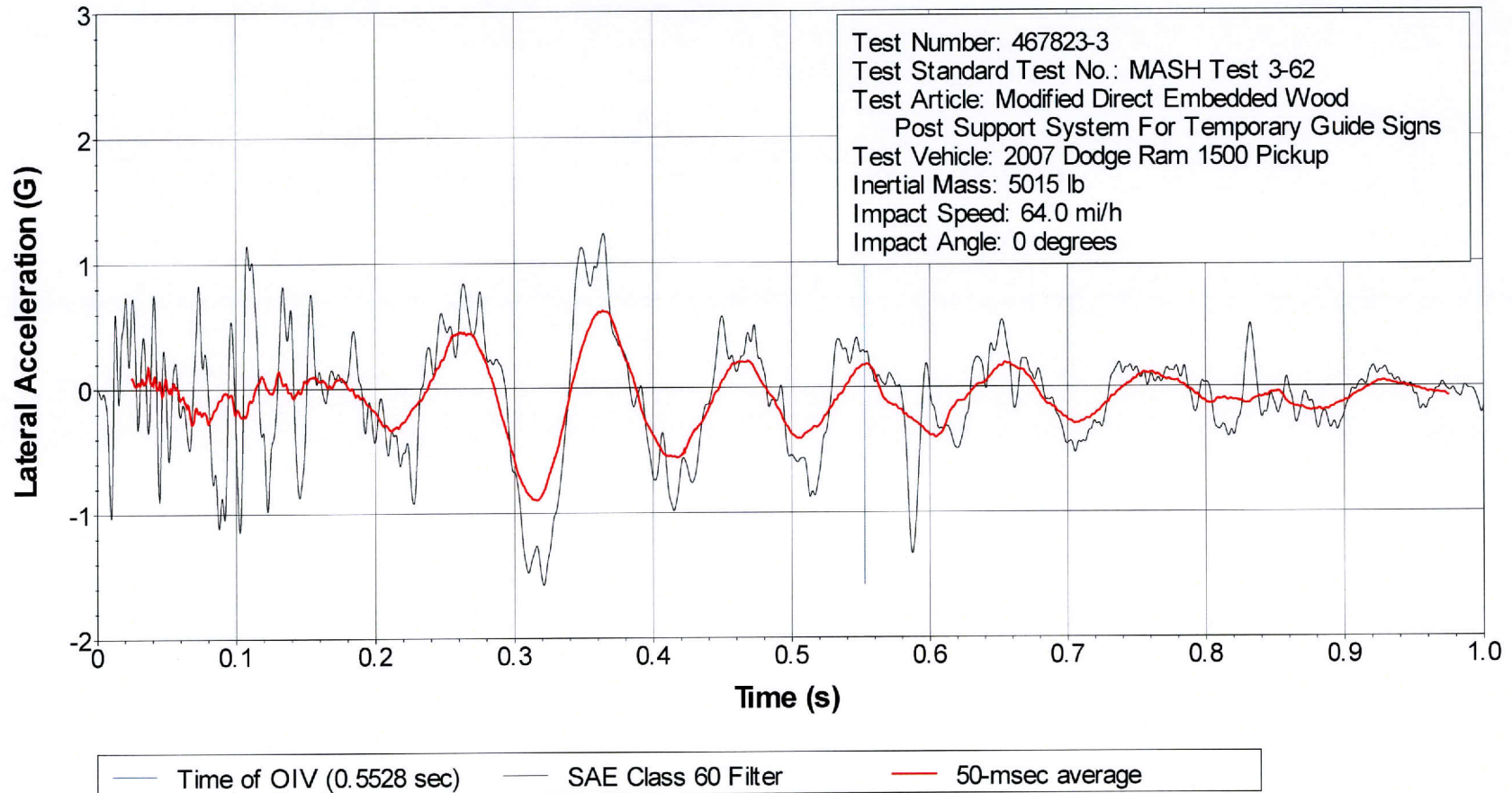

Figure F4. Vehicle Lateral Accelerometer Trace for Test No. 467823-3 (Accelerometer Located at Center of Gravity).

Z Acceleration at CG

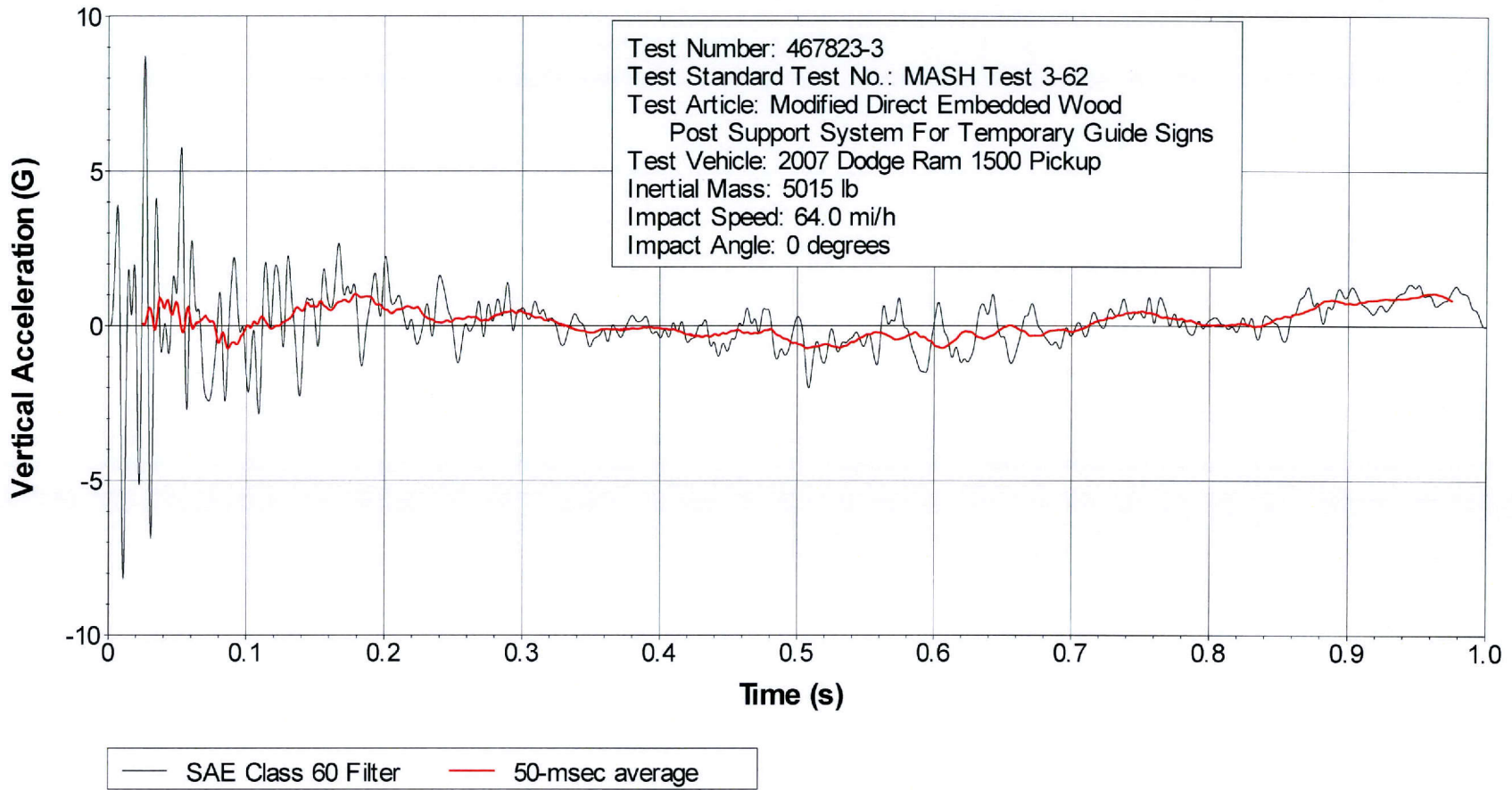

Figure F5. Vehicle Vertical Accelerometer Trace for Test No. 467823-3 (Accelerometer Located at Center of Gravity).

X Acceleration Rear of CG

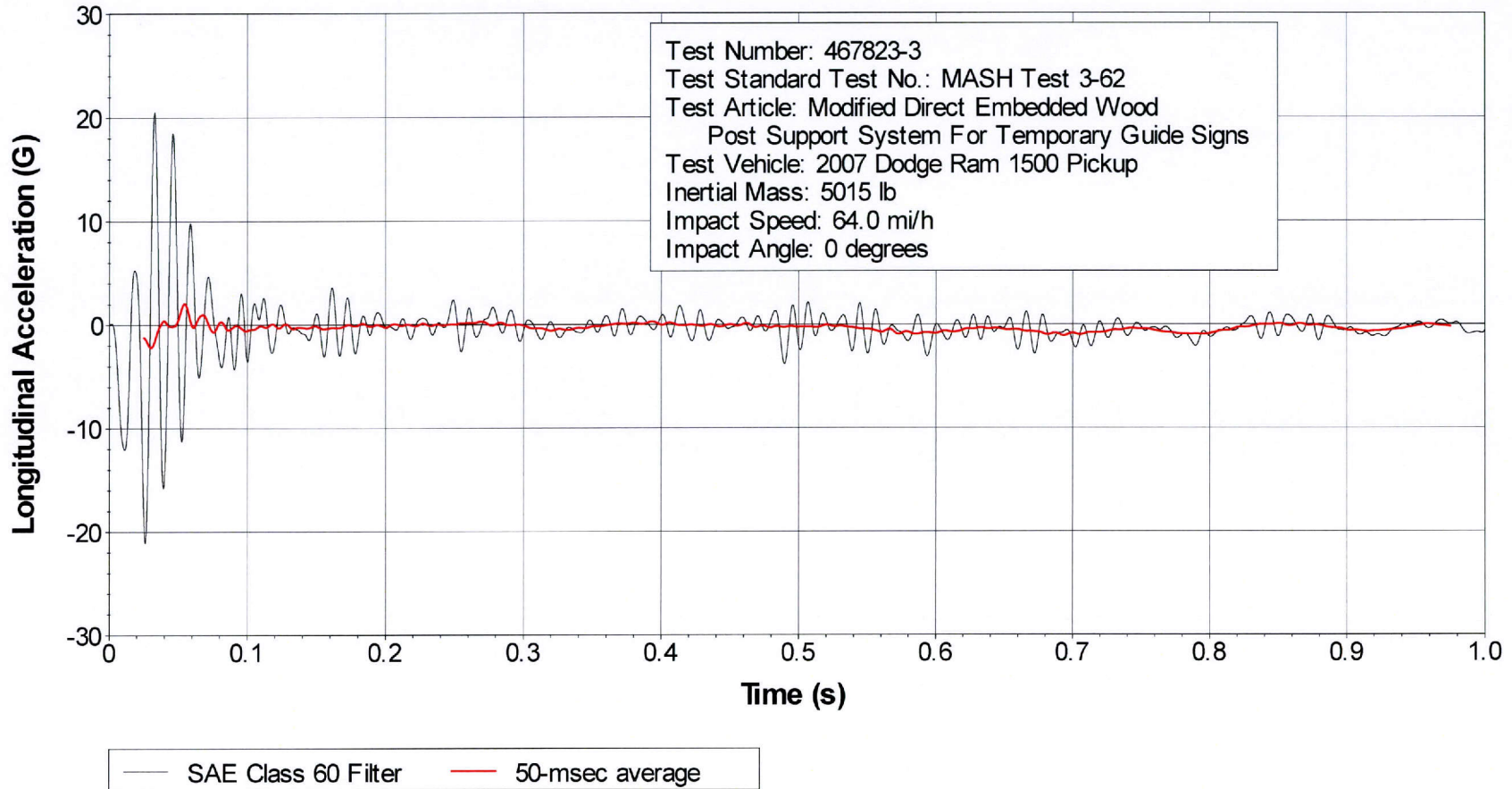

Figure F6. Vehicle Longitudinal Accelerometer Trace for Test No. 467823-3 (Accelerometer Located Rear of Center of Gravity).

Y Acceleration Rear of CG

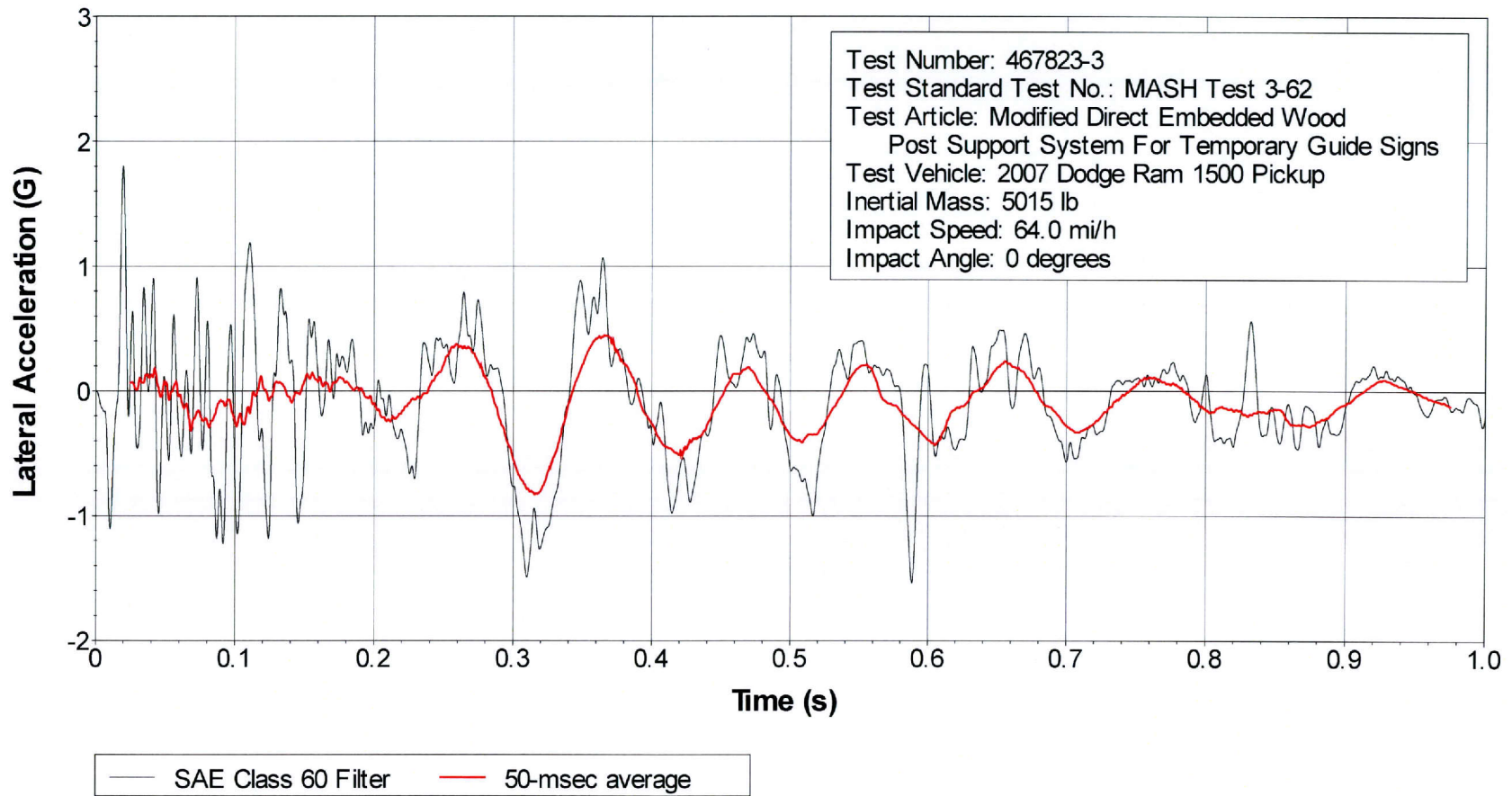

Figure F7. Vehicle Lateral Accelerometer Trace for Test No. 467823-3 (Accelerometer Located Rear of Center of Gravity).

Z Acceleration Rear of CG

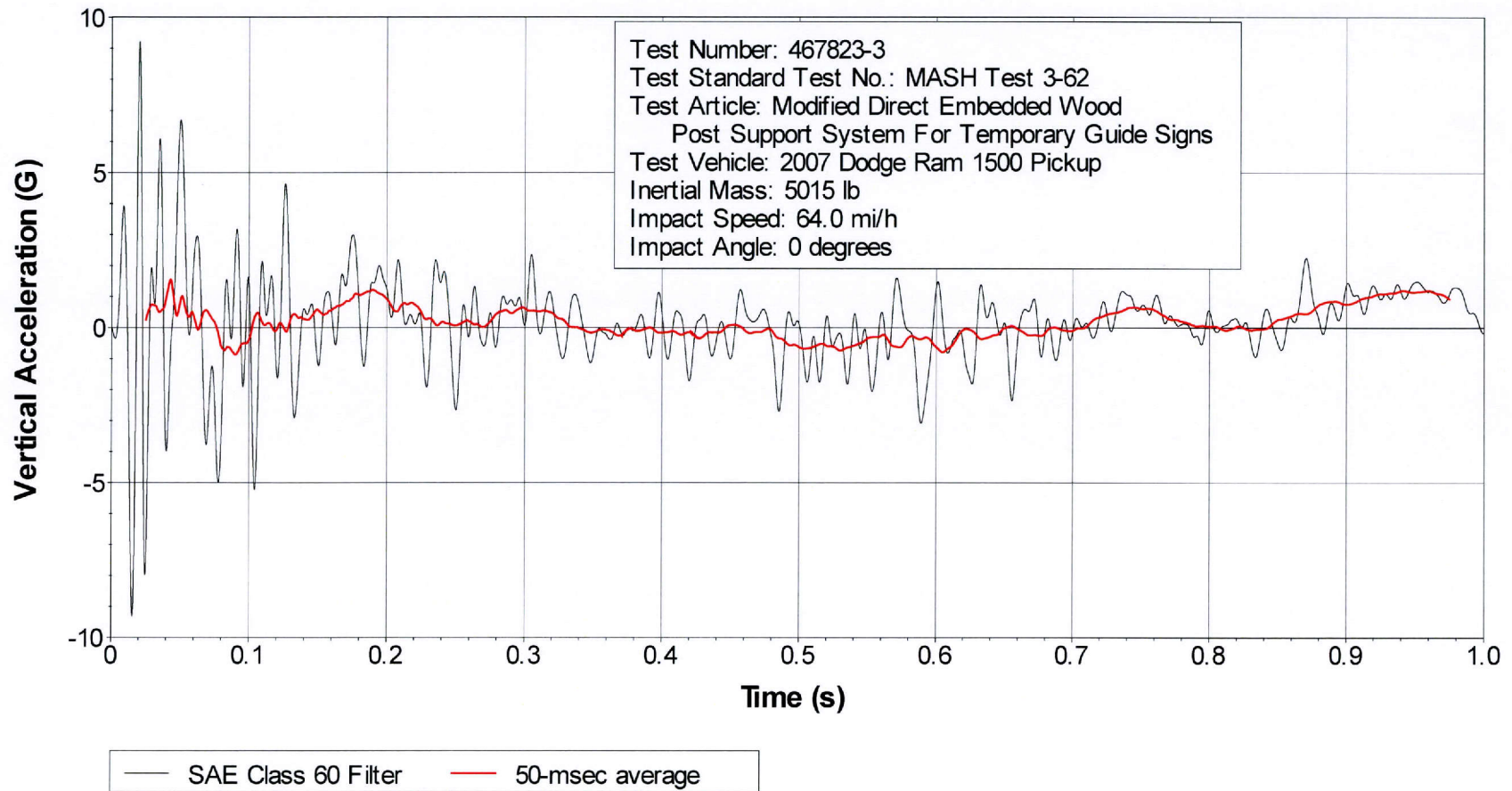
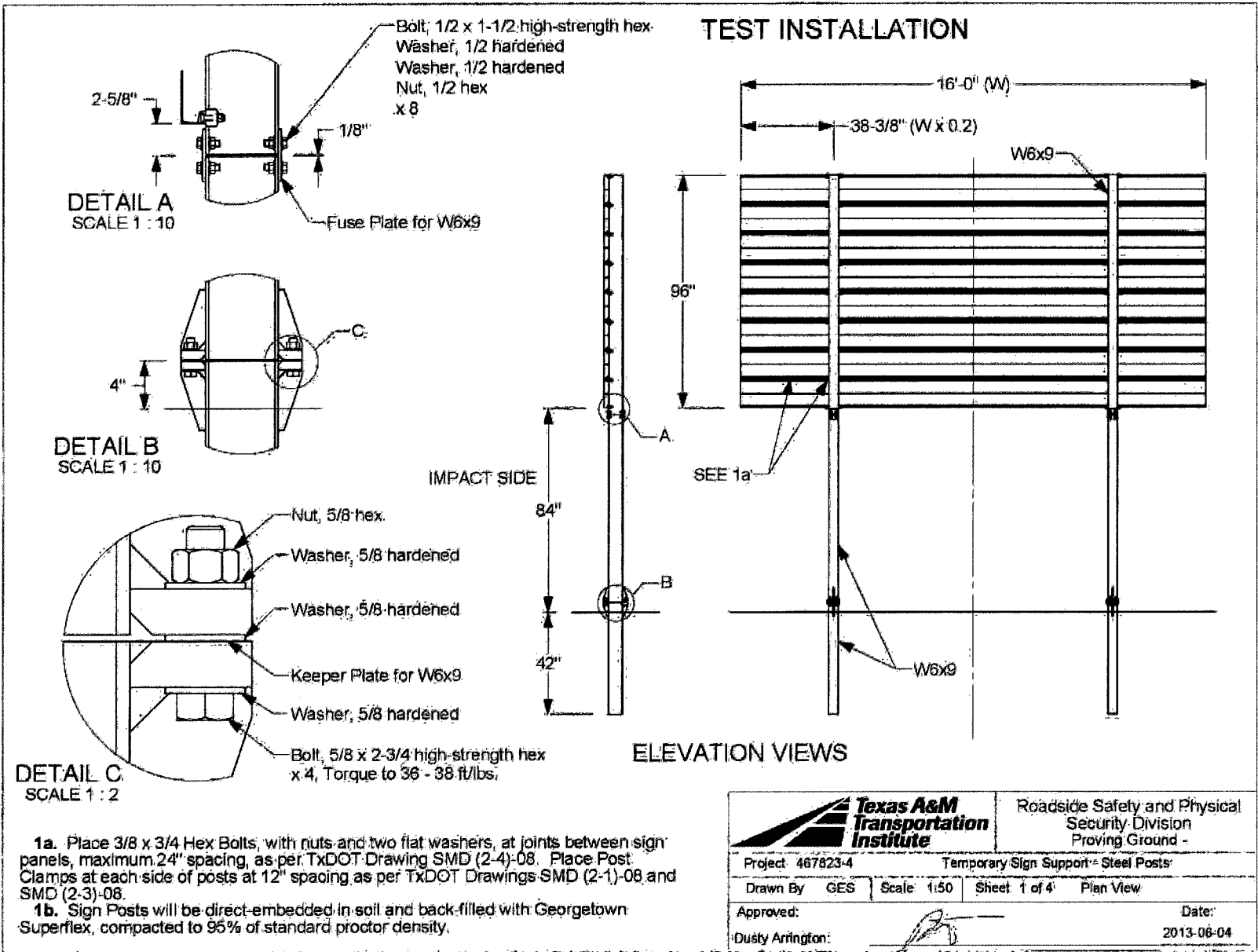

Figure F8. Vehicle Vertical Accelerometer Trace for Test No. 467823-3 (Accelerometer Located Rear of Center of Gravity).

**APPENDIX G. DETAILS OF THE MODIFIED DIRECT EMBEDDED
STEEL SUPPORT TEMPORARY GUIDE SIGN SYSTEM**

Drawing: 467823-4 Drawing: 467823-4 Drawing: 467823-4 Drawing: 467823-4 Drawing: 467823-4



- 1a.** Place 3/8 x 3/4 Hex Bolts, with nuts and two flat washers, at joints between sign panels, maximum 24" spacing, as per TxDOT Drawing SMD (2-4)-08. Place Post Clamps at each side of posts at 12" spacing as per TxDOT Drawings SMD (2-1)-08 and SMD (2-3)-08.
- 1b.** Sign Posts will be direct-embedded in soil and back-filled with Georgetown Superflex, compacted to 95% of standard proctor density.

		Roadside Safety and Physical Security Division	
		Proving Ground -	
Project: 467823-4		Temporary Sign Support - Steel Posts	
Drawn By: GES	Scale: 1:50	Sheet: 1 of 4	Plan View
Approved:		Date: 2013-06-04	
Dusty Arrington: _____			

POST SECTION, MIDDLE

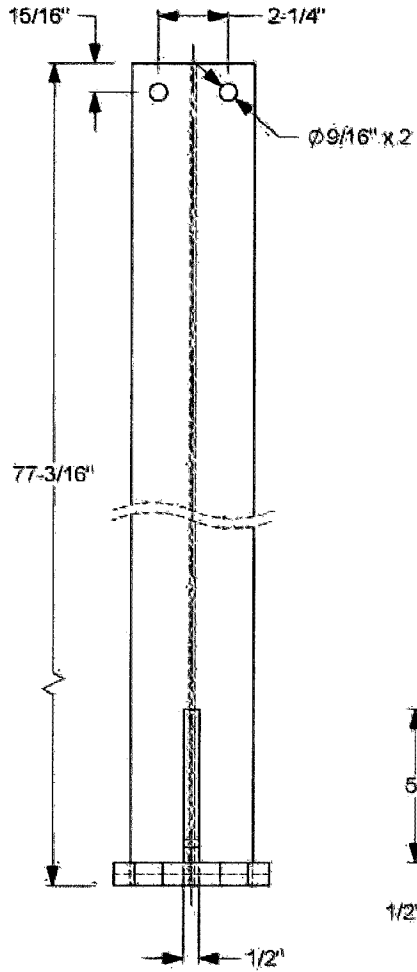

ELEVATION VIEWS

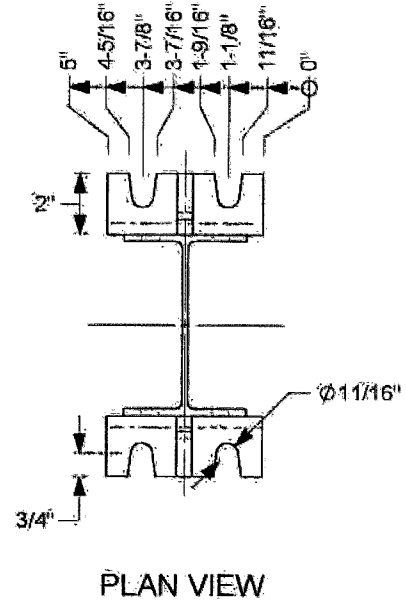
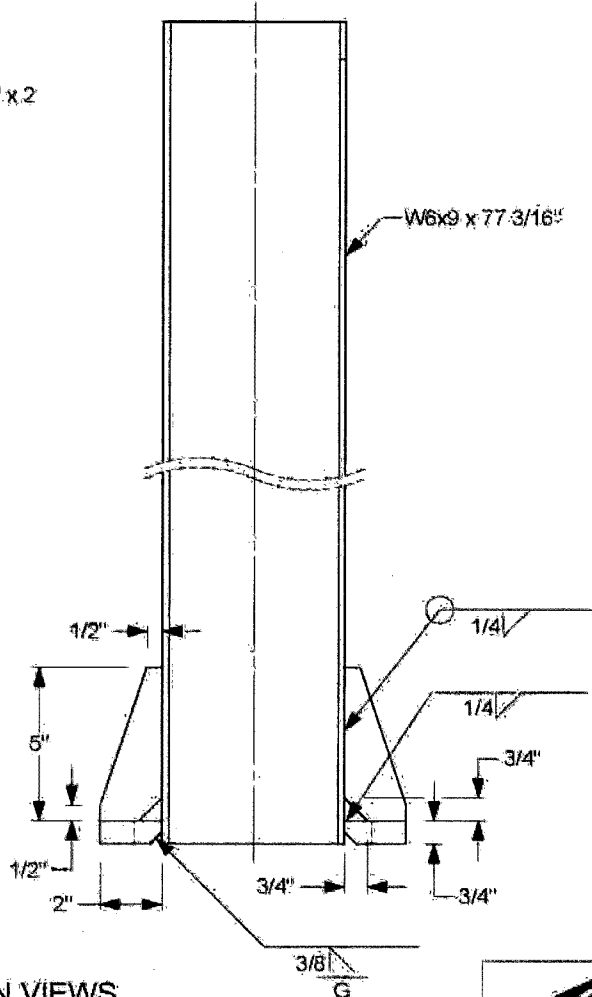

Roadside Safety and
Physical Security Division -
Proving Ground

Project 467823-4	Temporary Sign Support - Steel Posts	2013-06-04
Drawn By GES	Scale 1:5	Sheet 2 of 4 Middle Section

T:\2012-2013\467823-1\DOT Temp Sign Support\467823-4\Drafting\467823-4 Drawing

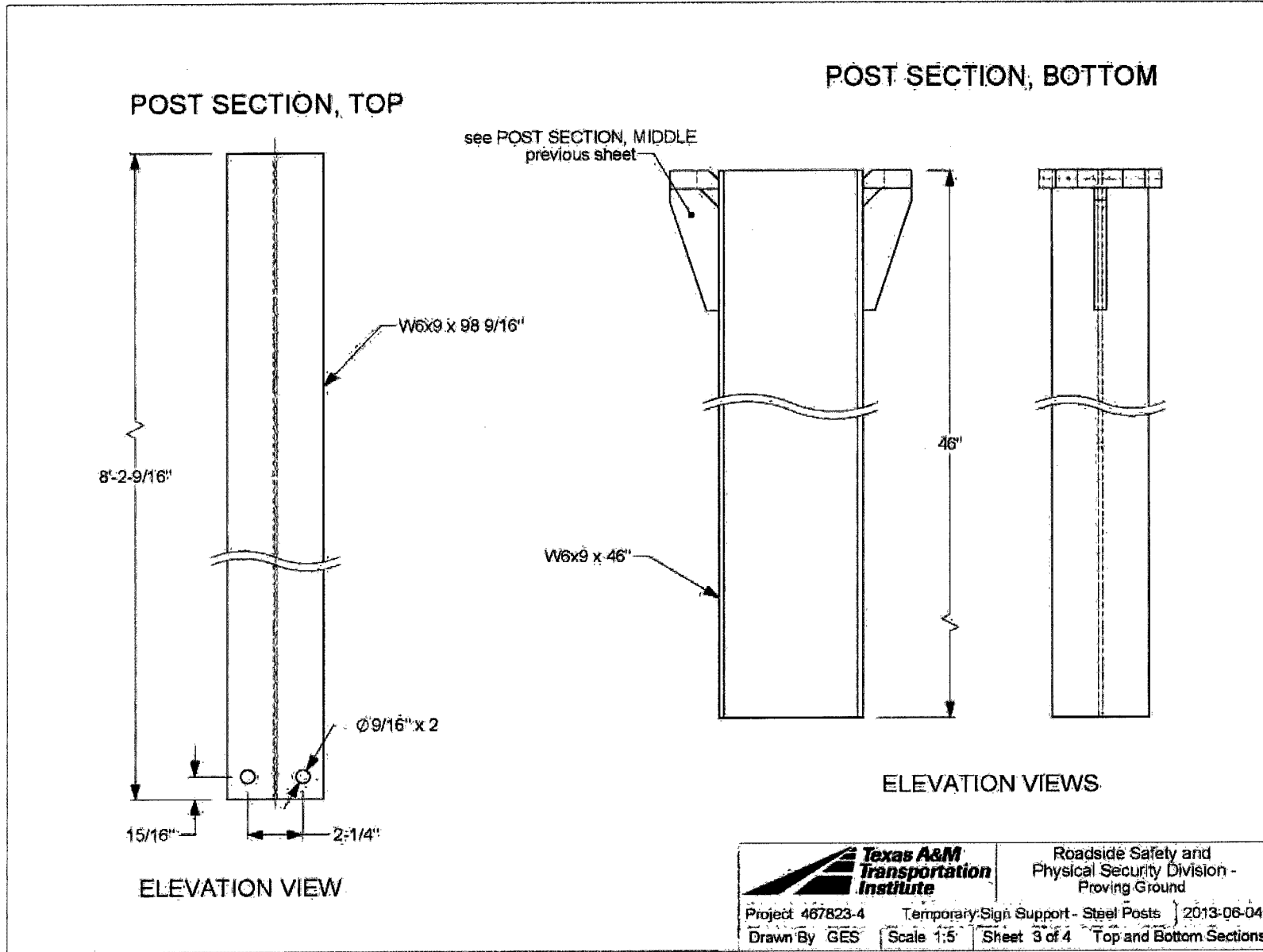

T:\2012-2013\467823-TxDOT Temp Sign Support\467823-4\Drafting\467823-4 Drawing

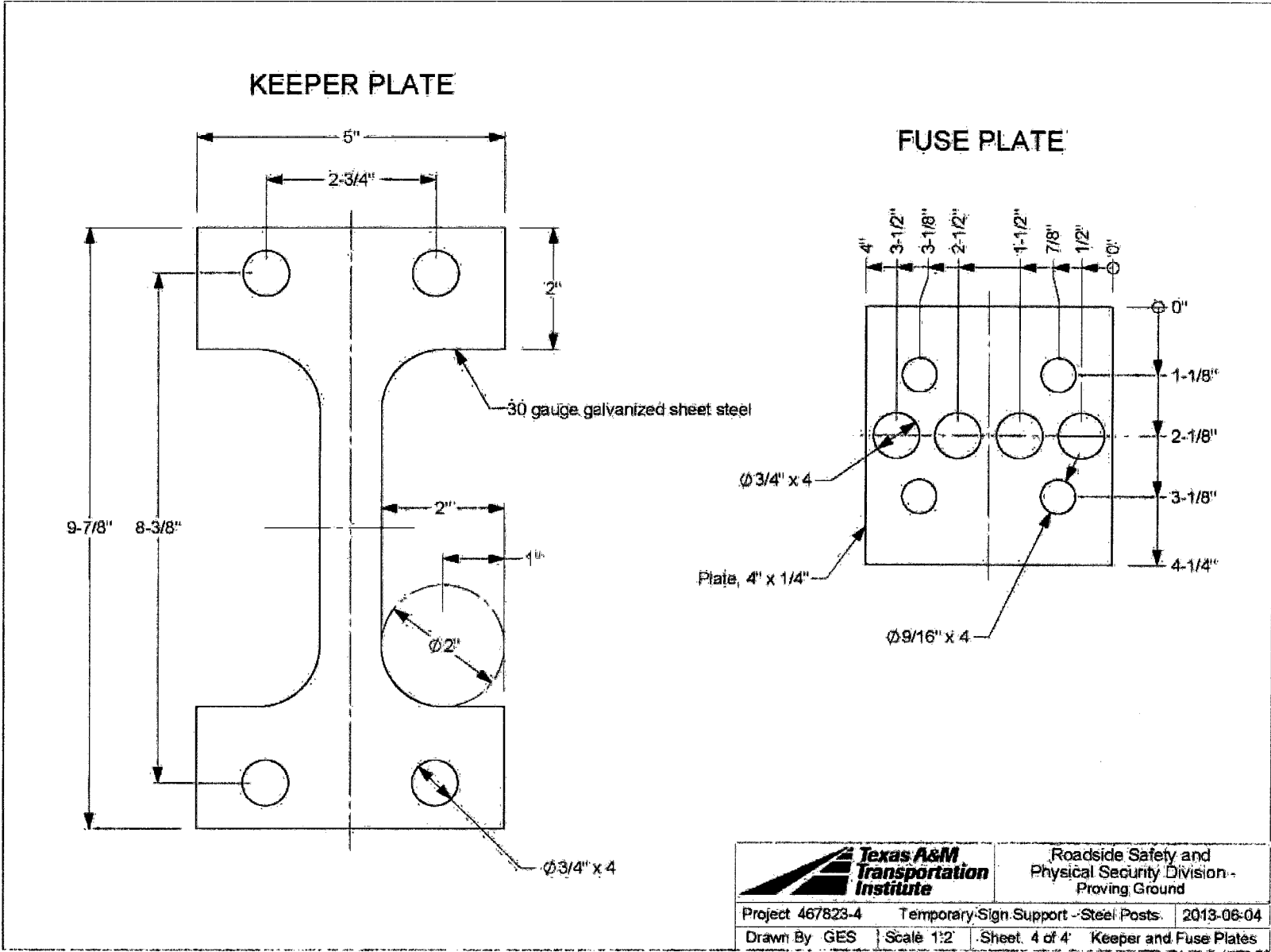

		Roadside Safety and Physical Security Division - Proving Ground
Project 467823-4	Temporary Sign Support - Steel Posts	2013-06-04
Drawn By GES	Scale 1:2	Sheet 4 of 4 Keeper and Fuse Plates

T:\2012-2013\467823-TxDOT Temp Sign Support\467823-4\Drafting\467823-4 Drawing

APPENDIX H. CRASH TEST NO. 467823-4

H.1 TEST VEHICLE PROPERTIES AND INFORMATION

Table H1. Vehicle Properties for Test No. 467823-4.

Date: 2013-07-02 Test No.: 467823-4 VIN No.: KNADE123776211118

Year: 2007 Make: Kia Model: Rio

Tire Inflation Pressure: 32 psi Odometer: 88959 Tire Size: 165/65R14

Describe any damage to the vehicle prior to test: _____

• Denotes accelerometer location.

NOTES: _____

Engine Type: 4 cylinder

Engine CID: 1.6 liter

Transmission Type:

 Auto or x Manual
 x FWD RWD 4WD

Optional Equipment:
None

Dummy Data:

Type: 50th percentile male

Mass: 183 lb

Seat Position: Driver

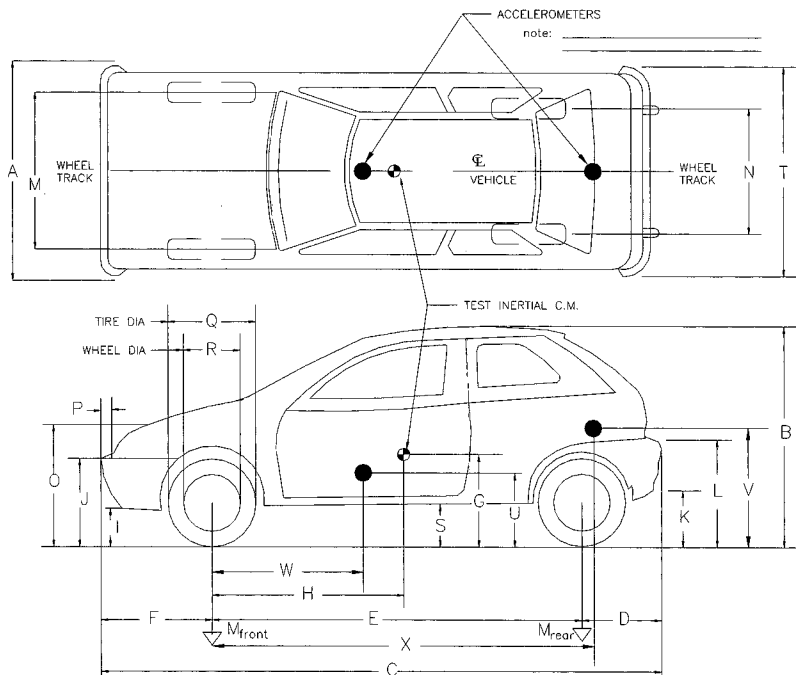

Geometry: inches

A	<u>66.38</u>	F	<u>33.00</u>	K	<u>11.00</u>	P	<u>4.12</u>	U	<u>16.00</u>
B	<u>57.75</u>	G	<u>----</u>	L	<u>24.12</u>	Q	<u>22.14</u>	V	<u>22.00</u>
C	<u>165.75</u>	H	<u>37.59</u>	M	<u>57.75</u>	R	<u>15.38</u>	W	<u>43.00</u>
D	<u>34.00</u>	I	<u>7.12</u>	N	<u>57.12</u>	S	<u>7.62</u>	X	<u>108.00</u>
E	<u>98.75</u>	J	<u>21.00</u>	O	<u>30.62</u>	T	<u>66.12</u>		

Wheel Center Ht Front 11.00 Wheel Center Ht Rear 11.00

GVWR Ratings:	Mass: lb	Curb	Test Inertial	Gross Static
Front	<u>1918</u>	M_{front}	<u>1479</u>	<u>1601</u>
Back	<u>1874</u>	M_{rear}	<u>869</u>	<u>1007</u>
Total	<u>3638</u>	M_{Total}	<u>2348</u>	<u>2608</u>

Mass Distribution:

lb LF: 799 RF: 703 LR: 437 RR: 486

Table H3. Occupant Compartment Measurements for Test No. 467823-4.

Date: 2013-07-02 Test No.: 467823-4 VIN No.: KNADE123776211118
 Year: 2007 Make: Kia Model: Rio

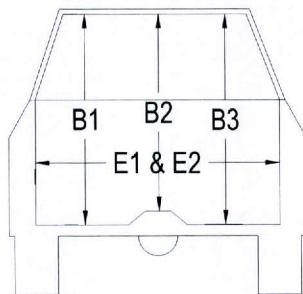
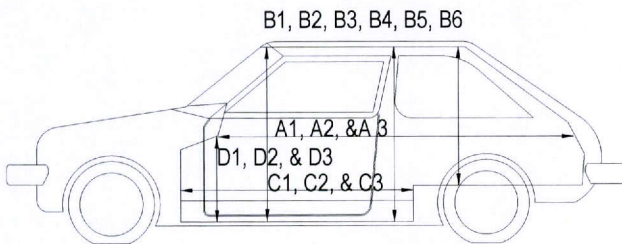
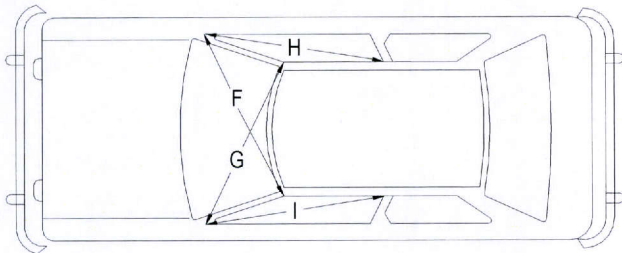

OCCUPANT COMPARTMENT DEFORMATION MEASUREMENT

	Before (inches)	After (inches)
A1	67.50	67.50
A2	67.50	67.50
A3	67.50	67.50
B1	40.50	40.50
B2	39.25	39.25
B3	40.50	40.50
B4	36.25	36.25
B5	36.00	36.00
B6	36.25	36.25
C1	27.00	27.00
C2	----	----
C3	26.00	26.00
D1	9.75	9.75
D2	----	----
D3	9.50	9.50
E1	48.00	48.00
E2	51.00	51.00
F	51.00	51.00
G	51.00	51.00
H	37.50	37.50
I	37.50	37.50
J*	51.00	51.00

*Lateral area across the cab from driver's side kickpanel to passenger's side kickpanel.

H.2 SEQUENTIAL PHOTOGRAPHS

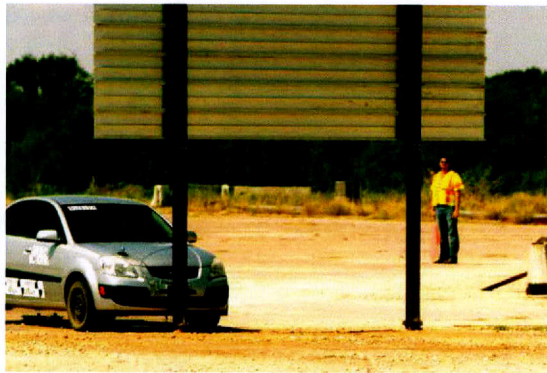

0.000 s



0.265 s



0.530 s



0.795 s



Figure H1. Sequential Photographs for Test No. 467823-4(Oblique and Perpendicular Views).



1.060 s

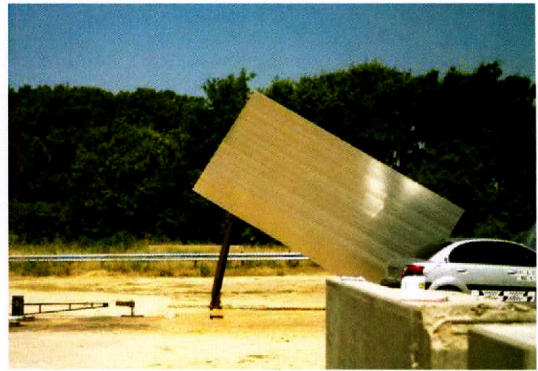

1.325 s

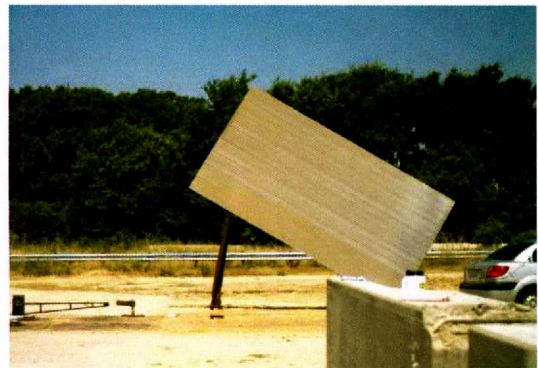

1.590 s

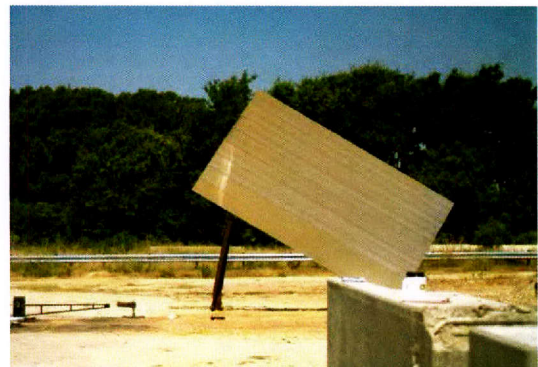

1.855 s

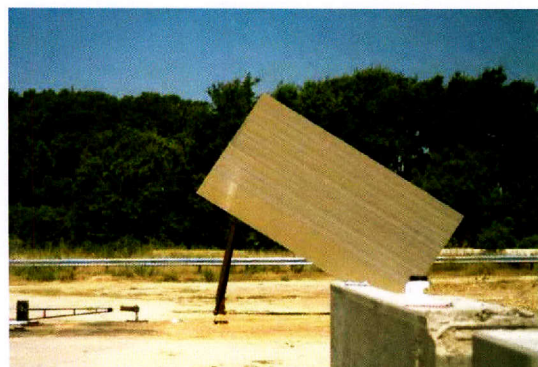
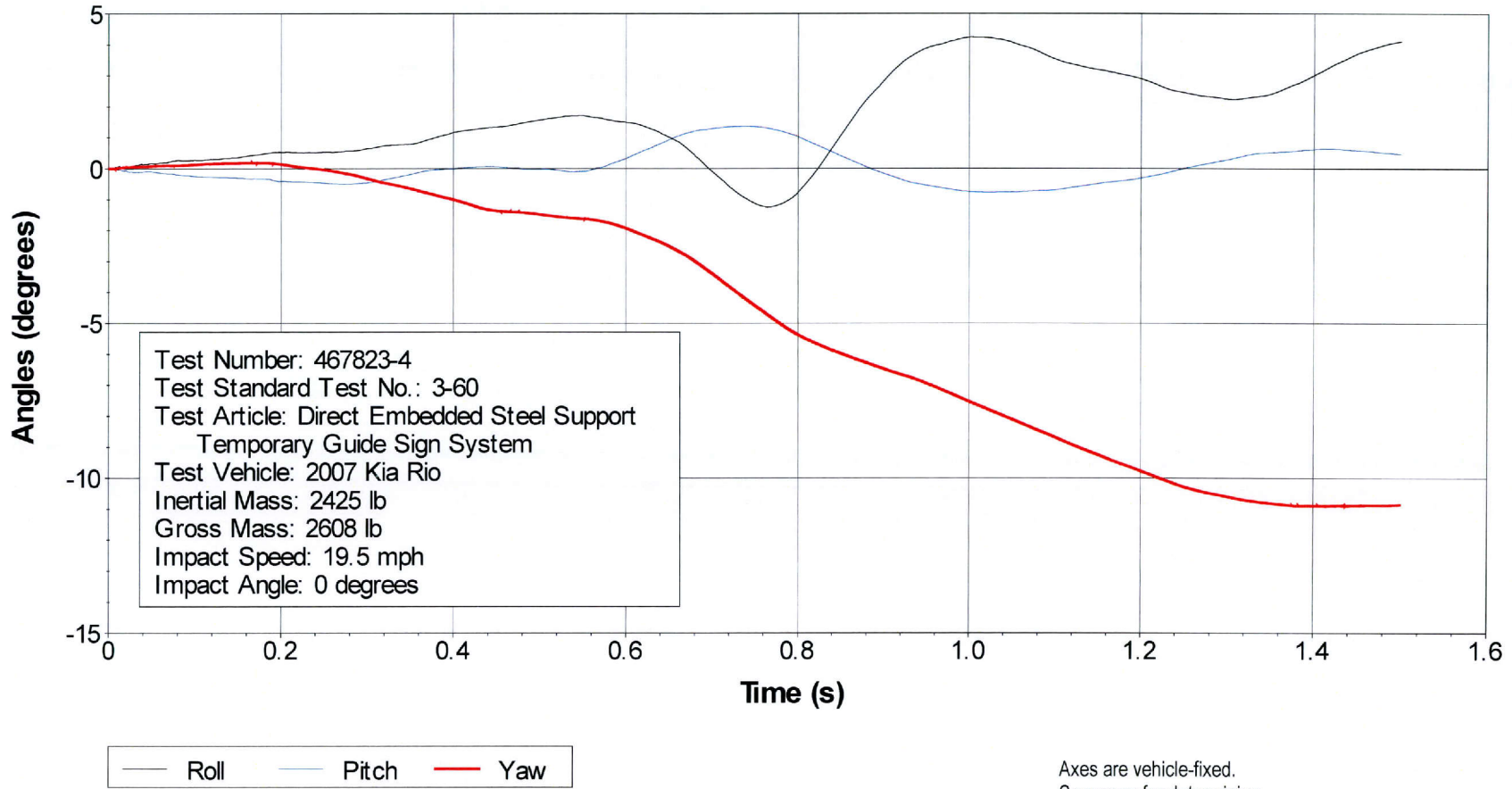

Figure H1. Sequential Photographs for Test No. 467823-4 (Oblique and Perpendicular Views) (Continued).

Roll, Pitch, and Yaw Angles



Axes are vehicle-fixed.
 Sequence for determining orientation:

1. Yaw.
2. Pitch.
3. Roll.

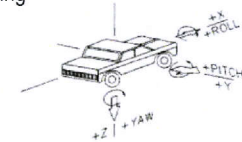

Figure H2. Vehicle Angular Displacements for Test No. 467823-4.

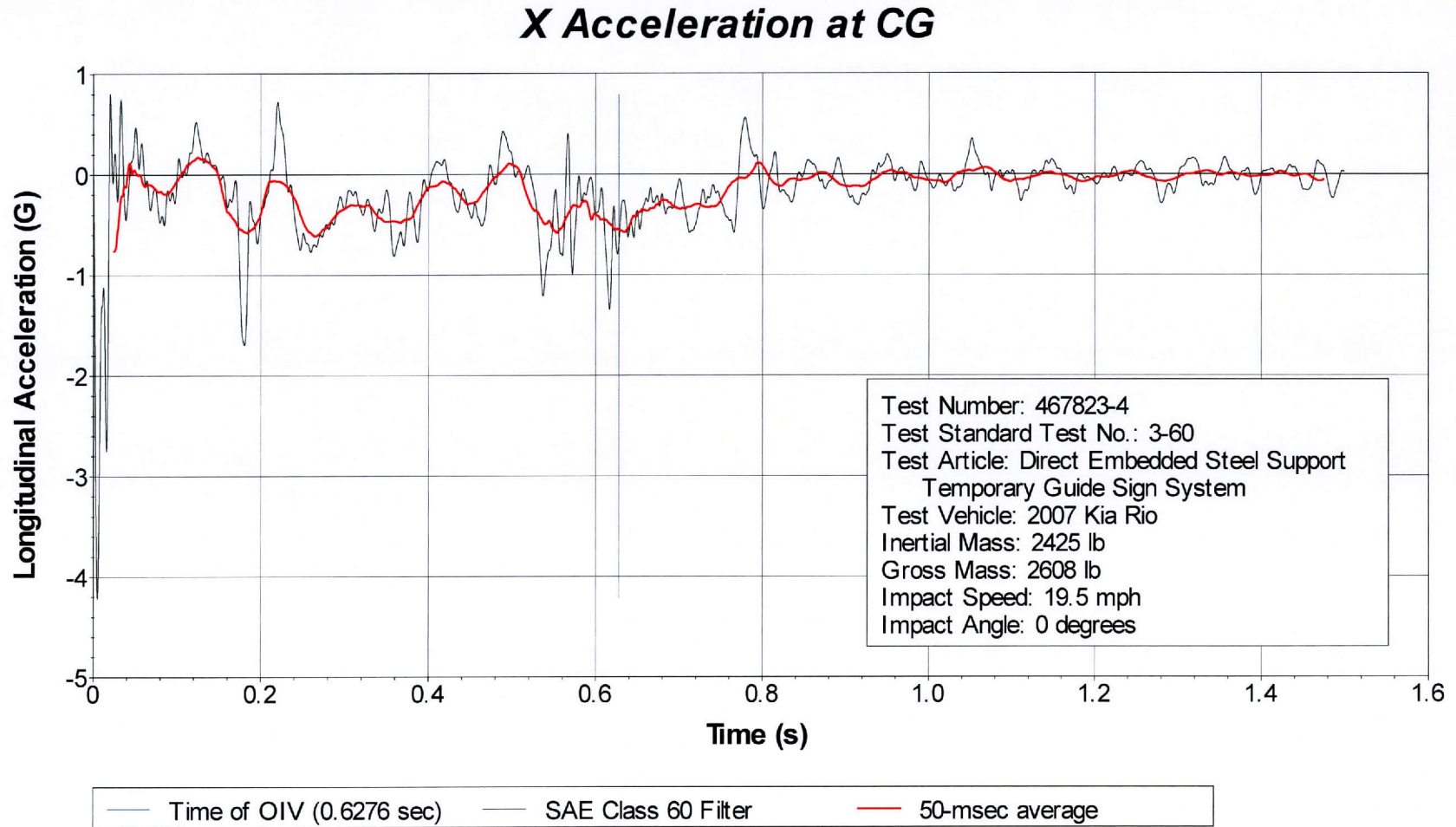

Figure H3. Vehicle Longitudinal Accelerometer Trace for Test No. 467823-4 (Accelerometer Located at Center of Gravity).

Y Acceleration at CG

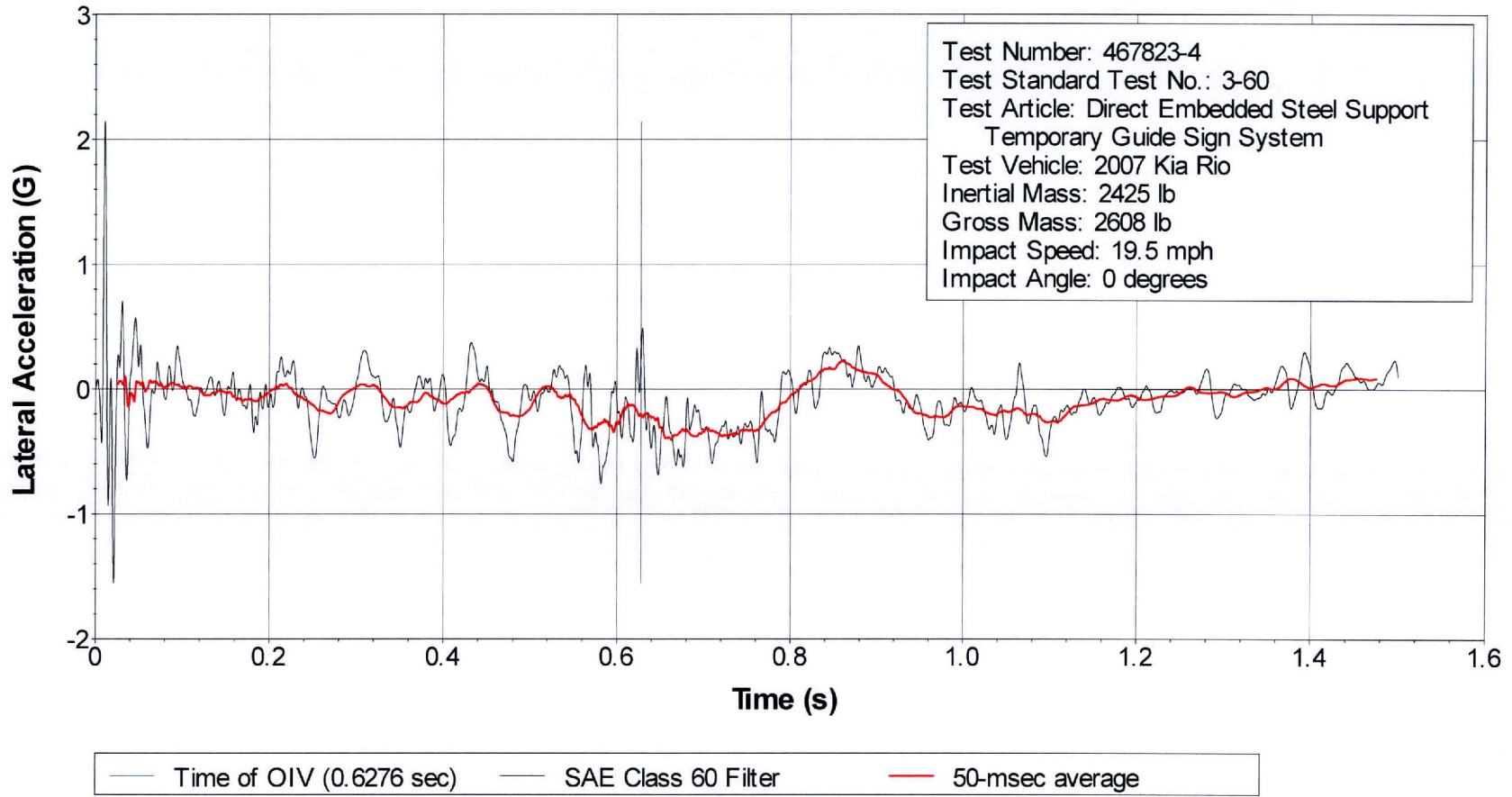

Figure H4. Vehicle Lateral Accelerometer Trace for Test No. 467823-4 (Accelerometer Located at Center of Gravity).

Z Acceleration at CG

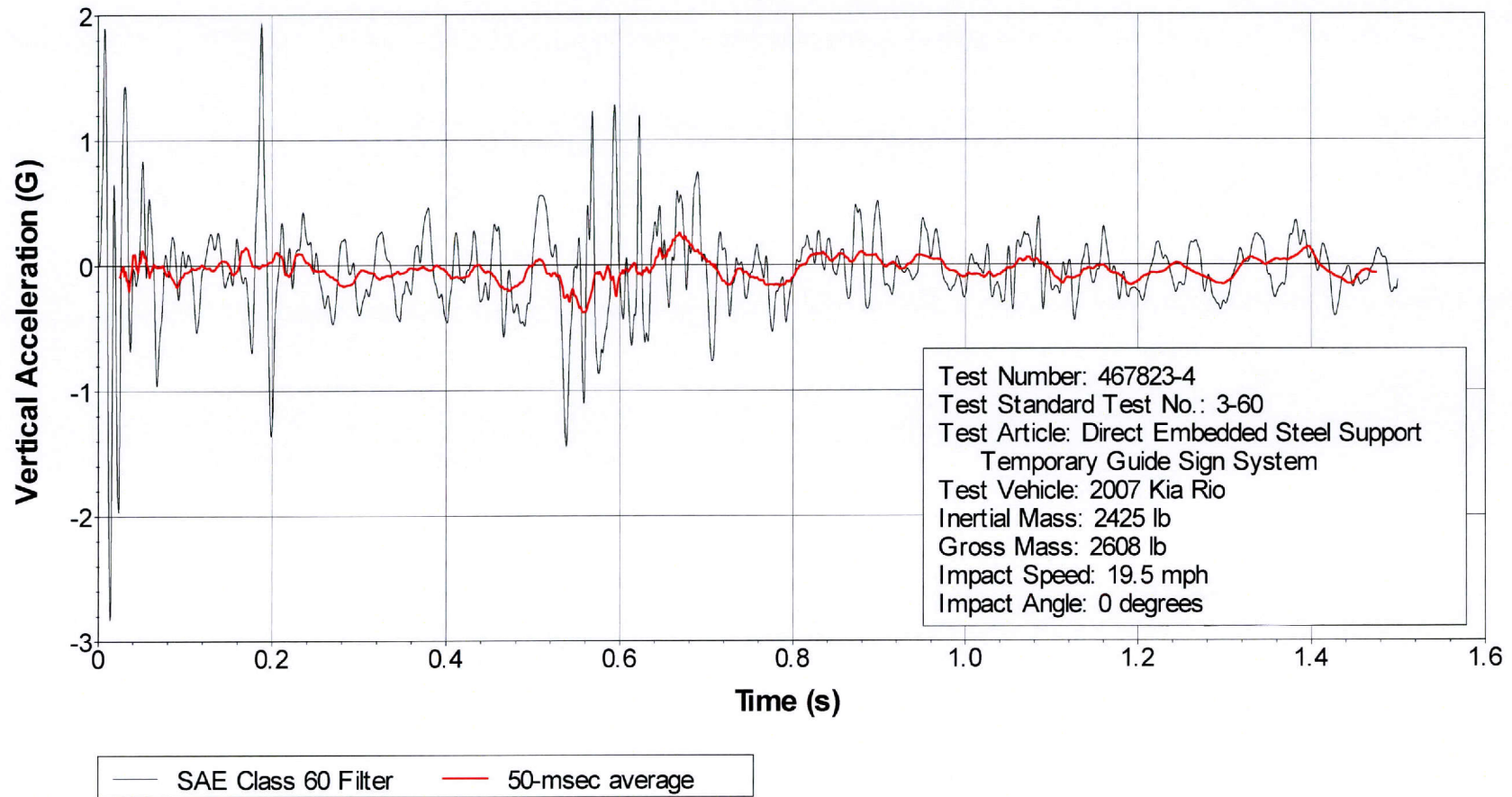

Figure H5. Vehicle Vertical Accelerometer Trace for Test No. 467823-4 (Accelerometer Located at Center of Gravity).

X Acceleration Rear of CG

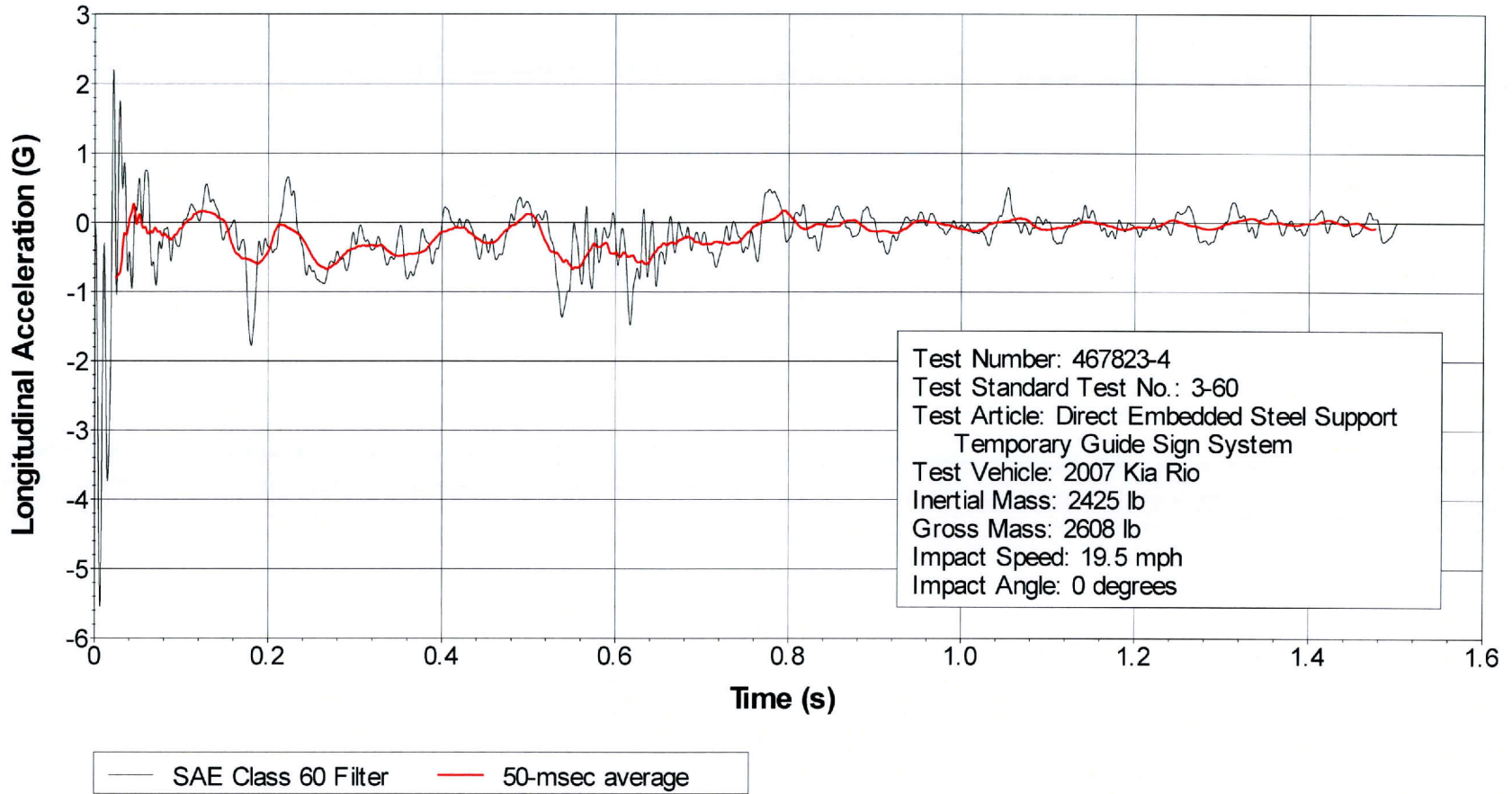

Figure H6. Vehicle Longitudinal Accelerometer Trace for Test No. 467823-4 (Accelerometer Located Rear of Center of Gravity).

Y Acceleration Rear of CG

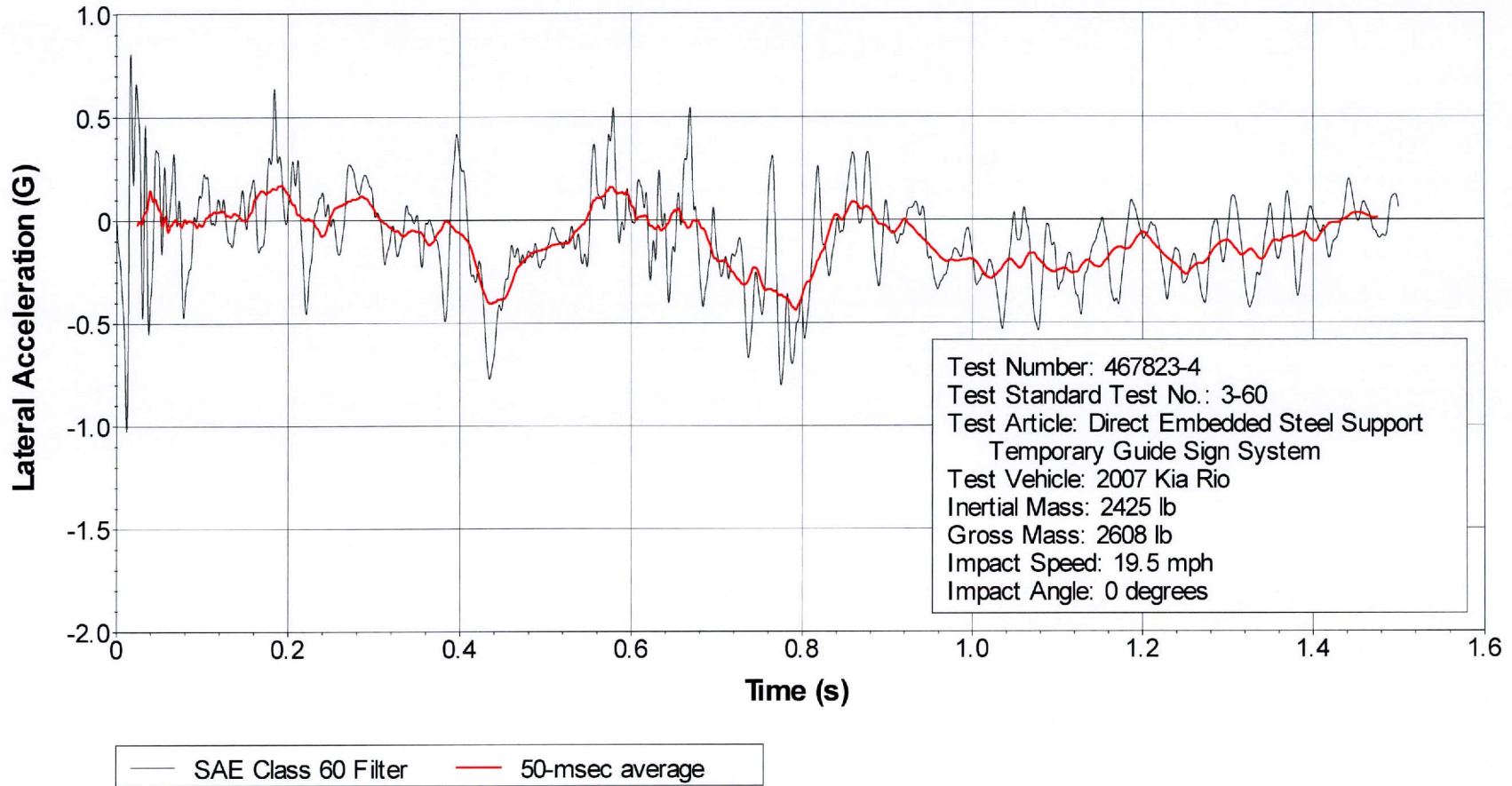

Figure H7. Vehicle Lateral Accelerometer Trace for Test No. 467823-4 (Accelerometer Located Rear of Center of Gravity).

Z Acceleration Rear of CG

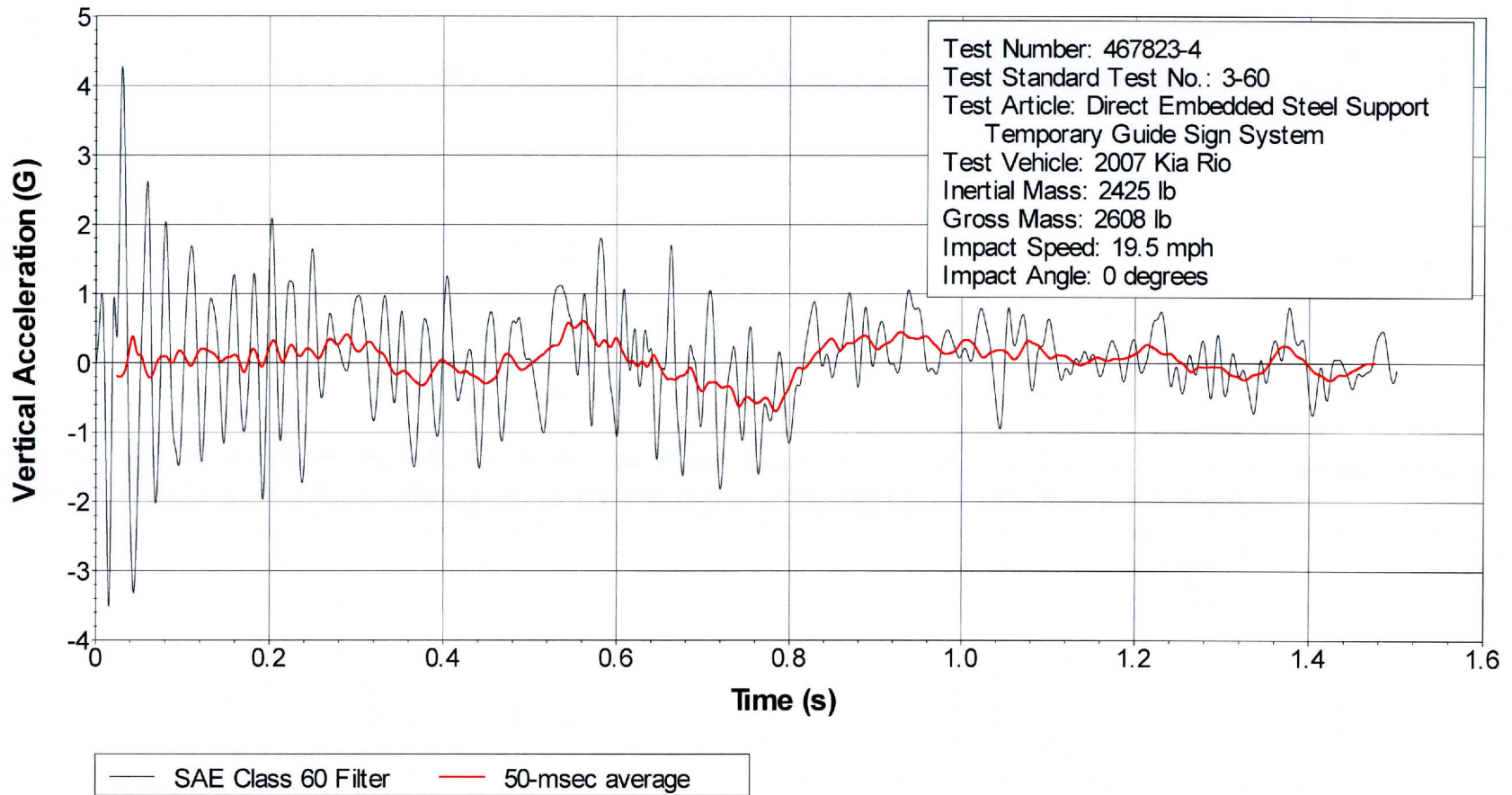

Figure H8. Vehicle Vertical Accelerometer Trace for Test No. 467823-4 (Accelerometer Located Rear of Center of Gravity).

Texas A&M Transportation Institute
College Station, TX 77843-3135
979-845-1734
<http://tti.tamu.edu>