



---

# Characteristics of Texas Pedestrian Crashes and Evaluation of Driver Yielding at Pedestrian Treatments

Technical Report 0-6702-1

---

Cooperative Research Program

TEXAS A&M TRANSPORTATION INSTITUTE  
COLLEGE STATION, TEXAS

in cooperation with the  
Federal Highway Administration and the  
Texas Department of Transportation  
<http://tti.tamu.edu/documents/0-6702-1.pdf>



1. Report No. FHWA/TX-13/0-6702-1		2. Government Accession No.		3. Recipient's Catalog No.	
4. Title and Subtitle CHARACTERISTICS OF TEXAS PEDESTRIAN CRASHES AND EVALUATION OF DRIVER YIELDING AT PEDESTRIAN TREATMENTS				5. Report Date Published: May 2014	
				6. Performing Organization Code	
7. Author(s) Kay Fitzpatrick, Vichika Iragavarapu, Marcus A. Brewer, Dominique Lord, Joan Hudson, Raul Avelar, and James Robertson				8. Performing Organization Report No. Report 0-6702-1	
9. Performing Organization Name and Address Texas A&M Transportation Institute College Station, Texas 77843-3135				10. Work Unit No. (TRAIS)	
				11. Contract or Grant No. Project 0-6702	
12. Sponsoring Agency Name and Address Texas Department of Transportation Research and Technology Implementation Office 125 E. 11 <sup>th</sup> Street Austin, Texas 78701-2483				13. Type of Report and Period Covered Technical Report: September 2011–August 2013	
				14. Sponsoring Agency Code	
15. Supplementary Notes Project performed in cooperation with the Texas Department of Transportation and the Federal Highway Administration. Project Title: Development of Pedestrian Crash Countermeasures and Appropriate Crash Reduction Factors (CRFs) URL: <a href="http://tti.tamu.edu/documents/0-6702-1.pdf">http://tti.tamu.edu/documents/0-6702-1.pdf</a>					
16. Abstract For Texas, the average number of pedestrian fatalities for 2007 to 2011 is about 400 per year. Due to the high number of pedestrian crashes, Texas is considered by the Federal Highway Administration (FHWA) to be a “focus” state. Researchers found that 2 percent of all Texas Department of Transportation (TxDOT)-reportable traffic crashes and 15 percent of all TxDOT-reportable fatal crashes were pedestrian related. Most non-fatal crashes are associated with daylight, at intersections, and on city streets, whereas most fatal crashes are associated with dark conditions, midblock locations, and high-speed roadways. Twenty-one percent of all fatal TxDOT-reportable pedestrian crashes occurred on freeways—a location where pedestrians are least expected. Additional research into how to address pedestrian crashes, especially freeway crashes, is needed, perhaps using FHWA’s new systematic safety project selection tool. In the past decade, the pedestrian hybrid beacon (PHB) and rectangular rapid-flashing beacon (RRFB) have shown great potential in improving driver yielding rates and conditions for crossing pedestrians. Researchers conducted a field study at 7 traffic control signal (TCS) sites, 22 RRFB sites, and 32 PHB sites in Texas with the effectiveness measure being the percent of drivers yielding to a staged pedestrian. Results showed that driver yielding rates varied by type of treatment. Overall, TCSs in Texas have the highest driver yielding rates (98 percent), followed by PHBs (89 percent) and RRFBs (86 percent). Those cities with a greater number of a particular device (i.e., Austin for the PHB and Garland for the RRFB) had higher driver yielding rates as compared to cities where the device was only used at a few crossings. Also, as drivers became more familiar with the PHB, a greater proportion yielded, perhaps because they gained a better understanding of expectations or requirements over time. As part of this study, researchers conducted a before-and-after field study at four RRFB sites and one PHB site to identify the changes in driver yielding and selected pedestrian behaviors resulting from installing these treatments at previously untreated crosswalks. The installations resulted in noticeable improvement in the number of yielding vehicles.					
17. Key Words Pedestrian Crashes, Pedestrian Treatments, Funding, Pedestrian Hybrid Beacon, Rectangular Rapid-Flashing Beacon			18. Distribution Statement No restrictions. This document is available to the public through NTIS: National Technical Information Service Alexandria, Virginia 22312 <a href="http://www.ntis.gov">http://www.ntis.gov</a>		
19. Security Classif. (of this report) Unclassified		20. Security Classif. (of this page) Unclassified		21. No. of Pages 290	22. Price



# **CHARACTERISTICS OF TEXAS PEDESTRIAN CRASHES AND EVALUATION OF DRIVER YIELDING AT PEDESTRIAN TREATMENTS**

by

**Kay Fitzpatrick, Ph.D., P.E.**

Senior Research Engineer, Texas A&M Transportation Institute

**Vichika Iragavarapu, P.E.**

Assistant Research Engineer, Texas A&M Transportation Institute

**Marcus A. Brewer, P.E.**

Associate Research Engineer, Texas A&M Transportation Institute

**Dominique Lord, Ph.D., P.Eng.**

Associate Professor, Texas A&M University

**Joan Hudson, P.E.**

Associate Research Engineer, Texas A&M Transportation Institute

**Raul Avelar, Ph.D.**

Associate Research Scientist, Texas A&M Transportation Institute

and

**James Robertson**

Graduate Assistant Research, Texas A&M Transportation Institute

Report 0-6702-1

Project 0-6702

Project Title: Development of Pedestrian Crash Countermeasures and Appropriate Crash  
Reduction Factors (CRFs)

Performed in cooperation with the  
Texas Department of Transportation  
and the  
Federal Highway Administration

Published: May 2014

TEXAS A&M TRANSPORTATION INSTITUTE  
College Station, Texas 77843-3135



## **DISCLAIMER**

The contents of this report reflect the views of the authors, who are responsible for the facts and the accuracy of the data presented herein. The contents do not necessarily reflect the official view or policies of the Federal Highway Administration (FHWA) or the Texas Department of Transportation (TxDOT). The United States Government and the State of Texas do not endorse products or manufacturers. Trade or manufacturers' names appear herein solely because they are considered essential to the object of this report. This report does not constitute a standard, specification, or regulation. The engineer in charge was Kay Fitzpatrick, P.E. (TX-86762).

## ACKNOWLEDGMENTS

This project was conducted in cooperation with TxDOT and FHWA.

The authors thank the members of TxDOT's Project Monitoring Committee:

- Debra Vermillion, TxDOT Traffic Operations Division, project advisor.
- Amanda Martinez, TxDOT Traffic Operations Division, project advisor.
- Christopher Lindsey, TxDOT Design Division, project advisor.
- Scott Cunningham, TxDOT Austin District, project director.
- Steve Higgins, TxDOT Bryan District, project director.
- Wade Odell, P.E., TxDOT Research and Technology Implementation Office, research engineer.
- Cary Choate, TxDOT Research and Technology Implementation Office, project manager.
- Darrin Jensen, TxDOT Research and Technology Implementation Office, project manager.

The authors also thank the following Texas A&M Transportation Institute (TTI) employees who provided guidance or assistance during the project, assisted with data collection, or performed data reduction for the studies on this project:

- Amanda Martin, student worker.
- Blanca Garcia, student worker.
- Carla Beltran, student worker.
- Chris White, student worker.
- Colleen Dau, lead office assistant.
- Dan Walker, assistant research specialist.
- Daren Mieles, student worker.
- Diana Wallace, research technician.
- Gary Barricklow, research technician.
- Hadi Khazraee Khoshroozi, graduate student.
- Hailey Minter, student worker.
- Jared Buckler, student worker.
- Jesse Ortega, research assistant.
- Martin Fuest, student worker.
- Mehdi Azimi, graduate student.
- Michael Pratt, assistant research engineer.
- Ross Langdale, student worker.
- Sarah Motes, student worker.
- Seth Cole, student technician.



## TABLE OF CONTENTS

	Page
<b>LIST OF FIGURES</b> .....	<b>xiv</b>
<b>LIST OF TABLES</b> .....	<b>xvii</b>
<b>CHAPTER 1 INTRODUCTION</b> .....	<b>1</b>
Research Objectives.....	1
Report Organization.....	1
<b>CHAPTER 2 LITERATURE REVIEW – PEDESTRIAN CHARACTERISTICS</b> .....	<b>3</b>
Pedestrians .....	3
Reasons for Walking or Not Walking.....	3
Settings (Urban versus Rural).....	4
Pedestrian Walking Speed .....	4
Pedestrian Space Requirements .....	4
Pedestrian Age .....	5
Facility Preferences.....	6
Summary .....	6
<b>CHAPTER 3 LITERATURE REVIEW – SAFETY EVALUATIONS</b> .....	<b>7</b>
Factors Contributing to Pedestrian Crashes.....	7
Pedestrian Crash Types.....	7
Predicting Pedestrian Crashes.....	9
Crash Modification Factors.....	9
Systematic Safety Selection Tool .....	11
MnDOT Example.....	13
Summary .....	15
<b>CHAPTER 4 LITERATURE REVIEW – TREATMENTS</b> .....	<b>17</b>
Engineering .....	17
Engineering Treatments – Traffic Control Devices.....	18
Advance Yield Line and Sign.....	18
Beacons.....	18
Crosswalk Marking Patterns .....	20
Flags.....	21
In-Roadway Warning Lights at Crosswalks .....	22
In-Street Pedestrian Crossing Signs.....	26
Leading Pedestrian Interval .....	27
Marked Crosswalks.....	27
Motorist Warning Signs.....	30
Pedestrian Countdown Signal .....	31
Pedestrian Hybrid Beacon (Also Known as HAWK).....	31
Puffin.....	32
Rectangular Rapid-Flashing Beacon.....	33
Traffic Control Signal.....	37
Zigzag Lines.....	38
Engineering Treatments – Geometric Design.....	38
Barrier – Median.....	38

Barrier – Roadside and Sidewalk.....	39
Bus Stop Location.....	40
Curb Extensions.....	41
Illumination.....	43
Overpasses and Underpasses.....	45
Raised Crosswalks.....	47
Refuge Islands.....	47
Road Diets.....	50
Sidewalks.....	50
Multiple Treatments.....	51
Education.....	53
Education Audience.....	54
Road Users – Child Pedestrians.....	54
Road Users – College-Age Student Pedestrians.....	54
Road Users – Alcohol Consumer Pedestrians.....	55
Road Users – Adult Pedestrians.....	55
Road Users – Older Pedestrians.....	55
Road Users – Drivers.....	55
Commuters/Employees.....	56
Transportation Officials and Decision-Makers.....	56
Education without Enforcement or Engineering Treatments.....	56
Public Awareness Campaigns.....	57
Public Involvement Workshops.....	58
Education with Enforcement.....	58
Education with Enforcement and Engineering.....	60
Education of Children.....	60
Curriculum-Based Education.....	60
Media-Based Education.....	61
One-Time Instruction.....	61
Skills-Based Training.....	62
Virtual Reality.....	62
WalkSafe.....	63
Non-English Translation of Education Materials.....	63
Connection between Education and Crashes.....	64
Enforcement.....	64
Vehicle Code Awareness.....	65
Driver and Pedestrian Vehicle Code Awareness.....	65
Police Officer Vehicle Code Awareness.....	66
Enforcement Types.....	66
Targeted Routine Enforcement.....	66
High-Visibility Enforcement.....	66
Staged Crossings with Decoy Pedestrians (Police Officers).....	67
Automated Enforcement.....	67
Targeted Enforcement Strategies.....	68
Education Materials in Lieu of Citations.....	68
Citations for Pedestrian Right-of-Way Violations.....	69

Fines for Pedestrian Right-of-Way Violations .....	69
Prosecution of Pedestrian Right-of-Way Violations.....	69
Citations after a Period of Enforcement Using Education Materials.....	69
Countermeasure Costs .....	70
Summary .....	70
<b>CHAPTER 5 FUNDING OPPORTUNITIES FOR PEDESTRIAN SAFETY</b>	
<b>IMPROVEMENTS .....</b>	<b>73</b>
Overview.....	73
Federal Funding .....	73
Surface Transportation Environment and Planning Cooperative Research Program (STEP).....	73
Transportation Enhancement (TE) Program.....	73
Transportation, Community, and System Preservation (TCSP) Program .....	74
Federal Lands Highway Program .....	75
The National Scenic Byways Program .....	75
Transit Enhancement Funds.....	76
Federal Transit Administration Grants .....	76
Alternative Transportation in Parks and Public Lands (ATPPL) .....	76
High-Priority Projects.....	77
Safe Routes to School.....	77
Surface Transportation Program .....	77
Surface Transportation Program – Metropolitan Mobility (STP-MM) .....	78
Congestion Mitigation and Air Quality Program.....	78
Section 402 Highway Safety Funds.....	78
Highway Safety Improvement Program .....	79
Recreational Trails Program .....	79
Transportation Investment Generating Economic Recovery (TIGER) Discretionary Grants Program .....	79
U.S. Department of Energy, Energy Efficiency and Conservation Block Grant Program.....	80
State of Texas Funding .....	80
Texas Community Development Block Grant (TxCDBG) Program.....	80
WalkWell Texas.....	81
States Other Than Texas .....	81
California Pedestrian Safety Assessments (PSAs) .....	81
Florida Department of Transportation (FDOT).....	81
Maryland DOT State Highway Administration Transportation Alternatives Program.....	82
Massachusetts Executive Office of Public Safety and Security .....	82
NCDOT Division of Bicycle and Pedestrian Transportation and the Transportation Branch .....	82
Washington Traffic Safety Commission.....	82
Non-Profit Funding.....	83
Robert Wood Johnson Foundation (RWJF).....	83
AARP Foundation Grants Program .....	84
Boltage (Formerly Freiker).....	84

Summary .....	84
<b>CHAPTER 6 QUESTIONNAIRE ON PEDESTRIAN SAFETY TREATMENTS .....</b>	<b>85</b>
Introduction.....	85
List of Questions .....	85
Responses.....	86
Question 1: Pedestrian Safety-Related Problems .....	86
Intersection Crossings.....	86
Non-Intersection Locations.....	87
Dart/Dash and Multiple-Threat Pedestrian Crossings .....	87
Nighttime Crashes and Freeway Pedestrian Crashes.....	88
Other Issues.....	88
Question 2: Examples of Pedestrian Safety Treatments .....	88
Question 3: Limitations on Implementing Pedestrian Safety Treatments .....	90
Question 4: Treatments Considered but Not Installed .....	91
Question 5: Additional Useful Information .....	91
Summary .....	91
<b>CHAPTER 7 EXAMINATION OF THE RELATIONSHIP BETWEEN</b>	
<b>    ROADWAY CHARACTERISTICS AND DRIVER YIELDING TO</b>	
<b>    PEDESTRIANS.....</b>	<b>93</b>
Introduction.....	93
Background.....	93
Objective .....	95
Field Study Methodology .....	96
Site Selection .....	96
Site Characteristics.....	97
Data Collection .....	102
Data Reduction.....	104
Analysis.....	104
Preliminary Analyses .....	104
Modeling Approach .....	105
Comparison of Texas Average Results to Other Studies.....	106
Differences by Treatment Type .....	107
City or Density of Treatment.....	109
Analysis By Treatment .....	109
Traffic Control Signals .....	110
Pedestrian Hybrid Beacon.....	110
Rectangular Rapid-Flashing Beacon.....	113
Analysis By Nearside and Farside .....	117
Pedestrian Hybrid Beacon.....	117
Rectangular Rapid-Flashing Beacon.....	120
Analysis by Time Since Installation .....	122
Summary .....	125
<b>CHAPTER 8 PEDESTRIAN AND DRIVER BEHAVIOR BEFORE AND AFTER</b>	
<b>    INSTALLATION OF PEDESTRIAN TREATMENTS .....</b>	<b>127</b>
Background.....	127
Objective .....	127

Field Study Methodology .....	127
Study Site Description .....	129
Data Collection .....	130
Data Reduction.....	131
Data Analysis.....	132
Driver Yielding Rates .....	132
Yielding for All Pedestrian Crossings .....	133
Yielding for Staged Pedestrian Crossings.....	134
Nearside and Farside Yielding for Staged Pedestrian Crossings.....	135
Pedestrian Crossing Volumes .....	135
Number of Pedestrian Crossings.....	135
Pedestrian Crossings per Hour.....	137
Non-Staged Pedestrian Behavior .....	138
Activation.....	138
Active Use of Electronics .....	138
Pedestrian Waiting Position.....	139
Pedestrian Searching Behavior .....	139
Pedestrian Starting Behavior.....	141
Pedestrian Crossing Mode and Assistive Apparatus .....	142
Pedestrian Behavior While Approaching Second Lane.....	143
Number of Pedestrians in Crossing Group .....	144
Summary .....	144
<b>CHAPTER 9 IN-DEPTH REVIEW OF TEXAS PEDESTRIAN CRASHES .....</b>	<b>145</b>
Background.....	145
Data Assembly.....	146
Crash Characteristics .....	146
Geometric Characteristics (from Aerial Photographs) .....	149
Exploratory Analysis .....	150
Crash Characteristics .....	150
Geometric Characteristics (from Aerial Photographs) .....	160
Pedestrian Characteristics .....	164
Discussion.....	169
Summary.....	170
<b>CHAPTER 10 IN-DEPTH REVIEW OF TEXAS FATAL PEDESTRIAN</b>	
<b>CRASHES.....</b>	<b>171</b>
Background.....	171
Data Assembly.....	172
Exploratory Analysis .....	173
Crash Characteristics .....	173
Roadway Characteristics.....	178
Geometric Characteristics (from Aerial Photographs) .....	184
Person Characteristics.....	188
Socioeconomic Characteristics .....	193
Discussion.....	197
Summary.....	198

<b>CHAPTER 11 REVIEW OF FATAL PEDESTRIAN CRASHES ON HIGH-SPEED ROADS IN TEXAS .....</b>	<b>199</b>
Background .....	199
Data Assembly .....	199
Crash Data .....	199
Crash Narrative .....	200
Analysis .....	201
Roadway Type and Posted Speed Limit .....	201
Roadway Part .....	204
Person Characteristics .....	204
Influence of Alcohol and/or Drugs .....	206
Pedestrian Action at the Time of Crash .....	208
Reason for Pedestrian at Crash Location .....	209
Unit at Fault .....	212
Weather and Light Conditions .....	213
Crash Location .....	213
Discussion .....	216
Summary .....	217
<b>CHAPTER 12 ANALYSIS OF TEXAS PEDESTRIAN CRASHES USING CLASSIFICATION TREE MODELS .....</b>	<b>219</b>
Introduction .....	219
Methodology .....	220
Data .....	221
Analysis .....	230
Results .....	231
Non-Fatal Pedestrian Crashes .....	237
Fatal Pedestrian Crashes .....	237
Overview .....	237
Discussion .....	238
Summary .....	239
<b>CHAPTER 13 SUMMARY AND CONCLUSIONS .....</b>	<b>241</b>
Summary of Research .....	241
Literature Review .....	241
Overview .....	241
Findings .....	241
Funding Opportunities .....	242
Overview .....	242
Findings .....	242
Questionnaire on Pedestrian Safety Treatments .....	242
Overview .....	242
Findings .....	243
Relationship between Roadway Characteristics and Driver Yielding to Pedestrians .....	244
Overview .....	244
Findings .....	244
Pedestrian and Motorist Behavior Before and After Installation of Pedestrian Treatments .....	245

Overview.....	245
Findings.....	245
In-Depth Review of Texas Pedestrian Crashes.....	246
Overview.....	246
Findings.....	246
In-Depth Review of Texas Fatal Pedestrian Crashes.....	247
Overview.....	247
Findings.....	247
Review of Fatal Pedestrian Crashes on High-Speed Roads in Texas.....	248
Overview.....	248
Findings.....	248
Analysis of Texas Pedestrian Crashes Using Classification Tree Models .....	248
Overview.....	248
Findings.....	248
Conclusions.....	249
Future Research .....	251
<b>REFERENCES.....</b>	<b>253</b>

## LIST OF FIGURES

	<b>Page</b>
Figure 1. Illustration of Factors Associated with Pedestrian Crash Risk and/or Severity (Zegeer and Bushell, Accident Analysis and Prevention 2012) (4). .....	8
Figure 2. MnDOT Project Development Decision Tree (26). .....	14
Figure 3. Examples of Marking Types Used in Visibility Study (39). .....	21
Figure 4. School Crosswalk with RRFBs in Garland, Texas (73). .....	35
Figure 5. Texas' Safe Routes to School Apportionment. ....	78
Figure 6. Example of Traffic Control Signal Installation. ....	93
Figure 7. Example of Pedestrian Hybrid Beacon Installation.....	94
Figure 8. Example of a Sign Used with a Pedestrian Hybrid Beacon Installation. ....	94
Figure 9. Example of Rectangular Rapid-Flashing Beacon with School Crossing Sign Installation. ....	95
Figure 10. Example of Crossing Distance Measurements, Going from South to North. ....	101
Figure 11. Example of Crossing Distance Measurements, Going from North to South. ....	102
Figure 12. Staged Pedestrian Crossing at a Crosswalk with Pedestrian Hybrid Beacon.....	103
Figure 13. Pedestrian Hybrid Beacon: Driver Yielding by Total Crossing Distance.....	112
Figure 14. Pedestrian Hybrid Beacon: Driver Yielding by Posted Speed Limit. ....	112
Figure 15. Rectangular Rapid-Flashing Beacon: Driver Yielding by Posted Speed Limit. ....	115
Figure 16. Rectangular Rapid-Flashing Beacon: Driver Yielding by Total Crossing Distance. ....	117
Figure 17. Example of Trailer Position.....	129
Figure 18. Screenshot of Video of Staged Crossing. ....	129
Figure 19. Comparison of the Number of Fatal Pedestrian Crashes across States (Query Using Injury Severity = 4, Fatal Injury (K) and Person Type = 5, Pedestrian in FARS Data) (173).....	145
Figure 20. All TxDOT-Reportable Traffic and Pedestrian Crashes (2007–2011).....	151
Figure 21. All TxDOT-Reportable Pedestrian Crashes (2007–2011). ....	151
Figure 22. TxDOT-Reportable Pedestrian Crashes by TxDOT District (2007–2011).....	152
Figure 23. Percentage Change in TxDOT-Reportable Pedestrian Crashes by TxDOT District (2007–2011).....	152
Figure 24. TxDOT-Reportable Pedestrian Crashes by Month of Year and Hour of Day and Crash Severity (2007–2011). ....	154
Figure 25. TxDOT-Reportable Pedestrian Crashes by Hour of Day and Month of Year (2007–2011).....	155
Figure 26. TxDOT-Reportable Pedestrian Crashes by Traffic Control and Rural Flag. ....	157
Figure 27. TxDOT-Reportable Pedestrian Crashes by Hour of Day and Light Condition (2007–2011).....	158
Figure 28. TxDOT-Reportable Pedestrian Crashes by Light Condition and Crash Severity. ....	159
Figure 29. TxDOT-Reportable Pedestrian Crashes by Weather Condition, Crash Severity and Rural Flag (2007–2011).....	159
Figure 30. TxDOT-Reportable Pedestrian Crashes by Road Class and Crash Severity (2007–2011).....	160
Figure 31. Distribution of 2011 TxDOT-Reportable Fatal and Injury Crashes in Select TxDOT Districts by Median Width (ft) and Total Number of Lanes.....	162



Figure 32. Distribution of 2011 TxDOT-Reportable Fatal and Injury Crashes in Select TxDOT Districts by Crossing Width to Refuge (ft) and Total Number of Lanes.....	163
Figure 33. Age Group Distribution by Gender in TxDOT-Reportable Pedestrian Crashes (2007–2011).....	167
Figure 34. Ethnicity Distribution in TxDOT-Reportable Pedestrian Crashes (2007–2011). ....	168
Figure 35. Comparison of CRIS and FARS Data for Fatal Pedestrian Crashes (2007–2011). ..	172
Figure 36. Fatal Pedestrian Crashes by Day of Week and Light Condition (2007–2011). ....	175
Figure 37. Fatal Pedestrian Crashes by Hour of Day and Day of Week (2007–2011).....	176
Figure 38. Fatal Pedestrian Crashes by Month of Year (2007–2011). ....	177
Figure 39. Fatal Pedestrian Crashes by Hour of Day and Season/Month of Year (2007–2011).....	178
Figure 40. Fatal Pedestrian Crashes by Road Alignment (2007–2011).....	179
Figure 41. Fatal Pedestrian Crashes by the Hour of Day and Intersection Relation (2007–2011).....	180
Figure 42. Fatal Pedestrian Crashes by Month of Year and Intersection Relation (2007–2011).....	180
Figure 43. Fatal Pedestrian Crashes by Light Condition and Intersection Relation (2007–2011).....	181
Figure 44. Number of Pedestrian Fatalities by TxDOT District and Road Class (2007–2011).....	182
Figure 45. Distribution of Fatal Pedestrian Crashes by Median Width and Total Number of Lanes.....	186
Figure 46. Distribution of Fatal Pedestrian Crashes by Crossing Width to Refuge and Total Number of Lanes. ....	187
Figure 47. Number of Fatal Crash Records by Injury Severity of Those Involved (2007–2011).....	188
Figure 48. Age Group Distribution by Gender of Pedestrian Involved in Fatal Crashes (2007–2011).....	190
Figure 49. Age Group Distribution by Gender – U.S. Census Data for 2010 ().....	191
Figure 50. Ethnicity Distribution of Drivers and Pedestrians Involved in Fatal Pedestrian-Related Crashes (2007–2011).....	191
Figure 51. Ratio of 2010 Fatal Pedestrian-Related Crashes to 2010 Population.....	193
Figure 52. Proportion of 2010 Population 16 Years and above That Walked to Work (176)...	194
Figure 53. Proportion of 2010 Civilian Non-Institutionalized Population with Disability (176).....	195
Figure 54. Number of Households in the 2010 Census Data (176).....	195
Figure 55. Proportion of 2010 Population with High School Education and English Speaking Ability (176). ....	196
Figure 56. Per Capita Income in 2010 Census Data (176). ....	196
Figure 57. Distribution of Fatal TxDOT-Reportable Pedestrian Crashes on Interstates or U.S. and State Highways by Roadway Type and Posted Speed Limit.....	203
Figure 58. Comparison of BAC Test Results (from CRIS Database) of Pedestrians and Drivers Who Were Found to be under the Influence of Alcohol in the Crash Report Review. ....	208

Figure 59. Proportion of Fatal TxDOT-Reportable Pedestrian Crashes on Interstates or U.S. and State Highways by Roadway Type and Unit at Fault in the Officer's Opinion. ....	212
Figure 60. Distribution of Fatal TxDOT-Reportable Pedestrian Crashes on Freeways by Texas Metropolitan Statistical Area. ....	214
Figure 61. Distribution of Fatal TxDOT-Reportable Pedestrian Crashes on 10 Freeways with the Most Crashes by Alcohol/Drug Influence on Pedestrian. ....	215
Figure 62. Classification Tree. ....	234
Figure 63. Right Branch of the Classification Tree. ....	235
Figure 64. Left Branch of the Classification Tree. ....	236

## LIST OF TABLES

	<b>Page</b>
Table 1. Crash Modification Factors for Signalization Countermeasures for Pedestrian Crashes (8).....	10
Table 2. Crash Modification Factors for Geometric Countermeasures for Pedestrian Crashes (8).....	11
Table 3. Crash Modification Factors for Signs, Markings, and Operational Countermeasures for Pedestrian Crashes (8).....	11
Table 4. List of Pedestrian Treatments. ....	17
Table 5. Evaluation of In-Roadway Warning Lights in California (41).....	24
Table 6. Evaluation of In-Roadway Warning Lights in Kirkland, Washington (43). ....	24
Table 7. Driver Yielding at In-Street Installations (54).....	26
Table 8. Evaluation Results on In-Street Pedestrian Crossing Signs.....	28
Table 9. Effectiveness of Pedestrian Treatments at Unsignalized Locations (58). ....	30
Table 10. Baseline and Follow-up Yielding Data at RRFB Sites in Florida, Illinois, and Washington, D.C. (72).....	34
Table 11. Measures of Effectiveness for RRFBs with Pedestrian Crossing Signs, Miami, Florida (75). ....	36
Table 12. Speed Changes Due to Bulbouts (79). ....	42
Table 13. Percent of Motorists Yielding to Pedestrians at Bulbout Crosswalks (93). ....	42
Table 14. Percent of Motorists Stopping for Staged Pedestrians at Bulbout Crosswalks (93).....	43
Table 15. Crash Effects of Providing Sodium Floodlights at Pedestrian Crossings in Perth, Australia (79). ....	43
Table 16. Effects of Crosswalk Illumination on Nighttime Pedestrian Crashes in Israel (79).....	44
Table 17. Results for “Smart Lighting” Pedestrian Safety MOEs (97). ....	45
Table 18. Results for “Smart Lighting” Motorist Safety MOEs (97). ....	45
Table 19. Comparison of Crashes Before and After Installation of Pedestrian Overpasses in Tokyo (79). ....	46
Table 20. Comparison of Vehicle Speeds at Raised Crosswalks (93).....	47
Table 21. Pedestrians at Raised Crosswalks for Whom Motorists Stopped (93). ....	47
Table 22. Pedestrians at Refuge Islands for Whom Motorists Yielded (93). ....	48
Table 23. Drivers Yielding to Pedestrians at Median Refuge Islands (54). ....	49
Table 24. Trapped Pedestrians at Offset Median Openings (54).....	49
Table 25. Drivers Yielding to Pedestrians at Offset Median Openings (54). ....	50
Table 26. Results of EB Analysis on Four-Lane to Three-Lane Road Diets (106). ....	50
Table 27. Minimum and Maximum Funding Allocations for Pedestrian Projects through Texas Safe Routes to School (113).....	71
Table 28. Intersection-Related Pedestrian Safety Issues. ....	87
Table 29. Pedestrian Safety Issues at Non-Intersection Locations. ....	87
Table 30. Other Pedestrian-Related Safety Problems Not Listed in Question 1. ....	88
Table 31. Pedestrian-Related Engineering Safety Treatments Used by Respondents. ....	89
Table 32. Pedestrian-Related Enforcement Safety Treatments Used by Respondents. ....	89
Table 33. Pedestrian-Related Education Safety Treatments Used by Respondents. ....	90

Table 34. Distribution of Study Sites by Treatment, Posted Speed Limit, Number of Lanes, and One-Way or Two-Way Traffic. ....	97
Table 35. Pedestrian Hybrid Beacon Sites.....	98
Table 36. Rectangular Rapid-Flashing Beacon Sites.....	99
Table 37. Traffic Control Signal Sites. ....	99
Table 38. Results from Preliminary Logistic Model Where the Baseline Treatment Is PHB. ...	106
Table 39. Average Driver Yielding by Treatment. ....	107
Table 40. All Data Model Results Focusing on Treatments. ....	108
Table 41. Average Driver Yielding by Treatment and City. ....	109
Table 42. PHB Total Driver Yielding Model Results Using Total Crossing Distance. ....	111
Table 43. PHB Total Driver Yielding Model Results Using Number of Lanes and Median Type. ....	113
Table 44. RRFB Total Driver Yielding Model Results. ....	114
Table 45. Average Driver Yielding by Posted Speed Limit for RRFB Sites. ....	115
Table 46. Average Driver Yielding by One-Way or Two-Way Traffic for RRFB Sites.....	116
Table 47. PHB Nearside Yielding Model Results Using Number of Lanes and Median Type. ....	118
Table 48. PHB Farside Yielding Model Results Using Number of Lanes and Median Type....	119
Table 49. PHB Average Driver Yielding by Median Treatment and One-Way/Two-Way Traffic. ....	119
Table 50. PHB Average Driver Yielding by One-Way/Two-Way Traffic and Number of Lanes.....	120
Table 51. RRFB Nearside Driver Yielding Model Results Using Crossing Distance and Location of Beacons for Garland Sites. ....	121
Table 52. RRFB Farside Driver Yielding Model Results Using Crossing Distance and Location of Beacons for Garland Sites. ....	122
Table 53. PHB Total Driver Yielding Model Results Using Time since Installation for Austin Sites with Four or More Lanes.....	124
Table 54. Predicted Driver Yielding Rate a Year or Two Years After Installation.....	124
Table 55. RRFB Driver Yielding Model Results Using Time since Installation for Garland Sites with Four or More Lanes. ....	125
Table 56. Study Site Characteristics. ....	130
Table 57. Data Overview for Study Sites. ....	131
Table 58. Driver Yielding at Before-and-After Study Sites. ....	133
Table 59. Driver Yielding to Staged Crossings at Before-and-After Study Sites. ....	134
Table 60. Number of Pedestrian Crossings at Before-and-After Study Sites.....	136
Table 61. Non-Staged and Jaywalking Crossings per Hour at Before-and-After Study Sites. ..	137
Table 62. Non-Staged Pedestrian Activation at Treated Study Sites.....	138
Table 63. Active Use of Electronics by Non-Staged Pedestrian at Treated Study Sites. ....	139
Table 64. Non-Staged Pedestrian Waiting Position at Treated Study Sites. ....	139
Table 65. Nearside Yielding by Non-Staged Pedestrian Waiting Position. ....	140
Table 66. Non-Staged Pedestrian Searching Behavior at Treated Study Sites.....	140
Table 67. Non-Staged Pedestrian Searching Behavior at Treated Study Sites by Presence of Crossing Guard. ....	141
Table 68. Non-Staged Pedestrian Starting Behavior at Treated Study Sites. ....	142
Table 69. Non-Staged Pedestrian Crossing Mode at Treated Study Sites.....	142

Table 70. Assistive Apparatus Used by Non-Staged Pedestrians.....	143
Table 71. Non-Staged Pedestrian Behavior Approaching Second Lane at Treated Study Sites.....	143
Table 72. Number of Non-Staged Pedestrians in Each Crossing Maneuver at Treated Study Sites.....	144
Table 73. Number of Records by Harmful Event Code.....	147
Table 74. Number of Records for Pedestrians in Person and Unit Files. ....	148
Table 75. Pedestrian Crashes as a Percentage of all Texas Traffic Crashes, by Severity .....	148
Table 76. Geometric Information at a Crash Location Obtained from Aerial Photographs. ....	149
Table 77. Summary of 2011 Crashes in the Extended Geometric Database by CRIS Road Class, TxDOT District, and Severity.....	150
Table 78. Number of TxDOT-Reportable Pedestrian Crashes by Severity and TxDOT District (2007–2011).....	153
Table 79. TxDOT-Reportable Pedestrian Crashes by Severity and Rural Flag (2007–2011)....	155
Table 80. Number of TxDOT-Reportable Pedestrian Crashes (KABCO) with Respect to Proximity to an Intersection.....	156
Table 81. Number of TxDOT-Reportable Pedestrian Crashes (KABCO) by Location. ....	156
Table 82. Distribution of 2011 TxDOT-Reportable Fatal and Injury Crashes in Select TxDOT Districts by the Functional Class Identified From Aerial Photographs. ....	160
Table 83. Distribution of 2011 TxDOT-Reportable Fatal and Injury Crashes in Select TxDOT Districts by Presence of Roadway Lighting and a Sidewalk. ....	161
Table 84. Distribution of 2011 TxDOT-Reportable Fatal and Injury Crashes in Select TxDOT Districts by Total Number of Lanes and Number of Left-Turn Lanes. ....	161
Table 85. Distribution of 2011 TxDOT-Reportable Fatal and Injury Crashes in Select TxDOT Districts by Median Type and Median Width.....	162
Table 86. Distribution of 2011 TxDOT-Reportable Fatal and Injury Crashes in Select TxDOT Districts by Posted Speed Limit (mph) and Total Number of Lanes.....	163
Table 87. Distribution of 2011 TxDOT-Reportable Fatal and Injury Crashes in Select TxDOT Districts By Crash Location and Traffic Control Type.....	164
Table 88. Number of TxDOT-Reportable Pedestrian Crash Records by Person Occupant Position. ....	164
Table 89. Number of TxDOT-Reportable Pedestrian Crash Records by Person Type. ....	166
Table 90. Alcohol Test Result of Drivers and Pedestrians Involved in TxDOT-Reportable Pedestrian Crashes (2007–2011). ....	169
Table 91. Fatal Crashes by Year and TxDOT-Reportable Flag (2007–2011).....	171
Table 92. Number of Fatal Pedestrian TxDOT-Reportable Crash Records by Harmful Event Code.....	172
Table 93. Number of Fatal Crash Records by Manner of Collision. ....	173
Table 94. Number of Fatal Crash Records by Weather Condition and Light Condition.....	174
Table 95. Fatal Pedestrian Crashes by Roadway and Intersection Relation. ....	179
Table 96. Fatal Pedestrian Crashes by Road Class and Road Part. ....	181
Table 97. Fatal Pedestrian Crashes by Functional System and Number of Lanes. ....	183
Table 98. Fatal Pedestrian Crashes by Number of Lanes and Right Shoulder Width. ....	184
Table 99. Fatal Pedestrian Crashes by Median Type and Median Width.....	184
Table 100. Distribution of Fatal Pedestrian Crashes by Crash Location and Traffic Control Type. ....	185

Table 101. Distribution of Fatal Pedestrian Crashes by Presence of Sidewalk and Presence of Roadway Lighting. ....	185
Table 102. Distribution of Fatal Pedestrian Crashes by Median Type and Median Width. ....	186
Table 103. Distribution of Fatal Pedestrian Crashes by Total Number of Lanes and Number of Left-Turn Lanes.....	187
Table 104. Number of Fatal Crash Records by Person Occupant Position. ....	188
Table 105. Age Distribution of Pedestrians Killed in Fatal Pedestrian-Related Crashes. ....	189
Table 106. Alcohol Test Result of Drivers and Pedestrians Involved in Fatal Pedestrian Crashes (2007–2011). ....	192
Table 107. BAC Test Result of Drivers and Pedestrians Involved in Fatal Pedestrian Crashes (2007–2011). ....	192
Table 108. Drug Test Result of Drivers and Pedestrians Involved in Fatal Pedestrian Crashes (2007–2011). ....	192
Table 109. Summary of Fatal Pedestrian Crashes in Texas in Comparison with National Data (175). ....	197
Table 110. State Ranking of Interstate Highway Pedestrian Fatalities per 100 Million Interstate Vehicle-Miles Traveled, 2007–2011. ....	200
Table 111. Reason for Exclusion from Analysis. ....	201
Table 112. Information Extracted from Crash Narratives. ....	202
Table 113. Distribution of Fatal TxDOT-Reportable Pedestrian Crashes by CRIS Road Class and Roadway Type (2007–2011). ....	203
Table 114. Distribution of Fatal TxDOT-Reportable Pedestrian Crashes on Interstates or U.S. and State Highways by Road Part and Roadway Type. ....	204
Table 115. Distribution of Fatal TxDOT-Reportable Pedestrian Crashes on Interstates or U.S. and State Highways by Person Type and Roadway Type. ....	204
Table 116. Age Distribution of Fatality Rate (Fatal TxDOT-Reportable Pedestrian Crashes on Freeways Per 100,000 Population) Per Year.....	205
Table 117. Gender Distribution of Fatality Rate (Fatal TxDOT-Reportable Pedestrian Crashes on Freeways Per 100,000 Population) Per Year. ....	206
Table 118. Ethnicity Distribution of Fatality Rate (Fatal TxDOT-Reportable Pedestrian Crashes on Freeways Per 100,000 Population) Per Year. ....	206
Table 119. Distribution of Pedestrians and Drivers under the Influence of Alcohol/Drug in TxDOT-Reportable Fatal Pedestrian Crashes on Freeways. ....	207
Table 120. Distribution of Fatal TxDOT-Reportable Pedestrian Crashes (on CRIS Road Class 1 or 2) by Roadway Type and Pedestrian Action prior to Crash. ....	209
Table 121. Distribution of Fatal TxDOT-Reportable Pedestrian Crashes (on CRIS Road Class 1 or 2) on Roadway Type Freeway by Road Part and Pedestrian Action prior to Crash. ....	209
Table 122. Distribution of Fatal TxDOT-Reportable Pedestrian Crashes (on CRIS Road Class 1 or 2) by Reason for Pedestrian at Crash Location (as Related to a Vehicle) and Roadway Type. ....	210
Table 123. Distribution of Fatal TxDOT-Reportable Pedestrian Crashes (on CRIS Road Class 1 or 2) by Reason for Pedestrian at Crash Location and Roadway Type. ....	211
Table 124. Distribution of Fatal TxDOT-Reportable Pedestrian Crashes (on CRIS Road Class 1 or 2) on Roadway Type Freeway due to a Stalled Vehicle or a Previous Crash by Road Part and Pedestrian Action prior to Crash.....	212

Table 125. Distribution of Fatal TxDOT-Reportable Pedestrian Crashes on Freeways by Weather Condition and Light Condition. ....	213
Table 126. Distribution of Fatal TxDOT-Reportable Pedestrian Crashes on 10 Freeways with the Most Crashes by Texas Metropolitan Statistical Area. ....	214
Table 127. Distribution of Crashes Per 100 Miles on 10 Freeways with the Most Fatal TxDOT-Reportable Pedestrian Crashes in Texas. ....	215
Table 128. Variables Used in Analysis. ....	222
Table 129. Prediction Performance for the CRT Model. ....	230
Table 130. Misclassification Costs for the CRT Model. ....	231
Table 131. Risk Estimate of the Model. ....	231
Table 132. Model Summary. ....	232
Table 133. Independent Variable Importance. ....	233





# CHAPTER 1

## INTRODUCTION

For Texas, the average number of pedestrian fatalities over the most recent 5-year period available (2007–2011) is about 400 per year. Texas is considered by the Federal Highway Administration (FHWA) to be a “focus” state due to the high number of pedestrian crashes. This Texas Department of Transportation (TxDOT) project assisted the state with identifying characteristics of Texas pedestrian crashes and countermeasures to address those crashes.

### RESEARCH OBJECTIVES

The objectives of the Texas Department of Transportation Project 0-6702 are as follows:

- Identify characteristics of pedestrian crashes in Texas.
- Identify potential safety treatments or combinations of treatments that reduce pedestrian fatalities and injuries.
- Evaluate selected pedestrian treatments.
- Document findings.

### REPORT ORGANIZATION

This report has 13 chapters.

- **Chapter 1 Introduction** – describes the objective of the project and the report organization.
- **Chapter 2 Literature Review – Pedestrian Characteristics** – includes a summary of pedestrian characteristics such as pedestrian walking speed.
- **Chapter 3 Literature Review – Safety Evaluations** – includes a summary of previous research on factors contributing to pedestrian crashes, pedestrian crash type, and predicting pedestrian crashes, and a description of the systematic safety selection tool.
- **Chapter 4 Literature Review – Treatments** – includes a summary of previous research in the areas of engineering, education, and enforcement.
- **Chapter 5 Funding Opportunities for Pedestrian Safety Improvements** – includes a summary of the funding opportunities that are available from federal, state, and non-profit organizations for pedestrian safety.
- **Chapter 6 Questionnaire on Pedestrian Safety Treatments** – summarizes the responses received to a questionnaire. To understand the Texas environment related to the installation of pedestrian safety treatments, the research team asked for practitioners’ (in TxDOT districts, cities, and metropolitan planning organizations [MPOs] in each of the major metropolitan areas) opinions about current issues that they are facing with respect to pedestrian safety, choice of pedestrian safety treatments, and future needs to make more informed decisions on pedestrian treatments.
- **Chapter 7 Examination of the Relationship between Roadway Characteristics and Driver Yielding to Pedestrians** – identifies roadway characteristics that are associated with improved driver yielding at pedestrian crossings. Several traffic control devices are

used at pedestrian crossings to improve conditions for crossing pedestrians including traffic control signal (TCS), pedestrian hybrid beacon (PHB), and rectangular rapid-flashing beacon (RRFB).

- **Chapter 8 Pedestrian and Driver Behavior Before and After Installation of Pedestrian Treatments** – discusses research that demonstrates the positive effects of treatments at selected sites. Specific crosswalk sites in Texas were treated with pedestrian hybrid beacons and rectangular rapid-flashing beacons during this research project.
- **Chapter 9 In-Depth Review of Texas Pedestrian Crashes** – analyzes the crash and person characteristics of 36,420 TxDOT-reportable pedestrian crashes identified in the TxDOT Crash Record Information System (CRIS) database (2007–2011) and geometric characteristics (identified using aerial photographs) for 1,554 TxDOT-reportable fatal and injury pedestrian crashes that occurred in Austin, Bryan, Corpus Christi, Laredo, and San Antonio TxDOT districts (2011).
- **Chapter 10 In-Depth Review of Texas Fatal Pedestrian Crashes** – analyzes the crash, person, roadway, and socioeconomic characteristics of 2,232 TxDOT-reportable fatal pedestrian crashes identified in the TxDOT CRIS database and geometric characteristics for 2,203 TxDOT-reportable fatal pedestrian crashes identified using aerial photographs (2007–2011).
- **Chapter 11 Review of Fatal Pedestrian Crashes on High-Speed Roads in Texas** – analyzes characteristics of 1160 TxDOT-reportable pedestrian crashes on high-speed roadways (i.e., Interstates or U.S. and State highways) identified in the TxDOT CRIS database (2007–2011).
- **Chapter 12 Analysis of Texas Pedestrian Crashes Using Classification Tree Models** – identifies the significant factors associated with Texas pedestrian crashes, using classification tree models.
- **Chapter 13 Summary and Conclusions** – provides the summary and key findings from each study along with the conclusions from the research.

## CHAPTER 2

### LITERATURE REVIEW – PEDESTRIAN CHARACTERISTICS

#### PEDESTRIANS

At some point during a trip, all roadway users become pedestrians; this indicates pedestrian characteristics are as diverse as a community's population. Pedestrian characteristics that influence facility needs are (1):

- Reasons for walking or not walking.
- Settings (urban versus rural).
- Pedestrian walking speed.
- Pedestrian space requirements.
- Pedestrian age.

#### Reasons for Walking or Not Walking

Trip distance, perceived safety, comfort, and convenience as compared to an alternative mode influence the decision to take a trip by walking or not walking (1). Most pedestrian trips (73 percent) are less than 0.5 mile, and 1 mile tends to be the maximum length of a walking trip. Sidewalk presence and location, intimidating crossings, excessive crossing distances, or fast-turning vehicles influence pedestrians' perceived safety. Characteristics of the built environment such as trees, buildings, places to sit, and landscaping enhance the comfort and convenience of walking. Some of the reasons for people making walking trips are:

- To and from work and school.
- Social visits and events.
- Appointments.
- Health and exercise.
- Errands and deliveries.
- Recreation.
- Extracurricular activities.
- Combined (recreation walking while shopping).
- Multimodal trips (walking to bus stop).

Common reasons for people choosing not to make a trip by walking are (1):

- Poor facilities or lack of sidewalks or walkways.
- Failure to provide a contiguous system of pedestrian facilities.
- Concerns for personal safety.
- Failure to provide facilities to and from popular origins and destinations.
- Inclement weather.
- Poor lighting.
- Lack of facilities separated from the roadway.

## **Settings (Urban versus Rural)**

Nationally, walking trips are more common in urban areas. Heavy traffic volumes, limited parking, and/or expensive parking make walking trips seem like the easier, faster, and cheaper choice (1). Additionally, urban areas are more likely to have transit systems and facilities that promote pedestrian activities. Further reasons for walking trips being more common in urban areas are:

- Traffic congestion is high.
- Origin and destination points are more numerous and denser in concentration.
- Shopping and services are more accessible to pedestrians.
- Average trip distances are shorter.
- Parking is too costly or unavailable.
- Transit service is more readily available.
- More pedestrian facilities are available.

People who make suburban and rural trips are often walking to school, walking to school bus stops, walking to transit bus stops, walking for recreation, and/or walking for leisure.

## **Pedestrian Walking Speed**

The 2009 Manual on Uniform Traffic Control Devices (MUTCD) (2) includes a pedestrian walking speed of 3.5 ft/s, which is less than the previous speed of 4.0 ft/s. In addition to the lower pedestrian speed of 3.5 ft/s, the guidance also includes a provision to reduce the speed further if pedestrians in the area walk slower. Other studies (1) have indicated that walking speeds can range from 2.0 to 4.3 ft/s. Populations that may require slower pedestrian speeds are:

- Children.
- Older pedestrians.
- Persons with disabilities.

## **Pedestrian Space Requirements**

Pedestrian space requirements are three-dimensional; pedestrian width, pedestrian height, and preferred forward clearance all play a role (1). On average, two pedestrians walking together take up 4.7 ft of sidewalk width; the minimum width to serve two pedestrians passing each other is 6 ft. For pedestrians with sight impairments, objects should be above the pedestrians' ability to reach them with their hands. The preferred forward clearance is the pedestrian spatial bubble, and it varies by circumstance. Some examples are:

- Public events, 6 ft.
- Shopping, 9 to 12 ft.
- Normal walking, 15 to 18 ft.
- Pleasure walking, 35 ft or more.

## **Pedestrian Age**

While they act differently, the characteristics of both child pedestrians and older pedestrians suggest particular concerns for roadway designers (1). Children often have problems with risk perception, attention, and impulsiveness. Conversely, older pedestrians do not have these problems; they often have physical conditions limiting their abilities to assess traffic situations. Some of the things children have difficulty with are:

- Seeing and evaluating the entire traffic situation correctly because of their height.
- Processing information in peripheral vision, accompanied by poor visual acuity until about the age of 10 years.
- Distributing their attention (being easily preoccupied or distracted).
- Discriminating between right and left.
- Correctly perceiving the direction of sound and the speed of vehicles.
- Understanding the use of traffic control devices and crosswalks.
- Judging distances of cars and when a safe gap occurs between vehicles.

In addition to these difficulties, children also have beliefs that put them at risk. Those beliefs include:

- The safest way to cross the street is to run.
- It is safe to cross against the red light.
- Adults will always be kind to them, so drivers will be able to stop instantly if they are in danger.

Some of the characteristics of older pedestrians that put them at risk are:

- Vision is affected in older people by decreased acuity and visual field, loss of contrast sensitivity, and slower horizontal eye movement.
- They often have difficulty with balance and postural stability, resulting in slower walking speeds and increased chances for tripping.
- Selective attention mechanism and multi-tasking skills become less effective with age, so older people may have difficulty locating task-relevant information in a complex environment.
- They have difficulty in selecting safe crossing situations in continuously changing complex traffic situations, likely because of deficits in perception and cognitive abilities, as well as ineffectual visual scanning, limitations in time-sharing, and inability to ignore irrelevant stimuli.
- They have difficulty in assessing the speed of approaching vehicles, thus misjudging when it is safe to cross the road.
- They have slower reaction time and decision-making.
- Those with arthritis may have restricted head and neck mobility as well as difficulty walking.
- There is reduced agility for those who use canes or crutches for assistance.

## **FACILITY PREFERENCES**

Based upon various user characteristics and pedestrian perception data, the most recent version of the Highway Capacity Manual (HCM) provides an updated method for evaluating urban street service to pedestrians (3). The HCM assumes that the following characteristics affect service to pedestrians:

- Effective sidewalk width.
- Pedestrian flow rate.
- Pedestrian intersection delay.
- Occupied on-street parking.
- Buffer width.
- Mid-segment demand flow rate (motorized vehicle).
- Number of through lanes.
- Running speed of motorized vehicles.
- Distance between pedestrian crossings.
- Pedestrian walking speed.

These characteristics define service to pedestrians within the context of three concepts (3). The first concept is level of service (LOS), which is the pedestrian's perception of the overall facility. The second is the average pedestrian speed, with slower speeds indicating lower service quality. The third concept is circulation area, which indicates the amount of sidewalk area available to each pedestrian using the facility. Based upon research evidence, the HCM assumes that improving service within these three concepts provides a better experience for pedestrians.

## **SUMMARY**

Design of a pedestrian facility depends on a number of user characteristics: reasons for walking or not walking, settings (urban versus rural), pedestrian walking speed, pedestrian space requirements, and pedestrian age. The quality of service of such facilities can be measured (as per the Highway Capacity Manual) in terms of effective sidewalk width, pedestrian flow rate, pedestrian intersection delay, occupied on-street parking, buffer width, mid-segment demand flow rate (motorized vehicle), number of through lanes, running speed of motorized vehicles, distance between pedestrian crossings, and pedestrian walking speed.

## CHAPTER 3

### LITERATURE REVIEW – SAFETY EVALUATIONS

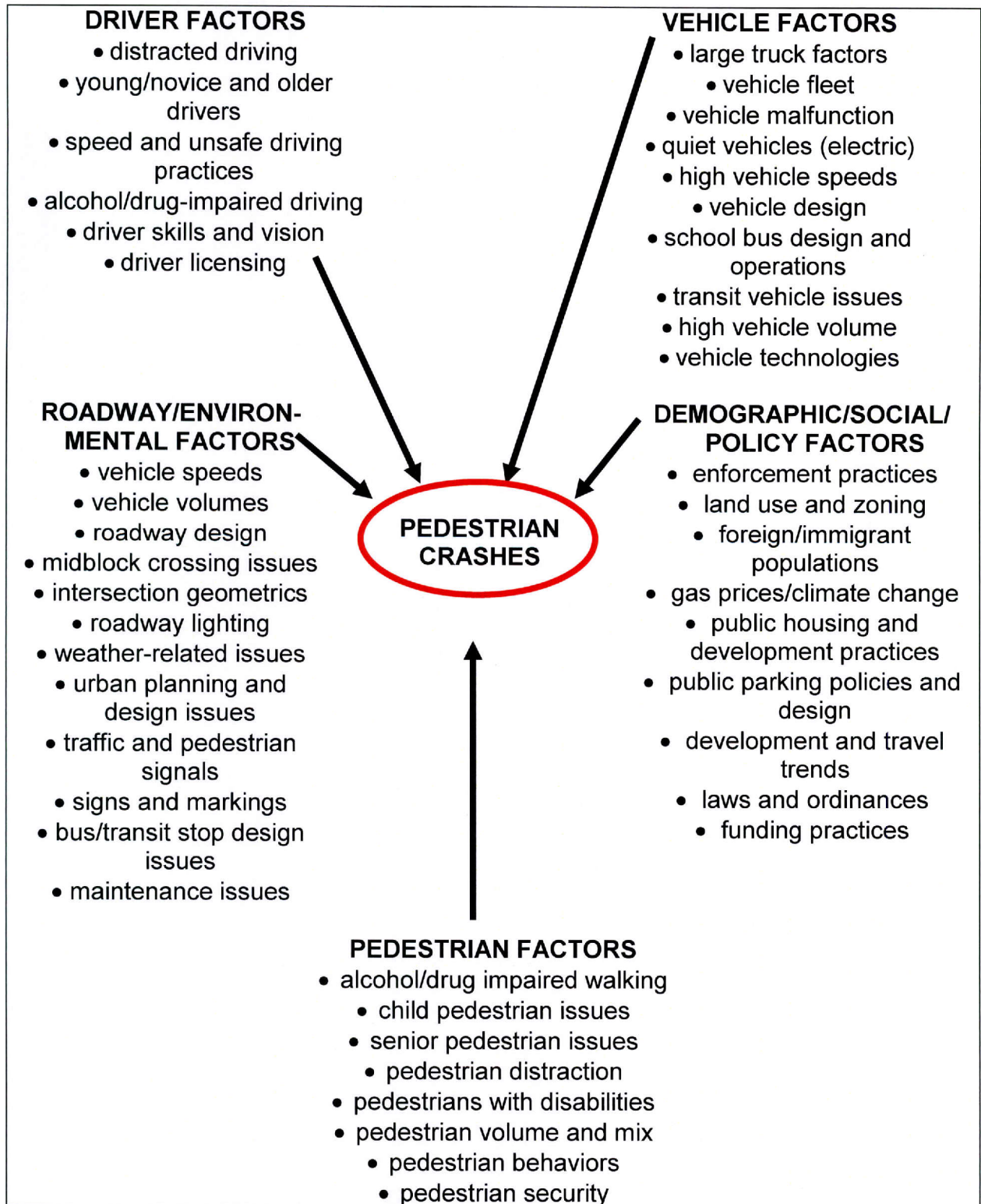
#### FACTORS CONTRIBUTING TO PEDESTRIAN CRASHES

Along with the variability in pedestrian characteristics described in Chapter 2, many factors contribute to pedestrian crashes. The factors contributing to pedestrian crashes can be divided into five categories. Those categories are demographic/social/policy factors, driver factors, pedestrian factors, roadway/environmental factors, and vehicle factors (4). Some of the key characteristics of each of these factors are shown in Figure 1.

#### PEDESTRIAN CRASH TYPES

In addition to the categories of contributing factors, past research has defined various crash types. Volume 10 of the National Cooperative Highway Research Program (NCHRP) Research Report 500 contains definitions of 12 pedestrian crash types (5). Those definitions are:

- **Midblock: Dart/Dash** – The pedestrian walked or ran into the roadway and was struck by a vehicle. The motorist's view of the pedestrian may have been blocked until an instant before the impact, and/or the motorist may have been speeding.
- **Multiple Threat** – The pedestrian entered the traffic lane in front of stopped traffic and was struck by a vehicle in an adjacent lane traveling in the same direction as the stopped vehicle. The stopped vehicle may have blocked the sight distance between the pedestrian and the striking vehicle, and/or the motorist may have been speeding.
- **Mailbox or Other Midblock** – The pedestrian was struck while getting into or out of a stopped vehicle or while crossing the road to/from a mailbox, newspaper box, ice-cream truck, etc.
- **Failure to Yield at Unsignalized Location** – At an unsignalized intersection or midblock location, a pedestrian stepped into the roadway and was struck by a vehicle. The motorist failed to yield to the pedestrian and/or the pedestrian stepped directly into the path of the oncoming vehicle.
- **Bus Related** – The pedestrian was struck by a vehicle while (a) crossing in front of a commercial bus—or school bus—stopped at a bus stop, (b) going to or from a school bus stop, or (c) going to or from or waiting near a commercial bus stop.
- **Turning Vehicle at Intersection** – The pedestrian was attempting to cross at an intersection and was struck by a vehicle that was turning right or left.
- **Through Vehicle at Intersection** – The pedestrian was struck at a signalized or unsignalized intersection by a vehicle that was traveling straight ahead.
- **Walking Along Roadway** – The pedestrian was walking or running along the roadway and was struck from the front or from behind by a vehicle.
- **Working/Playing in Road** – A vehicle struck a pedestrian who was (a) standing or walking near a disabled vehicle, (b) riding a play vehicle that was not a bicycle (e.g., wagon, sled, tricycle, skates), (c) playing in the road, or (d) working in the road.



**Figure 1. Illustration of Factors Associated with Pedestrian Crash Risk and/or Severity (Zegeer and Bushell, Accident Analysis and Prevention 2012) (4).**



- **Not in Road (Driveway, Parking Lot, Sidewalk, or Other)** – The pedestrian was standing or walking near the roadway edge, on the sidewalk, in a driveway or alley, or in a parking lot when struck by a vehicle.
- **Backing Vehicle** – The pedestrian was struck by a backing vehicle on a street, in a driveway, on a sidewalk, in a parking lot, or at another location.
- **Crossing an Expressway** – Pedestrian was struck while crossing a limited-access expressway or expressway ramp.

## PREDICTING PEDESTRIAN CRASHES

In the predictive method for urban and suburban arterials found in the *Highway Safety Manual* (HSM) 1st Edition (6), the methodology for predicting pedestrian crashes uses modification factors (much like those used in the Highway Capacity Manual); this is not always the method for predicting these types of crashes for other roadway types, such as two-lane rural highways. First, the urban/suburban arterial methodology predicts non-pedestrian, non-bicycle crashes; then the modification value is applied. The predicted frequency of crashes not including bicycles and pedestrians is calculated for multi-vehicle driveway, single-vehicle, and multi-vehicle non-driveway crashes.

The pedestrian crash adjustment factors are available for five roadway types:

- Two-lane undivided arterials.
- Three-lane with two-way left-turn lane (TWLTL) arterials.
- Four-lane undivided arterials.
- Four-lane divided arterials.
- Five-lane with TWLTL arterials.

Additionally, these road types are subdivided by posted speed limit. For speed limits 30 mph or lower, the factors range from 0.022 to 0.067. For speed limits 35 mph or greater, the values range from 0.005 to 0.023. The values are available on pages 12–27 of the HSM.

In other chapters, the HSM predicts pedestrian crashes using default crash distributions. For example, in the default crash distributions, vehicle-pedestrian crashes are 0.3 percent of all crashes on rural two-lane, two-way roadways. The HSM recommends states determine default percentages using crash data collected in their state.

## CRASH MODIFICATION FACTORS

To advise practitioners on the use of pedestrian countermeasures to reduce pedestrian crashes, several recent efforts have gathered information about pedestrian safety and potential crash reduction factors. For example, the FHWA Crash Modification Factors Clearinghouse website (7) lists pedestrian-related crash reduction factors (CRFs)/crash modification factors (CMFs).

A 2013 issue brief (8) provided estimates of the crash reduction that might be expected if specific countermeasures or a group of countermeasures is implemented with respect to pedestrian crashes. The crash reduction estimates are presented as CMFs. A CMF is the proportion of crashes that is expected to remain after the countermeasure is implemented. For

example, an expected 20 percent reduction in crashes would correspond to a CMF of  $(1-0.20) = 0.80$ . Table 1 provides the values for signalized countermeasures, Table 2 for geometric countermeasures, and Table 3 for signs, markings, and operational countermeasures. As noted in the FHWA issue brief, a CMF should be regarded as a generic estimate of the effectiveness of a countermeasure. The estimate is a useful guide, but it remains necessary to apply engineering judgment and to consider site-specific environmental, traffic volume, traffic mix, geometric, and operational conditions, which will affect the safety impact of a countermeasure. Actual effectiveness will vary from site to site. The user must ensure that a countermeasure applies to the particular conditions being considered. An additional caution is that all of these CMFs are for pedestrian crossings of roadways. No CMF was identified for pedestrian crossing treatments of rail.

**Table 1. Crash Modification Factors for Signalization Countermeasures for Pedestrian Crashes (8).**

Countermeasure(s)	Crash Severity	CMF <sup>1</sup> – All Crashes	CMF <sup>1</sup> – Left-Turn Crashes	CMF <sup>1</sup> – Pedestrian
Add exclusive pedestrian phasing	All			0.65 [0.16] (9)
Improve signal timing to intervals specified by the Institute of Transportation Engineers (ITE) <i>Determining Vehicle Change Intervals: A Proposed Recommended Practice, 1985 (10)</i>	Fatal/ Injury			0.68 (11)
Replace existing WALK/DON'T WALK signals with pedestrian countdown signal heads <sup>2</sup>	All			0.75 (12)
Modify signal phasing (implement a leading pedestrian interval)	All			0.95 (13)
Remove unwarranted signals (one-way street)	All			0.83 (14)
Convert permissive or permissive/protected only left-turn phasing	All		0.01 (15)	
Convert permissive or permissive/protected left-turn phasing	All	0.83 [0.07] (9)	0.84 (15)	0.57 [0.22] (9)
Pedestrian hybrid beacon	All	0.71 (16)		0.31 (16)
Increase pedestrian crossing time	All			0.49 [0.10] (17)
Add new traffic signals when warranted	All	0.75 [0.07] (17)		

<sup>1</sup> CMF [standard error] (reference). CMF is a crash modification factor, which is an estimate of the proportion of crashes expected to result after implementing a given countermeasure. Standard error is provided in brackets [ ] when known. Reference is shown in parentheses ( ) for the source information.

<sup>2</sup> Countdown pedestrian signals are now a requirement for all new pedestrian signal installations, according to Part 4 of the 2009 MUTCD.

**Table 2. Crash Modification Factors for Geometric Countermeasures for Pedestrian Crashes (8).**

Countermeasure(s)	Crash Severity	CMF <sup>1</sup> – All Crashes	CMF <sup>1</sup> – Pedestrian
Convert unsignalized intersection to roundabout	Fatal/Injury		0.73 (18)
Install pedestrian overpass/underpass	Fatal/Injury		0.10 (19)
	All		0.14 (19)
Install pedestrian overpass/underpass (unsignalized intersection)	All		0.87 (13)
Install raised median	All		0.75 (19)
Install raised median (marked crosswalk) at unsignalized intersection	All		0.54 (20)
Install raised median (unmarked crosswalk) at unsignalized intersection	All		0.61 (20)
Install raised pedestrian crossing	All	0.70 (21)	
	Fatal/Injury	0.64 (21)	
Install refuge islands	All		0.44 (13)
Install sidewalk (to avoid walking along roadway) <sup>2</sup>	All		0.12 (22)
Provide paved shoulder (of at least 4 feet) <sup>2</sup>	All		0.29 (19)
Narrow roadway cross section from four lanes to three lanes (two through lanes with center turn lane)	All	0.71 (15)	

<sup>1</sup> CMF [standard error] (reference). CMF is a crash modification factor, which is an estimate of the proportion of crashes expected to result after implementing a given countermeasure. Standard error is provided in brackets [ ] when known. Reference is shown in parentheses ( ) for the source information.

<sup>2</sup> This only applies to “walking along the roadway” type crashes.

**Table 3. Crash Modification Factors for Signs, Markings, and Operational Countermeasures for Pedestrian Crashes (8).**

Countermeasure(s)	Crash Severity	CMF <sup>1</sup> – All Crashes	CMF <sup>1</sup> – Pedestrian
Add intersection lighting <sup>2</sup>	Injury	0.73 (15)	
	All	0.79 (15)	
Add segment lighting <sup>2</sup>	Injury	0.77 (15)	
	All	0.80 (15)	
Improve pavement friction (skid treatment with overlay)	Fatal/Injury		0.97 (19)
Increase enforcement <sup>3</sup>	All		0.77 (23)
Prohibit right-turn-on-red	All	0.97 (15)	
Prohibit left turns	All		0.90 (19)
Restrict parking near intersections (to off-street)	All		0.70 (19)
High-visibility crosswalk	All		0.52 [0.17] (9)
High-visibility crosswalk in school zones	All		0.63 [0.12] (24)

<sup>1</sup> CMF [standard error] (reference). CMF is a crash modification factor, which is an estimate of the proportion of crashes expected to result after implementing a given countermeasure. Standard error is provided in brackets [ ] when known. Reference is shown in parentheses ( ) for the source information.

<sup>2</sup> This applies to nighttime crashes only.

<sup>3</sup> This applies to crash reduction on corridors where sustained enforcement is used related to driver yielding in marked crosswalk combined with a public education campaign.

## SYSTEMATIC SAFETY SELECTION TOOL

The traditional approach to addressing safety concerns is location based, where crash patterns are identified, studied, and addressed for a specific intersection, midblock, or even corridor. These locations typically have been chosen due to high crash frequency. With motor vehicle crashes in urban settings, this approach is reasonable since the frequency of crashes can be relatively high.

In rural settings, or when addressing safety for particular modes of transportation such as walking or bicycling, the frequency of crashes is often low, which means that crashes are more difficult to isolate. Severe crashes might occur but in seemingly random locations and circumstances. The systematic approach provides agencies an alternative method to address these crash types and fulfill a previously unmet need.

The Federal Highway Administration has developed a tool that considers pedestrian crashes and targeted solutions (25). The tool, named the “Systemic Safety Project Selection Tool” by its creators, presents a step-by-step process to conduct systematic safety planning to identify highway safety improvement projects for widespread implementation on a particular system of road. Example crash types include roadway departure crashes, head-on crashes, and crashes involving vulnerable road users. The systematic approach involves modifications that are widely implemented to address roadway features correlated with severe crash types.

The systematic approach itself is not a tool but a process that uses risk to drive action. There are three components: planning, balance of funding, and evaluation.

These components are intended to be iterative and easy to apply to a variety of systems, locations, and crash types (26). Within the planning component there are four steps, as follows:

1. Identify crash types and risk factors.
2. Screen and prioritize locations.
3. Select appropriate countermeasures.
4. Prioritize projects.

These steps require a data management component, which is a collection of processes to facilitate data renewal and integration. System-wide crash analysis is required for identifying target crash types and risk factors. Questions to be asked include where are the crashes located, what is the geometry, and what is the behavior of the pedestrian? Doing a risk assessment is necessary so that the analyst is able to identify candidate locations that are more at risk than others. Countermeasures should be low cost so that their implementation can be widespread, stretching the dollars as far as possible across the study area. Therefore, selecting low-cost solutions having the most benefit will likely offer the most rewards, and will provide a balance of funding for the second component of the systematic approach.

One main advantage of the systematic safety program is that projects that would not normally compete for funding have a better chance. The Highway Safety Improvement Program (HSIP) is one of those funding categories where pedestrian projects in particular have not been selected due to low ranking. Like projects on rural and local roadways, pedestrian projects can better compete for funding when they are selected as part of the systematic safety process.

The final step of the systematic safety process is evaluating the effectiveness. Both output (funding-level decisions) and outcomes (program-level trends, treated facilities only, cost effectiveness, and countermeasure performance) should be included in this evaluation.

The systematic approach does not replace the approach to address safety at high crash locations. Instead, it is a complementary approach that offers another decision-making process. If there are

only a few crashes at apparent random locations of a similar crash type, a systematic approach might be more appropriate.

### **MnDOT Example**

The Minnesota Department of Transportation (MnDOT) is using the systematic approach in its efforts to address safety. MnDOT first applied the approach to its county road safety plans. In its rural counties, road departure crashes were the biggest problem, while in its metropolitan counties, there were high pedestrian and bicyclist crashes. However, there was no one place where these crashes accumulated. MnDOT personnel looked at the characteristics of the crashes and places with similar characteristics instead of chasing a few locations where two to three severe crashes occurred in a year. They used the Minnesota Crash Mapping Analysis Tool to assist them in this process.

In their urban areas, they found that 87 percent of the severe pedestrian/bicycle crashes occurred at signalized intersections. They graphed the crashes by speed, volume, and age of those involved to see if there was an overrepresentation of crashes. What they found was that 80 percent occurred where the posted speed limit was 40 mph or less, and 80 percent occurred on roadways with 17,500 vehicles per day or more. Also, four-legged intersections, undivided roadways, and nearby retail were found to be risk factors. From the age distribution check, they did not find school-age children to be overrepresented in the crashes.

To validate the need for a proactive approach, they determined that along the county road system:

- Approximately 70 percent of severe crashes involving pedestrians or bicycles occur at intersections.
- There were 1587 signalized intersections included in the analysis.
- A total of 122 intersections had a severe pedestrian or bicycle crash in the last 5 years.
- Only 14 of the intersections had multiple severe pedestrian or bicycle crashes—none had more than one severe pedestrian or bicycle crash per year.

Had they been focusing on the intersections where multiple severe crashes occurred, they would have addressed less than 1 percent of the signalized intersections.

Ramsey County was selected to pilot the new process. The project team used corridors instead of intersections since blanketing corridors with strategies seemed a better way to implement safety improvements. The team started with the countermeasures from NCHRP Report 500 and updated them using the FHWA Clearinghouse. The countermeasures for signalized intersections included:

- Advance walk (leading pedestrian interval).
- Curb extensions.
- Medians.
- Countdown signals.
- Sidewalks.

After developing the list of countermeasures, team members created a decision tree to guide them. Figure 2 illustrates this decision tree to help identify low-cost, proactive projects.

Exposure data were not available in Minnesota, so they tried to address exposure by using risk factor surrogates such as pedestrian generators and bus routes.

Since the systematic safety process to address pedestrian safety began in 2011, several million dollars of projects have been identified for pedestrian projects in the Minnesota urban counties, many of which have been submitted for funding. For example, countdown timers and/or advance walk signals, curb extensions, medians, or sidewalks were identified for 16 roadways, which includes 161 locations totaling \$1.7 million in Ramsey County based on the presence of risk factors rather than the presence of pedestrian crashes (27).

In summary, the systematic approach to safety is a proactive way to address crashes in a more aggregate way by identifying high-risk characteristics. Sharp differences are found when evaluating urban and rural roadways separately. Data management and decision tools are critical for the process. Safety projects focusing on rural and local roadways as well as non-motorized modes of travel are more competitive for funding when they have been through the systematic safety approach.

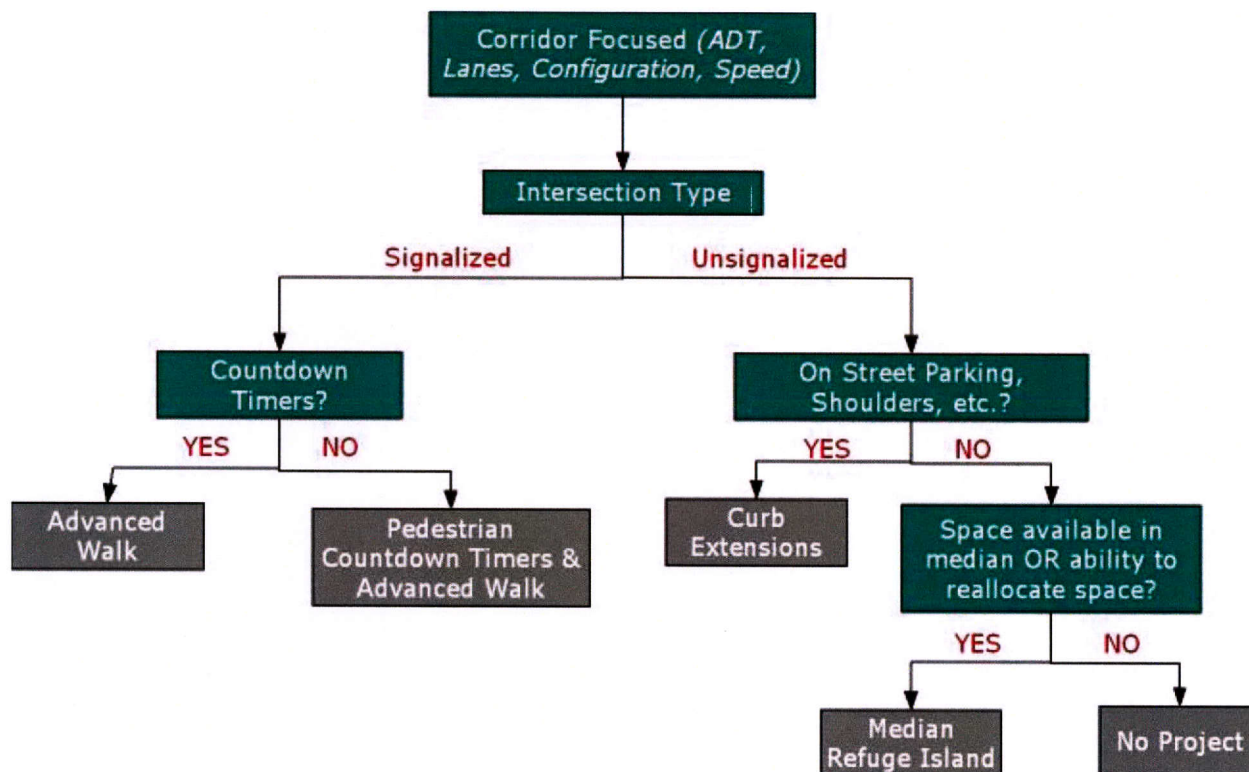


Figure 2. MnDOT Project Development Decision Tree (26).

## SUMMARY

Pedestrian crashes are influenced by demographic/social/policy factors, driver factors, pedestrian factors, roadway/environmental factors, and vehicle factors. The HSM provides CMFs for predicting pedestrian crashes on urban and suburban arterials. A recent FHWA publication also provides estimates of the crash reduction that might be expected if specific countermeasures or a group of countermeasures is implemented with respect to pedestrian crashes. These estimates are a useful guide, but it remains necessary to apply engineering judgment and to consider site-specific environmental, traffic volume, traffic mix, geometric, and operational conditions, which will affect the safety impact of a countermeasure. The traditional approach to addressing safety concerns is location based, and typically these locations have been chosen due to high crash frequency. While this approach works well for motor vehicle crashes, whose frequency is relatively high, for pedestrian crashes, the crashes are more difficult to isolate due to low frequency. In recent literature, a systematic approach to safety that proactively addresses crashes in a more aggregate way by identifying high-risk characteristics is suggested to address pedestrian crashes.





## CHAPTER 4

### LITERATURE REVIEW – TREATMENTS

#### ENGINEERING

This section contains a review of recent literature on engineering treatments and their effectiveness. A list of treatments identified as part of this project is provided in Table 4. There are two ways of determining engineering treatment effectiveness. One is the treatment's ability to change user behavior, and the other is the safety performance of the treatment. The HSM (6) provides safety knowledge and tools in a useful form to facilitate improved decision-making based on safety performance (see previous chapter).

**Table 4. List of Pedestrian Treatments.**

Advance stop or yield line and sign
Barrier – median
Barrier – roadside/sidewalk (railing or fencing)
Beacons
Bus stop location
Crosswalk marking patterns
Curb extensions
Flags (pedestrian crossing)
Illumination
In-roadway warning lights
In-street pedestrian crossing signs
Leading pedestrian interval
Marked crosswalk
Motorist warning signs
Overpasses and underpasses
Pedestrian countdown
Pedestrian hybrid beacon (also known as the HAWK)
Pedestrian scramble
Puffin crossing
Raised crosswalks
Rectangular rapid-flashing beacon
Refuge island
Road diet
Sidewalks
Traffic control signal
Zigzag lines

A variety of engineering (e.g., geometric design, traffic control device) treatments have the potential to improve safety at pedestrian crossings. To understand the effects of these treatments, researchers in the United States, and in other countries, have conducted research studies. The

following sections summarize the documentation of selected treatments and their reported effectiveness.

## **Engineering Treatments – Traffic Control Devices**

### *Advance Yield Line and Sign*

Advance yield lines are pavement markings placed 30 to 50 ft upstream of a crosswalk; YIELD or YIELD HERE TO PEDESTRIAN signs often accompany advance yield lines. Advance yield lines address the issue of multiple-threat crashes on multilane roadways. Multiple-threat crashes are those where one vehicle stops for a pedestrian in the crosswalk, which screens other vehicles from seeing the pedestrian in the crosswalk. Several studies indicate advance yield lines decrease pedestrian-vehicle conflicts and increase the distance between a yielding vehicle and the crosswalk (28, 29, 30, 31). The HSM indicates the crash effects of advance yield lines are presently unknown (6).

Studies by Van Houten and others have demonstrated the effectiveness of advance yield lines and YIELD HERE TO PEDESTRIAN signs (29, 30, 31). This research found a reduction in motor vehicle-pedestrian conflicts and an increase in motorists yielding to pedestrians at uncontrolled approaches with multilane crosswalks. The documented findings are for crosswalks with and without amber flashing beacons. Additionally, Van Houten and Malenfant demonstrated signs with markings are more effective than signs without markings (30). In a 2001 study, Van Houten et al. showed advance yield lines with YIELD HERE TO PEDESTRIAN signs reduce vehicle-pedestrian conflicts by 67 to 87 percent; the study also found an increase in the distance between the yielding vehicles and the pedestrians (31). In another study, researchers were able to replicate these results at 24 sites in Canada (32). These studies indicate that on streets with a posted speed limit of 30 mph (converted from metric), advance yield lines with YIELD HERE TO PEDESTRIAN signs:

- Reduce the percentage of motor vehicle-pedestrian conflicts involving evasive action.
- Increase the percentage of motorists yielding to pedestrians.
- Increase the distance between a yielding vehicle and the crosswalk.

A 2011 paper reported on the installation of advance yield markings with a YIELD HERE TO PEDESTRIAN sign at two midblock locations in Las Vegas, Nevada (33). The report indicates there was an increase in the proportion of drivers yielding to pedestrians at the location with a five-lane cross section with a posted speed limit of 35 mph; the average daily traffic (ADT) at the location was 17,100 veh/day. At the location with a seven-lane cross section, the increase in driver yielding behavior was not statistically significant; the posted speed limit at this site was 30 mph, and the ADT was 43,000 veh/day.

### *Beacons*

Flashing beacons at pedestrian crossings are a common treatment within the United States. The HSM indicates beacons may result in a reduction in crashes; however, their overuse may reduce the effectiveness of this device (6). Communities have installed flashing beacons in a variety of ways:

- At the pedestrian crossing, both overhead and on the side of the roadway.
- In advance of the pedestrian crossing, both overhead and on the side of the roadway.
- In conjunction with or as part of other warning signs.
- Within the pavement (see the section on In-Roadway Warning Lights at Crosswalks).

Flashing amber beacons may have various modes of operation, including:

- Continuous flash mode.
- Pedestrian-activated using manual pushbuttons.
- Passive pedestrian detection using automated sensors (e.g., microwave, video).
- With different flash rates, sequences, or strobe effects.

The various ways of installing beacons have resulted in studies with mixed results. Several studies have shown pedestrian-activated beacons—typically activated using a manual pushbutton or automated sensor—provide a more effective response from motorists than continuously flashing beacons (34, 35). These beacons do not flash constantly; thus, when they are flashing, motorists are more likely to assume a pedestrian intends to cross the street. With pedestrian activation, special signing may be necessary to ensure that pedestrians consistently use the pushbutton activation. Alternatively, automated pedestrian detection is an option and has had some success; this typically requires additional effort in installation and in maintenance.

Overhead flashing beacons appear to have the greatest visibility to motorists, particularly when used at, or in advance of, the pedestrian crossing. Many installations have used both overhead and side-mounted beacons. In general, effectiveness of flashing beacons may be limited on high-speed or high-volume arterial streets. For example, one study showed driver yielding behavior ranges from 30 to 76 percent (with the median values falling in the 50 percent range); however, the evaluations did not contain enough information to attribute yielding values to specific road characteristics (28, 34, 35, 36). The field studies reported in Transit Cooperative Research Program (TCRP) Report 112/NCHRP Report 562 (1) found a similar range of driver yielding values (25 to 73 percent), with the average value for all flashing beacons at 58 percent. Within the TCRP/NCHRP findings, researchers found (on arterial streets) traffic volumes have a statistically significant effect on driver yielding behavior.

Little and Saak evaluated two installations of pedestrian-activated overhead yellow flashing beacons (37). Both sites consisted of a five-lane cross section with an ADT of 7500 or 18,400 veh/day. The motorist compliance at these sites was 64 to 65 percent during the day and 68 to 78 percent at night.

Van Winkle and Neal evaluated the use of pedestrian-actuated beacons and crosswalk flashers in Chattanooga, Tennessee (34). The installation of the crosswalk flashers was a compromise solution for a group of senior citizens who wanted a traffic signal to assist them in crossing a minor arterial street with a speed limit of 40 mph. City staff conducted a before-and-after study in 1987 and then a follow-up data collection in 2000. City staff collected data pertaining to the percentage of drivers yielding or slowing down at the pedestrian crosswalk. The 1987 data showed driver yielding improved from 11 to 52 percent in the eastbound direction and from 6 to 32 percent in the westbound direction. The 2000 data indicated a sustained long-term improvement; the yielding percentages were 55 percent in the eastbound direction and 45 percent

in the westbound direction. The authors attribute the success of the flashers to pedestrian actuation. The City of Chattanooga has installed similar devices at three other locations and observed similar yielding behavior; however, the city has not conducted formal studies at those locations.

In 1990, Sparks and Cynecki reported on the use of flashing beacons for warning of pedestrian crosswalks in Phoenix, Arizona (38). The city evaluated the application of advance warning flashing beacons at four pedestrian crossing locations. The authors used a multi-method approach in their investigation; they conducted before-and-after analyses of speed and crash data and had control sites for the speed analysis. The authors found that the advance warning flashing beacons did not decrease speeds or crashes; and, in some cases, the traffic speeds or crashes increased after installation of the flashing beacons. These findings led the authors to conclude, "Flashers offer no benefit for intermittent pedestrian crossings in an urban environment. In addition, the longer the flashers operate the more it becomes part of the scenery and loses any effectiveness." The authors concede actuated warning flashers may be beneficial in high-speed rural environments with unusual geometrics, high pedestrian crossings, and unfamiliar drivers; however, they were unable to test this hypothesis in their study.

### *Crosswalk Marking Patterns*

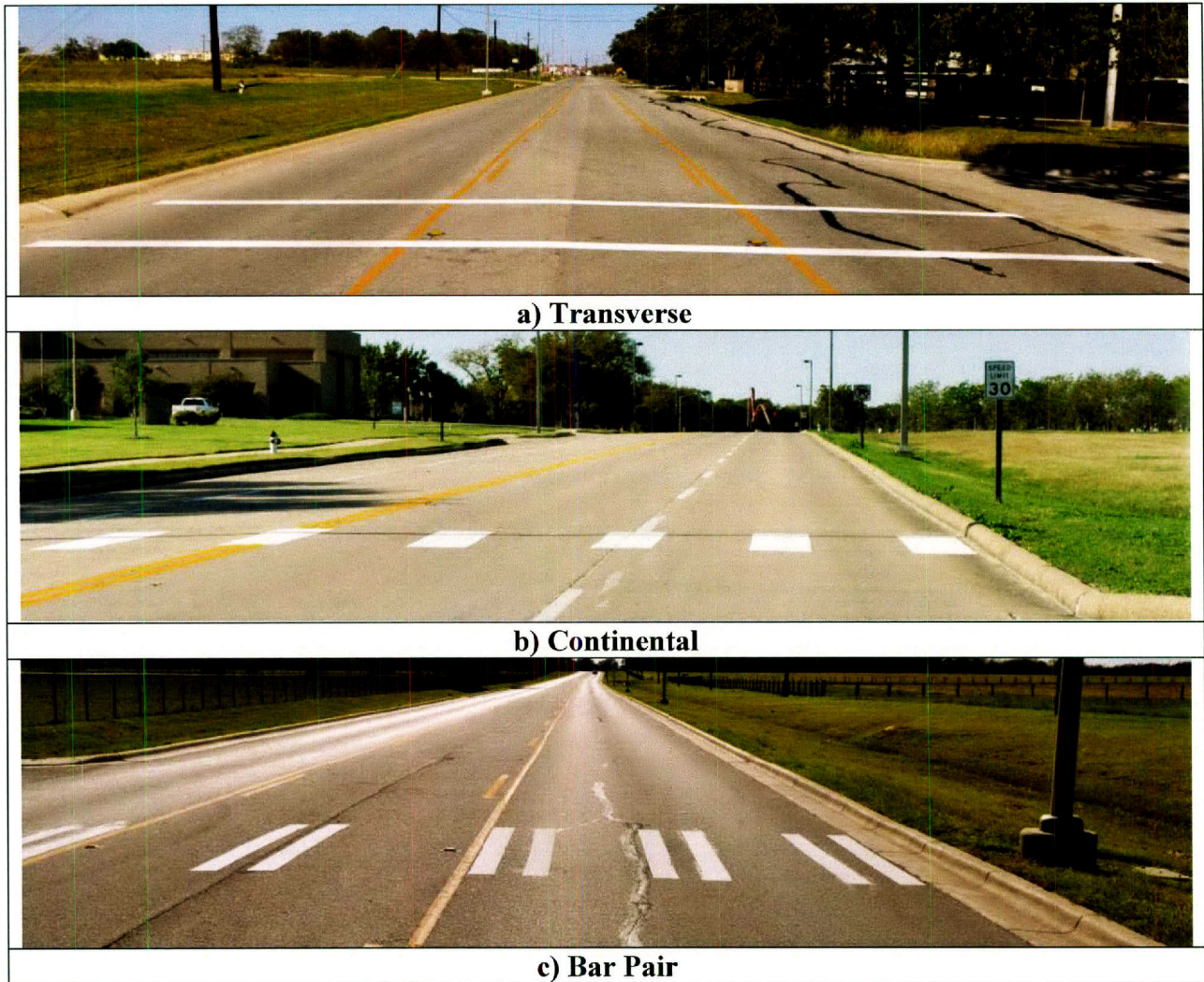
In a 2009-2010 FHWA study, researchers investigated the relative daytime and nighttime visibility of three crosswalk-marking patterns: bar pairs, continental, and transverse lines (39). In this study, researchers used instrumented vehicles to record the distance at which 78 participants verbally indicated recognition of crosswalks at various locations around Texas A&M University's campus in College Station, Texas. The tests used existing markings (six intersection and two midblock locations) and new markings specifically installed for the study (nine midblock locations). For the study sites, the findings indicate that the marking type was statistically significant; the types of markings used in this study are shown in Figure 3.

There was no statistical difference between bar pair and continental markings. The detection distances for bar pair and continental markings were longer than the detection distance to the transverse markings, both at night and during the day. For existing midblock locations, the detection distance for continental markings was approximately twice the detection distance for transverse markings (prior to this study there were no bar pair markings). At 30 mph, the additional distance translates to an additional 8 seconds of crosswalk awareness.

Additionally, researchers had participants rate the appearance of markings using a letter-grade scale (from A to F). Overall, participants rated the bar pair and continental markings similarly; they both had better ratings than the transverse markings. These results mirrored findings in the detection distance evaluation. The research team is working with the National Committee on Uniform Traffic Control Devices to incorporate the findings into the MUTCD.

A 2010 study in San Francisco, California, looked at findings from an empirical Bayes (EB) evaluation of high-visibility school crosswalks (24). The analysis used data from 54 intersections with high-visibility crosswalks (treatment intersections) and 54 intersections without high-visibility crosswalks (control intersections); researchers selected each control intersection

for its geographical proximity to a treatment intersection. The study found a 37 percent reduction in crashes at the sites with high-visibility crosswalks; these findings were statistically significant.



**Figure 3. Examples of Marking Types Used in Visibility Study (39).**

### *Flags*

Several cities (e.g., Salt Lake City, Utah; Kirkland, Washington; Berkeley, California) have used fluorescent orange flags, which crossing pedestrians carry with them. Salt Lake City uses flags near the downtown area where the speed limit is 30 mph or less; however, several of these streets are multi-lane, high-volume arterials. Field studies documented in TCRP Report 112/NCHRP Report 562 found pedestrian crossing flags in Salt Lake City and Kirkland to be moderately effective (1). The study sites with crossing flags had driver yielding rates ranging from 46 to 79 percent, with an average of 65 percent compliance. Several of the study sites had four or more lanes with speed limits of 30 mph or 35 mph.

### *In-Roadway Warning Lights at Crosswalks*

As a specific design case of flashing beacons, in-roadway warning light installations have proliferated since the 1990s. Their use originated in California and Washington State; however, they have spread to numerous other cities in the United States. In-roadway warning lights are mounted in the pavement near the crosswalk markings such that they typically protrude above the pavement less than 0.5 inch. As with flashing beacons, the experience with in-roadway warning lights has been mostly positive but with a few negative results.

Many early, and some current, equipment designs for the in-roadway warning lights have been problematic. Some of the problems encountered are as follows:

- Snowplows damage the flashing light enclosures.
- Light lenses become dirty from road grit and require regular cleaning.
- Automated pedestrian detection does not operate effectively.

Through experience, many of the early problems have been resolved; however, some cities are cautious in specifying more in-roadway warning lights without long-term experience. Some cities have noted their preference for overhead flashing beacons instead of in-roadway lights because of poor visibility issues when traffic is queued in front of the in-roadway lights (35, 40). As another concern, flashing lights are difficult for drivers to see in bright sunlight.

Numerous studies have evaluated in-roadway warning lights with varying results. It appears that the effectiveness of this treatment varies widely depending upon the characteristics of the site and existing motorist and pedestrian behavior.

For most of the installations, in-roadway warning lights have increased driver yielding 50 to 90 percent (36, 41, 42, 43, 44, 45). Additionally, in-roadway warning lights typically increase the distance that motorists first brake for a pedestrian crossing; this indicates motorists are recognizing the pedestrian crossing, and the need to yield, sooner (41, 42, 43, 44). These results have been even more dramatic at night, the time when in-roadway warning lights are highly visible. For a few installations, driver yielding decreased or did not increase above 35 percent (36, 37, 46).

Within the [walkinginfo.org](http://walkinginfo.org) website, Thomas provided a review of an in-roadway warning light system (IRWL) (47). Within his review, Thomas identifies nine studies evaluating potential safety effects with behavioral measures of effectiveness. Thomas notes the following results (47):

- Most studies reported short-term improvements in driver yielding to pedestrian behavior, while a number of locations, approaches, and study conditions reported little or no improvement (45, 46, 48, 49).
- In two studies, nighttime trends were greater than daytime trends; however, effects under other sub-optimal visibility conditions (e.g., rain or fog) have not been clearly studied (45, 50).
- Two studies had conflicting results pertaining to IRWL improving yielding to pedestrians when the pedestrian is in the middle of crossing (36, 48). This measure of effectiveness (MOE) may have greater bearing on safety than yielding for pedestrians waiting or just

beginning to cross. Future research efforts should study the effect of IRWL when pedestrians are in the middle of their crossing, particularly for multi-lane roads. In the meantime, agencies should exercise caution, and use additional treatments, if they are considering IRWLs at uncontrolled crosswalks on multi-lane roadways.

- IRWL effects on motorist speeds were also mixed:
  - Improvement or slight improvement in speeds (45, 51, 52).
  - No improvement (45, 49).
  - Mixed results for some locations and study conditions (45, 48).
- IRWL effects on motorists and pedestrian crosswalks varied as well, as did the definition of conflict. Authors reported:
  - In one study, a non-significant increase in conflicts (51).
  - In Israel, reduced conflicts at all four study locations (48).
  - In one study, no improvements related to installation of the IRWL; however, a reduction in conflicts following installation of high-visibility crosswalks and sidewalk improvements (53).
  - In an after-period-only evaluation, fewer conflicts at locations with IRWL than at locations without IRWL (49).
- Data for longer-term studies are lacking. When data were available, researchers found improvement in yielding behaviors were greater closer to installation, with a worsening trend as time since installation became larger (45, 48, 53). Thus, these data suggest a potential degradation of initial improvements, and agencies should monitor treatments at repeated intervals for a year, or more, after installation of IRWL. Certainly, agencies and researchers should consider any available crash data and crash characteristics.
- Most studies looked at one treatment site, and zero studies included comparison or control sites in their evaluation. In several studies, researchers reported the influence of confounding treatments and other conditions. In most studies, researchers looked at the short-term effects of treatments; most studies looked at the effects less than a month after treatment implementation, and few used data collected more than a month, let alone several months, after the treatment.

The following paragraphs provide a sample of additional details pertaining to the evaluation of in-roadway warning lights.

In 1998, Whitlock and Weinberger Transportation, Inc. summarized results of an in-roadway warning lights evaluation at numerous locations in California (41). In these installations, the in-roadway warning lights were supplemented with a pedestrian crosswalk sign with warning amber light-emitting diode (LED) lights, as well as a pedestrian-activated pushbutton with flashing LEDs and CROSS WITH CAUTION signs. Researchers reported results using two MOEs: (a) percentage of motorists yielding to pedestrians, and (b) advance vehicle braking distance. These MOEs are shown in Table 5 for daytime and nighttime conditions. These data indicate an increase in the percentage of motorists yielding to pedestrians at all six study sites. Typically, improvements in driver yielding behavior were greater for nighttime conditions. The advance braking distance MOE data showed similar results with drivers braking sooner and greater improvements at night.

In the fall of 1997, the City of Kirkland, Washington, installed in-roadway warning lights at two midblock locations (43). Whitlock and Weinberger Transportation, Inc. evaluated the crossing treatments at these locations and reported the results using the same two MOEs as the California study (see Table 6). The evaluation team found improvements to both MOEs after installation, with more dramatic improvements evident during nighttime tests. Before installation, driver yielding ranged from 16 to 65 percent. After installation of the in-roadway warning lights, driver yielding ranged from 85 to 100 percent. The study found that “the concept of amber flashing lights embedded in the pavement at uncontrolled crosswalks clearly has a positive effect in enhancing a driver’s awareness of crosswalks and modifying driving habits to be more favorable to pedestrians.”

**Table 5. Evaluation of In-Roadway Warning Lights in California (41).**

Location	Percentage of Motorists Yielding to Pedestrians				Advance Vehicle Braking Distance (ft)			
	Daytime		Nighttime		Daytime		Nighttime	
	Before	After	Before	After	Before	After	Before	After
Summerfield Rd., Santa Rosa	25	64	1	87	152	220	187	268
Main St., Fort Bragg	47	85	11	95	106	142	90	216
Mt. Diablo Blvd., Lafayette	6	21	1	53	130	127	93	174
Pleasant Hill Rd., Lafayette	8	32	2	39	173	210	201	318
Petaluma Blvd. S., Petaluma	68	87	56	83	99	119	97	123
JFK University, Orinda	18	23	16	31	115	104	122	146
Main St., Willits	26	61	6	66	170	193	141	228
<b>Unweighted Average</b>	<b>28</b>	<b>53</b>	<b>13</b>	<b>65</b>	<b>135</b>	<b>159</b>	<b>133</b>	<b>210</b>

In Denville, New Jersey, at a single location with two crosswalks, Boyce and Van Derlofske compared the effectiveness of in-roadway warning lights to basic crosswalk markings (53). The authors found the in-roadway warning lights resulted in a decreased speed at which vehicles approached the crosswalk; however, the speed reduction diminished over time. Additionally, with the in-roadway warning lights installed, vehicle-pedestrian conflicts increased over time. The authors also reported several problems with this specific implementation of in-roadway warning lights.

**Table 6. Evaluation of In-Roadway Warning Lights in Kirkland, Washington (43).**

Location	Percentage of Motorists Yielding to Pedestrians				Advance Vehicle Braking Distance (ft)			
	Daytime		Nighttime		Daytime		Nighttime	
	Before	After	Before	After	Before	After	Before	After
Central Way EB	62	92	16	100	200	278	115	238
Central Way WB	59	94	27	98	192	244	175	270
NE 124 <sup>th</sup> Street EB	46	85	65	93	209	214	204	244
NE 124 <sup>th</sup> Street WB	55	92	48	97	271	312	266	304
<b>Unweighted Average</b>	<b>56</b>	<b>91</b>	<b>39</b>	<b>97</b>	<b>218</b>	<b>262</b>	<b>190</b>	<b>264</b>

In 2000, Katz, Okitsu, and Associates prepared a study of in-roadway warning lights for Fountain Valley, California (44). Their study analyzed the reported safety record of approximately 30 treatment locations in place for more than 1 year and compared it with the



expected safety record for traditional crosswalk treatments. The results indicate an 80 percent reduction in expected crashes; however, authors were not sure if the reduction was a novelty effect or will continue over time. Additionally, the study found that marked crosswalks with in-roadway flashers had a lower crash rate than comparable marked crosswalks.

In 2000, Huang et al. documented the evaluation of in-roadway warning lights at a single location in Orlando, Florida (46). The evaluation, which was conducted to determine the effects of the in-roadway warning lights on pedestrian and motorist behavior, collected both before-and-after and treatment-and-control data. The authors reported these results:

- Average vehicle speeds decreased by 1.9 mph when a pedestrian was present and 0.8 mph when no pedestrians were present, but the decreases were not significant.
- Vehicle yielding improved from 13 percent before to 34 percent (when flashers were activated) and 47 percent (when flashers were not activated) after installation. The authors could not explain increased yielding with inactive flashers.
- Approximately 28 percent of the pedestrians crossed in the flashing crosswalk when police officers were not present. Depending on the most convenient path between their origins and destinations, the remaining 72 percent of pedestrians crossed elsewhere.
- Of the pedestrians who crossed in the flashing crosswalk, 40 percent did not experience any conflicts. This compared to 22 percent of those who crossed within 30 ft (9.2 m) and only 13 percent of those who crossed elsewhere. The researchers concluded that motorists were more likely to stop or slow for pedestrians who crossed in or near the flashing crosswalk than those who crossed elsewhere.

In a subsequent study, Huang evaluated in-roadway warning lights at two uncontrolled pedestrian crossings in Florida—one in Gainesville and one in Lakeland (36). The evaluation used traditional before-and-after data collection and used the following MOEs: (a) motorists yielding to pedestrians, (b) pedestrians who had the benefit of motorists yielding to them, (c) pedestrians who crossed at a normal walking speed, and (d) pedestrians who crossed in the crosswalk. The results were different between the two study sites. In Gainesville, driver yielding actually decreased from 81 to 75 percent. Although the decrease was significant, authors concluded it was negligible because of site characteristics. At the Lakeland site, driver yielding improved from 18 to 30 percent, but because of low sample size, this result was not statistically significant. Results for the other MOEs were uninformative because researchers did not observe major changes.

In 2001, Prevedouros reported on the evaluation of in-roadway warning lights installed on a six-lane arterial street in Honolulu, Hawaii (45). In a traditional before-and-after study, Prevedouros collected traffic volumes, vehicle spot speeds, pedestrian crossing observations, pedestrian perception, and motorist perception. The author reported:

- A 16- to 27-percent reduction in vehicle speeds when the flashing lights were active.
- A decrease in average pedestrian wait time from 26 to 13 seconds and a decrease in average crossing time from 34 to 27 seconds. The crossing time decrease came from pedestrians spending less time in the refuge island before crossing the second direction.
- A 22- to 12-percent reduction in the proportion of pedestrians running during their crossing after installation of the flashing lights. Additionally, the proportion of pedestrians crossing outside the marked crosswalk decreased from 16 to 8 percent.

### *In-Street Pedestrian Crossing Signs*

In-street pedestrian crossing signs (2003 MUTCD R1-6 and R1-6a signs) are intended for use at uncontrolled (unsignalized) crosswalks. The signs are installed in the centerline or in the median and have a portable or fixed base. Because the signs are located between the lanes, they can have a traffic-calming effect from the narrowing of the lanes.

A 2009 report (54) documented the implementation of three area-wide countermeasure programs in three cities: Las Vegas, Nevada; Miami-Dade, Florida; and San Francisco, California. The three cities installed the signs in different locations and used a different number of signs. The signs proved to be effective in increasing driver yielding (see Table 7); driver yielding increased between 13 and 46 percent depending on the location. There were no significant changes in the percentage of pedestrian-vehicle conflicts at the Miami sites or at two of the three sites in San Francisco. One location in San Francisco (Mission & Admiral) experienced a significant decrease in pedestrian-vehicle conflicts. The treatment reduced conflicts from 17.1 percent in the baseline to 2.1 percent after installation of the signs.

**Table 7. Driver Yielding at In-Street Installations (54).**

Site	Number		% of Drivers Yielding to Pedestrians			
	Before	After	Before	After	% Change	P-value
Miami: Collins & 6 <sup>th</sup>	400	440	32	78	46	0.01
Miami: Collins & 9 <sup>th</sup>	400	240	21	65	44	0.01
Miami: Collins & 13 <sup>th</sup>	1200	200	34	69	35	0.01
San Francisco: 16 <sup>th</sup> & Capp (marked crosswalk)	519	447	61	74	13	<0.01
San Francisco: 16 <sup>th</sup> & Capp (unmarked crosswalk)	96	109	40	60	20	<0.01
San Francisco: Mission & France	164	91	43	78	35	<0.01
San Francisco: Mission & Admiral	41	47	22	57	35	<0.01
Las Vegas: Bonanza between D and F	89	106	74	47	-27*	>0.05
Las Vegas: Twain between Cambridge and Swenson	141	79	7	35	18	<0.01

\*Counterintuitive result; results are not significant due to 1-tailed test.

In 2007, Ellis, Jr. et al. compared the effect of in-street pedestrian crossing signs on driver yielding behavior. In the study, signs were placed at three positions relative to the crosswalk—at 0 ft, 20 ft, and 40 ft in advance of the crosswalk—and three sites were evaluated (55). Data showed an increase in driver yielding behavior at all three sites; additionally, installation at the crosswalk line was as effective as or more effective than installation 20 or 40 ft in advance of the crosswalk. The study also looked at simultaneous installation of all three distances; however, this was no more effective than installation at the crosswalk. These data suggest the in-roadway sign is effective because the placement is salient to drivers. Because drivers frequently struck the sign

at one of the sites, the authors recommend placing signs on median islands whenever possible (to extend their useful lives).

In a TCRP/NCHRP project, in-street pedestrian crossing signs were examined (1). The field studies indicated that in-street signs have relatively high driver yielding (ranged from 82 to 91 percent, for an average of 87 percent); all three sites were on two-lane streets with posted speed limits of 25 or 30 mph.

In 2011, a paper reported on the installation of in-street pedestrian crossing signs at three midblock locations in Las Vegas, Nevada (33). The results either (a) showed a decrease in driver yielding, or (b) were not statistically significant. The signs were installed on roads with 35-mph speed limits, five- or seven-lane cross sections, and ADTs between 17,100 and 21,400 veh/day. The wide crossing may have contributed to the decrease in driver yielding.

As a low-cost pedestrian safety improvement, the Pennsylvania Department of Transportation has a program to provide yield-to-pedestrian channelizing devices (YTPCDs) to municipalities. To remind motorists of the need to yield to pedestrians, YTPCDs are placed on the centerline of a roadway in advance of marked crosswalks. A research report by Strong and Kumar, and paper by Strong and Bachman, summarized an evaluation of YTPCDs (56, 57). In 2006, researchers collected before-and-after data in four types of communities (urban, suburban, small city, and college town). Sites included crosswalks at unsignalized intersections (eight sites) and midblock locations (four sites). The speed limits at the sites were either 25 or 35 mph. Researchers collected data to determine if motorists were more likely to yield to pedestrians. The analysis showed a statistically significant increase in driver yielding. Table 8 provides the study's results along with findings from other studies (56, 57, 58, 59, 60, 61).

### *Leading Pedestrian Interval*

A leading pedestrian interval is a 3- to 7-second phase for pedestrians to begin their crossing, which occurs during an all-red phase for motor vehicles. In 2010, Fayish and Gross published a before-and-after study with comparison groups, which found a 58.7 percent reduction in pedestrian-vehicle crashes associated with a leading pedestrian interval (62). This study compared 10 sites with countdown signals to 14 stop-controlled intersections; 3 to 4 years of crash data were available in the before period and 3 years were available for the after period. Previous investigations found a 5 percent reduction in crashes as shown in the FHWA brief (8).

### *Marked Crosswalks*

To date, Zegeer et al. have performed the most authoritative study on the effectiveness of crosswalk pavement markings without other treatments at locations (20, 63). Within the study, researchers evaluated 5 years of pedestrian collisions in 30 U.S. cities at 1000 marked crosswalks and 1000 matched, unmarked comparison sites. For two-lane roads or low-volume four-lane roads, marked crosswalks provide no meaningful differences in crash risk compared to unmarked crosswalks. Additionally, as traffic volumes, speeds, and street widths increase, the crosswalk markings, without other treatments, are associated with a greater crash frequency when

compared to no crosswalk markings. To provide a safer street crossing for pedestrians, the study recommends providing treatments in addition to crosswalk markings.

**Table 8. Evaluation Results on In-Street Pedestrian Crossing Signs.**

Location	Measure of Effectiveness	Result	Reference
Miami, Florida; San Francisco, California; Las Vegas, Nevada	Driver Yielding	Before = 7 to 74% After = 35 to 78% Increase = 13 and 46%	Pécheux, K., J. Bauer, P. McLeod. <i>Pedestrian Safety and ITS-Based Countermeasures Program for Reducing Pedestrian Fatalities, Injury Conflicts, and Other Surrogate Measures Draft Zone/Area-Wide Evaluation Technical Memorandum</i> . Contract # DTFH61-96-C-00098; Task 9842. 2009. (54)
TCRP/NCHRP	Driver Yielding	With signs = 82 to 91%	Fitzpatrick, K., S. Turner, M. Brewer, P. Carlson, B. Ullman, N. Trout, E.S. Park, J. Whitacre, N. Lalani, D. Lord. <i>Improving Pedestrian Safety at Unsignalized Crossings</i> . TCRP Report 112/NCHRP Report 562. 2006. (1)
Pennsylvania (Philadelphia Haverford Township, Pottstown, and West Chester)	Motorists Yielding – Intersection Locations	Before = 27% After = 59% Increase = 30 to 34%	Strong, C., and M. Kumar. “Safety Evaluation of Yield-to-Pedestrian Channelizing Devices.” Western Transportation Institute. Montana State University. 2006. (56)
	Motorists Yielding – Midblock Locations	Before = 10% After = 30% Increase = 17 to 24%	Strong, C., and D. Bachman. “Safety Evaluation of Yield-to-Pedestrian Channelizing Devices.” In TRB 87th Annual Meeting Compendium of papers DVD. 2008. (57)
<b>Previous studies as reported by Strong and Kumar (56) or Strong and Bachmann (57)</b>			
New York State and Portland, Oregon	Pedestrians for Whom Motorists Yielded	+12%	Huang, H., C. Zegeer, and R. Nassi (2000). “Effects of Innovative Pedestrian Signs at Unsignalized Locations: Three Treatments.” In Transportation Research Record 1705, Transportation Research Board, National Research Council, Washington, D.C., pp. 43–52. (58)
	Pedestrians that Ran, Aborted, or Hesitated	–2%	
	Pedestrians Crossing in Crosswalk	No change	
Cedar Rapids, Iowa	Motorists Yielding	+3 to 15%	Kannel, E.J., R.R. Souleyrette, and R. Tenges (2003). <i>In-Street Yield to Pedestrian Sign Application in Cedar Rapids, Iowa</i> , Center for Transportation Research and Education, Iowa State University, Ames, IA. (59)
Minnesota	Speed Compliance	+20%	Kamyab, A., S. Andrie, and D. Kroeger (2002). <i>Methods to Reduce Traffic Speed in High Pedestrian Areas</i> , Report 2002-18, Prepared for the Minnesota Department of Transportation, St. Paul, MN. (60)
Madison, Wisconsin	Motorists Yielding	+5 to 15%	City of Madison Traffic Engineering Division (1999). “Year 2 Field Evaluation of Experimental ‘In-Street’ Yield to Pedestrian Signs,” City of Madison Department of Transportation, Madison, WI. (61)

In 2002, Koepsell et al. looked at the effect of crosswalk markings on crashes involving older pedestrians (64). For six cities in Washington State and California from 1995 to 1999, the study gathered crash data and other site characteristics (e.g., traffic and pedestrian volumes, traffic speed, signalization characteristics). The study used a case-control design and compared 282 case sites to 564 control sites. After adjusting for the various traffic and pedestrian characteristics, researchers found the risk of a pedestrian-vehicle crash was 3.6 times greater at uncontrolled intersections with a marked crosswalk. At intersections with a stop sign or traffic signal, there was “virtually no association between presence of markings and pedestrian-motor vehicle collision risk.”

Knoblauch, Nitzburg, and Seifert reported on a study of the effects of pedestrian crosswalk markings on pedestrian and driver behavior (65). The study included 11 unsignalized intersections in four cities: Sacramento, California; Richmond, Virginia; Buffalo, New York; and Stillwater, Minnesota. The researchers considered the following behaviors in their evaluation:

- Pedestrian compliance to crossing location.
- Vehicle speeds.
- Vehicle yielding compliance.
- Pedestrian behavior in relation to caution.

The authors present the following conclusions:

- Drivers appeared to drive slower when approaching a marked crosswalk. The speed reductions are modest but evident. This finding implies most motorists are aware of the pedestrian crossing.
- Researchers did not observe a change in driver yielding behavior after the installation of marked crosswalks. This implies motorists may slow down in case a pedestrian forces them to stop by stepping into the roadway.
- There were no changes in aggressive pedestrian behavior after installations of marked crosswalks, indicating pedestrians may not feel protected by marked crosswalks.
- Overall, after installing markings, crosswalk usage increased. The authors found single pedestrians are more likely to use marked crosswalks than a group of pedestrians traveling together.

Gibby et al. analyzed pedestrian-vehicle crash data at 380 State highway intersections in California (66). The study found crash rates at marked crosswalks was 3.2 to 3.7 percent higher than crash rates at unmarked crosswalks (after accounting for pedestrian exposure). This result corresponds to earlier work in San Diego by Herms (67, 68); it also correlates to Zegeer’s study (20). This implies marked crosswalks, without other treatments, are not sufficient on multilane streets with high traffic volumes and speeds.

In the late 1960s, Herms examined 5 years of crash experience at 400 unsignalized intersections in San Diego, California (67, 68). The study found nearly six times as many crashes occurred in marked crosswalks as in unmarked crosswalks. After accounting for crosswalk usage, the crash ratio was reduced to about three times as many crashes in marked crosswalks. Many have criticized this study as leading to the removal of pedestrian accommodation on city streets. Now,

professionals believe in supplementing crosswalk markings with other types of safety treatments instead of removing them.

*Motorist Warning Signs*

Within the Miami, Florida, metropolitan area, officials installed pedestrian crossing signs at several locations (55). Officials tested the signs at a midblock location on Collins Avenue. Collins Avenue has a two-lane cross section with on-street parking, an ADT of 29,500 veh/day, and a speed limit of 30 mph. Following installation of pedestrian crossing signs, there were no significant changes in average vehicle speed or the percentage of drivers braking for pedestrians. No conflicts were observed in the before or after conditions. The operating speed at the site in the before condition was 10 mph below the posted speed limit of 30 mph, which the authors suggested as a reason for not observing a change in speed.

Huang et al. evaluated three innovative pedestrian signing treatments in Seattle, Washington; New York State; Portland, Oregon; and Tucson, Arizona (58). The three treatments evaluated were an overhead crosswalk sign, a pedestrian safety cone typically placed in the roadway, and an overhead flashing regulatory sign prompting motorists to stop for pedestrians in the crosswalk. The evaluation used traditional before-and-after data collection for three MOEs: (a) percentage of pedestrians for whom motorists yielded; (b) percent of pedestrians who ran, hesitated, or aborted; and (c) percent of pedestrians crossing in the crosswalk. The results of the study are shown in Table 9. All treatments showed improvements in driver yielding, except the overhead flashing sign in Tucson. The authors indicate the effectiveness of the flashing regulatory sign might be limited due to their installation on four-lane and six-lane arterial streets with speed limits of 40 mph (the other study locations were primarily two-lane streets with speed limits of 25 or 30 mph).

**Table 9. Effectiveness of Pedestrian Treatments at Unsignalized Locations (58).**

Study Location	Percent of Pedestrians for whom Motorists Yielded	Percent of Pedestrians who Ran, Hesitated, or Aborted	Percent of Pedestrians Crossing in the Crosswalk
Overhead CROSSWALK sign (1 site in Seattle)	Before – 46 After – 52	Before – 58 After – 43	Before – 100 After – 100
In-roadway pedestrian safety cone (6 sites in New York, 1 site in Portland)	Before – 70 After – 81	Before – 35 After – 33	Before – 79 After – 82
Overhead flashing crosswalk regulatory sign (3 sites in Tucson)	Before – 63 After – 52	Before – 17 After – 10	Before – 94 After – 94

In TCRP Report 112/NCHRP Report 562, authors examined high-visibility signs and markings (1). The results demonstrate the effect of higher posted speed limits. One site had high-visibility signs and markings, a posted speed limit of 25 mph, and a driver yielding value of 61 percent; however, the other two study sites had a posted speed limit of 35 mph and driver yielding values of 10 and 24 percent (an average of 17 percent).

### *Pedestrian Countdown Signal*

Pedestrian countdown signals indicate the number of seconds a pedestrian has before the pedestrian crossing phase ends. In 2000, Huang and Zegeer conducted a treatment and control study using two treatment intersections and three control intersections in Lake Buena Vista, Florida (69). Huang and Zegeer looked at pedestrian compliance with the flashing “Don’t Walk” signal, pedestrians running out of time, and pedestrians running at the beginning of the flashing “Don’t Walk” phase. They found pedestrians were less likely to run at the beginning of a flashing “Don’t Walk” signal at the treatment sites and there was no significant change in the proportion of pedestrians finishing their crossing prior to the solid “Don’t Walk” signal. However, they did find pedestrians were more likely to begin a crossing after the flashing “Don’t Walk” signal began at the pedestrian countdown signal sites.

### *Pedestrian Hybrid Beacon (Also Known as HAWK)*

The pedestrian hybrid beacon is located both on the roadside and on mast arms over the major approaches to an intersection. The head of the pedestrian hybrid beacon consists of two red lenses above a single yellow lens. It is normally “dark,” but when activated by a pedestrian, it first displays a few seconds of flashing yellow followed by a steady yellow change interval, and then displays a steady red indication to drivers, which creates a gap for pedestrians to use to cross the major roadway. During the flashing pedestrian clearance interval, the pedestrian hybrid beacon changes to a wig-wag flashing red to allow drivers to proceed after stopping if the pedestrian has cleared the roadway, thereby reducing vehicle delays.

In a recent study, researchers conducted a before-and-after evaluation of the safety performance of the pedestrian hybrid beacon (16). Using an empirical Bayes method, their evaluations compared the crash prediction for the before period without the treatment to the observed crash frequency after installation of the treatment. To develop the data sets used in the evaluation, researchers counted the crashes occurring 3 years before and 3 years after the installation of the pedestrian hybrid beacon.

Researchers created two crash data sets. The first data set included crashes coded as occurring at the intersecting streets (identified by using street names). The second data set was a subset of the first data set and only included those crashes that had “yes” for the intersection-related code in the police report.

The crash categories examined in the study included total, severe, and pedestrian crashes. From the evaluation considering data for 21 treatment sites and 102 unsignalized intersections (reference group), the researchers found the following changes in crashes following installation of the pedestrian hybrid beacons:

- A 29 percent reduction in total crashes (statistically significant).
- A 15 percent reduction in severe crashes (not statistically significant).
- A 69 percent reduction in pedestrian crashes (statistically significant).

FHWA added the pedestrian hybrid beacon to the MUTCD in the 2009 edition (see Chapter 4F) (2). However, the pedestrian hybrid beacons included in the safety study differ from the material

in the 2009 MUTCD in the following ways (the installations included in the safety study preceded the MUTCD guidance):

- Section 4F.02 of the MUTCD states, “When an engineering study finds that installation of a pedestrian hybrid beacon is justified, then ... the pedestrian hybrid beacon should be installed at least 100 feet [31 meters] from side streets or driveways that are controlled by STOP or YIELD signs.” All 21 pedestrian hybrid beacons included in this study are located either at a minor intersection (where the minor street is controlled by a STOP sign) or at a major driveway (where the driveway is controlled by a STOP sign).
- The 2009 MUTCD depicts an R10-23 sign with the symbolic red circle and a white background for the word “crosswalk” on the sign. The signs typically used at the pedestrian hybrid beacon locations do not have the symbolic red circle, and the crosswalk background is yellow.

The MUTCD includes guidelines for the installation of the pedestrian hybrid beacons for low-speed roadways where speeds are 35 mph or less, and high-speed roadways where speeds are more than 35 mph.

### *Puffin*

In England, a report documented safety at puffin (pedestrian user-friendly intelligent) crossings (70). Puffins have (71, 70):

- Nearside pedestrian signals that encourage pedestrians to view oncoming traffic.
- No flashing pedestrian green period as at pelican crossings or pedestrian signal blackout period at junctions (simplifies pedestrian signal phasing to “green man” for walk and “red man” for don’t walk and eliminates a flashing “don’t walk” for “don’t start” phase).
- On-crossing pedestrian detectors that provide an extension to the pedestrian clearance period while pedestrians are still within the crossing.
- No flashing amber traffic period as at pelican crossings.
- An indicator light that confirms when the pedestrian signal has been activated.
- Pedestrian curbside detectors to cancel the pedestrian demand if there are no pedestrians in the wait areas.

Puffins were developed in England to replace pelican crossings at midblock sites and farside pedestrian signals at junctions. As reported by Maxwell et al., compared to existing pedestrian signal facilities, puffin facilities can reduce both driver and pedestrian delay at junctions and improve pedestrian comfort, particularly for older pedestrians and those with impaired mobility (70). The aim of the Maxwell et al. study was to quantify the safety benefit. Crash data were analyzed from 50 sites (40 midblock crossings and 10 junctions) that were converted to puffin facilities from pelican crossings and farside pedestrian signals at junctions. The sites had no other significant changes in layout or operation and were in general conformance with current puffin guidance. Statistical analysis was undertaken by using a generalized linear model, which included time trends and seasonal factors. Midblock puffin crossings were shown to be safer than pelican crossings as follows:

- 17 percent lower for injury crashes at the midblock sites (statistically significant at the 5 percent level).



- 19 percent lower for injury crashes over all the sites (statistically significant at the 5 percent level).
- 24 percent lower for all pedestrian crashes (statistically significant at the 10 percent level).
- 16 percent lower for all vehicle crashes (statistically significant at the 10 percent level).

### *Rectangular Rapid-Flashing Beacon*

The rectangular rapid-flashing beacon flashes in an eye-catching sequence to draw drivers' attention to the sign and the need to yield to a waiting pedestrian. It is located on the side of the road below pedestrian crosswalk signs, and can be activated by a pedestrian either actively (pushing a button) or passively (detected by sensors). Each side of an LED flasher illuminates in a wig-wag sequence (left and then right).

A recent study evaluated RRFBs at 22 sites in St. Petersburg, Florida; Washington, D.C.; and Mundelein, Illinois (72). The RRFBs produced an increase in yielding behavior at all locations (see Table 10). During the baseline period before the introduction of the RRFB, yielding for individual sites ranged between 0 and 26 percent. The average yielding for all sites was 4 percent before installation of the RRFBs. Within 7 to 30 days, the average yielding behavior changed to 78 percent from the baseline condition, a statistically significant increase. Similar yielding values occurred during the remaining observation days.

Data collected over a 2-year period, at 18 of the sites, confirmed that the RRFBs continue to succeed at encouraging drivers to yield to pedestrians, even over the longer term. By the end of the 2-year follow-up, the researchers determined that the introduction of the RRFB was associated with yielding that ranged between 72 and 96 percent. Therefore, researchers concluded the evidence for change was overwhelming and persisted for the duration of the study.

During the baseline measurement phase, the researchers installed advance yield markings to reduce the risk of multiple-threat crashes, which occur when a driver stopping to let a pedestrian cross is too close to the crosswalk, masking the pedestrian from drivers in the adjacent lane. The advance yield markings were typically placed 30 ft in advance of the crosswalk unless a driveway or other issue was present, in which case they could be up to 50 ft. The posted speed limit at the sites ranged from 30 to 40 mph.

The observers scored the percentage of drivers yielding and not yielding to pedestrians. Researchers scored drivers as yielding if they stopped or slowed and allowed the pedestrian to cross. Conversely, researchers scored drivers as not yielding if they passed in front of the pedestrian but would have been able to stop when the pedestrian arrived at the crosswalk.

A recent before-and-after study looked at the effectiveness of RRFBs at an uncontrolled crossing in Garland, Texas (73). The school crosswalk on a five-lane arterial had continental crosswalk markings, supplemented by school crossing signs on either side of the roadway. Prior to installation, city engineers had observed driver compliance with the crosswalk was poor and planned to install overhead and side-mounted rectangular rapid-flashing beacons to improve compliance and facilitate pedestrian crossing maneuvers. In this study, researchers observed

drivers' yielding behavior for crossing-guard-controlled crossings and staged pedestrian crossings, both before and after installation of the RRFBs (see Figure 4). Researchers found that while yielding to school-related crossings with a crossing guard remained fairly constant (with yielding rates around 90 percent), drivers' responses to staged crossings in non-school zone time periods improved from 1 percent before the installation to 80 percent after installation.

**Table 10. Baseline and Follow-up Yielding Data at RRFB Sites in Florida, Illinois, and Washington, D.C. (72).**

Site	Day (Percent)								
	Base	7	30	60	90	180	270	365	730
<b>Florida</b>									
31 <sup>st</sup> Street south of 54 <sup>th</sup> Avenue S	0	54	76	NA	59	NA	91	75	83
4 <sup>th</sup> Street at 18 <sup>th</sup> Avenue S	0	63	72	NA	69	NA	69	80	80
22 <sup>nd</sup> Avenue N and 7 <sup>th</sup> Street	0	97	96	91	93	92	91	98	96
9 <sup>th</sup> Avenue N and 26 <sup>th</sup> Street	0	80	82	85	95	81	88	77	78
22 <sup>nd</sup> Avenue N and 5 <sup>th</sup> Street	8	87	89	92	92	87	96	92	95
Martin Luther King Street and 15 <sup>th</sup> Avenue S	1	86	84	85	82	NA	89	88	88
Martin Luther King Street and 17 <sup>th</sup> Avenue N	0	96	94	80	82	83	88	82	83
1 <sup>st</sup> Avenue N and 13 <sup>th</sup> Street	2	85	87	75	78	NA	91	88	NA
9 <sup>th</sup> Avenue N and 25 <sup>th</sup> Street	0	86	90	83	90	NA	88	81	79
1 <sup>st</sup> Street and 37 <sup>th</sup> Avenue N	0	79	87	85	87	NA	90	97	95
58 <sup>th</sup> Street and 3 <sup>rd</sup> Avenue N	0	85	84	85	85	79	92	82	88
Central Avenue and 61 <sup>st</sup> Street	0	94	95	77	73	72	79	67	72
1 <sup>st</sup> Avenue S and 61 <sup>st</sup> Street	5	68	72	73	75	72	90	72	78
1 <sup>st</sup> Avenue N and 61 <sup>st</sup> Street	0	75	75	68	82	42	76	79	83
83 <sup>rd</sup> Avenue N and Macoma Drive	0	86	93	91	73	88	84	80	90
9 <sup>th</sup> Avenue N and 45 <sup>th</sup> Street	0	54	91	89	90	80	83	77	78
22 <sup>nd</sup> Avenue S west of 23 <sup>rd</sup> Street	0	89	86	78	77	60	75	81	82
62 <sup>nd</sup> Avenue S and 21 <sup>st</sup> Street	0	77	76	77	53	78	81	84	80
9 <sup>th</sup> Avenue N and 31 <sup>st</sup> Street	16	93	95	89	88	82	82	89	NA
<i>Florida Average</i>	2	81	86	82	80	76	86	83	84
<b>Illinois</b>									
Midlothian Road and Kilarny Pass Road	7	62	62	NA	NA	NA	NA	NA	NA
Hawley Street and Atwater Drive	19	71	68	NA	NA	NA	NA	NA	NA
<i>Illinois Average</i>	13	67	65	NA	NA	NA	NA	NA	NA
<b>Washington, D.C.</b>									
Brentwood Road and 13 <sup>th</sup> Street	26	62	74	NA	NA	80	NA	NA	NA
<b>Average Yield (All Sites)</b>	4	78	82	83	80	77	85	83	84
NOTE: NA = data not collected.									



**Figure 4. School Crosswalk with RRFBs in Garland, Texas (73).**

In July 2008, FHWA issued an interim approval for optional use of RRFBs as warning beacons to supplement standard pedestrian or school crossing signs at crosswalks across uncontrolled approaches (74).

A 2009 report by Pécheux, Bauer, and McLeod (75) gave the results of an evaluation of RRFBs at two sites in Miami, Florida. The study team used the following measures of effectiveness to assess the effect of the RRFB on pedestrian and driver behavior: (a) the percentage of pedestrians trapped in the roadway, (b) the percentage of drivers yielding to pedestrians, and (c) the percentage of pedestrian-vehicle conflicts. The researchers found statistically significant improvements in all of the studied MOEs as shown in Table 11. For percent drivers yielding, only 4.2 or 4.1 percent of the drivers yielded at the two sites in the before condition. After the installation of the RRFB, the two sites had over 50 percent increases in yielding to either a 55.2 percent driver yielding or 60.1 percent driver yielding, depending upon the site. The researchers concluded that the RRFB offered clear safety benefits, and it was placed into the category of highly effective countermeasures.

A 2009 report (76) summarized the effects of installing a pedestrian-activated rectangular rapid-flashing beacon at the location of one uncontrolled trail crossing at a busy (15,000 ADT), four-lane urban street in St. Petersburg, Florida. The researchers used a mounted video camera to collect pre- and post-treatment data about pedestrian and driver interactions at the trail crossing. An analysis of the data showed a statistically significant reduction in trail user crossing delay and pedestrian yielding, as well as a statistically significant increase in driver yielding (from 2 percent pretreatment to 35 percent post-treatment and 54 percent when the beacon was activated) and ability of pedestrians to cross the entire intersection (from 82 percent pre-treatment to 94 percent post-treatment).

**Table 11. Measures of Effectiveness for RRFBs with Pedestrian Crossing Signs, Miami, Florida (75).**

Measure of Effectiveness	Site	Before	After	p-value
Percent Drivers Yielding (Staged Crossings, Daytime)	NW 67 <sup>th</sup> and Main Street	4.2 (n=2330)	55.2 (n=2131)	0.01 (daytime and nighttime combined at this site)
	S. Bayshore and Darwin	4.1 (n=2075)	60.1 (n=1361)	0.01 (daytime and nighttime combined at this site)
Percent Drivers Yielding (Staged Crossings, Nighttime)	NW 67 <sup>th</sup> and Main Street	4.4 (n=703)	69.8 (n=223)	See above.
	S. Bayshore and Darwin	2.5 (n=139)	66.0 (n=225)	See above
Percent Drivers Yielding (Resident Crossings)	NW 67 <sup>th</sup> and Main Street	12.5 (n=137)	73.7 (n=259)	0.001
	S. Bayshore and Darwin	5.4 (n=200)	83.4 (n=111)	0.001
Percent of Pedestrians Trapped in Roadway	NW 67 <sup>th</sup> and Main Street	44	0.5	<0.01
Percent of Vehicle-Pedestrian Conflicts	NW 67 <sup>th</sup> and Main Street	11	2.5	<0.05
	S. Bayshore and Darwin	5.5	0	<0.01

A 2011 Oregon Department of Transportation report (77) evaluated RRFB installation at two Bend, Oregon, crosswalks. At the location of the crosswalks, the highway has a 45 mph posted speed limit and is a four-lane roadway with a center median, bike lanes, and sidewalks. Since the posted speed of 45 mph was greater than most locations where RRFBs have been installed in Oregon, the plans for the RRFB installations included additional features to increase the visibility of the crosswalks and the pedestrians and bicyclists using them. These include RRFB assemblies on the side of the road, on the median at the crosswalk, and 500 ft in advance of the crosswalk. Pavement markings included ladder bars with a continental crosswalk, a stop line 50 ft in advance of the crosswalk, and double white solid no-lane-change lines as well as the legend “PED X-ING” on the road as vehicles approach the intersection. The signs in the RRFB assembly were 48 inches, and there was a sign in advance of the crosswalk with the legend “Stop Here for Pedestrians.” Previous to the installation of the RRFBs, motorist yield rates were 23 percent and 25 percent at the intersections; these rates increased to 83 percent at both sites following treatment. The authors (77) concluded that “RRFBs should be considered for installation on high-speed facilities where there are posted speeds greater than 35 miles per hour if there are pedestrians and bicyclists using the facility and a history of crashes or the potential for them.” The authors (77) also suggested the following measures to improve the visibility of the crossing:

- Four pedestrian beacons for each approach for each direction should be installed. Two RRFB assemblies should be installed at the crosswalk (one on the shoulder and one in the median), and two should be installed in advance of the crosswalk (one on the shoulder

and one on the median), based on the minimum stopping sight distance for the actual 85<sup>th</sup> percentile speed. Each assembly should include two beacons, a 36-inch or 48-inch combined bicycle/pedestrian sign that is fluorescent yellow in color. A downward slanting arrow should be added to the assemblies at the crosswalk and an "AHEAD" plaque should be added on the advance assemblies.

- Crosswalks should be enhanced to the greatest extent possible to make drivers aware of the crossing.
- A stop line should be installed for each travel lane 50 ft in advance of the crosswalk. The stop line should be 24 inches wide to clearly define where vehicles should stop to avoid blocking a passing vehicle.
- "Stop Here for Pedestrians" signs should be installed in advance of the marked crosswalks.
- Double white solid no-lane-change lines should be installed at least 150 ft in advance of the crosswalk to deter vehicles from passing a stopping vehicle.
- A legend on the road reading "PED XING" should be installed at the advance sign locations.
- Adequate illumination should be provided at each crosswalk.
- Crosswalks designed as "Z" crossings (a marked crossing at opposite corners of the intersection) should be evaluated before the installation of the RRFBs to determine if crossers use the "Z" crossing or cross straight across.

### *Traffic Control Signal*

The MUTCD defines a traffic control signal as an electronic device that alternately directs traffic to stop and proceed (2). Traffic control signals provide opportunities for pedestrians to cross highways and streets. As a standard, the MUTCD provides nine warrants for signalization. The warrants are:

- Warrant 1, eight-hour vehicular volume.
- Warrant 2, four-hour vehicular volume.
- Warrant 3, peak-hour vehicle volume.
- Warrant 4, pedestrian volume.
- Warrant 5, school crossing.
- Warrant 6, coordinated signal system.
- Warrant 7, crash experience.
- Warrant 8, roadway network.
- Warrant 9, intersection near a railroad grade crossing.

The intentions of Warrant 4 and Warrant 5 are to provide adequate opportunities for pedestrians to cross a major roadway. To apply Warrant 4, the minimum pedestrian volume is 107 pedestrians per hour when the posted speed limit is 35 mph or less. When the posted speed limit is greater than 35 mph, the minimum pedestrian volume is 75 pedestrians per hour. To apply Warrant 5, agencies should attempt other treatments such as crossing guards; however, if other treatments have been attempted and there are more than 20 schoolchildren (elementary through high school students), Warrant 5 may apply (2).

The intentions of Warrants 1, 2, 3, 6, and 8 are to give conflicting traffic flows adequate opportunities to perform turning movements; additionally, signals not meeting the volume warrants may have no operational benefit or may increase delay at the signal. The intention of Warrant 9 is to provide an opportunity to signalize an intersection near a grade crossing when the intersection does not meet any of the other eight warrants. Warrant 7 provides for signalization at locations where crash experience is the primary reason for signalization. The MUTCD stresses use of Warrant 7 when the crashes are those that a signal can correct (2).

For all warrants, the MUTCD recommends evaluating other treatment options prior to the installation of a signal (e.g., pedestrian hybrid beacons, multi-way stop sign control, warning signs, and beacons) (2).

### *Zigzag Lines*

Agencies apply zigzag lines at midblock pedestrian crossings to restrict parking, stopping, and overtaking, which improve pedestrian conspicuity. Zigzag lines are common in New Zealand, Canada, Europe, Trinidad, Great Britain, South Africa, Hong Kong, and Australia. In 2010, a paper reviewed the literature to discuss how different countries use and interpret the meaning of zigzag pavement markings/lines (78). The review indicated most drivers in Trinidad and Australia misunderstood zigzag lines at pedestrian crossings; additionally, some researchers in North America also misunderstood them. Such misunderstanding is associated with frequent vehicles parking, stopping, and overtaking within the vicinity of the pedestrian crossing. There is a need for more education and public information on zigzag lines as a crossing feature.

## **Engineering Treatments – Geometric Design**

### *Barrier – Median*

Placing a barrier in a median is a pedestrian crossing treatment discussed in a review of pedestrian safety research by Campbell et al. (79). The purpose of barriers in the median is to encourage pedestrian crossings at crosswalks by discouraging them at undesirable locations. The HSM does not include median barriers as a pedestrian crash treatment; however, it does indicate the location of roadside features is a treatment with unknown crash effects (6). This indicates a need for more research in this area.

As part of a larger study on pedestrian countermeasures, median fence barriers were installed at two sites: one in Washington, D.C., with a 4-ft fence, and one in New York City with a 6-ft fence (80). At one site, the median fence barrier had two gaps, each located at an intersecting minor street. After installation of the barrier, researchers interviewed pedestrians to gauge their reactions to the treatment. The findings were:

- Regarding crosswalk use, 61 percent of the pedestrians identified the barrier as the reason for using the crosswalk.
- When asked whether the barrier affected the manner in which they crossed the street, 52 percent stated it had no effect and 48 percent indicated the only effect was to force them to cross at the intersection.

- Of those who were crossing midblock before the installation, 61 percent did so out of convenience, with about half of them indicating they would use the crosswalk only if midblock traffic volumes were “very heavy.”
- After installation of the fence, 32 percent of the 22 pedestrians who previously made midblock crossings stated inconvenience as the major factor, with high turning volume at the intersection as a close second (23 percent).
- Older pedestrians were generally concerned with turning traffic at intersections, and many cited recent crash experience as a concern.
- Almost one-quarter of those interviewed indicated they had walked along the median to the end of the barrier, or an opening, before completing the crossing.
- While merchants at a control site indicated they did not anticipate much effect from a median barrier, 58 percent of those at the experimental sites indicated the barrier was discouraging customers from shopping on both sides of the street.
- Most residents accepted the barrier; only 7 percent wanted it removed, with a few complaining about inconvenience and unsightly appearance.

### *Barrier – Roadside and Sidewalk*

A recent FHWA international scan found pedestrian railings were commonly used to direct pedestrian movements to preferred crossing locations in the United Kingdom (at intersections and in median islands) (71). Pedestrian railings also offer a useful guide to pedestrians with visual disabilities. The railings are most common in areas with high pedestrian traffic. Campbell et al. (79) discuss several studies in which chains, fences, guardrails, etc. are used as a means of channelizing and protecting pedestrians (81, 82, 83, 84). The HSM indicates the location of roadside features, of which barriers can be included, has an unknown crash effect (6); this indicates a need for more research in this area.

In one study, researchers evaluated the effect of meter post barriers in Washington, D.C.; New York City, New York; and Toledo, Ohio (80). In this study, meter post barriers were a series of chains connected to consecutive parking meter posts; the barriers were 3 ft high and incorporated as many as three chains. In Washington, D.C., parking meter post barriers were located on one side of the street as a series of six 12-ft single-chain sections. In New York City, meter post barriers were installed on both sides of the street (nine were on one side and ten were on the other); these were 12-ft two-chain sections. In Toledo, Ohio, the meter post barriers consisted of three chains between each post (eight in total); the roadway at this site was a one-way street.

After installation of the meter post barriers, 26 percent of pedestrians crossing at the intersection mentioned their reason for doing so was the legality of doing so elsewhere (i.e., it was illegal to cross elsewhere); in the before period, only 12 percent of the interviewees indicated this. Researchers surmised that the barriers might serve as a reminder that jaywalking is an illegal activity. This study also looked at the perception of merchants along the corridor; of those interviewed, 65 percent perceived no negative effects, 15 percent noted the chains interfered with street crossings, and 18 percent cited problems loading or unloading goods.

In London, a team evaluated barriers placed on both sides of an 1800-ft length of roadway. The barriers included openings on each side of the roadway that were not directly across from each

other (79, 85). In the study, researchers mapped pedestrian movements and combined them with 8 years of crash data. Researchers then compared the crashes-to-exposure ratio at the study site to crashes-to-exposure ratios at 11 sites without pedestrian barriers. The percentage of pedestrians crossing away from the signalized crossing was 7 percent, compared to 18 percent at the other 11 sites.

Using the crash data and pedestrian flow rates (calculated from 4-hour counts), researchers created a ratio of crashes to exposure (called a risk of injury ratio in the document). With the ratio of crashes to exposure for various crossing types, Jacobs (85) calculated relative risk values using the signalized crossings as the base condition. When comparing the roadways without a barrier to the roadway with a barrier, the crashes-to-exposure ratio was approximately equal; however, this did not remain the case for pedestrians crossing outside the signalized crosswalk but within 150 ft of it. In these cases, the relative risk ratio was 11 times greater for the 11 roadways without barriers and 25 times greater for the roadway with a barrier; this was the only statistically significant finding.

In the same study, Jacobs (85) also looked at the longitudinal pedestrian crossing behavior (the distance between gaps in the barrier). Pedestrians were less likely to make crossings away from the intersection when the longitudinal distance was larger. The author suggested having longitudinal distances greater than 30 ft.

In Tokyo, the Japan society of traffic engineers evaluated 18 sections of roadway with pedestrian fences (86). This naive before-and-after study found a decline in crashes of 20 percent, with this result consistent for both crossings in the crosswalk and those outside the crosswalk. Researchers hypothesized the number of crashes in crosswalks might go up while those outside the crosswalk would go down; instead the number of crashes went down for both.

### *Bus Stop Location*

*TCRP Report 125: Guidebook for Mitigating Fixed-Route Bus-and-Pedestrian Collisions* provides information on pedestrian-bus crashes and countermeasures and strategies for reducing these crashes (87). The study recognizes a lack of pedestrian-friendly facilities as a factor in pedestrian-bus crashes. Examples of poor pedestrian facilities include broken and uneven sidewalks, narrow sidewalks, sidewalk obstacles, and a lack of sidewalks or other types of positive separation. There was also a concern over a lack of illumination or lighting.

According to Campbell et al. (79), pedestrian collisions at bus stops make up 2 percent of all pedestrian collisions in urban areas. Most do not involve a pedestrian being struck by a bus; rather, the bus creates a visual screen between automobile drivers and pedestrians crossing in front of the bus. In rural areas, researchers identified pedestrian crashes at school bus stops as 3 percent of all pedestrian crashes. A proposed urban countermeasure is the locating of bus stops on the far side of intersections to encourage pedestrians to cross behind the bus, rather than in front; this allows the pedestrian to see and for oncoming traffic to see the pedestrian.

To determine the effect of bus stop relocation on pedestrian crossing behavior, researchers conducted two before-and-after studies. One site, in Miami, Florida, was at the unsignalized



intersection of a two-way, four-lane roadway and a two-way, two-lane roadway. The other site, in San Diego, California, had a pedestrian signal and was located at the intersection of a two-way, four-lane roadway and a one-way, three-lane roadway (79, 80). Locating the bus stops on the far side of the intersection eliminated the undesired crossing behavior, which had previously been at 50 percent.

An analysis of pedestrian crashes in Sweden concluded officials should increase consideration of pedestrian safety when selecting school bus stop locations (79, 88). The research suggests bus stops should be located such that:

- They are not hidden by vegetation or other obstacles.
- They are away from roadway curves or superelevated locations.
- They provide adequate standing and playing area for the waiting passengers.
- They provide maximum sight distance to all critical elements.

Additional guidance for the location and design of bus stops is provided in TCRP Report 19 (89).

### *Curb Extensions*

The purpose of a curb extension—also known as a choker, curb bulb, or bulbout—is to reduce the width of the vehicle travel way at either an intersection or a midblock pedestrian crossing. It shortens the street crossing distance for pedestrians, may slow vehicle speeds, and provides pedestrians and motorists with an improved view of one another, potentially reducing the risk of a motor vehicle-pedestrian collision. Campbell et al. (79) identify studies that used variations of this treatment in Australia, The Netherlands, and Canada.

In two Australian cities (Keilor, Queensland, and Eltham, Victoria), researchers indicated “curb blisters” had little effect on reducing vehicle speeds (79, 90). However, the findings in Concord, New South Wales, were different. In Concord, researchers compared a subarterial street treated with both curb blisters and marked parking lanes to an untreated street; the comparison showed the crash rate on the treated street was only one-third the crash rate on the untreated street. The authors did not state the number of crashes involving pedestrians, and the study did not compare the streets prior to adding the treatment.

Australia’s “wombat” crossings usually consist of a raised platform with a marked crosswalk on top; additionally, space permitting, they include a refuge island and curb blisters. Thus, they combine features of both speed tables and bulbouts. The goal of the wombat design is to slow motorists, shorten pedestrian exposure to motor vehicles, and increase pedestrian visibility to motorists. According to the research, a wombat crossing generally reduces the 85<sup>th</sup> percentile speed of vehicles by 40 percent (79, 90).

The Dutch towns of Oosterhout and De Meern installed variations of street-narrowing treatments. In Oosterhout, the project consisted of installing two bulbouts that require motorists to deviate from a straight path. After installation of the deviation, the 85<sup>th</sup> percentile vehicle speed and pedestrian conflict rates fell. In De Meern, officials created the path deviation by placing two bulbouts opposite one another, which narrowed the traveled way. At these sites, researchers did not observe a significant reduction in the 85<sup>th</sup> percentile vehicle speed and

received mixed opinions on the treatment. Some concerns over the De Meern treatment were (79, 91):

- Residents did not express a strong sense of neighborhood improvement.
- Swerving cars were thought to endanger bicyclists.
- School teachers thought that children would be confused by the deviation.
- Retailers were concerned about accessibility and parking.
- There was some concern about emergency vehicle access.

Macbeth (79, 92) reported favorable speed changes on five raised and narrowed intersections and seven midblock bulbouts in Canada (two of which were raised bulbouts). In addition to the pedestrian treatments, speed limits were lowered to 19 mph (converted from metric). The results of the speed changes are presented in Table 12.

**Table 12. Speed Changes Due to Bulbouts (79).**

Period	Percent Exceeding		
	19 mph	25 mph	31 mph
Before	86	54	13
After	20	3	2

In 2001, Huang and Cynecki (93) reported the effects of bulbouts on selected pedestrian and motorist behaviors at various locations in Cambridge, Massachusetts, and Seattle, Washington. As shown in Table 13, they found no significant effect on motorists yielding to pedestrians in crosswalks.

**Table 13. Percent of Motorists Yielding to Pedestrians at Bulbout Crosswalks (93).**

Location	Sites	Before	After	Significance
Cambridge, MA	2	20.0 (5)*	66.7 (6)	Small
Seattle, WA	2	57.9 (342)	52.2 (471)	No
* = Sample size in parentheses No = Not significant at 0.10 level Small = Small sample size				

As part of the same study by Huang and Cynecki, they used a treatment-and-control study approach to evaluate four bulbouts in Greensboro, North Carolina, and Richmond, Virginia. Due to low pedestrian activity at the sites, it was necessary to stage pedestrian crossings using a two-person data collection team. Motorists stopped for fewer than 10 percent of the staged pedestrians in both cities. At the 0.10 level, the differences between the treatment and control sites were not statistically significant, as shown in Table 14.

**Table 14. Percent of Motorists Stopping for Staged Pedestrians at Bulbout Crosswalks (93).**

Location	Sites	Treatment	Control	Significance
Greensboro, NC	2	5.2 (211)*	7.6 (185)	N
Richmond, VA	2	0.0 (66)	0.0 (66)	N
* = Sample size in parentheses N = Not significant at 0.10 level				

*Illumination*

At certain locations, site characteristics can make a crosswalk less visible to drivers at night or dusk/day settings. Trees, shadows, glare from nearby buildings, and roadway alignment can all affect the ability of approaching drivers to see a crosswalk or pedestrians who use it. Adding illumination can improve crosswalk and pedestrian visibility, which may improve the safety of such crosswalks. Campbell et al. (79) discuss three studies on illumination in Australia, Israel, and the United States, summarized in the following paragraphs.

Pegrum (79, 94) conducted a two-stage study of pedestrian crossing illumination in Perth, Australia. A pilot study showed sufficient success to initiate a broader-scale lighting program, in which researchers evaluated 63 sites. The illumination consisted of two luminaries (100-watt sodium lamps), one at either end of the crosswalk, on each side of the road; the luminaries were mounted approximately 12 ft from the crosswalk at a height of 17 ft and aimed at a point 3 ft above the pavement. The sodium floodlighting resulted in a significant decrease in nighttime pedestrian crashes; a summary of crashes is shown in Table 15.

Polus and Katz developed and tested a combined illumination and signing system for pedestrian crosswalks in Israel (79, 95). The reported changes in nighttime crashes at the 99 illuminated study sites and 39 not-illuminated control sites are summarized in Table 16, which shows a decrease in nighttime crashes at the study sites and an increase in crashes at the control sites. Daytime crashes were largely unchanged; therefore, the authors concluded the crash reduction was primarily due to the added illumination. Campbell states the authors studied other possible influences—including changes in pedestrian and vehicle flow, weather differences, and national crash trends—but none showed any effect on the results.

**Table 15. Crash Effects of Providing Sodium Floodlights at Pedestrian Crossings in Perth, Australia (79).**

Test	Study Period	Pedestrian Crashes (Fatalities)			Vehicle-Only Crashes (Fatalities)		
		Day	Night	Total	Day	Night	Total
Pilot Test: 6 crossings	5 years before	19 (1)	7 (1)	26 (2)	5 (0)	1 (0)	6 (0)
	5 years after	21 (1)	2 (0)	23 (1)	9 (0)	0 (0)	9 (0)
Follow-Up Test: 57 additional crossings	2 years before	57 (2)	32 (1)	89 (3)	19 (0)	2 (0)	21 (0)
	2 years after	58 (2)	13 (1)	71 (3)	18 (1)	1 (0)	19 (1)

**Table 16. Effects of Crosswalk Illumination on Nighttime Pedestrian Crashes in Israel (79).**

Location (Number of Sites)	Nighttime Crashes	
	Before	After
Illuminated study sites (99)	28	16
Not-illuminated control sites (39)	10	16

In Philadelphia, Pennsylvania, Freedman et al. conducted a study assessing the effects of installing improved lighting at seven sites (79, 96). The effects were evaluated using driver (191 observations) and pedestrian (728 observations) behavior at the study and control sites. The selected study sites were high-crash locations; the control sites were low-crash locations. The illumination consisted of 90-watt low-pressure sodium lamps. Each lamp had a photocell, which energized the circuit at sundown and turned it off at sunrise; experimenters could override the photocell.

In the Philadelphia evaluation, researchers compared five pedestrian attributes: search behavior, crossing path, concentration, erratic behavior, and clothing brightness. According to Campbell's summary (79), the comparison showed "perceived clothing brightness" increased significantly after installing the special illumination. When observing the street in a fashion similar to drivers, observers also perceived the general appearance of pedestrians as brighter. Under all conditions, researchers reported a significant improvement in pedestrian concentration and search behavior. Drivers appeared more aware of approaching crosswalks when the illumination was present. Campbell notes the change in the number of crashes at the study and control sites moved toward the mean; this is expected since the control sites had low crash rates and the study sites had high crash rates in the before period. However, as reported by Campbell, regression to the mean should not influence the behavioral measures.

In a recent Las Vegas, Nevada, study, Nambisan et al. evaluated a midblock crosswalk illumination system with automatic pedestrian detection devices (97). The "smart lighting" system detected the presence of pedestrians who were using the crosswalk and activated additional lighting during their time within the crosswalk. The site had issues with motorists failing to yield and a high proportion of nighttime crashes; officials believed this additional lighting would be more effective at capturing drivers' attention than the use of continuous, high-intensity lighting.

Using a before-and-after methodology, the researchers evaluated the "smart lighting" using two categories of measures of effectiveness: safety MOEs (including pedestrian and motorist behaviors) and mobility MOEs (consisting of pedestrian and vehicle delay). Results show an improvement in safety based upon the MOE values in Table 17 and Table 18. The increase in diverted pedestrians, increase in driver yielding, and decrease in pedestrians trapped in the roadway were statistically significant findings.

**Table 17. Results for “Smart Lighting” Pedestrian Safety MOEs (97).**

MOE	Before (n=44)		After (n=84)	
	Number	Percentage	Number	Percentage
Pedestrians who look for vehicles before beginning to cross	44	100	84	100
Pedestrians who look for vehicles before crossing 2 <sup>nd</sup> half of street	44	100	84	100
Diverted pedestrians	0	0	14	17
Pedestrians trapped in roadway	13	30	12	14

**Table 18. Results for “Smart Lighting” Motorist Safety MOEs (97).**

MOE	Before (n=91)		After (n=116)	
	Number	Percentage	Number	Percentage
Motorists yielding to pedestrians	20	22	41	35
Distance motorist stops/yields before crosswalk (ft)				
0–10	8	40	16	39
10–20	10	50	16	39
>20	2	10	9	22

*Overpasses and Underpasses*

Pedestrian overpasses (bridges) and underpasses (tunnels) allow pedestrians and bicyclists to cross streets while avoiding potential conflicts with vehicles (98). Because they are expensive to construct, agencies should reserve grade-separated crossings for locations with high crossing demand and where the risks of crossing the roadway are high. Ideally, overpasses and underpasses should take advantage of the topography of a site; grade separations are less expensive to construct and more likely to be used if they can help pedestrians avoid going up and down slopes, ramps, and steps.

Campbell et al. discussed several studies of grade separation treatments (79). In Tokyo, Japan, researchers analyzed reported pedestrian crashes for 6 months before and 6 months after the installation of pedestrian overpasses at 31 locations (79, 86). The overall results are shown in Table 19. The table shows data for 656-ft sections and 328-ft sections on either side of each site (converted from metric). Crashes related to the treatment (pedestrian crossing crashes) decreased after installation of the overpasses; however, non-related crashes increased by 23 percent on the 656-ft sections. Additionally, there was a greater reduction in daytime pedestrian collisions than nighttime collisions.

**Table 19. Comparison of Crashes Before and After Installation of Pedestrian Overpasses in Tokyo (79).**

Type of Crash	656-ft sections			328-ft sections		
	Before	After	Reduction	Before	After	Reduction
Related crashes	2.16	0.32	85.1%	1.81	0.16	91.1%
Non-related crashes	2.26	2.77	-22.9%	1.65	1.87	-13.7%
Total	4.42	3.09	29.9%	3.46	2.03	41.1%

The effectiveness of pedestrian overpasses and underpasses depends on their level of use by pedestrians. A 1965 study by Moore and Older found use of overpasses and underpasses depended on walking distances and convenience of the facility (79, 99). They defined a convenience measure (R) as the ratio of the time to cross the street on an overpass divided by the time to cross at street level. The researchers found around 95 percent of pedestrians will use an overpass if the walking time is the same, or better than, the crossing time at street level (i.e.,  $R \leq 1$ ). However, if crossing the overpass takes 50 percent longer than crossing at street level ( $R = 1.5$ ), almost no one will use the overpass. Usage of pedestrian underpasses was not as high as overpasses with similar values of R.

When designing grade-separated crossings, agencies should consider accessibility. Researchers asked a panel of people with disabilities to comment on accessibility issues after using three pedestrian overpasses in San Francisco, California (79, 100). They identified elements that create a barrier or hazard to users with disabilities; the nine major elements are:

- Lack of adequate railings to protect pedestrians from drop-offs on overpass approaches.
- Greater than acceptable cross slopes.
- No level area at the terminals of the ramps on which to stop wheelchairs before entering the street.
- Lack of level resting areas on spiral bridge ramps.
- Railings difficult to grasp for wheelchair users.
- Lack of sight distance to opposing pedestrian flow on spiral ramps.
- Use of maze-like barriers to slow bicyclists on bridge approaches that create a barrier to those who use wheelchairs or who are visually impaired.
- Lack of sound screening on the bridge to permit people with visual impairments to hear oncoming pedestrian traffic and otherwise more easily detect direction and avoid potential conflicts.

In 1980, a study by Templer investigated the feasibility of accommodating pedestrians with physical disabilities on existing overpass and underpass structures (79, 101). A review of 124 crossing structures revealed 86 percent presented at least one major barrier to the physically handicapped, the most common being:

- Stairs only (i.e., no ramps for wheelchair users) leading to an overpass or underpass.
- Ramp or pathway to ramp that is too long and steep.
- Physical barriers along the access paths on the structure.

- Sidewalk on the structure that is too narrow.
- Cross slope on the ramp that is too steep.

Based on cost effectiveness, experts developed and assessed various solutions to these accessibility issues. The Americans with Disabilities Act (ADA) has since required the removal of barriers to wheelchair users, requiring more gentle slopes and periodic level areas for wheelchair users to rest. While these gentle slopes also make it easier for bicyclists and other users, it has greatly increased the length of ramps, which may discourage usage. It is possible to use methods (such as carefully planned fencing) to channel pedestrians to the overpasses and underpasses to increase usage and discourage potentially risky at-grade crossings.

### *Raised Crosswalks*

Using a treatment-and-control study approach, Huang and Cynecki evaluated three raised crosswalks in Durham, North Carolina, and Montgomery County, Maryland (93). All three sites were on two-lane, two-way roadways. In Durham, in addition to the raised crosswalk treatment, one site had a continuously operating overhead flashing beacon. Additionally, staged pedestrians were used at the Maryland site. The researchers found that speeds at the treatment sites were lower than at nearby control sites (Table 20), but driver yielding behavior was mixed (Table 21).

**Table 20. Comparison of Vehicle Speeds at Raised Crosswalks (93).**

Location	50 <sup>th</sup> Percentile Speed (mph)			Significance at 0.05 level or better
	Treatment Site	Control Site	Difference in Speeds	
Durham, NC – Research Drive	20.7	24.7	4.0	Y
Durham, NC – Towerview Drive	11.5	23.9	12.4	Y
Montgomery County, MD	21.5	24.0	2.5	N

NOTES:

- Significance based on two-tailed test.
- Towerview site had an overhead flashing beacon in addition to the raised crosswalk.
- Speeds at the Montgomery County site were measured only when the staged pedestrian was present.

**Table 21. Pedestrians at Raised Crosswalks for Whom Motorists Stopped (93).**

Location	Treatment Site	Control Site	Significance
Durham, NC – Towerview Drive	79.2% (159)*	31.4% (35)	Y (0.000)
Montgomery County, MD	1.2% (169)	1.0% (198)	N

\* = Sample size in parentheses  
 Y = Significant at the 0.10 level or better (p-value in parentheses)  
 N = Not significant at the 0.10 level or better

### *Refuge Islands*

Crossing the street can be a complex task for pedestrians. Pedestrians must estimate vehicle speeds, adjust their walking speeds, determine adequacy of gaps, predict vehicle paths, and time their crossings appropriately. Additionally, drivers must see pedestrians, estimate pedestrian

speeds, determine the need for action, and react accordingly. At night, darkness and headlamp glare make the crossing task even more complex for both pedestrians and drivers (102). When crossings are too wide, pedestrians may not be able to cross during the available gaps without the protection of a signal. By permitting pedestrians to make vehicle gap judgments one direction at a time, median refuge islands simplify the street-crossing task. Recent refuge island designs incorporate an angled or staggered pedestrian opening, which better aligns pedestrians to face the second direction of oncoming traffic. Additionally, it is possible to raise median refuge islands above the street surface or to delineate median refuge islands using markings on the roadway.

In 1994, Bowman and Vecellio compared several kinds of medians, including undivided multi-lane roadways, two-way left-turn lanes, and raised curb medians (79, 103, 104). Raised curb facilities were associated with lower pedestrian crash rates, but the authors reported both raised and TWLTL medians significantly reduced the number and severity of vehicular crashes at the study sites. In general, raised curb medians may be better than TWLTL medians, which in turn, are better than undivided highways, but the literature search did not conclusively find that medians improved pedestrian safety (104).

A study by Bacquie et al. compared median refuge islands and split pedestrian crossovers in an analysis of crash reports at 10 crossing locations in Toronto, Ontario (105). The split pedestrian crossover treatment includes a median refuge island with pedestrian-activated signal control. The crash data were not normalized by exposure data, but some indication was given about pedestrian and vehicle exposure for the two treatments. The study found drivers seldom struck pedestrians standing on the refuge island; poor gap judgment or improper driver yielding behavior caused most crashes. Vehicle rear-end collisions were higher at the split pedestrian crossovers, and researchers surmised it was because it is a less common treatment than traditional intersection signals. The authors indicated that some drivers did not act uniformly when approaching the split pedestrian crossovers, as the drivers may not know when to stop or if other drivers will stop in front of or behind them.

Using a before-and-after study, Huang and Cynecki evaluated five refuge islands in Corvallis, Oregon, and Sacramento, California (93). The Corvallis site was on a four-lane urban arterial with a center left-turn lane, while the Sacramento sites were at the intersection of two-way, two-lane residential streets. The authors reasoned that, because refuge islands constrict the roadway and slow vehicle speeds, the islands would increase the number of motorists yielding to pedestrians. In other words, more pedestrians would have the benefit of motorists yielding to them. However, none of the treatments had a statistically significant effect on driver yielding, as shown in Table 22.

**Table 22. Pedestrians at Refuge Islands for Whom Motorists Yielded (93).**

Location	Sites	Lanes	Before	After	Significance
Corvallis, OR	1	4 + TWLTL	5.7% (35)*	7.5% (53)	Small
Sacramento, CA	4	2	32.6% (46)	42.1% (38)	No
* = Sample size in parentheses					
No = Not significant at 0.10 level					
Small = Small sample size					



At two signalized intersections in San Francisco, California, and a midblock location in Las Vegas, Nevada, officials installed median refuge islands. Pécheux et al. reported no measurable changes in the percentage of pedestrians trapped in the roadway, the percentage of pedestrians diverted to the crosswalk, or the percentage of pedestrian-vehicle conflicts at any of the sites where data for these MOEs were available (54). They also found no significant impacts on drivers' yielding behavior at the intersection locations, but yielding increased significantly at the midblock location, as shown in Table 23. The researchers surmised that the installation of a median refuge island at a midblock location was effective in increasing driver yielding to pedestrians and reducing pedestrian delay, while the median refuge islands at the signalized intersections in San Francisco appeared to be less effective at altering driver and pedestrian behaviors.

**Table 23. Drivers Yielding to Pedestrians at Median Refuge Islands (54).**

Location	Site (Location)	% of Drivers Yielding to Pedestrians		% Change	p-value
		Before	After		
San Francisco	Geary & Stanyan (Intersection)	80.4 (n=158)	86.6 (n=164)	+6.2	0.18
	Geary & 6 <sup>th</sup> (Intersection)	96.1 (n=186)	89.7 (n=262)	-6.4	0.15
Las Vegas	Harmon: Paradise Rd. to Tropicana Blvd. (Midblock)	22 (n=77)	46 (n=284)	+24	<0.001

Pécheux et al. also reported on an offset pedestrian opening (54). The offset is a type of channelization that encourages pedestrians to turn and walk parallel to the traffic they are crossing; it provides refuge for pedestrians in terms of a physical separation from traffic and ensures they are facing the traffic before crossing the second half of the roadway. The crosswalk was created using waist-high bollards and raised medians; the offset at the other study site was developed through median cutouts in an existing raised median, and a new marked crosswalk was added. At both locations, the percent of pedestrians trapped in the roadway fell significantly, particularly at the Lake Mead site with a 57 percent decrease (see Table 24). Researchers suggest the large percentage of pedestrians trapped at the Lake Mead site in the before condition was likely caused by the absence of a marked crosswalk. The research team also measured large, significant increases in driver yielding at both sites as shown in Table 25.

**Table 24. Trapped Pedestrians at Offset Median Openings (54).**

Location	Site	% of Pedestrians Trapped		% Change	p-value
		Before	After		
Las Vegas	Maryland Pkwy & Dumont	12 (n=631)	4 (n=198)	-8	<0.001
Las Vegas	Lake Mead: Belmont to McCarran	62 (n=61)	5 (n=123)	-57	<0.001

**Table 25. Drivers Yielding to Pedestrians at Offset Median Openings (54).**

Location	Site	% of Drivers Yielding to Pedestrians		% Change	p-value
		Before	After		
Las Vegas	Maryland Pkwy & Dumont	32 (n=432)	76 (n=246)	+44	<0.001
Las Vegas	Lake Mead: Belmont to McCarran	3 (n=296)	40 (n=117)	+37	<0.001

*Road Diets*

A road diet involves narrowing (sometimes referred to as lane diets) or eliminating travel lanes on a roadway to accommodate pedestrians and bicyclists. While there can be more than four travel lanes before treatment, road diets are often conversions of four-lane, undivided roads into three lanes—two through lanes plus a center turn lane. Officials may convert the fourth lane to a bicycle lane, sidewalk, and/or on-street parking. Thus, officials reallocate the existing cross-section. A recent Highway Safety Information System report documented an empirical Bayes analysis of road diet installations in Iowa, California, and Washington (106). Researchers estimated the change in total crashes resulting from the conversions in each of the two databases and combined these estimates into a CMF. The EB evaluation of total crash frequency indicated a statistically significant effect of the road diet treatment in both data sets and the combined results. Table 26 shows the results from each of the two studies and the combined results—the CMFs and their standard deviations.

**Table 26. Results of EB Analysis on Four-Lane to Three-Lane Road Diets (106).**

State/Site Characteristics	Crash Type	Number of Treated Sites (Roadway Length)	CMF (Standard Deviation)
Iowa: Predominantly U.S. and state routes within small urban areas (average population of 17,000)	Total crashes	15 (15 mi)	0.53 (0.02)
California/Washington: Predominantly corridors within suburban areas surrounding larger cities (average population of 269,000)	Total crashes	30 (25 mi)	0.81 (0.03)
All Sites	Total crashes	45 (40 mi)	0.71 (0.02)

*Sidewalks*

Tobey et al. investigated the safety effects of sidewalks (107). The researchers found sites with no sidewalks or pathways were the most hazardous for pedestrians, with pedestrian hazard scores of +2.6. These scores indicate crashes at sites without sidewalks are more than twice as likely to occur. Sites with sidewalks on one side of the road had pedestrian hazard scores of +1.2, compared with scores of -1.2 for sites with sidewalks on both sides of the road. Thus, per Tobey et al., sites with no sidewalks were the most hazardous to pedestrians, and sites where sidewalks were present on both sides of the road were least hazardous.

Sidewalks separated from the roadway are the preferred accommodation for pedestrians (108). Providing walkways for pedestrians dramatically increases their perception of the city meeting their needs. The wider the separation is between the pedestrian and the roadway, the more comfortable the pedestrian facility. One study indicated roadways without sidewalks are more than twice as likely to have pedestrian crashes as sites with sidewalks on both sides of the street (108, 109). By providing sidewalks on both sides of the street, communities can reduce the number of midblock crossing crashes.

## Multiple Treatments

In 2009, a paper reported on the effectiveness of engineering countermeasures toward crash reductions at eight corridors within Miami-Dade, Florida (110). Researchers used a before-and-after study to compare the sequential implementation of a 3-year National Highway Traffic Safety Administration (NHTSA) project. The project focused on the education and enforcement components of pedestrian safety; the engineering countermeasure portion was a separate FHWA project looking at specific corridors. Results showed the NHTSA pedestrian safety project reduced countywide pedestrian crash rates by 13 percent along the targeted corridors, and the FHWA engineering safety project produced a further reduction to 50 percent of the baseline level. These results translate to 50 fewer pedestrian crashes annually along the treated corridors. Countermeasures implemented included:

- Reduced minimum green time at midblock crosswalks controlled by a traffic signal.
- Advance yield markings at crosswalks with an uncontrolled approach.
- Recessed or offset stop lines for intersections with traffic signals.
- Leading pedestrian intervals.
- Pedestrian pushbuttons that confirm having been pressed.
- “Turning Vehicles Yield to Pedestrians” symbol signs for drivers.
- Elimination of permissive left turns at a signalized intersection.
- In-street pedestrian signs.
- Pedestrian zone signs.
- Midblock traffic signal.
- Intelligent transportation system video pedestrian detection.
- Rectangular rapid-flashing beacon for uncontrolled multilane crosswalks.
- ITS smart lighting at crosswalks with nighttime crashes.
- ITS “No Right Turn on Red” (NRTOR) signs.
- Pedestrian countdown timers.
- Speed trailer.

In 2005, the Chicago Department of Transportation reported on the effects of a combination of traffic control devices and calming measures used to slow traffic and improve safety around schools (111). These measures included:

- Installation of speed humps along local street frontages of schools.
- Variable speed indicator signs giving interactive speed indication to motorists passing by schools on arterial streets.

- Installation of traditional school crossing warning signs and school zone 20 mph speed limit signs.
- Experimental use of strong yellow/green (SYG) pavement marking materials to mark crosswalks, “SCHOOL” legends, speed humps, centerlines, and stop bars in the blocks adjacent to schools.

The following summary was provided:

“The analysis conducted was limited by the absence of control locations where similar marking treatments might have been installed using standard white pavement marking colors for crosswalks, ‘SCHOOL’ legends, stop bars, and speed hump markings. The program analysis also generally was limited to assessing the combined effect of yellow/green markings, improved signing, and speed humps (on local streets), rather than analyzing the effect of individual traffic control measures. Understandably, it was the City’s intent to maximize the impact on motorists to increase their awareness, slow traffic, and improve overall safety in the school zones, rather than simply conduct a limited experiment on alternating color pattern crosswalks using a combination of white and strong yellow/green pavement marking materials.

The usefulness of the crash analysis was somewhat limited by only having one year of After-condition data available for the 2002 Program installation locations. No After-condition analysis was possible for the 2003 Program locations, nor, obviously, for the 2004 Program schools.

The results of the analysis suggest that the use of strong yellow/green pavement markings did not seem to have a significant effect on traffic speeds or crash experience. On arterial streets, the change in aggregate mean speeds, the aggregate percentage of traffic exceeding the speed limit, and the mode and median values of peak hour 85<sup>th</sup> percentile speeds was minimal. The use of speed indicators, which have proven effective in reducing speeds in other locations throughout the country, did not have a large effect on either speeds or crashes during school peak hours. The combined use of speed indicators and strong yellow/green markings also did not have a major impact on reducing speeds or crashes.

On local streets, the locations studied all had a combination of speed humps and strong yellow/green pavement markings. Most of these locations already had all-way stop control at adjoining intersections, thus already limiting the speeds on those streets. While the change in aggregate mean speeds and the aggregate percentage of traffic exceeding the speed limit was minimal, there did appear to be a reduction in the mode and median values of peak hour 85<sup>th</sup> percentile speeds. However, it seems reasonable to conclude that this reduction may have been largely attributable to the installation of speed humps rather than the yellow/green markings or upgraded school zone signing. This conclusion was reflected by the perception of survey respondents on the relative effectiveness of speed humps versus yellow/green markings.”

The City of Los Angeles, California, has developed what it refers to as a “Smart Pedestrian Warning” system that includes multiple pedestrian crossing treatments (35):

- Advance pavement messages (“PED XING”).

- Advance warning pedestrian signs.
- Extended red curb.
- Double posting of intersection pedestrian signs.
- Ladder-style crosswalk markings.
- Automated pedestrian detection (video imaging).
- Actuated alternating flashing overhead amber beacons.

This pedestrian crossing design and its various elements have evolved over the past several years based on experimentation and testing. To date, Los Angeles has installed approximately 25 pedestrian crossing warning systems. Fisher, in an undated paper that reports on informal evaluations by city engineering staff, indicates this pedestrian warning system has improved driver yielding to pedestrians from 20 to 30 percent to the 72 to 76 percent range (35). Additionally, staff evaluations indicate of the 24 to 28 percent of motorists who do not yield, at least they travel more slowly when approaching the enhanced crossings. For example, limited data indicate the 85<sup>th</sup> percentile vehicle speeds are 2 to 12 mph lower.

## EDUCATION

This section contains a review of pedestrian education treatments. There are three ways of evaluating education treatments. One way of evaluating an education program is by measuring the program's ability to improve user knowledge. A second way is by measuring a program's ability to change user behavior. A third way is by looking at a program's ability to reduce crashes.

To motivate a change in user behavior, an education treatment must answer the user's primary question, "Is it worth changing my behavior?" (5). To answer this question, education programs should focus on a group (or groups) of users and tailor the program to that specific audience (112). Additionally, the program should focus on a limited set of behavioral changes. This means viewing pedestrian education programs as long-term endeavors.

The following sections begin by reviewing the target audiences of education treatments. The next section then looks at education treatments only (programs not associated with increased enforcement or engineering treatments). Following the education treatments only section, this document reviews findings of studies in which increased enforcement accompanied education treatments. After that is a section reviewing studies in which increased enforcement and engineering treatments accompanied education treatments. Because much of the literature pertains to educating children, there is a separate section on the education of children. The final two sections are on translating education materials to non-English languages and the connection between education treatments, behavior, and crashes.

The types of education treatments highlighted in this document are:

- Education of traffic officers.
- Public awareness campaigns.
- Public involvement workshops.
- Curriculum-based education.
- Media-based education.

- One-time instruction.
- Skills-based training.
- Virtual reality.
- WalkSafe.
- Non-English translation of education materials.

## **Education Audience**

Education initiatives seek to motivate changes in public behavior. The question “whom are we trying to educate?” is an important step in the development of an education countermeasure. The Pedestrian and Bicycle Information Center (112) identifies three main groups. Those groups are:

- Road users (e.g., children, college-age students, alcohol consumers, adults, older pedestrians, and drivers).
- Commuters/employees (individuals that could commute to work by walking).
- Transportation officials and decision-makers (people responsible for developing and implementing pedestrian transportation systems).

Effective education programs recognize which group they are targeting and tailor the education program to the selected group. This section documents general information on each of the education audiences.

### *Road Users – Child Pedestrians*

Limited experience, skills, and development complicate the education of children (112). Children rarely consider the safety of their movements and have difficulty judging vehicle speeds and movement. Additionally, crossing a street is a complicated task. While children typically understand the concept of “look left, right, then left,” they have a limited understanding of the subtlety of the message. This means children may go through the motion of looking both ways without evaluating the safety of the crossing they are about to make.

The National Center for Safe Routes to School (113) provides four strategies for educating children. They are:

- One-time instruction.
- Classroom or physical education lessons.
- Parent involvement.
- Structured skills practice.

### *Road Users – College-Age Student Pedestrians*

College-age students are more likely to walk, making them an ideal target for pedestrian safety campaigns; however, college-age students take more risks than other pedestrian groups (112). Programs seeking to educate college students should develop partnerships with campus agencies such as:

- Parking and transportation services.
- Department of public safety.
- Campus health organizations.

- Public health/injury prevention alliances.
- Student associations/groups.

Such programs should take advantage of university events to distribute materials and should provide incentives for students to retain these materials (e.g., give them posters, wristbands, magnets, and coupons). Additionally, to retain student interest, officials should tailor programs to the student population needs and interests.

#### *Road Users – Alcohol Consumer Pedestrians*

According to the Pedestrian and Bicycle Information Center (112), one-third of pedestrian deaths are alcohol related; this statistic includes crashes where the pedestrian was drinking, and it does not include crashes where the driver was drinking and the pedestrian was sober. Public awareness campaigns are a tool for informing pedestrians and motorists of risks associated with walking while impaired. Such campaigns should seek to educate motorists and pedestrians. These education campaigns provide an opportunity to seek partnerships with other organizations, for example, police departments, healthcare officials, and local business owners.

#### *Road Users – Adult Pedestrians*

Pedestrian safety affects road users of all ages, including adult pedestrians, and occasionally the education of adult pedestrians is necessary (112). This is especially true when agencies are implementing new traffic control devices, such as the HAWK. When implementing a new traffic control device, adult pedestrians and drivers need to be aware of how the device operates; therefore, agencies should make efforts to educate the public about the new device. To encourage more walking by pedestrians, and to educate pedestrians on the availability of pedestrian facilities, agencies should highlight pedestrian facilities when introducing infrastructure improvements (5).

#### *Road Users – Older Pedestrians*

Older pedestrians are more fragile than other types of pedestrians, which means older pedestrians are at a greater risk of death or serious injury when hit by an automobile (112). Drivers often strike older pedestrians while they are in a crosswalk. When targeting older pedestrians, agencies should focus on areas where older pedestrians are more concentrated (e.g., retirement communities, healthcare clinics, libraries, and churches). The American Association of Retired Persons (AARP) is a good agency to collaborate with when implementing older pedestrian education treatments.

#### *Road Users – Drivers*

In addition to educating pedestrians, education programs should highlight driver responsibilities for creating a safe driving environment (112). Some options for driver-focused education campaigns are TV, newspaper, commute-time radio talk shows, billboard campaigns, and signs in parking garages. Another option is to distribute driver safety material and pedestrian safety material concurrently; most walkers also drive automobiles, and the two sources of information

will reinforce the message they receive. Agencies can also couple education with enforcement activities, which increase driver knowledge of, and compliance with, pedestrian-related laws.

### *Commuters/Employees*

Communities with transportation demand management programs often initiate commuter/employee education efforts in an attempt to encourage drivers to use other modes of transportation (112). The focus of such campaigns is to convince commuters to walk, bike, or take transit to work. In addition to encouraging people to change modes, these materials could provide guidance on how to do so safely. Some strategies for educating commuters/employees are:

- Hold bicycling and walking events and activities that highlight trails and cycling routes in the community.
- Develop bicycling and walking commuter campaigns with contests to see which organizations have the highest non-automobile mode split.
- Provide and promote bicycle parking, showering, and clothes-changing facilities throughout the community (e.g., at work, transportation terminals, or other destinations).
- Create maps showing recommended routes and facilities in addition to other information pedestrians and bicyclists will find useful.
- Develop tourist information that promotes bicycling and walking.
- Create a multimodal access guide that helps individuals get to various destinations within the community.
- Distribute education materials and programs at events and transportation terminals.

### *Transportation Officials and Decision-Makers*

To be successful, transportation officials and decision-makers must see the value in pedestrian education programs; their support is crucial (112). When educating transportation officials, it is important to show facts through data; this helps officials justify giving attention to pedestrian concerns. Additionally, programs are more likely to be implemented if multiple agencies are working together. For example, transportation agencies can work with transit agencies, public health agencies, and police. Another way of highlighting pedestrian difficulties to transportation officials is to escort them on a walk through the community, pointing out challenges and indicating potential solutions.

In addition to transportation official and decision-maker support, staff support for the pedestrian safety program is important (112). Internal campaigns such as in-house meetings, newsletters, and forums are potential options. Additionally, agencies can use in-house training programs, such as those provided by the Pedestrian and Bicycle Information Center, or other professional organizations, to build agency knowledge in pedestrian safety.

### **Education without Enforcement or Engineering Treatments**

In the literature, engineering and enforcement treatments often accompany education treatments. This section documents instances when this is not the case; that is, this section documents education treatments without enforcement or engineering treatments. The three areas of



education without enforcement are education of traffic officers, public awareness campaigns, and public involvement workshops. Traffic officers' education is discussed in the Enforcement section of this chapter, while examples of the other two topics are provided below.

### *Public Awareness Campaigns*

Public awareness campaigns lay the groundwork for other safety initiatives and increase the likelihood of their success in the future; they also garner support and begin the process of changing public attitudes toward pedestrian safety (5). This literature review contains three examples of public awareness campaigns not accompanied by enforcement or engineering treatments.

**Multi-Agency Program.** In Tucson, Arizona, officials implemented a multifaceted education program to decrease pedestrian injury and fatal crashes (114). The education initiatives included:

- Television and radio public service announcements.
- Educational videos for police training.
- Educational videos for student safety classes.
- Traffic safety guides and maps.
- Maps.
- Posters.
- Helmets.
- Front and rear bicycle light kits.
- Free cycling safety classes for the public.

Officials implemented the program in close coordination with police and safety educators. The program targeted:

- Motorist failure to yield.
- Wrong-way bicycle riding.
- Bicycle helmet use.
- Bicycle light use.
- Red light running (by motorists and bicyclists).
- Speeding.

Overall, the program sought to promote and share the road ethic within the community. The evaluation of the program does not include a statistical evaluation of crashes.

**Private Coalition.** In Toronto, Ontario, an injury prevention coalition implemented an education program with the goal of reducing pedestrian deaths and injuries (114). The public education campaign included an ad campaign, posters, and safety brochures. Results indicate the materials were effective in educating the public and additional people requested brochures and posters; the case does not include crash statistics.

**Public Access Television.** To spread awareness of pedestrian issues, *Perils for Pedestrians* produces monthly, 28-minute public access television episodes highlighting issues affecting pedestrians (114, 115). The program has conducted interviews in all 50 states and in various

other countries. Various jurisdictions have implemented ideas learned from watching the program.

### *Public Involvement Workshops*

Public involvement workshops provide a forum for educating community members. In public involvement workshops, the goal is to provide community members with knowledge they can use to engage in constructive dialogue with transportation professionals and planners. Babka et al. (116) engaged in pedestrian safety workshops in California and documented the community member feedback. The study had a 47 percent evaluation return rate, and more than 90 percent of the responses were positive. Survey responses to an open-response question pertaining to what community members learned were:

- “I have the power to make a change.”
- “There are many things we can do to change our community.”
- “If we work together, we can make the community safer.”
- “Together we can make a difference to make the community more safe and clean.”
- “We can do lots of things for the community knowing how to ask.”
- “How to ask for help. Who to ask for help.”
- “Making contacts with other agencies.”

Babka et al. (116) provide three lessons concerning successful implementation of safety engagement workshops. The first lesson is the need for the community to be ready for this type of public engagement (this includes having city staff with the time, energy, and resources to implement and sustain engagement workshops). The second lesson is the need to reach out to community members and get them to the workshops (without reaching out to community members, the program will not be successful). The third lesson is a need for follow-up activities (these activities demonstrate professional staff and elected officials are committed to community involvement in the planning process).

### **Education with Enforcement**

Engineering and enforcement treatments often accompany education treatments. This section of the literature review documents the results from studies in which officials increased enforcement while implementing education treatments. This literature review contains five studies in which researchers evaluated education treatments with enforcement treatments.

In Amherst, Massachusetts, officials implemented a pedestrian safety education and enforcement program (114). The education program included a public awareness campaign and judicial education. Judicial education involved the police working with judges to ensure judges would not overturn their enforcement of traffic laws in court. The program resulted in reductions in crashes and increases in driver yielding behaviors at targeted locations.

Lobb et al. (117) evaluated the effect of four interventions, one of which was education. Researchers evaluated the four interventions in the following order:

- General communications about rail safety.
- In-school rail safety education.

- Punishment for every unsafe crossing.
- Punishment occasionally for unsafe crossing.

The results indicate no significant change in unsafe crossing behavior with general communication. Researchers did find a significant change in pedestrian behavior when going from general communication to education. The greatest change in pedestrian crossing behavior was with the implementation of punishment for every unsafe crossing intervention. There was no difference between punishment for every unsafe crossing and occasional punishment. The authors conclude enforcement is more effective than targeted education, and enforcement is much more effective than general communications.

In Missoula, Montana, officials implemented an education and enforcement pedestrian safety campaign aimed at drivers and pedestrians (114). The education campaign included street signs, media campaigns, and police stings. Instead of implementing a package developed by the NHTSA, officials decided to work with a consultant and develop their own program; they did this in order to avoid potential backlash anticipated from the national program's dramatic materials. Eighty percent of the safety campaign targeted motorists, which was the same percentage of pedestrian crashes caused by motorists. The police stings involved plain-clothed officers acting as pedestrians in crosswalks; if motorists did not stop, police officers would issue tickets and, in support of the campaign, judges were not lenient in their upholding of these tickets. Officials found anecdotal evidence that drivers were more likely to stop for pedestrians in targeted areas; resources for a statistical analysis were not available.

In Edmonton, Canada, officials implemented an education and enforcement campaign targeting motorists and pedestrians (4). The campaign included a kickoff press conference, radio commercials, newspaper ads, billboards, bridge banners, and bus tails (advertisements on the back of buses). The message provided to motorists was "slow down and be courteous"; the message to pedestrians was "take due care and pay attention when crossing streets." Surveys of the public indicated members of the public were aware of the campaign. The case study did not include crash statistics.

In San Jose, California, officials implemented a program called Street Smarts, which includes targeted enforcement and an expansive education effort (114). The purpose of this campaign was to create fundamental change in the traffic safety culture. The education campaign targeted red-light running, stop sign violations, speeding, school zone violations, and crosswalk safety compliance. Officials selected these targeted behaviors based upon crash statistics. Transportation safety professionals gave safety presentations to neighborhoods interested in the program, along with educational campaign materials (e.g., lawn signs, safety tips, driving quizzes, bumper stickers). A media campaign included radio messages and print articles; additionally, the San Jose Sharks professional hockey team sponsored some of the media efforts. The performance measures for program success are behavioral, and the case study does not include data pertaining to these measures. A survey taken 6 months after the program's initiation indicated citizens felt the program had positively influenced their behavior.

## **Education with Enforcement and Engineering**

Enforcement and engineering treatments often accompany education treatments. This literature review contains three studies in which engineering and enforcement accompanied the implementation of an education treatment; summaries of those three studies are provided in this section.

In Burlington, Vermont, the Department of Public Works implemented an education, engineering, and enforcement campaign aimed at pedestrian and bicycle safety (114). One part of the education component was public service announcements on the radio, on television, and during previews at local cinemas. Another portion of the education component included collaboration with the mayor, police, and local advocacy groups to develop press releases highlighting the safety initiatives. The final portion of the education component was safety coupons, which the public could use to purchase reflective clothing and other safety gear at reduced cost. The case study does not include crash statistics.

In Richmond, British Columbia, Canada, the city delivered a comprehensive pedestrian safety campaign, including education and engineering components (114). The education component included brochures for motorists and pedestrians. The city distributed brochures via city facilities, collaborating agencies (schools and shopping mall kiosks), and conferences with safety foci. The case study indicates the public liked the brochures; however, the document does not indicate the safety effects of the treatment.

In Hamilton Township, New Jersey, officials implemented an engineering, education, and enforcement approach to reducing fatal pedestrian crashes (114). The education component included flyers given to jaywalkers, presentations at schools, presentations at community centers, radio broadcasts, and television commercials. After observing a limited change in jaywalking rates after the implementation of the education program, the township implemented an aggressive enforcement campaign, which included issuing summons to jaywalkers instead of warnings. The number of crashes went down from 10 in 2004 to 2 in 2005 and 2006 (with zero fatalities in 2005 and 2006).

## **Education of Children**

Children are often the focus of education treatments (118). This section documents findings from studies targeting the education of children in pedestrian safety. The methods found are curriculum-based education, media-based education, one-time instruction, skills-based training, virtual reality, and the WalkSafe program.

### *Curriculum-Based Education*

Curriculum-based education is pedestrian safety education that is included in a school's overall curriculum. This literature review contains three studies in which officials implemented, and researchers evaluated, curriculum-based pedestrian safety education.

Livingston et al. (119) found students' pedestrian safety knowledge reverted to baseline values when going between grades for children in kindergarten through third grade. Between third grade and fourth grade, students retained the knowledge; however, the authors concluded the retention might be the result of increased walking experience and not the education training (since older children walk by themselves more often). In this study, the authors did not see a connection between knowledge and improved pedestrian behavior. The authors question the positive effect of pedestrian safety education.

In Orange County, Florida, officials implemented a kindergarten through twelfth grade curriculum addressing pedestrian safety (114). Safety professionals worked with the school board members to develop a curriculum that was age appropriate. The program included in-class curriculum presented by the teacher, posters, videos, and presentations by safety professionals. The case study does not include crash statistics.

After a student-pedestrian crash at a city bus stop in Toledo, Ohio, officials implemented a pedestrian education program in their schools. The program focused on pedestrian behavior around buses. Schools present a 15-minute video to fourth and fifth grade students at the beginning of each school year; middle school age persons narrate the video. The community has not conducted a formal safety evaluation.

### *Media-Based Education*

Media-based education is the education of children through movies, television, and video games. This literature review contains two studies in which researchers evaluated media-based education.

Glang et al. (120) evaluated the use of interactive multimedia to educate children on pedestrian safety skills. To measure the effect of the treatment, researchers evaluated knowledge using computer-delivered video assessment and behavior using real-life street simulation. The authors found that the interactive multimedia program was effective in improving knowledge and that the increase in knowledge translated into improved behavior.

Zeedyk and Wallace (121) evaluated the effectiveness of media-based materials for educating children on pedestrian safety skills. Using a questionnaire, researchers collected baseline and 1-month post-exposure data. Half of the 120 families received the video (treatment group) and the other half did not (control group). The authors found that use of the video in a casual fashion had no effect on parents' or children's knowledge; however, parents believed the video had been effective. This indicates potential false confidence in media-based materials.

### *One-Time Instruction*

One-time instruction (e.g., assemblies) is an opportunity to reach many children quickly, can build school-wide excitement, and is a good way to kick off a pedestrian safety program (113). One-time instruction works best when it is short, visual, age appropriate, engaging, and focused. A downside to one-time instruction is children's limited capacity for retaining the information; therefore, schools should use other means throughout the year to reinforce one-time instruction.

### *Skills-Based Training*

Skills-based training involves providing opportunities for children to practice safe pedestrian behavior in controlled real-world situations. This literature review contains two studies in which researchers evaluate skills-based training.

Barton et al. (122) found skills-based training improved pedestrian behavior in children between 5 and 8 years old. The authors concluded the results demonstrate the potential for short-term improvement from skills-based training.

Berry and Romo (123) used a pre-test/post-test study with control groups to assess an education program's effect on third graders' safety knowledge and self-reported behavior. The authors found individual instructors had a large effect on student-learning outcomes; they attributed this to the unstructured nature of the curriculum. The authors suggest skills-based training may be more effective than classroom instruction; additionally, they caution against widespread implementation of education programs without demonstrated positive results.

### *Virtual Reality*

Virtual reality is an alternative form of skills-based training. An advantage of virtual reality is the range of crossing activities that can be programmed into it. For example, trainers can program scenarios in virtual reality that, in live scenarios, individuals would consider an unacceptable risk to the participants. This literature review contains two studies in which researchers investigated virtual reality as a tool for educating pedestrians.

McComas et al. (124) evaluated the use of a desktop virtual reality program in teaching pedestrian safety. The study used a sample of 95 students with half of them assigned to a control group. The control group watched an unrelated virtual reality program. Researchers observed the children for 1 week before and 1 week after the intervention. The authors found a significant change in the children's performance after the intervention, which indicates the virtual reality experience influenced children's real-world behavior.

In a virtual reality study, Schwebel et al. (125) demonstrated the validity of virtual worlds. In their study, they demonstrated construct validity through correlation between subjects' behavior in the virtual world and their behavior in identical real-world environments. In the study, the authors also demonstrated construct validity, convergent validity, internal reliability, and face validity, which indicates the potential use of virtual reality in the understanding and prevention of pedestrian injuries. Currently, Schwebel and McClure (126) are conducting a study to determine the effectiveness of this technology in training children in safe pedestrian behaviors. The measures of effectiveness they plan to use are temporal gap before initiating crossing, temporal gap remaining after crossing, and attention to traffic while waiting to cross.

## *WalkSafe*

WalkSafe is a curriculum-based education treatment targeting students between kindergarten and fifth grade. This literature review contains three studies in which researchers evaluated implementation of the WalkSafe program in Miami-Dade County, Florida.

Hotz et al. (127) evaluated the implementation of WalkSafe, a school-based safety intervention program, in Miami-Dade County; the target audience was kindergarten to fifth grade students in 16 elementary schools. In addition to the WalkSafe program, the community implemented engineering recommendations and enforcement initiatives. Researchers evaluated the success of the program through a pre-test, a post-test, and a 3-month post-test. The results indicated an improvement in children's pedestrian safety knowledge. Additionally, observational data indicated improved crossing behavior; however, researchers did not distinguish between the behavioral effects of the education treatment versus the behavioral effects of the engineering and enforcement efforts.

In a second study, Hotz et al. (128) evaluated a modified 3-day version of the WalkSafe curriculum. This investigation involved 10,621 students in kindergarten through fifth grade. In addition to testing improvements in children's knowledge, this study also received feedback from teachers responsible for the in-class instruction. The program was effective in improving children's pedestrian safety knowledge. Based on recommendations from teachers and other agencies, officials approved the use of the 3-day version of the WalkSafe program in all elementary schools within Miami-Dade County.

The case study included in the Pedestrian and Bicyclist Information Center Compendium indicates a drop in children admitted to two Level 1 trauma centers in Miami-Dade County (114). The drop was from 93 in 2002 and 2003 to 56 in 2005 and 2006.

## **Non-English Translation of Education Materials**

Texas is a state with a large population whose primary language may not be English. This literature review contains two studies in which researchers evaluated the conversion of pedestrian education materials to non-English languages.

In Amarillo, Texas, officials sought to develop safety education materials for non-English speaking cyclists (114). The program translated Texas SuperCyclist and BikeTexas Safe Routes to School materials into Spanish. Officials found the translated materials help improve collaboration between residents, schools, neighborhood associations, local business, law enforcement, traffic engineers, and transportation departments.

In San Diego, California, officials implemented a public education campaign targeting students whose primary language is not English (114). Officials created bilingual presentations using images and footage from the local community. Using a survey, officials determined the children retained the knowledge presented to them. Additionally, the survey results indicate children believed others were responsible for their safety (parents, older siblings, etc.) and that they

believed cars would always stop for children. This indicates a need to emphasize children taking responsibility for their own safety in future education efforts.

### **Connection between Education and Crashes**

This section contains a review of studies that suggest the connection between education treatments and crashes needs further research. The authors suggest education treatments are capable of changing pedestrian behavior; however, they indicate the relationship between behavioral changes and crashes is not yet established. This suggests a need to establish a relationship between behavioral changes and crashes.

Duperrex et al. (118) reviewed 15 studies that used randomized controlled trials to evaluate pedestrian safety education; 14 of those studies targeted children and one study targeted institutionalized adults. The review found that pedestrian safety education is capable of improving pedestrian behavior; however, the connection between behavior and safety, in terms of crashes, is unknown. Additionally, the authors recommend repeating education programs at regular intervals to combat temporal declines in safety knowledge and safe crossing behavior.

In New Zealand, Roberts et al. (129) questioned the allocation of resources to child pedestrian education. In their study, they estimate spending the resources allocated to child pedestrian education on traffic calming measures would result in 18 fewer child pedestrian hospitalizations. The authors encourage the consideration of the opportunity costs associated with allocating resources to child pedestrian education efforts.

### **ENFORCEMENT**

This section contains a review of enforcement treatments in pedestrian safety. One way of evaluating the effectiveness of an enforcement treatment is by measuring the program's ability to increase compliance with the vehicle code, which includes laws pertaining to pedestrian and motor vehicle right of way. Another is by looking at an enforcement treatment's ability to reduce crashes.

Often, enforcement treatments are in addition to an engineering or education treatment, which complicates measuring the effectiveness of enforcement treatments by themselves. Additionally, sometimes records of enforcement activities are not available or they are too costly to obtain; not having such records makes it difficult to study the effectiveness of enforcement activities (127). Another consideration is the reason that enforcement activities are used; often, the purpose of an enforcement treatment is to address issues at a specific location or along a specific corridor, which complicates rigorous research efforts seeking to look at the effect of enforcement treatments. Despite these limitations, research has connected enforcement to lower crash rates and driver compliance with traffic laws. For example, the HSM contains CMFs for automated enforcement, indicating enforcement has the potential to influence crash frequencies (6).

This section begins by looking at research concerning driver, pedestrian, and police officer understanding of the vehicle code. Following that discussion, this document reviews



enforcement types, and the final section of this document discusses targeted enforcement strategies. The enforcement types and strategies highlighted in this document are:

- Driver and pedestrian vehicle code awareness.
- Police officer vehicle code awareness.
- Targeted routine enforcement.
- High-visibility enforcement.
- Staged crossings with decoy pedestrians (police officers).
- Automated enforcement.
- Education materials in lieu of citations.
- Citations for pedestrian right-of-way violations.
- Fines for pedestrian right-of-way violations.
- Prosecution of pedestrian right-of-way violations.
- Citations after a period of enforcement using education materials.

## **Vehicle Code Awareness**

Research has shown that transportation professionals should not assume police officers, pedestrians, and drivers understand the vehicle code (130, 114). Therefore, research suggests a portion of enforcement activities should focus on increasing driver, pedestrian, and officer awareness of the vehicle code. This section discusses research related to driver, pedestrian, and police officer vehicle code awareness.

### *Driver and Pedestrian Vehicle Code Awareness*

To demonstrate drivers and pedestrians may not understand the vehicle code, Mitman and Ragland (130) asked pedestrians and drivers to indicate who has the right of way (ROW) at intersections with and without marked crosswalks. Additionally, they asked pedestrians and drivers to indicate who has the right of way at midblock locations with and without crosswalks. In California (where the study was conducted), the pedestrian has the right of way at marked and unmarked crosswalks at intersections and at marked midblock locations; conversely, the driver has the right of way at unmarked midblock locations. The results of this study were:

- When all four legs of an intersection had marked crosswalks, 90 percent of pedestrians and 64 percent of drivers were correct.
- When there was no marking at the midblock location, 72 percent of pedestrians and 76 percent of drivers were correct.
- When there was a marked crosswalk at the midblock location, 74 percent of pedestrians and 44 percent of drivers were correct.
- When there were two marked and two unmarked crosswalks at the midblock location, 35 percent of pedestrians and 53 percent of drivers were correct.
- When there were no marked crosswalks at the intersection, 42 percent of pedestrians and 40 percent of drivers were correct.

Based upon the findings of the survey, the researchers suggested that enforcement strategies should focus on enhancing driver and pedestrian knowledge of the laws (130). This means

handing out warnings or educational materials as opposed to, or in addition to, fines. Additionally, they suggest reviewing and changing the laws to increase public understanding.

### *Police Officer Vehicle Code Awareness*

Occasionally, jurisdictions need to update traffic officers' knowledge of pedestrian statutes and their enforcement. In Madison, Wisconsin, after the adoption of a new motorcycle and bicycle law, a young member of the Madison Police Department took the initiative to develop and implement an education program targeting police officers (114). The purpose of the program was to give police officers the knowledge they needed to enforce the new law, which allowed bicyclists and motorcyclists to run red lights after 45 seconds if they were unable to trigger a green indication. In addition to using a DVD to train police officers, officials modified the material for presentation to the public. Police officers and the public found the video to be engaging.

## **Enforcement Types**

This section highlights four types of enforcement. The first is targeted routine enforcement, which are efforts where officers use routine methods to target driver compliance with pedestrian right-of-way violations. The second is high-visibility enforcement, which includes increased enforcement and public media campaigns advertising the increased enforcement. The third type is staged crossings with decoy pedestrians, which are enforcement efforts where officers act as pedestrians and another officer stops motorists not yielding the right of way. The fourth method is automated enforcement, which uses photos or video to enforce red-light compliance, speed compliance, or crosswalk compliance without the need for police officer presence. In addition to the studies below, the section on Education earlier in this chapter contains summaries of enforcement activities that were used in conjunction with education and/or engineering treatments.

### *Targeted Routine Enforcement*

Targeted routine enforcement involves efforts where officers use routine methods to target pedestrian and driver compliance with the vehicle code. Savolainen, Gates, and Datta studied the enforcement of pedestrian compliance with right-of-way laws by two police officers on foot (131). This study looked at enforcement as part of a citywide implementation and implementation on Wayne State University's campus in Detroit, Michigan. For the citywide portion of their study, researchers found a 17 percent reduction in violations during the enforcement, with a sustained improvement of 8 percent for several weeks after the enforcement effort. For the Wayne State University effort, they found a 27 percent reduction in violations during the enforcement period, with a sustained improvement of 10 percent for several weeks after the enforcement effort.

### *High-Visibility Enforcement*

High-visibility enforcement campaigns seek to increase compliance with pedestrian right-of-way laws by increasing enforcement and publicizing the increase in enforcement. In other

transportation-related endeavors, researchers have shown that high-visibility enforcement efforts can be successful (for example, campaigns to decrease drunk driving and increase seat belt usage). However, it has often been difficult to determine the effectiveness of these campaigns, particularly over the long term. A recent report by the Government Accountability Office concluded that further efforts are needed to thoroughly evaluate these programs (132).

### *Staged Crossings with Decoy Pedestrians (Police Officers)*

Staged crossings with decoy pedestrians are enforcement efforts where officers act as pedestrians and another officer stops motorists not yielding the right of way. In Missoula, Montana, police officers performed staged crossings in crosswalks. An officer would step out in front of a vehicle that had plenty of time to stop; if the driver did not stop, an officer on a motorcycle pulled over the driver and issued a ticket (114). To demonstrate the community was serious, officers asked judges not to be lenient in their imposing of the \$140 fines. This enforcement effort was in conjunction with an education campaign. Due to limited resources, the city did not conduct a statistical evaluation; however, anecdotal evidence indicates a positive change in driver behavior.

In Miami Beach, Florida, Van Houten and Malenfant (23) researched the use of decoy pedestrians, feedback flyers, written warnings, verbal warnings, and saturation enforcement. They used four behavioral measures: number of drivers not yielding to pedestrians in crosswalks, number of driver and pedestrian conflicts involving evasive actions, number of pedestrians trapped at the centerline by drivers failing to yield, and percent of drivers yielding more than 10 ft in advance of the crosswalk. In addition to the 2-week intensive enforcement, police conducted maintenance enforcement operations every 6 weeks for a year. During this period, researchers made their observations toward the end of each month. In this study, researchers found that intensive enforcement increased driver yielding and that the maintenance efforts sustained this improvement.

### *Automated Enforcement*

Automated enforcement uses pictures and video to monitor compliance with traffic devices. In a 2008 pedestrian safety report to Congress, the Federal Highway Administration indicated that automated enforcement was a potential means for improving pedestrian safety, through three different options. The first option was automated speed enforcement. Another option was automated red-light enforcement. The final option was automated crosswalk enforcement, which targets vehicles violating pedestrian rights in crosswalks. Of the three types, automated speed and red-light enforcement have been implemented in some U.S. cities; however, means for conducting automated crosswalk enforcement are still being developed and tested (133).

In the United States, the public has resisted automated enforcement of speeding and red-light running; in other industrialized nations using it, such as Australia and nations in Europe, this is not the case (134). Additionally, Zegeer and Bushell (134) recognize that automated enforcement has potential as a pedestrian crash countermeasure. To improve the legitimacy of automated enforcement, they recommend a panel of experts convene to develop a strategy to improve the implementation of automated enforcement.

Additionally, during an international scan tour, American researchers found that experts in European countries seldom mention enforcement strategies without prompting; when European experts do discuss enforcement strategies, they prefer strategies not associated with punitive damages (71). Additionally, when discussing enforcement strategies, the host countries focused on motorist actions as opposed to pedestrian actions (e.g., speeding, red-light running, not yielding at pedestrian crossings). Scan tour participants also found that automated enforcement was common in most countries.

Within the HSM (6), automated enforcement is associated with CMFs. Automated speed enforcement has a CMF of 0.83; this represents a 17 percent reduction in crashes. Automated red-light cameras have a right-angle CMF of 0.74 and a rear-end crash modification factor of 1.18; these represent a 26 percent decrease in the number of right-angle crashes and an 18 percent increase in the number of rear-end crashes. These automated enforcement camera CMFs include reductions in crashes with pedestrians and crashes without pedestrians; this means the crash reduction factors for pedestrian-specific crashes may be different from the values above. The HSM does not provide CMFs associated with automated enforcement and pedestrian crashes.

### **Targeted Enforcement Strategies**

In addition to there being different types of targeted enforcement, there are also different strategies agencies can use with each enforcement type. First, agencies could issue education materials in lieu of citations. Second, agencies can issue citations for traffic code violations. A third option is to increase the fines for pedestrian right-of-way violations. A fourth strategy is to ask prosecutors and judges to uphold citations for pedestrian right-of-way violations (e.g., offer fewer plea bargains and downgrades to lesser violations). A fifth option is to begin an enforcement campaign issuing education material and to later shift to issuing citations or implementing other strategies. This section highlights these strategies for targeted enforcement. In addition to the strategies discussed below, the section on Education earlier in this chapter contains summaries of studies where targeted enforcement was used to increase the effectiveness of engineering and/or education treatments, which is an additional targeted enforcement strategy.

#### *Education Materials in Lieu of Citations*

Since pedestrian compliance with pedestrian right of way could be the result of misunderstanding the vehicle code, issuing education materials in lieu of citations is a possible means for increasing compliance. In Burlington, Vermont, as part of a bicycle and pedestrian safety campaign, the Department of Public Works joined with the mayor and the police department to distribute education materials to violators. The information was specific to the transportation mode (automobiles, bicycles, pedestrians) (114). In this effort, police had an increased focus on bicycle and pedestrian violations in the downtown area. An evaluation of the effect on crashes and compliance was not provided; the campaign has become an annual tradition, which indicates a belief in its effectiveness.

### *Citations for Pedestrian Right-of-Way Violations*

Sometimes increasing driver knowledge of the traffic code is not sufficient to increase compliance; in these cases, officers might need to issue citations. In Hamilton Township, New Jersey, after officials implemented low-cost engineering and education efforts with limited improvement in jaywalking rates, they increased enforcement activities by 600 percent (114). Officials implemented this program in response to 23 pedestrian crashes, resulting in six deaths, between 1998 and 2004 on a single corridor. In these enforcement activities, officers issued summonses instead of warnings. After implementing the enforcement program, there were two pedestrian crashes in 2005 and 2006 combined, with zero fatalities.

### *Fines for Pedestrian Right-of-Way Violations*

Increasing fines for pedestrian right-of-way violations is a method cities can use to demonstrate the importance of compliance with the vehicle code. In Salt Lake City, Utah, following the installation of crosswalk flags, officials modified city ordinances to increase penalties for failure-to-yield violations (114). Specifically, the ordinances target drivers who do not yield for the visibly disabled, school crossing guards, and pedestrians carrying orange flags. Following a violation, drivers faced a recommended fine of \$425; however, the value could range from \$1 to \$750. Based upon 2000 data, the city had a 31 percent reduction in pedestrian injury crashes, attributed to the flags, enforcement, and other safety improvements.

### *Prosecution of Pedestrian Right-of-Way Violations*

Another method for demonstrating the compliance with pedestrian right-of-way laws is to ask prosecutors and judges to be less willing to plea bargain or downgrade failure-to-yield violations. In New Jersey, as part of a statewide pedestrian safety initiative, the governor tasked the attorney general to work with local and county prosecutors to decrease plea bargains and downgrades of failure-to-yield violations to less serious charges (114). The attorney general's goal was to demonstrate that the state is taking pedestrian safety seriously. In addition to increased prosecution, the attorney general has access to \$1.5 million for targeted enforcement efforts. Outside of enforcement and prosecution, the New Jersey State Legislature was considering stronger legislation for the protection of pedestrians. For this effort, results were not available.

### *Citations after a Period of Enforcement Using Education Materials*

As opposed to issuing citations or education materials exclusively, an alternative is to issue warnings for the first part of an enforcement campaign, shifting to citations afterward. At the University of Massachusetts (UMass), UMassSafe (a partnership between the Governor's Highway Safety Bureau and the UMass College of Engineering) worked with the UMass Police Department to implement an education and enforcement campaign (114). In the first month of the program, a plain-clothed officer would radio violations to a nearby cruiser; the cruiser would then stop the violator and issue a warning containing pedestrian safety education materials. In the second month, officers issued tickets with fines ranging from \$35 to \$200. While pedestrian crashes are still occurring, an evaluation showed that more drivers were yielding for pedestrians. Despite an end in funding for the original program, the UMass Police Department continues

performing annual campaigns. A side effect of the program was increased awareness among officers concerning crosswalk violations, which resulted in increased routine enforcement throughout campus.

## **COUNTERMEASURE COSTS**

As shown in previous sections of this literature review, municipalities often implement more than one pedestrian crash countermeasure at a time. Using multiple countermeasures at a site creates challenges with determining the effectiveness of individual treatments and the estimation of their costs. This section contains a selection of funding allocations for pedestrian projects through the Texas Safe Routes to School (SRTS) program. Table 27 contains a summary of minimum and maximum funding levels for different combinations of countermeasures. The following are combinations where Texas Safe Routes to School only funded the given combination once:

- Public information, education, and enforcement – 2007 in Austin, TX – \$567,000.
- Sidewalks, crosswalks, and school zone signs with flashers – 2007 in Hurst, TX – \$571,000.
- Sidewalks, crosswalks, and speed display signs – 2007 in Midland, TX – \$591,000.
- Sidewalks, crosswalks, signs, and speed display signs – 2007 in McAllen, TX – \$566,000.
- Sidewalks and pedestrian signals – 2007 in Bryan, TX – \$283,000.
- Sidewalks, pedestrian bridge, and school zone signs with flashers – 2007 in Walnut Springs, TX – \$410,000.
- Sidewalks, crosswalks, and pavement markings – 2007 in New Braunfels, TX – \$80,000.
- Sidewalks, pedestrian bridge, ramps, signage, and crosswalks – 2010 in Covington, TX – \$266,000.
- Pedestrian/bicycle bridge – 2010 in Palacios, TX – \$23,000.
- Sidewalks, shared use path, and pedestrian bridge – 2010 in Buda, TX – \$500,000.
- School zone flashers installation – 2010 in Horizon City, TX – \$247,000.
- Sidewalks and ADA ramps – 2010 in Horizon City, TX – \$495,000.

## **SUMMARY**

A variety of engineering (e.g., geometric design, traffic control device), education (e.g., public awareness campaigns, curriculum-based education), and enforcement (e.g., high-visibility enforcement, fines for pedestrian right-of-way violation) treatments have the potential to improve safety at pedestrian crossings. To understand the effectiveness of these treatments, researchers in the United States, and in other countries, have conducted various research studies. This chapter summarizes research findings for selected treatments.

**Table 27. Minimum and Maximum Funding Allocations for Pedestrian Projects through Texas Safe Routes to School (113).**

Funded Countermeasures	Minimum Allocation			Maximum Allocation		
	Year	City	Cost (\$1000)	Year	City	Cost (\$1000)
Sidewalks and crosswalks	2007	Grapevine	\$19,000	2007	Taylor	\$574,000
Sidewalks	2007	College Station	\$48,000	2007	Kerrville	\$700,000
Sidewalk, crosswalks, and school zone signs with flashers	2007	Llano	\$161,000	2007	San Angelo	\$750,000
Sidewalks, crosswalks, and signs	2007	Tyler	\$78,000	2007	Rice	\$536,000
Sidewalks, crosswalks, signs, and bike racks	2007	Houston	\$418,000	2007	Houston	\$606,000
Sidewalks, school zone signs with flashers, and bike racks	2010	McAllen	\$287,000	2007	Stanton	\$750,000
Sidewalks, crosswalks, signs, traffic calming, and bike racks	2007	Houston	\$266,000	2007	Houston	\$575,000
Public information and education	2007	Dallas	\$10,000	2007	Carrizo Springs	\$74,000
Sidewalk, ADA ramps, signs, and pavement markings	2008	Haltom	\$272,000	2010	Richland Hills	\$498,000
Sidewalks, ADA ramps, lighted crosswalks, pavement markings	2010	Wichita Falls	\$114,000	2010	Wichita Falls	\$298,000
Sidewalks, crosswalks, curb ramps	2010	Terrell	\$419,000	2010	San Angelo	\$500,000
Shared use path, pavement markings, curb ramps, signage	2010	Heath	\$217,000	2010	Heath	\$294,000
Sidewalks, signage, and pavement markings	2010	Greenville	\$325,000	2010	Greenville	\$425,000
Sidewalks, curb ramps, lighted crosswalks, and bike racks	2010	Edinburg	\$370,000	2010	Edinburg	\$383,000
Shared use path	2010	Troy	\$451,000	2010	Houston	\$500,000
School zone flashers	2010	El Paso	\$80,000	2010	El Paso	\$357,000
Sidewalks, school flashers, signs, widening walkway bridge	2010	El Paso	\$499,000	2010	El Paso	\$500,000
Sidewalks, ADA ramps, intersection crossings	2010	Henrietta	\$489,000	2010	Krum	\$499,000
Sidewalks, ramps, pedestrian bridge improvements, and crosswalks	2010	San Antonio	\$407,000	2010	San Antonio	\$500,000
Develop SRTS program and plan	2007	Marion	\$7000	2007	Pflugerville	\$10,000





## CHAPTER 5

# FUNDING OPPORTUNITIES FOR PEDESTRIAN SAFETY IMPROVEMENTS

### OVERVIEW

This chapter contains a review of the funding options for pedestrian safety efforts. Funding opportunities cover all three Es: engineering, education, and enforcement. Sources of funding for pedestrian safety can be sought from federal, state, local, and non-profit agencies. Infrastructure and non-infrastructure projects are eligible depending on the program purpose and requirements. This section highlights the many opportunities beginning with federal programs; subsequent sections discuss Texas programs, unique state funding programs outside of Texas, and non-profit groups. Since this section was written before the passage of the Moving Ahead for Progress in the 21<sup>st</sup> Century Act (MAP-21), it does not include changes to funding associated with that surface transportation program. The first long-term highway authorization enacted since 2005, MAP-21 was signed into law on July 6, 2012. It provides needed funding and transforms the policy and programmatic framework for investments (135).

### FEDERAL FUNDING

In September of 2011 Congress approved the extension of Safe Accountable Flexible Efficient Transportation Equity Act: A Legacy for Users (SAFETEA-LU) funding through March 31, 2012 (136). SAFETEA-LU legislation had a number of provisions to improve conditions for bicycling and walking; increasing the safety of the two modes remains a high priority for the U.S. Department of Transportation (USDOT). The federal transportation policy spells out specific goals related to walking and bicycling: increase non-motorized transportation to at least 15 percent of all trips and simultaneously reduce the number of non-motorized users killed or injured in traffic crashes by at least 10 percent.

#### **Surface Transportation Environment and Planning Cooperative Research Program (STEP)**

STEP is the sole source of SAFETEA-LU funds available to conduct all FHWA research on planning and environmental issues. The general objective of STEP is to improve understanding of the complex relationship between surface transportation, planning, and the environment. Congress mandated several special studies funded by STEP including the Report on Non-Motorized Transportation Pilot Program. The FY2011 STEP budget totaled \$14.6 million. The FY2012 funding levels are subject to the USDOT appropriations process (137).

#### **Transportation Enhancement (TE) Program**

The TE Program is administered by FHWA, who gives states the responsibility of implementing the program. The program offers funding opportunities to help expand transportation choices and enhance the transportation experience through 12 eligible TE activities related to surface

transportation, including pedestrian and bicycle infrastructure, safety programs, and other programs. In the period between 1992 and 2010, almost 50 percent of the TE Program funding went to building bicycle and pedestrian facilities. Usually a 20 percent match is required by the local agency. Each state has its own procedures for soliciting and selecting projects. Projects must relate to the surface transportation.

Four of the 12 eligible activities include funding for non-motorized transportation: provision of facilities for pedestrians and bicycles, provision of safety and educational activities for pedestrians and bicyclists, landscaping and other scenic beautification, and preservation of abandoned railway corridors (including the conversion and use of the corridors for pedestrian or bicycle trails) (138).

### **Transportation, Community, and System Preservation (TCSP) Program**

Administered by FHWA, the TCSP Program is a comprehensive initiative of research and grants to investigate the relationships between transportation, community, and system preservation plans and practices. States, metropolitan planning organizations, local governments, and tribal governments are eligible for discretionary grants to carry out eligible projects to integrate transportation, community, and system preservation plans and practices that:

- Improve the efficiency of the transportation system of the United States.
- Reduce environmental impacts of transportation.
- Reduce the need for costly future public infrastructure investments.
- Ensure efficient access to jobs, services, and centers of trade.
- Examine community development patterns and identify strategies to encourage private sector development patterns and investments that support these goals.

The following criteria are considered in the evaluation of candidates for this program:

- **Livability** – Priority will be given to requests that address livability, especially from a highway perspective.
  - Operational improvements.
  - Safety improvements.
  - Complete street strategies.
  - Traffic calming.
  - Street connectivity improvements.
  - Reduction of conflicts through access management.
  - Development of livability plans.
- **State of good repair** – This is a project’s ability to improve the condition of existing transportation facilities and systems, with particular emphasis on projects that minimize life-cycle costs.
- **Safety** – This is a project’s ability to improve the safety of U.S. transportation facilities and systems.
- **Expeditious completion of project** – This is a project’s ability to be expeditiously completed within the limited funding amounts available.
- **State priorities** – For states for which more than one project is submitted, consideration is given to the individual state’s priorities.

- **Leveraging of private or other public funding** – Because the requests for funding far exceed the available TCSP funds, commitment of other funding sources to complement the requested TCSP funding is an important factor.
- **Amount of TCSP funding** – The requested amount of funding is a consideration. Realizing the historically high demand of funding under this program and the very limited amount of funding available, modest-sized requests to allow more states to receive funding under this program are given added consideration.
- **National distribution** – This is the national geographic distribution of funding in both urban and rural areas.

The TCSP is an FHWA program jointly developed with the Federal Transit Administration (FTA), the Federal Rail Administration (FRA), the Office of the Secretary, and the Research and Innovative Technology Administration (RITA) within the U.S. Department of Transportation, and the U.S. Environmental Protection Agency (EPA). It is part of the Federal Highway Administration's Discretionary Grants Program. FHWA expects a 20 percent match or sliding scale. An estimated \$29 million was available in 2012 for the call, which closed January 6, 2012 (139).

### **Federal Lands Highway Program**

Administered by FHWA, the Office of Federal Lands Highway (FLH) provides program stewardship and transportation engineering services for planning, design, construction, and rehabilitation of the highways and bridges that provide access to and through federally owned lands. Pedestrian safety project proposals have to show how the project would improve access to public lands. Projects to improve pedestrian safety on high-speed facilities like Interstates are rarely selected. By statute, only state departments of transportation (DOTs) can submit applications to FHWA, though a non-DOT agency may submit an application through the state as a sub-recipient. Project proposals must be consistent with state transportation plans. Part of the FHWA's Discretionary Grants Program, the funding is distributed among the National Park Service regions based on inventory of roads and bridges, deficient miles, traffic volume, and crashes. Approximately \$45 million was available in 2012 (140).

### **The National Scenic Byways Program**

The vision of the Federal Highway Administration's National Scenic Byways Program is "to create a distinctive collection of American roads, their stories and treasured places." The mission is to provide resources to the byway community in creating a unique travel experience and enhanced local quality of life through efforts to preserve, protect, interpret, and promote the intrinsic qualities of designated byways. The U.S. Secretary of Transportation recognizes certain roads as national scenic byways or all-American roads based on their archaeological, cultural, historic, natural, recreational, and scenic qualities. There are 150 such designated byways in 46 states. There are no designated national scenic byways in Texas due to issues concerning property rights and billboards. Therefore, no funding can come to the state as part of this program (141).

## **Transit Enhancement Funds**

The Transportation Equity Act for the 21<sup>st</sup> Century (TEA-21) created the “transit enhancements” provisions in the Urbanized Area Formula Program administered by the Federal Transit Administration. TEA-21 established the requirement that a minimum of 1 percent of the part of FTA’s Urbanized Area Formula Program funding for urbanized areas with populations 200,000 and over must be made available for activities that are transit enhancements. The term “transit enhancement” means projects or project elements that are designed to enhance mass transportation service or use and are physically or functionally related to transit facilities. Landscaping, pedestrian access and walkways, bicycle access, access for persons with disabilities, and transit connections qualify as transit enhancements (142).

In August 2011, a new policy went into effect defining a set radius around a public transportation station or stop in which FTA will consider all pedestrian and bicycle improvements to have a functional relationship to public transportation—pedestrian improvements within 0.5 mile and bicycle improvements within 3 miles of a stop or station. Pedestrian or bicycle improvements outside of the designated radius will still be eligible for funding if the proposed improvements are in areas where people are still walking or biking to public transportation (143).

## **Federal Transit Administration Grants**

The federal government, through the Federal Transit Administration, provides financial assistance to develop new transit systems and to improve, maintain, and operate existing systems. Funding is available through the FTA Job Access Reverse Commute and FTA New Freedom programs. State or local governmental authorities are eligible to apply. Connecting the users to the transit system with sidewalks or other pedestrian safety facilities is an example project.

The FTA Job Access Reverse Commute program supports projects relating to the development and maintenance of transportation services designed to transport welfare recipients and eligible low-income individuals to and from jobs and activities related to their employment, and public transportation projects designed to transport residents of urbanized areas to suburban employment opportunities (144).

The FTA New Freedom program supports projects providing new public transportation services and public transportation alternatives that assist individuals with disabilities with transportation, including transportation to and from jobs and employment support services. In order to be eligible for New Freedom funds, the project must go above and beyond the service required by the Americans with Disabilities Act (145).

## **Alternative Transportation in Parks and Public Lands (ATPPL)**

Facing traffic, pollution, and crowding that diminishes the visitor experience and threatens the environment, national parks, wildlife refuges, and national forests are suffering. The Paul S. Sarbanes Transit in Parks Program is intended to conserve natural, historical, and cultural resources; reduce congestion and pollution; improve visitor mobility and accessibility; enhance

visitor experience; and ensure access to all, including persons with disabilities, through alternative transportation projects. The funds are allocated on a discretionary basis and can be awarded to state governmental authorities with jurisdiction over land in the vicinity of an eligible area. The program is administered by the U.S. Department of Transportation, together with the Department of the Interior and the U.S. Forest Service. The federal share may equal up to 100 percent of project capital or planning costs (146).

### **High-Priority Projects**

Almost \$3 billion is authorized each year for specific projects that are identified in SAFETEA-LU. They are congressionally designated projects. These high-priority projects are federally funded up to 80 percent with a 20 percent match required from non-federal sources (147).

### **Safe Routes to School**

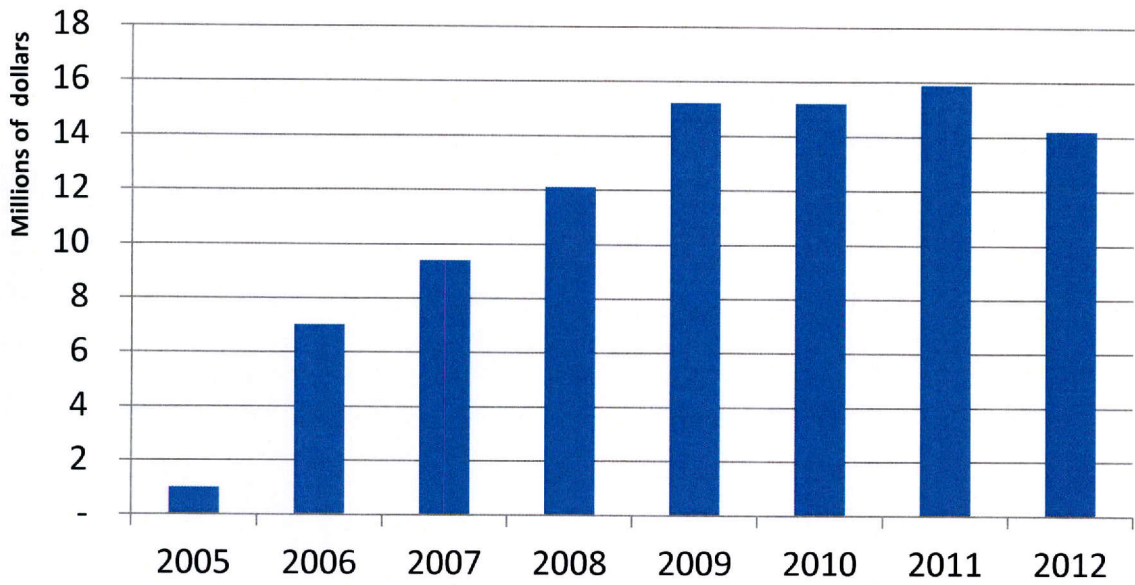
Safe Routes to School funding is available for a wide variety of programs and projects, from building safer street crossings to establishing programs that encourage children and their parents to walk and bicycle safely to school. Although this is a federal program, states are responsible for administering the program. Created by SAFETEA-LU, the program provides funds to substantially improve the ability of primary and middle school students to walk and bicycle to school safely. The purposes of the program are to:

- Enable and encourage children, including those with disabilities, to walk and bicycle to school.
- Make bicycling and walking to school a safer and more appealing transportation alternative, thereby encouraging a healthy and active lifestyle from an early age.
- Facilitate the planning, development, and implementation of projects and activities that will improve safety and reduce traffic, fuel consumption, and air pollution in the vicinity (approximately 2 miles) of primary and middle schools (Grades K–8).

Each state develops its own procedures to solicit and select projects for funding. Both infrastructure projects (engineering improvements) and non-infrastructure-related activities (such as education, enforcement, and encouragement programs) are eligible. See Figure 5 for the amount of Texas' federal SRTS funding per year (148).

### **Surface Transportation Program**

In Texas, TxDOT divides the federal allocations into 12 program categories for roadway maintenance and construction as established by the Texas Transportation Commission. The state then sub-allocates federal funds into two categories: 1) congestion mitigation and air quality (CMAQ), and 2) metropolitan mobility and rehabilitation. The funds are given to MPOs, which are responsible for developing project selection policies, criteria, and processes. The Surface Transportation Program (STP) provides states with flexible funds that may be used for a wide variety of projects on any federal-aid highway including the National Highway System (NHS), bridges on any public road, and transit facilities.



**Figure 5. Texas' Safe Routes to School Apportionment.**

As an exception to the general rule described above, STP-funded bicycle and pedestrian facilities may be located on local and collector roads that are not part of the federal-aid highway system. In addition, bicycle-related non-construction projects, such as maps, coordinator positions, and encouragement programs, are eligible for STP funds (149).

### **Surface Transportation Program – Metropolitan Mobility (STP-MM)**

The STP-MM funding is for projects in areas with populations greater than 200,000. Bicycle and pedestrian improvements are eligible activities under the STP-MM. This covers a wide variety of projects such as on-road facilities, off-road trails, sidewalks, crosswalks, bicycle and pedestrian signals, parking, and other ancillary facilities. The modification of sidewalks to comply with the requirements of the Americans with Disabilities Act is an eligible activity. Known as Category 7, STP-MM funds cover up to 80 percent requiring a 20 percent match (150).

### **Congestion Mitigation and Air Quality Program**

Administered by FHWA and FTA, CMAQ provides funding for areas with non-attainment status and maintenance areas (former non-attainment areas). The funding is provided to state DOTs, MPOs, and transit agencies to invest in projects that reduce air pollutants from transportation-related sources. Pedestrian facilities would qualify as a way to reduce vehicle use or improve traffic flow (151).

### **Section 402 Highway Safety Funds**

Pedestrian safety has been identified as a national priority area and is therefore eligible for Section 402 Highway Safety Funds, which can be used for a variety of safety initiatives including conducting data analyses, developing safety education programs, and implementing community-wide pedestrian safety campaigns. Jointly administered by NHTSA and FHWA,

Section 402 funds can also be used for safety-related engineering projects. At least 40 percent are to be used to address local traffic safety problems. A state is eligible for these grants by submitting an annual Highway Safety Performance Plan (HSPP) for review by the NHTSA. The HSPP must be based on a problem identification process, and establish goals and performance measures based on the identified problems. Countermeasures are selected to achieve the stated goals. Funds are distributed to states based on road miles and population. In 2011, Texas received over \$17 million under this program (152).

### **Highway Safety Improvement Program**

SAFETEA-LU established the Highway Safety Improvement Program in 2005. It replaced the previous set aside of each state's STP apportionment for infrastructure safety activities. HSIP funds can be used for pedestrian and bicycle safety improvements. States may obligate funds under the HSIP to carry out the following (153):

- Any highway safety improvement project on any public road or publicly owned bicycle or pedestrian pathway or trail.
- As provided under flexible funding for states with a strategic highway safety plan, or other safety projects.

### **Recreational Trails Program**

The Recreational Trails Program provides funds to the states to develop and maintain recreational trails and trail-related facilities for both non-motorized and motorized recreational trail uses. Recreational Trails Program funds may be used for:

- Construction of new trails.
- Maintenance and restoration of existing recreational trails.
- Access to trails by persons with disabilities.
- Purchase and lease of trail construction and maintenance equipment.
- Acquisition of land or easements for a trail, or for trail corridors.
- Operation of educational programs to promote safety and environmental protection as related to recreational trails.

In Texas, the Texas Parks and Wildlife Department (TPWD) administers the National Recreational Trails Fund under the approval of FHWA. With funding from a portion of federal gas taxes paid on fuel used in non-highway recreational vehicles, grants can be awarded for 80 percent of project cost with a maximum of \$200,000 for non-motorized trail grants (154).

### **Transportation Investment Generating Economic Recovery (TIGER) Discretionary Grants Program**

The TIGER grant program funds a wide range of innovative transportation projects in urban and rural areas across the country. Projects are awarded on a competitive basis and have a significant impact on the nation, metropolitan area, or a region. Three percent of the funding in TIGER I and 4 percent of funding in TIGER II was spent on exclusive bicycle-pedestrian projects. Seen as excessive amounts directed toward these modes, Congress directed the USDOT to focus the TIGER III program grants on "road, transit, rail, and port projects." That said, bicycle and

pedestrian components are included in larger projects. For example, TIGER III directed more than \$64 million of the \$511 million for Complete Streets projects. Safety, livability, and sustainability are focus areas for TIGER (155).

### **U.S. Department of Energy, Energy Efficiency and Conservation Block Grant Program**

The general purpose of the U.S. Department of Energy, Energy Efficiency and Conservation Block Grant (EECBG) Program is to assist eligible states, units of local government, and Indian tribes in implementing strategies to reduce fossil fuel emissions. Under Category 7: Conservation of Transportation Energy, entities may develop and implement programs to conserve energy used in transportation, including but not limited to:

- Development and promotion of zoning guidelines or requirements that promote energy-efficient development.
- Development of infrastructure such as bike lanes and pathways and pedestrian walkways.
- State/local/regional integrated planning activities (i.e., transportation, housing, environmental, energy, land use) with the goal of reducing greenhouse gas emissions and vehicle miles traveled.

Part of the American Recovery and Reinvestment Act of 2009 (ARRA), the EECBG is part of the formula grants for program years 2009–2013 (156).

## **STATE OF TEXAS FUNDING**

### **Texas Community Development Block Grant (TxCDBG) Program**

As of October 1, 2011, the Texas Department of Agriculture began administering the Texas Community Development Block Grant Program in Texas. The program is dedicated to helping rural Texans strengthen their communities by providing financial and other support for local basic public facilities and infrastructure needs, industries, services and households. Funds are from the U.S. Department of Housing and Urban Development (HUD), provided to small, rural cities with populations less than 50,000 and counties that have a non-metropolitan population under 200,000. The recipients must not be eligible for direct funding from HUD. In 2011, Texas received over \$66 million for this program. The state is responsible for assuring that each project it funds meets one of three national objectives:

- Benefit low- and moderate-income persons.
- Aid in the prevention or elimination of slums or blight.
- Meet a need having a particular urgency, which represents an immediate threat to the health and safety of residents.

The Community Development Fund is the largest fund category in the TxCDBG Program and is the most appropriate for pedestrian safety measures. This fund is available on a biennial basis through a competition in each of the 24 state planning regions. Although most funds are used for public facilities (water/wastewater infrastructure, street and drainage improvements, and housing activities), there are numerous other activities for which these funds may be used. Awards can be as low as \$75,000 and as much as \$800,000 (157).



## **WalkWell Texas**

Initially funded by the TxDOT Traffic Safety Division in 2007, WalkWell Texas focused on decreasing pedestrian fatalities among Texans, ages 55 and older. The organization is part of The Texas Citizen Fund, a non-profit group that partners with other agencies to provide safe, accessible walking and public transportation in Texas communities. The objectives of WalkWell Texas include:

- Understanding pedestrian fatalities among Texans, ages 55 and older, by analyzing the Crash Records Bureau reports generated for each Texas pedestrian death between 2002 and 2005.
- Piloting a pedestrian safety audit tailored to respond to the circumstances, challenges, and experiences of older Texans, particularly in areas where pedestrian fatalities have been identified.
- Working with community partners in counties across Texas to increase the safety of their older residents when walking.

Although no longer seeking funds from TxDOT, Texas Citizen Fund continues its efforts to ensure safe walking for older adults in Texas communities in selected areas (158).

## **STATES OTHER THAN TEXAS**

### **California Pedestrian Safety Assessments (PSAs)**

Offered for free to communities, this program brings experts to assist in conducting assessments of pedestrian conditions, programs, and needs, and suggests new strategies to improve safety. Any city or county can initiate a request for a PSA. The program is funded by a grant from the California Office of Traffic Safety through the National Highway Traffic Safety Administration. The objectives of PSAs are the following (159):

- To improve pedestrian safety in a city or county.
- To create safe, comfortable, accessible, welcoming environments for pedestrians.
- To enhance the walkability and economic vitality of local districts.

A limited number of assessments are available each year.

### **Florida Department of Transportation (FDOT)**

Each year the Highway Safety Grant Program Section of the FDOT Safety Office develops a comprehensive highway safety plan. Project-level concept papers are solicited and received by the Highway Safety Grant Program Section. Priority program areas include grant funding for pedestrian and bicycle safety programs focused on four major categories: 1) legislation, regulation, and policy; 2) enforcement; 3) communication – education and awareness campaigns; and 4) outreach – vulnerable road users (160).

## **Maryland DOT State Highway Administration Transportation Alternatives Program**

The Maryland Department of Transportation's State Highway Administration (SHA) administers the Transportation Alternatives (TA) Program, which is a reimbursable, federal-aid funding program for transportation-related projects. The TA was created under the federal transportation authorization bill, MAP-21, and replaces funding previously made available through the Transportation Enhancement and Safe Routes to School programs. The TA has federal funding available for a variety of alternative transportation projects.

Specifically, TA offers funding opportunities for on-road and off-road facilities for pedestrians, bicyclists, and other non-motorized transportation including sidewalks, bicycle infrastructure, pedestrian and bicycle signals, traffic calming techniques, lighting, and other safety-related infrastructure.

Among the key changes under the TA from previous programs, Maryland has changed some state-driven policy decisions. Maryland now provides opportunities to assist in the funding of design and planning activities for bicycle and pedestrian facilities. Projects will be considered for up to 80 percent of eligible program costs with those providing more than the minimum 20 percent match considered stronger. Eligible project sponsors under the new program include local governments, regional transportation authorities, transit authorities, school districts, and natural resource or public land agencies (161).

## **Massachusetts Executive Office of Public Safety and Security**

The Pittsfield Police Department received a \$7,500 grant from the Massachusetts Executive Office of Public Safety and Security to increase pedestrian and bicycle safety on city streets. The grant funds enforcement of crosswalk laws and education of walkers and bikers, as well as motorists, on how all three can share the road. This award was one of three public safety grants totaling \$159,000 the department recently received (162).

## **NCDOT Division of Bicycle and Pedestrian Transportation and the Transportation Branch**

The North Carolina DOT (NCDOT) created an annual matching grant program called the Bicycle and Pedestrian Planning Grant Initiative to encourage municipalities to develop comprehensive bicycle plans and pedestrian plans. This program is administered through NCDOT's Division of Bicycle and Pedestrian Transportation (DBPT). To date, a total of \$2,969,468 has been allocated to 122 municipalities through this grant program. Funding for the program comes from an allocation first approved by the North Carolina General Assembly in 2003 in addition to federal funds earmarked specifically for bicycle and pedestrian planning through the department's Transportation Planning Branch (163).

## **Washington Traffic Safety Commission**

Washington State is a national leader in traffic safety. The Washington Traffic Safety Commission's vision is to reduce traffic fatalities and serious injuries to zero by 2030 by

following the Target Zero priorities. The commission coordinates Washington's traffic safety efforts in several ways, including the following (164):

- Work with communities and tribes to identify and help resolve traffic safety issues.
- Gather, analyze, and report data on traffic deaths in Washington.
- Distribute state and federal traffic safety funds.
- Conduct public education campaigns.

While the Washington State Department of Transportation (WSDOT) has used hazard elimination funds to support capital and engineering projects focusing on pedestrian safety, the Washington Traffic Safety Commission uses funds from Sections 410, 402, 403, 408, and 405, and other federal sources to address the behavioral side of traffic safety. Under Target Zero, the commission has a competitive grant process once a year.

Requests must be data driven and exhibit a proven strategy or best practice. If not, then a detailed evaluation component must be provided. Only the top two priority levels are considered unless the data identify a pedestrian problem, in which case commission members strongly consider the request. For example, in 2009 they funded a pedestrian program in the City of Spokane at \$25,000 after pedestrian deaths saw an increase from 1 to 13 in just a few months. They invested in media and instituted targeted crosswalk enforcement, which was proven to be effective in reducing pedestrian deaths. Pedestrian deaths remain very low to date.

The overall goal of Target Zero, which began in 2007, is to have zero deaths and disabling injuries in Washington by 2030. The plan has been very successful so far. Only three to four agencies supported the goal initially, and now there are over 125 statewide. Target Zero is a living document that is updated every few years.

Another pedestrian program the commission has begun surrounds school safety and has doubled the minimum fine in schools zones. These fines cannot be waived, suspended, or reduced. Half of the fines collected are placed into the School Zone Safety Account. These funds support crossing guard gear, training, education, equipment for law enforcement to enforce in school zones, signing, and flashing beacons. The program has generated and invested over \$10 million in the past few years. It is a self-supporting program.

## **NON-PROFIT FUNDING**

### **Robert Wood Johnson Foundation (RWJF)**

The Robert Wood Johnson Foundation provides grants for projects in the United States and U.S. territories that advance the mission to improve the health and health care of all Americans. It concentrates its grant making in four goal areas: 1) to assure that all Americans have access to basic health care at reasonable cost; 2) to improve care and support for people with chronic health conditions; 3) to promote healthy communities and lifestyles; and 4) to reduce the personal, social, and economic harm caused by substance abuse. RWJF awards most grants through calls for proposals (CFPs), which are issued from time to time.

The Pioneer Portfolio accepts unsolicited proposals for projects that suggest new and creative approaches to solving health and health care problems. Pioneer welcomes proposals at any time and issues awards throughout the year. Eligible organizations include public agencies, universities, and public charities (165).

### **AARP Foundation Grants Program**

The primary goal of AARP Foundation's grants program is to identify innovative solutions and bring promising practices to scale. Priority is given to solutions addressing the issues of hunger, income, housing, and isolation among low-income, vulnerable adults age 50 and over in the United States. The foundation works with thought leaders, researchers, policy-makers, and organizations who work directly in the field to determine the state of current practice and areas of neglect, and identify potential innovations and solutions. It funds a diverse range of projects that help create long-term, sustainable solutions to the problems faced by low-income adults age 50 and older. The foundation provides 80 to 90 percent of the total project budget. Government agencies can apply for the grant (166).

### **Boltage (Formerly Freiker)**

Boltage is an incentive program that encourages walking and biking to elementary and middle schools by rewarding repetition. Boltage works to make the program cool and develop incentive programs that connect with kids so that walking and biking become a way of life (167).

## **SUMMARY**

Though there are several funding programs at the federal and state levels available for pedestrian safety projects, the challenge is the competition with projects focused on motor vehicles and public transportation. With the exception of the Safe Routes to School and Transportation Enhancements programs where livability projects improving walking and bicycling receive priority, most categories invite projects for motor vehicle travel. Pedestrian and bicycle projects have difficulty competing for many of these funding categories. This chapter provides a review of the funding options for pedestrian safety efforts that cover the three Es of engineering, education, and enforcement, from the federal, state, and local agencies, as well as some non-profit organizations.

## CHAPTER 6

# QUESTIONNAIRE ON PEDESTRIAN SAFETY TREATMENTS

### INTRODUCTION

One of the tasks in this project was to understand the Texas environment related to the installation of pedestrian safety treatments. Practices may vary from city to city or among TxDOT districts; these variations could be related to specific pedestrian-related issues within each jurisdiction, availability of funding, or other factors. As an example, the FHWA Office of Safety recently identified Texas as a pedestrian safety “focus state,” and four cities (Dallas, Fort Worth, Houston, and San Antonio) were identified as “focus cities” ([http://safety.fhwa.dot.gov/ped\\_bike/ped\\_focus/](http://safety.fhwa.dot.gov/ped_bike/ped_focus/)). It is possible that there are variations in crash issues and potential solutions among those four cities, as well as other cities in Texas, and practices may also vary between cities and the TxDOT districts that encompass them.

In light of these items, the research team asked for practitioners’ assistance in documenting current pedestrian treatment practices in Texas, through the use of a set of five questions. The questions asked for information based on practitioners’ professional experience in their respective jurisdictions. Researchers contacted a representative with the TxDOT district and with the city or MPO in each of the following metropolitan areas:

- Austin.
- Dallas.
- Ft. Worth.
- Houston.
- San Antonio.

Of the 10 practitioners contacted, researchers received initial responses from seven, but only four returned a completed set of questions: City of Dallas, City of Ft. Worth, San Antonio MPO, and TxDOT San Antonio District. The following sections describe the answers received from the practitioners. Each of the five questions is listed in its entirety as it was provided to the practitioners, and the respective responses are described accordingly.

### LIST OF QUESTIONS

The five questions asked to practitioners are reproduced below:

1. What are pedestrian safety-related problems that you are currently trying to solve? (Please select all that apply.)
  - Pedestrians crossing at intersections
    - Signalized  Unsignalized/No Beacon  Beacon
    - Right-turning vehicles  Left-turning vehicles  Through vehicles
  - Pedestrians crossing at controlled (e.g., pedestrian signals, pedestrian hybrid beacons) midblock locations
  - Pedestrians crossing at uncontrolled midblock locations
    - Marked crosswalk  No marked crosswalk

- Pedestrians traveling along the roadside (sidewalk, shoulder, etc.)
- School-related pedestrian traffic
- Dart/dash crossings
- Multiple-threat crossings
- Nighttime crashes
- Freeway pedestrian crashes
- Other (please describe): \_\_\_\_\_

2. Please give examples of pedestrian safety treatments that you are currently using in the following three categories:

- Engineering  
\_\_\_\_\_
- Enforcement  
\_\_\_\_\_
- Education  
\_\_\_\_\_

3. What are limitations within your jurisdiction regarding the use/implementation of pedestrian treatments?

4. What treatments have you considered but did not use, and why?

5. What would help you make decisions on the selection and implementation of pedestrian treatments?

## RESPONSES

### Question 1: Pedestrian Safety-Related Problems

The first question asked what current issues practitioners were facing with respect to pedestrian safety. The question provided multiple categories of responses, and practitioners were invited to indicate all of the choices that they had experienced in their jurisdictions.

#### *Intersection Crossings*

All four practitioners responded with at least one issue with intersection-related pedestrian crossings (i.e., right-turning vehicles). The responses are summarized in Table 28.

**Table 28. Intersection-Related Pedestrian Safety Issues.**

Category	City of Dallas	City of Ft. Worth	San Antonio MPO	San Antonio District
<b>Intersection Control</b>				
Signal	X	X	X	
Unsignalized/No Beacon	X	X	X	
Beacon	X			
<b>Vehicle Traffic</b>				
Right-turning vehicles	X	X	X	X
Left-turning vehicles	X			
Through vehicles	X			

*Non-Intersection Locations*

Two cities indicated that pedestrians crossing at controlled midblock locations were a safety issue. For uncontrolled locations, all four respondents said that midblock locations with no marked crosswalk were problem areas, and three of the four indicated the same for midblock locations with marked crosswalks. Three of four respondents (two cities and one TxDOT district) reported problems with pedestrians walking or running along the roadway and being struck from the front or from behind by a vehicle. Two respondents also reported problems with school-related pedestrian traffic. Answers are shown in Table 29.

**Table 29. Pedestrian Safety Issues at Non-Intersection Locations.**

Location	City of Dallas	City of Ft. Worth	San Antonio MPO	San Antonio District
Controlled midblock locations	X	X		
Uncontrolled midblock locations – Marked	X		X	X
Uncontrolled midblock locations – Unmarked	X	X	X	X
Roadside pedestrian traffic	X		X	X
School-related pedestrian traffic	X		X	

*Dart/Dash and Multiple-Threat Pedestrian Crossings*

Dallas and Ft. Worth reported problems with dart/dash pedestrian crossings, where pedestrians walked or ran into the roadway at an intersection or midblock location and were struck by a vehicle. In dart/dash pedestrian crossings, the motorist’s view of the pedestrian may be blocked until an instant before the impact.

Dallas reported problems with multiple-threat crossings, where pedestrians entered the roadway in front of stopped or slowed traffic and were struck by a multiple-threat vehicle in an adjacent lane after becoming trapped in the middle of the roadway.

*Nighttime Crashes and Freeway Pedestrian Crashes*

All three cities reported problems with pedestrian crashes during nighttime conditions. Both respondents from San Antonio affirmed an issue with freeway crashes involving pedestrians.

*Other Issues*

After reviewing the list of issues provided by the research team, the respondents had the opportunity to describe any other issues not already listed. The four respondents described a variety of additional concerns, summarized in Table 30.

**Table 30. Other Pedestrian-Related Safety Problems Not Listed in Question 1.**

<b>Issue</b>	<b>City of Dallas</b>	<b>City of Ft. Worth</b>	<b>San Antonio MPO</b>	<b>San Antonio District</b>
Wide intersections and freeway underpasses	X			
Connectivity and safety for elderly, school, and disabled/motor-assisted wheelchair community	X			
Speeding vehicles		X		
Impaired pedestrians (alcohol or other drugs)		X	X	
Impaired drivers (alcohol or other drugs)		X		
Pedestrians waiting at transit stops			X	
T-intersections				X
Warrants for midblock pedestrian signals are difficult to satisfy				X
Install a signal head and a phase for right turns to insert a gap into vehicular movements for pedestrians to cross a dedicated right-turn lane (especially blind and disabled pedestrians)				X

**Question 2: Examples of Pedestrian Safety Treatments**

The second question asked respondents what pedestrian safety treatments they were currently using, based on three categories: enforcement, engineering, and education. The open-ended question encouraged respondents to provide all relevant treatments for each of the three categories. Responses are summarized in Table 31 for engineering treatments, Table 32 for enforcement treatments, and Table 33 for education treatments.



**Table 31. Pedestrian-Related Engineering Safety Treatments Used by Respondents.**

Treatment	City of Dallas	City of Ft. Worth	San Antonio MPO	San Antonio District
At-grade railroad crossing traffic control and safety standards	X			
Rectangular rapid-flashing beacons	X			
“HAWK signals” (pedestrian hybrid beacons)	X			
New school zone flashers and signage		X		
Bulbouts			X	
Clearance from obstructions			X	
Crosswalks/marked and crosswalk warning signs			X	
Pedestrian indicators/countdown			X	
Pushbutton signals			X	
Refuge islands/medians			X	
Sidewalk buffers			X	
Retrofitting current ADA-compliant ramps into limited ROW or projects designated as sidewalk-only projects without regarding profile to help with retrofit ramps/sidewalks				X

**Table 32. Pedestrian-Related Enforcement Safety Treatments Used by Respondents.**

Treatment	City of Dallas	City of Ft. Worth	San Antonio MPO	San Antonio District
Crosswalk use enforcement	X			
Street-edge barriers in places with recurring automobile-pedestrian conflicts	X			
Ticketing jaywalkers downtown		X		
Higher fines in school zones		X		
Per the memo issued from John Barton, pedestrian accommodations shall be considered when the project is scoped. This has helped significantly with moving forward with the multimodal planning for projects.				X

**Table 33. Pedestrian-Related Education Safety Treatments Used by Respondents.**

<b>Treatment</b>	<b>City of Dallas</b>	<b>City of Ft. Worth</b>	<b>San Antonio MPO</b>	<b>San Antonio District</b>
Bike-ped promotion with visiting guest speakers	X			
Educational materials (e.g., brochures and pamphlets)	X			X
School-based speaking engagements and other outreach	X			
Some training at schools (not comprehensive)		X		
Safety education campaign		X		
Walkable Community Program				X
Safe Routes to School programs in various school districts				X
Walk & Roll Program Events				X
Attendance at local health fairs and public outreach events				X
Member of TxDOT's Traffic Jam Committee				X
Host regional safety committee				X
Bicycle Mobility Advisory Committee				X
Pedestrian Mobility Advisory Committee				X
Pedestrian Safety Action Plan (currently in process of adopting)				X

**Question 3: Limitations on Implementing Pedestrian Safety Treatments**

The third question asked respondents what limitations they may have faced or are facing in their use of pedestrian safety treatments. Available resources were a common theme; three of the four respondents stated that the following were issues that limited their ability to implement treatments that they had considered:

- Funding.
- Implementation costs.
- Staff resources.
- Available right of way.

Other one-time responses included:

- Education and outreach to public/children about proper use.
- Traffic engineers' resistance to midblock crossings.
- Overall priority of pedestrian treatments vs. vehicular mobility.

#### **Question 4: Treatments Considered but Not Installed**

The fourth question asked practitioners what treatments they had considered using within their jurisdictions but did not actually implement. Responses included the following three treatments:

- Illuminated crosswalks: frequent and costly maintenance.
- Separated-grade crossings: high infrastructure cost per square foot, lack of available right of way.
- Midblock crossings: traffic engineers here feel midblock crossings are dangerous, although we do have a few in the city.

#### **Question 5: Additional Useful Information**

The final question asked practitioners what, based on their experience, would enable them to make more informed decisions on pedestrian treatments in the future. The respondents gave a variety of answers:

- Best practices and design standards pertaining to various typical existing conditions and threats.
- Information on anticipated/known impacts of various treatments.
- Institutional adoption of standards and best practices (i.e., organizational coordination protocols and process directives).
- Good criteria on how to evaluate and make a case for innovative pedestrian treatments. Average maintenance costs are important in determining whether we move forward.
- Cost of treatment.
- Crash reduction factor.
- Successful use in other areas.
- Better understanding of ADA requirements.

#### **SUMMARY**

To understand the Texas environment related to the installation of pedestrian safety treatments, the research team sent out a set of five questions to 10 city and TxDOT representatives to document current pedestrian treatment practices in Texas. The five questions were related to the following: 1) pedestrian safety-related problems in their jurisdiction; 2) examples of pedestrian safety treatments used in their jurisdiction; 3) limitations on implementing pedestrian safety treatments in their jurisdiction; 4) treatments considered in their jurisdiction, but not installed; and 5) additional useful information. Of the 10 practitioners contacted, researchers received initial responses from seven, but only four returned a completed set of questions. This chapter discusses responses to the five questions.



## CHAPTER 7

# EXAMINATION OF THE RELATIONSHIP BETWEEN ROADWAY CHARACTERISTICS AND DRIVER YIELDING TO PEDESTRIANS

## INTRODUCTION

### Background

Several traffic control devices are used at pedestrian crossings to improve conditions for crossing pedestrians, including the following:

- Traffic control signal—example shown in Figure 6.
- Pedestrian hybrid beacons—example shown in Figure 7 (close-up photo of a sign located on a mast arm is shown in Figure 8).
- Rectangular rapid-flashing beacons—example shown in Figure 9.

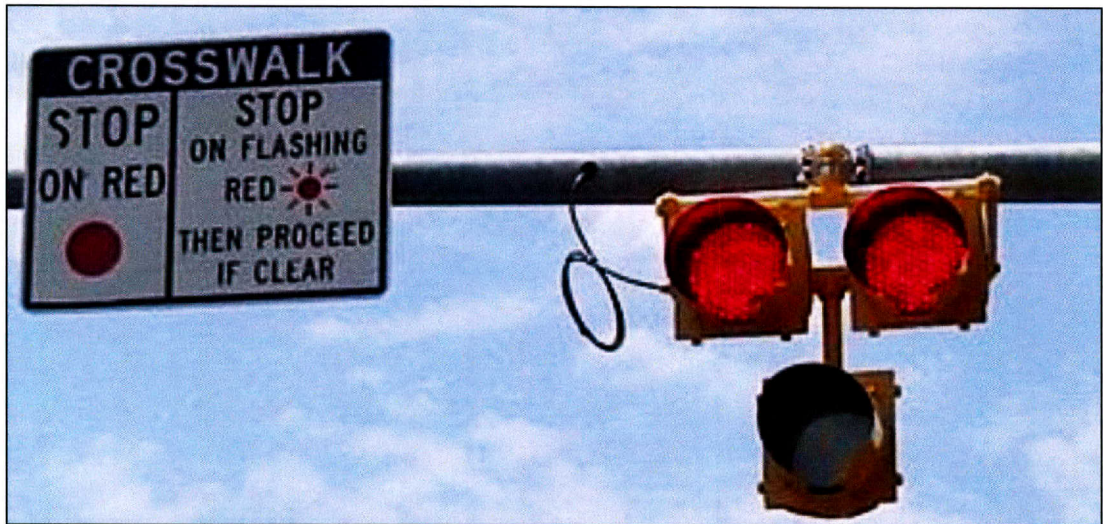
The PHB and RRFB have shown great potential in improving driver yielding rates across the United States (1, 168, 72), and their positive effects at locations in Texas are worthy of further study. In addition, questions have been asked regarding under what roadway conditions—such as crossing distance (number of lanes) and posted speed limit—should each be considered.



**Figure 6. Example of Traffic Control Signal Installation.**



**Figure 7. Example of Pedestrian Hybrid Beacon Installation.**



**Figure 8. Example of a Sign Used with a Pedestrian Hybrid Beacon Installation.**



**Figure 9. Example of Rectangular Rapid-Flashing Beacon with School Crossing Sign Installation.**

Reasons supporting those questions include:

- In many cases, particularly on multilane roads and/or roads with moderate to high speeds, drivers are either not anticipating the presence of crossing pedestrians or choose not to yield when a crossing pedestrian is waiting at the edge of the traveled way.
- Even when a marked crosswalk is present, drivers often fail to yield to pedestrians, behaving as if it is a courtesy rather than a requirement to yield.
- State law essentially requires pedestrians to be in the roadway if they want an expectation that drivers will yield.
- PHBs have been shown to be very effective for driver yielding (1, 168). The RRFBs have also been shown to be effective (72). An evaluation of one site for the RRFB used with a school sign in Garland, Texas, also produced promising results (73).
- However, as with crosswalks, some treatments are more effective at lower speeds and/or on narrower roadways (1).

Additional research to confirm that the positive effects of these pedestrian treatments are also present in Texas, and to identify characteristics that are associated with improved performance, will support the increased use of these pedestrian treatments at similar locations within the state. Increased use of these types of treatments can facilitate the improvement of safe and efficient pedestrian mobility in Texas.

## **Objective**

This research effort is to explore the factors associated with higher driver yielding at pedestrian crossings with TCS, RRFB, or PHB treatments in Texas. The objective of this study was to determine if selected roadway characteristics have an impact on the effectiveness of selected pedestrian crossing treatments as measured by the percent of drivers yielding to a staged pedestrian.

## **FIELD STUDY METHODOLOGY**

The data needed to conduct the analysis for this field study consisted of two primary components:

- Driver yielding at a variety of sites.
- Study site characteristics, particularly posted speed limit and number of lanes or crossing distance.

### **Site Selection**

In an attempt to obtain a reasonable cross section of crossing conditions, researchers desired to visit sites with a variety of characteristics and treatments. Researchers considered the following criteria for study site selection:

- Pedestrian crossing treatment type:
  - Pedestrian hybrid beacon.
  - Rectangular rapid-flashing beacon.
  - Traffic control signal.
- Number of lanes:
  - 2 lanes.
  - 3 lanes.
  - 4 lanes.
  - 5 lanes.
  - More than 5 lanes.
- Posted speed limit:
  - 30 mph.
  - 35 mph.
  - 40 mph.
  - 45 mph.

Ideally, researchers would be able to collect data at multiple sites for each combination of criteria. The availability of sites, however, did not permit an even and extensive distribution of study variables. In some cases, a treatment would rarely if at all be used, such as the case for RRFBs on higher speed and wider cross sections or the use of traffic control signals on lower speed and narrow cross sections. Also restricting the selection of the sites was the limited number of sites with treatments of interest. Both the PHBs and the RRFBs are relatively new devices and are only being used in select cities within Texas.

The researchers enlisted the help of contacts within TxDOT and cities to identify existing sites so that they could collect data at as many varieties of sites as possible. For the traffic control signal sites, the researchers requested suggestions of sites where the signal was installed more for the needs of pedestrians rather than the needs of drivers.

The researchers selected as many sites as feasible within the budget and timeline available for the task. Data were collected at 53 unique crossings with a repeat visit to eight PHB crossings to permit investigation into whether time since installation has an impact on driver yielding. Some



Austin PHB sites had treatments that had been installed for only a short time when researchers first visited the site, so the team revisited these sites later to collect data again after the treatment had been in place for more than a year. Table 34 shows the distribution of the 61 site visits by treatment type, one-way or two-way traffic, number of lanes, and posted speed limit. Two sites are shown with a dual speed limit because the speed limit changed from 35 mph to 40 mph at the approximate location of the pedestrian treatment, resulting in a different speed limit for each direction of vehicular travel.

**Table 34. Distribution of Study Sites by Treatment, Posted Speed Limit, Number of Lanes, and One-Way or Two-Way Traffic.**

One-Way or Two-Way Traffic	Number of Lanes	Posted Speed Limit (mph)	Pedestrian Hybrid Beacon	Rectangular Rapid-Flashing Beacon	Traffic Control Signal	Total
One-Way Traffic	4	30	2			2
		35		3		3
	5	30			1	1
		35		1		1
Subtotal			2	4	1	7
Two-Way Traffic	2	30	8	1		9
		35	2			2
	4	30	2	1		3
		35	7	3	1	11
		35/40	1			1
		40	5	7		12
		45	2	1		3
	5	40	1	1		2
		45		1		1
	6	35			3	3
		35/40	1			1
		40	1	3	2	6
	Subtotal			30	18	6
Grand Total			32	22	7	61

### Site Characteristics

In conjunction with collecting driver yielding data, researchers also documented the characteristics of each study site. Information was primarily collected from aerial photographs. This information was supplemented by researchers’ annotations on aerial photographs of each site and digital pictures researchers took of each vehicular and pedestrian approach to the crosswalk, the crosswalk itself, the crossing treatment, and any other notable features at the site. All information was compiled into a database for use in the analysis.

A summary of the study site characteristics is shown in Table 35 for pedestrian hybrid beacon sites, Table 36 for rectangular rapid-flashing beacon sites, and Table 37 for traffic control signal sites.

**Table 35. Pedestrian Hybrid Beacon Sites.**

Site	Posted Speed Limit (mph)	Number Through Lanes	City	One- or Two-Way	Median Type	Total Crossing Distance (ft)	Days Since PHB Installation
A-02-1	35	4	Austin	two	None	48	117
A-02-2	35	4	Austin	two	None	48	421
A-03-1	30	4	Austin	two	None	40	484
A-03-2	30	4	Austin	two	None	40	783
A-05-1	30	4	Austin	one	None	55	515
A-06-1	30	4	Austin	one	None	58	515
A-07-1	35	4	Austin	two	Raised	57	834
A-08-1	35	4	Austin	two	Raised	68	467
A-09-1	30	2	Austin	two	TWLTL	45	106
A-09-2	30	2	Austin	two	TWLTL	45	406
A-10-1	40	4	Austin	two	Raised	68	130
A-10-2	40	4	Austin	two	Raised	68	428
A-12-1	40	4	Austin	two	Raised	68	130
A-12-2	40	4	Austin	two	Raised	68	428
A-13-1	35	4	Austin	two	TWLTL	66	375
A-14-1	40	4	Austin	two	TWLTL	58	470
A-16-1	35	4	Austin	two	TWLTL	60	884
A-17-1	30	2	Austin	two	None	45	489
A-17-2	30	2	Austin	two	None	45	789
A-19-1	30	2	Austin	two	None	45	411
A-19-2	30	2	Austin	two	None	45	712
A-20-1	40	5	Austin	two	Raised	84	1044
A-22-1	45	4	Austin	two	TWLTL	68	77
A-22-2	45	4	Austin	two	TWLTL	68	381
A-24-1	35	4	Austin	two	Raised	68	194
H-01-1	30	2	Houston	two	TWLTL	30	unknown
H-02-1	40	6	Houston	two	Raised	92	unknown
H-07-1	35	2	Houston	two	None	20	unknown
H-10-1	35	2	Houston	two	Raised	60	unknown
SA-01-1	35/40	6	San Antonio	two	TWLTL	84	95
W-01-1	35/40	4	Waco	two	TWLTL	64	388
W-06-1	30	2	Waco	two	None	44	45

**Table 36. Rectangular Rapid-Flashing Beacon Sites.**

Site	Posted Speed Limit (mph)	Number Through Lanes	City	Sign* Location	One- or Two-Way	Median Type	Total Crossing Distance	Days Since Install
FR-01	45	5	Frisco	Roadside	two	Raised	120	35
GA-01	40	5	Garland	Roadside	two	Raised	83	119
GA-02	40	4	Garland	Roadside	two	Flush	65	119
GA-03	35	4	Garland	Overhead	two	None	52	62
GA-04	35	4	Garland	Overhead	two	TWLTL	72	62
GA-05	40	6	Garland	Roadside	two	Raised	81	71
GA-06	40	4	Garland	Roadside	two	Raised	90	119
GA-07	45	4	Garland	Roadside	two	Raised	84	118
GA-08	40	4	Garland	Overhead	two	Raised	53	59
GA-09	40	4	Garland	Overhead	two	None	44	59
GA-10	40	4	Garland	Roadside	two	Raised	82	119
GA-11	40	4	Garland	Roadside	two	Raised	76	118
GA-12	40	6	Garland	Roadside	two	Raised	90	118
GA-13	40	4	Garland	Roadside	two	Raised	74	119
GA-14	35	4	Garland	Overhead	one	None	44	62
GA-15	35	4	Garland	Overhead	one	None	44	62
GA-16	35	4	Garland	Overhead	one	None	44	62
GA-17	35	5	Garland	Overhead	one	None	44	62
GA-18	35	4	Garland	Overhead	two	TWLTL	76	13
GA-19	40	6	Garland	Roadside	two	Raised	99	19
W-02	30	2	Waco	Roadside	two	Flush	38	unknown
W-04	30	4	Waco	Roadside	two	TWLTL	61	29

\*All sites had school crossing signs.

**Table 37. Traffic Control Signal Sites.**

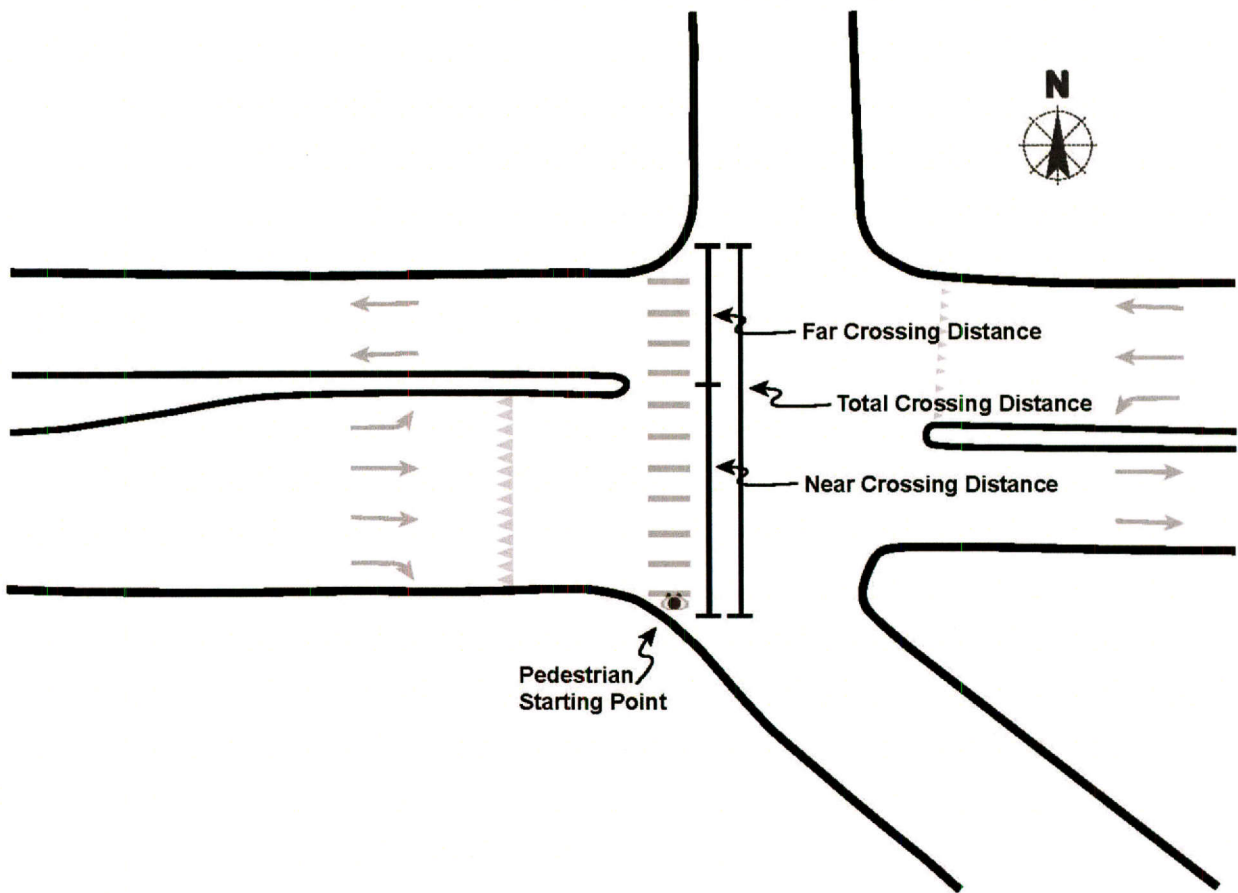
Site	Posted Speed Limit (mph)	Number Lanes	City	One- or Two-Way	Median Type	Total Crossing Distance
A-40	35	4	Austin	two	None	38
DA-07	35	6	Dallas	two	Raised	82
DA-11	40	6	Dallas	two	Raised	80
DA-12	35	6	Dallas	two	Raised	95
DA-14	40	6	Dallas	two	Raised	80
H-05	35	6	Houston	two	Raised	79
H-06	30	5	Houston	one	None	50

All the RRFB sites had school crossing signs with the rectangular rapid-flashing beacon. While there are some RRFB sites in Texas with pedestrian crossing signs, all sites used in this analysis had school crossing signs. The FHWA interim approval (169) for the RRFB states that when used, two pedestrian or school crossing signs shall be installed at the crosswalk, one on the right-hand side of the roadway and one on the left-hand side of the roadway. On a divided highway, the left-hand side assembly should be installed on the median, if practical, rather than on the far left side of the highway. A later interpretation (170) indicated that overhead mounting is appropriate, and that if overhead mounting is used, only a minimum of one such sign per approach is required and it should be located over the approximate center of the lanes of the approach. Within Garland, some of the sites had the school crossing signs located over the roadway on a mast arm along with the roadside installation (example shown in Figure 9). The overhead placements were used on undivided roadways (e.g., roadways with four lanes and a two-way, left-turn lane) or multi-lane, one-way roads. The side mounts were used on divided roadways when the second sign could be placed in the median. Garland was concerned that the RRFB would be outside the cone of vision or that it could easily be obscured by a truck going in the opposite direction when located on the left side of an undivided roadway. The medians on the divided roadways allow a left-side installation next to traffic going in that direction. When the median was less than 4 ft as was the case for GA-08, the city used an overhead installation.

Using number of lanes in the evaluation would capture an appreciation of the crossing distance; however, it may not accurately consider the presence of features that could lengthen a crossing trip for a pedestrian. The presence of a bike lane or a large curb radius can sizably increase the amount of distance (and time) a pedestrian is on the roadway pavement. Therefore, the crossing distance from curb to curb was also measured for the following conditions:

- Nearside crossing distance – measured from curb to refuge area or to the edge of the traveling lane going in the same direction.
- Farside crossing distance – measured from the end of the nearside crossing distance to the curb.
- Total crossing distance – measured from curb to curb.

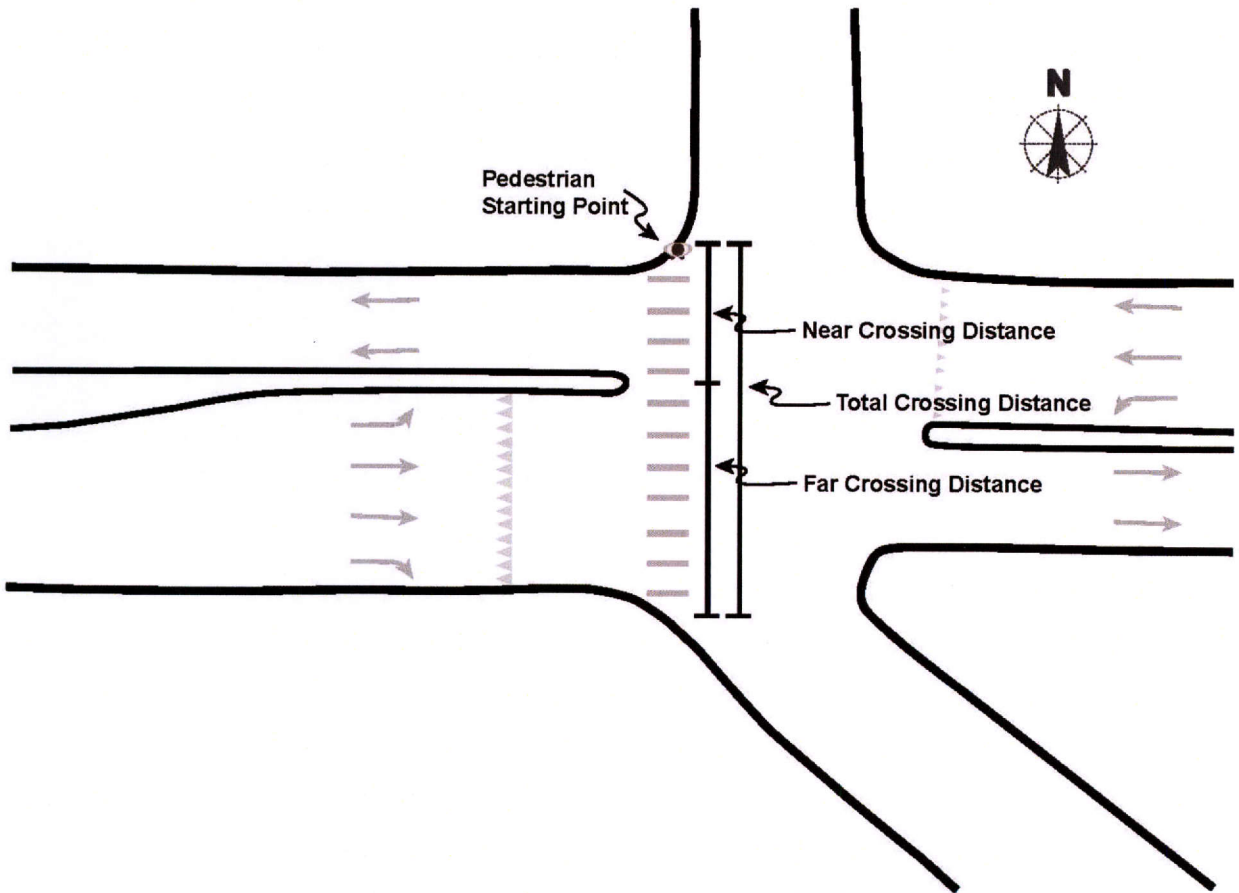
Figure 10 shows examples of the crossing distance measurements when crossing from south to north. Figure 11 shows distances when crossing from north to south. As illustrated in the figures, the nearside and farside crossing distances are a function of which direction the pedestrian is traveling at the crossing. For the example in Figure 10 when the pedestrian is crossing from the south to the north (assuming north is at the top of the figure), the nearside crossing distance would include the distance due to the curb radius, a right-turn lane, two through lanes, and a left-turn lane for a total nearside distance of about 50 ft. When the pedestrian is crossing from the north to the south, the nearside crossing distance would include the distance due to the curb radius and two through lanes for a total nearside distance of about 30 ft.



**Figure 10. Example of Crossing Distance Measurements, Going from South to North.**

Data reduction was modified to permit the identification of the direction the staged pedestrian was moving (i.e., northbound or southbound) because crossing distance is a function of this direction. The crossing data were then matched to the appropriate nearside or farside crossing distance along with the total crossing distance.

Another variable gathered after data collection occurred was the date of installation of the treatment. A previous study (72) has explored whether compliance changed based upon how long the device had been installed. The change in compliance could be a decrease in effectiveness due to an initial “honeymoon” phase with drivers being more responsive to the “new” device and later becoming more complacent and not as willing to yield. On the other hand, compliance could improve as drivers become more familiar with the device and learn what is expected of them when the device is active. To be able to explore if driver yielding changes based on length of time since installation, the research team requested the cities provide the installation date for the treatments.



**Figure 11. Example of Crossing Distance Measurements, Going from North to South.**

### Data Collection

The research team defined a specific field study methodology and data collection protocol to collect the driver yielding data. The most important part of the field study was the use of a staged pedestrian protocol to collect driver yielding data. The staged pedestrian protocol ensures that oncoming drivers receive a consistent presentation of approaching pedestrians that meets the definition of Texas law. Under this protocol, a member of the research team acted as a pedestrian using the crosswalk at each study site, to stage the conditions under which driver yielding would be observed. Each staged pedestrian wore similar clothing (gray t-shirt, blue jeans, and gray tennis shoes; see Figure 12) and followed specific instructions in crossing the roadway. The staged pedestrian was accompanied by a second researcher, who observed and recorded the yielding data on pre-printed datasheets.



**Figure 12. Staged Pedestrian Crossing at a Crosswalk with Pedestrian Hybrid Beacon.**

Prior to the staged crossing maneuvers, researchers placed markers (either small contractor flags or cones) at the edge of the traveled way at a distance corresponding to the stopping sight distance (SSD) value in the American Association of State Highway and Transportation Officials (AASHTO) *Green Book (171)* for the posted speed limit at that site; the SSD values are 200 ft for 30 mph, 250 ft for 35 mph, 305 ft for 40 mph, and 360 for 45 mph. One marker was placed at the stopping sight distance in each direction approaching the crosswalk. After the study site had been prepared, the researchers followed the predetermined staged pedestrian protocol, which was defined as follows:

- The staged pedestrian approached the crosswalk as oncoming vehicles approached the SSD marker. Because each study site had a treatment that required the pedestrian to push a button to activate it, the staged pedestrian did so.
- The staged pedestrian reached the edge of the crosswalk in time to place one foot in the crosswalk (e.g., off the edge of the curb or curb ramp) within approximately 1 second of the approaching driver(s) reaching the SSD marker.
- The staged pedestrian waited to cross until approaching drivers yielded, or until all approaching drivers had traveled through the crosswalk.
- The observer recorded how many drivers yielded (and did not yield) that were in a position to yield for each crossing maneuver. Drivers were considered to be in position to yield if they were upstream of the SSD marker when the staged pedestrian was positioned at the edge of the crosswalk. Each such vehicle that did not yield was counted, as was each yielding vehicle. Of the vehicles in a position to yield, a vehicle was considered to be yielding if the driver slowed or stopped for the purpose of allowing the waiting pedestrian to cross. Any vehicles traveling in a platoon behind yielding vehicles were not counted because those drivers did not have the opportunity to make a decision on whether to yield; therefore, the maximum number of yielding vehicles possible for each crossing maneuver was equal to the number of travel lanes through which the crosswalk passes.

- Yielding was observed separately for each direction of vehicular travel because Texas law is written such that drivers must yield to pedestrians in or approaching their half of the roadway.
- The observer noted on the worksheet any unusual events or noteworthy comments for each crossing.
- Once the crosswalk was clear (i.e., the approaching vehicle had either stopped or passed through the crossing), the staged pedestrian crossed the street and waited on the sidewalk or roadside until all vehicles visible during that crossing traveled through the crosswalk. After all such vehicles had left the study site, the staged pedestrian prepared for the next crossing maneuver.

The protocol called for the completion of a minimum of 20 staged crossing maneuvers in each direction of travel during each observation period. Observation periods were chosen such that vehicle traffic was heavy enough to create frequent yielding situations, but not heavy enough for congestion to affect speeds. Data were always collected during daylight and in good weather, avoiding rain, wet pavement, dusk or dawn, or other conditions that affect a driver's ability to see and react to a waiting staged pedestrian. On rare occasions, the onset of rain, a nearby traffic collision, or nearby traffic enforcement delayed the completion of staged crossings; researchers waited until conditions were clear before resuming data collection. Researchers also avoided collecting data within or in close proximity to an active school zone.

### **Data Reduction**

After completing the data collection, researchers returned to the office and entered the crossing data and the site characteristics data from the field worksheets into an electronic database. The crossing data were reviewed for possible transcription errors and data entry errors and then formatted for analysis. The yielding rate was calculated as follows:

$$Yielding\ rate = \frac{\textit{number of yielding vehicles}}{\textit{number of yielding vehicles} + \textit{number of non-yielding vehicles}} \quad [1]$$

## **ANALYSIS**

### **Preliminary Analyses**

Preliminary analyses of the data are performed to determine if potential confounding between key variables are occurring or if there are potential outliers within a site (i.e., a unique staged pedestrian crossing is an outlier) or for a site (i.e., the conditions at the site result in concerns regarding all the crossing data). These analyses also permit the investigation on which variable format could produce better results, for example, should the variable be categorical (e.g., median type) or continuous (e.g., median width).

A potential anomaly identified within this data set is when there is a combination of (a) no vehicles yielding, and (b) few vehicles not yielding. The prime contributor to this situation is low volume at the site. Another reason could be that drivers are in platoons and are deciding to continue past the waiting pedestrian because they know there is a large gap available after the



platoon. To investigate if low volume and/or the characteristics of the vehicle platoons are affecting the driver yielding results would require a different data collection approach. The data collection approach selected for this study focused more on shorter data collection periods per site to permit collection at more sites. Therefore, the resources are not available to do a detailed investigation into how traffic volume is affecting the drivers' decision to yield or not yield. Three sites fit the criteria of having more than a quarter of the crossings occurring when a vehicle did not yield—one pedestrian hybrid beacon site (H-07-1) and two rectangular rapid-flashing beacon sites (W-02 and W-04). Confounding the consideration of whether these sites are truly outliers is that all three sites are in cities with few installations. Is the low driver yielding rates because of the city or because of low volume? Because of this concern, some of the evaluations will focus on cities with multiple installations (e.g., Austin for PHBs and Garland for RRFBs).

### **Modeling Approach**

When a driver approaches a crossing, the driver either yields and stops the vehicle or does not yield to the waiting staged pedestrian. This binary behavior (yield or no yield) can be modeled using logistic regression. Another significant advantage of using logistic regression is it permits consideration of individual crossing data rather than reducing all the data at a site to only one value. For the data set available within this study, that means over 2700 data points could be available (i.e., all the unique staged crossings recorded) rather than only 61 data points (i.e., the number of study sites). The larger sample size could result in finding significant relationships that would not be apparent with a smaller data set.

Using logistic regression to model the relationships assumes that the logit transformation of the outcome variable has a linear relationship with the predictor variables, which results in challenges in interpreting the regression coefficients. Odds ratios can be used to illustrate how to interpret the logistic regression results. As mentioned before, all regression coefficients are in a scale such that changes in driver yielding are mathematically linear. The interpretation of such coefficients is not on the yield rate changes but a change in the odds of drivers yielding (the odds are defined as the ratio of the number of yielding drivers to the number of non-yielding drivers).

The regression coefficients can be transformed and interpreted as odds ratios of different levels of the corresponding independent variable. In other words, the odds ratio is the expected change in the odds of drivers yielding per unit change of the independent variable. The first column of Table 38 shows two coefficients from a preliminary model on the data. The baseline treatment for this model is PHB (whose implicit coefficient is 0.0). The second column shows the same coefficients transformed into the corresponding odds ratios. Finally, the last two columns of Table 38 show a 95 percent confidence interval for the odds ratios.

**Table 38. Results from Preliminary Logistic Model Where the Baseline Treatment Is PHB.**

Variable	Coefficient	Odds Ratio*	95% Confidence Interval	
			2.50%	97.50%
<i>TreatmentRRFB</i>	-2.14842	0.1166	0.0664	0.1973
<i>TreatmentTCS</i>	1.75299	5.7718	3.2532	11.2251

\*Odds Ratio = Exp (Coefficient)

After accounting for other influential factors (i.e., the rest of the variables included in the model), the odds of drivers yielding at sites with RRFB are about 12 percent the odds of drivers yielding at sites with PHB. Similarly, the odds ratio indicates that the odds of drivers yielding at sites with TCS are about 5.8 times the odds of yielding at sites treated with PHB. Caution should be used when translating odds ratios into changes in yielding rates, as this relationship is not linear. For example, if the original rate of driver yielding is 50 percent, doubling the odds results in the driver yielding rate increasing to 66.67 percent, or an additional 16.67 percent of drivers. However, if the original rate of driver yielding is 90 percent instead, doubling the odds means that the rate increases to 94.74 percent, or just 4.74 percent more motorists yielding.

It is possible, therefore, to transform odds ratios to assess their corresponding impact on the yielding rates. However, such transformation is cumbersome. In order to avoid the distraction of transforming back and forth rates and odds ratios, this report will present simple averages of the driver yielding rates per site to illustrate the relationships found meaningful in the statistical analysis. The tables with the formal results will also be shown.

### **Comparison of Texas Average Results to Other Studies**

Table 39 provides the driver yielding values for nearside, farside, and the total crossings for each treatment. For each treatment, farside had higher average driver yielding as compared to nearside. Overall, traffic control signals in Texas have the highest driver yielding rates with an average of 98 percent for the seven sites. The average driver yielding for RRFB in Texas is 86 percent, while the average for PHBs was 89 percent.

The range of driver yielding at the PHB sites is 62 to 98 percent with an average of 89 percent. The average yielding rate for the PHBs in Texas is lower than the values identified elsewhere. A study conducted in Tucson found a range of 94 to 100 percent driver yielding for five sites with an average of 97 percent (1). The PHBs have been used in Tucson for both a longer time period and at more sites. The difference could indicate that familiarity with the device can improve compliance. The amount of driver education or enforcement efforts between the two cities is not known. Additional education and enforcement should help to improve driver yielding within Texas.

**Table 39. Average Driver Yielding by Treatment.**

Treatment	One-Way or Two-Way Traffic	Sites	Driver Yielding Near	Driver Yielding Far	Driver Yielding Total
PHB	One-Way	2	95%	NA	95%
	Two-Way	30	87%	90%	89%
	<b>Both</b>	<b>32</b>	<b>88%</b>	<b>NA</b>	<b>89%</b>
RRFB	One-Way	4	94%	NA	94%
	Two-Way	18	83%	86%	84%
	<b>Both</b>	<b>22</b>	<b>85%</b>	<b>NA</b>	<b>86%</b>
TCS	One-Way	1	98%	NA	98%
	Two-Way	6	97%	99%	98%
	<b>Both</b>	<b>7</b>	<b>97%</b>	<b>NA</b>	<b>98%</b>
Total		61	88%	NA	89%

NA = not available because one-way streets do not have any farside yielding.

While the driver yielding for PHBs is slightly lower than what has been recorded elsewhere, the average driver yielding for RRFBs within Texas is slightly higher than what has been recorded in other states. In an FHWA study (72), at approximately 30 days after installation, researchers reported a rate of 86 percent driver yielding for 19 sites in Florida, 65 percent driver yielding for two sites in Illinois, and 74 percent for one site in Washington, D.C., for an average of 82 percent driver yielding for all sites included in the study. Within this Texas study, the driver yielding at RRFB sites ranged from 32 to 96 percent with an average of 86 percent driver yielding for all sites in the study. A potential reason could be that all the RRFB sites included in this analysis had school crossing signs and were located near a school.

### Differences by Treatment Type

The initial step of the analysis was to determine if there was a significant difference in driver yielding between the three treatments studied. If differences exist, then how posted speed and crossing distance (or number of lanes) affect driver yielding may also differ by treatment type.

The results of the analysis are shown in Table 40, which can be compared with the average driver yielding values by treatment shown in Table 39. The preliminary modeling did show a significant difference between treatment types with traffic control signals having the highest driver yielding followed by pedestrian hybrid beacon. As expected, the RRFB had the lowest driver yielding values; however, the driver yielding rates are still very impressive for a device that shows the driver a yellow (i.e., warning) as compared to devices that show the driver a red (i.e., stop) indication.

**Table 40. All Data Model Results Focusing on Treatments.**

Call: glm(formula = cbind(TY, TN) ~ Treatment + M.PSL + M.O\_T + City,  
family = binomial, data = Data)

Deviance Residuals:

Min	1Q	Median	3Q	Max
-4.5114	0.2210	0.5720	0.7489	2.4675

Coefficients:

	Estimate	Std. Error	z value	Pr(> z )	
(Intercept)	1.95675	0.39862	4.909	9.16e-07	***
TreatmentRRFB	-2.14842	0.27689	-7.759	8.56e-15	***
TreatmentTCS	1.75299	0.31334	5.594	2.21e-08	***
M.PSL	0.03167	0.01139	2.781	0.00542	**
M.O_Ttwo	-0.76112	0.19024	-4.001	6.31e-05	***
CityDallas	0.88048	0.66101	1.332	0.18285	
CityFrisco	0.60912	0.36978	1.647	0.09951	.
CityGarland	1.94279	0.30542	6.361	2.00e-10	***
CityHouston	-1.20435	0.12732	-9.460	< 2e-16	***
CitySanAntonio	0.33227	0.35039	0.948	0.34299	
CityWaco	-0.56177	0.24552	-2.288	0.02213	*

---

Signif. codes: 0 '\*\*\*' 0.001 '\*\*' 0.01 '\*' 0.05 '.' 0.1 ' ' 1

(Dispersion parameter for binomial family taken to be 1)

Null deviance: 2735.6 on 2584 degrees of freedom  
Residual deviance: 2102.7 on 2574 degrees of freedom  
AIC: 2954

Number of Fisher Scoring iterations: 6

Odds Ratios

	2.5 %	Odds Ratio	97.5 %
TreatmentRRFB	0.06638559	0.1166689	0.1973078
TreatmentTCS	3.25316660	5.7718312	11.2251178
M.PSL	1.00946979	1.0321741	1.0555667
M.O_Ttwo	0.31715444	0.4671446	0.6699150
CityDallas	0.73830374	2.4120689	10.8305685
CityFrisco	0.90110834	1.8388060	3.8488349
CityGarland	3.88937975	6.9782041	12.9203258
CityHouston	0.23417795	0.2998875	0.3858863
CitySanAntonio	0.74247897	1.3941239	2.9800237
CityWaco	0.35988124	0.5701971	0.9466533

Categorical variables base value:

- Treatment = PHBs
- City = Austin
- M.O\_T (one-way or two-way operations on major roadway) = one-way

Continuous variables range:

- M.PSL (posted speed limit on major roadway) = 30 to 45 mph

## City or Density of Treatment

Table 41 shows the average driver yielding by treatment and city. The findings indicate the devices perform better in selected cities. For example, the RRFBs in Garland were associated with higher driver yielding values when compared to the Frisco site, although the cross section may be the reason for the difference. A similar trend was identified for PHBs, with Austin having higher yielding rates as compared to Houston or Waco. The results in Table 40 show that the following cities did have a significantly different driver yielding rate from Austin (base condition): Garland, Houston, and Waco. Potential reasons for the difference could include the following:

- Cities with extensive use of a device (e.g., Austin for PHB and Garland for RRFB) should have more drivers familiar with the treatment, which could improve understanding of yielding expectations.
- Cities with single use of a device could result in the device being an anomaly.
- Cities where the device is only used at a few locations may have the device at sites with extensive challenges (e.g., geometry that limits view of the crossing, higher speeds, etc.).
- Some cities may have had more comprehensive education and/or enforcement efforts in conjunction with implementing their treatments, which should improve compliance.
- Driver expectations for pedestrians in certain situations, such as near schools, could improve the driver compliance. All of the RRFB sites were near or adjacent to schools and had school crossing signs rather than pedestrian crossing signs.

**Table 41. Average Driver Yielding by Treatment and City.**

<b>Treatment</b>	<b>City</b>	<b>Sites</b>	<b>Driver Yielding Total</b>
PHB	Austin	25	92%
	Houston	4	73%
	San Antonio	1	94%
	Waco	2	85%
	<b>All</b>	<b>32</b>	<b>89%</b>
RRFB	Frisco	1	75%
	Garland	19	92%
	Waco	2	34%
	<b>All</b>	<b>22</b>	<b>86%</b>
TCS	Austin	1	100%
	Dallas	4	99%
	Houston	2	95%
	<b>All</b>	<b>7</b>	<b>98%</b>

## ANALYSIS BY TREATMENT

The next exploration efforts examined several roadway characteristics such as the following:

- Posted speed limit.
- Direction of traffic (i.e., one-way or two-way traffic).
- Crossing distance.

- Number of lanes.
- Median type.

These exploration efforts examined the variable effects on driver yielding by treatment type.

### **Traffic Control Signals**

The seven sites with TCS had driver yielding rates between 93 and 100 percent. The modeling considered several variables being researched in this study including posted speed limit, crossing distance, type of median treatment, city, one-way or two-way traffic, and number of lanes. None of these variables was found to be significant. The prime observation with regard to TCS in Texas at this time is that the overall driver yielding rate for the traffic control signal is higher than the other treatments studied (pedestrian hybrid beacon or rectangular rapid-flashing beacon).

### **Pedestrian Hybrid Beacon**

The modeling results for the pedestrian hybrid beacon are shown in Table 42. Using the results in Table 42 for the PHB, the crossing width, direction of traffic (one-way or two-way), and city variables were significant. Regarding the city variable, the driver yielding rates for the sites in Houston and Waco were lower than the driver yielding in most of the Austin sites or for the one site in San Antonio as shown in Figure 13 and Figure 14. The driver yielding for the Houston sites were less than the driver yielding recorded at any other PHB studied to date (1).

Wider crossing distances were associated with higher driver yielding results. When considering the Austin data (selected because Austin has the most PHB installations in Texas), on average the driver yielding ranged from 89 percent for a 45-ft crossing to 92 percent for a 68-ft crossing, with the site with 84-ft total crossing distance having a 94 percent driver yielding rate. The results clearly show that driver yielding remains high across a range of crossing distances. These results support the use of the PHB on roadways with multiple lanes or a wide crossing. The pedestrian hybrid beacons were located on roadways with two to six lanes with crossing distances between 20 and 92 ft.

Posted speed limit was found to be not significant. In other words, Texas drivers' behavior with respect to yielding to pedestrians crossing at a site with a pedestrian hybrid beacon is similar regardless of the posted speed limit. As shown in Table 35 and Figure 14, the posted speed limits represented in the data range from 30 mph to 45 mph.

To examine the potential effect of the presence of a median, another statistical evaluation was done where crossing distance was replaced with number of lanes and median type. Table 43 shows the results. The number of lanes and median type were significant. The presence of a flush or raised median resulted in higher total yielding as compared to when no median was present.

**Table 42. PHB Total Driver Yielding Model Results Using Total Crossing Distance.**

```

Call: glm(formula = cbind(TY, TN) ~ M.PSL + M.O_T + Total_CD + City,
         family = binomial, data = subset(Data, Treatment == "PHB"))

Deviance Residuals:
    Min       1Q   Median       3Q      Max
-4.4636  0.3063  0.6241  0.7643  1.5374

Coefficients:
                Estimate Std. Error z value Pr(>|z|)
(Intercept)    2.565052   0.501472   5.115 3.14e-07 ***
M.PSL          -0.008225   0.016892  -0.487  0.62632
M.O_Ttwo       -0.673529   0.359454  -1.874  0.06096 .
Total_CD        0.012374   0.004635   2.670  0.00759 **
CityHouston    -1.176376   0.130624  -9.006 < 2e-16 ***
CitySanAntonio  0.092932   0.364272   0.255  0.79863
CityWaco       -0.575165   0.245933  -2.339  0.01935 *
---
Signif. codes:  0 '***' 0.001 '**' 0.01 '*' 0.05 '.' 0.1 ' ' 1

(Dispersion parameter for binomial family taken to be 1)

Null deviance: 1309.2 on 1463 degrees of freedom
Residual deviance: 1209.6 on 1457 degrees of freedom
AIC: 1749.7

Number of Fisher Scoring iterations: 5

Odds Ratios:
                2.5 % Odds Ratio   97.5 %
M.PSL          0.9598650 0.9918090 1.0256235
Total_CD       1.0032832 1.0124507 1.0217011
M.O_Ttwo       0.2350977 0.5099059 0.9777214
CityHouston    0.2393522 0.3083943 0.3995935
CitySanAntonio 0.5659813 1.0973867 2.3986417
CityWaco       0.3547707 0.5626123 0.9347265

Categorical variables base value:
  • City = Austin
  • M.O_T (one-way or two-way operations on major roadway) = one-way
Continuous variables range:
  • M.PSL (posted speed limit on major roadway) = 30 to 45 mph
  • Total_CD (total crossing distance) = 20 to 92 ft

```

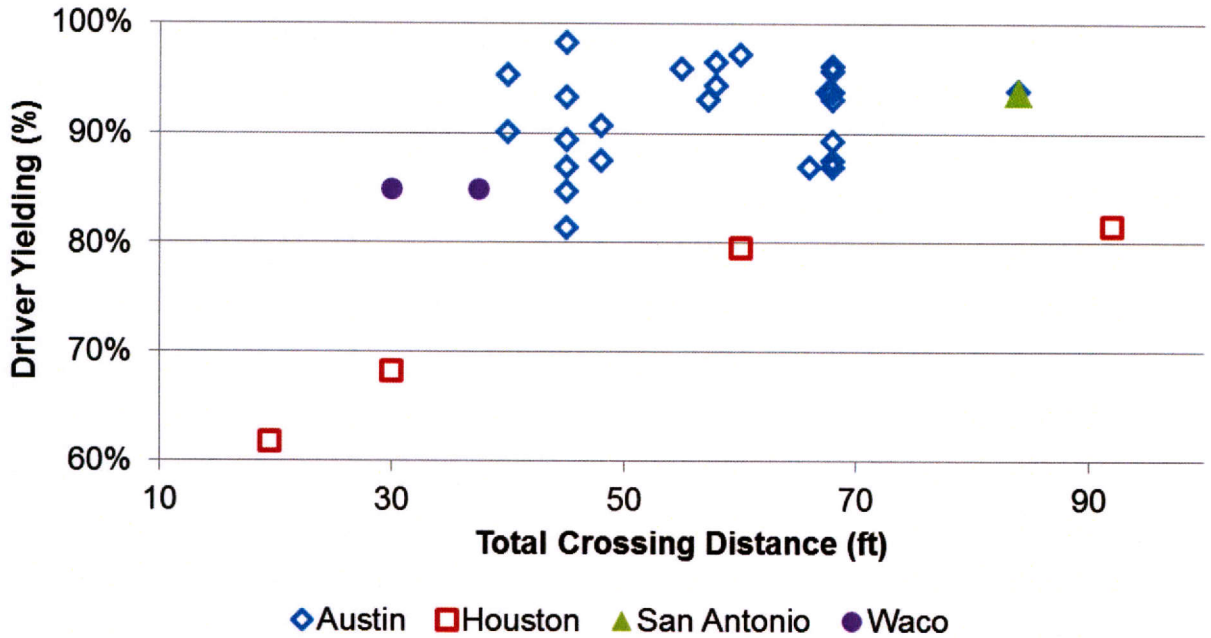


Figure 13. Pedestrian Hybrid Beacon: Driver Yielding by Total Crossing Distance.

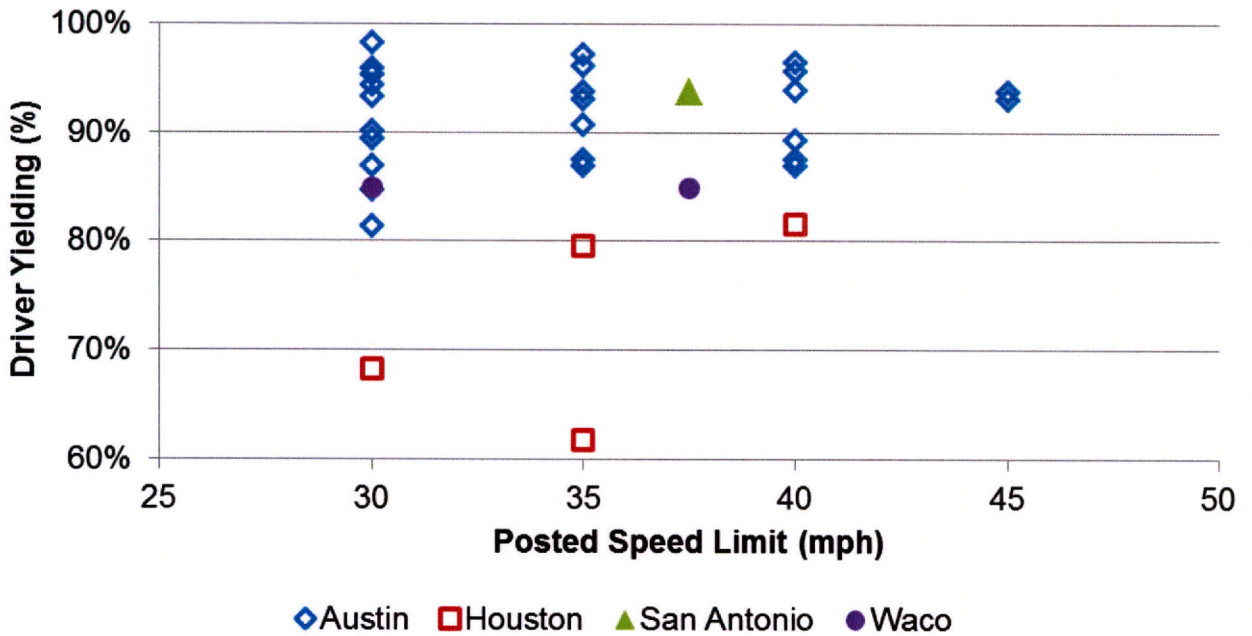


Figure 14. Pedestrian Hybrid Beacon: Driver Yielding by Posted Speed Limit.



**Table 43. PHB Total Driver Yielding Model Results Using Number of Lanes and Median Type.**

```

Call: glm(formula = cbind(TY, TN) ~ M.PSL + M.O_T + N.Lanes.Tot + City +
  Median, family = binomial, data = subset(Data, Treatment ==
  "PHB"))

Deviance Residuals:
  Min       1Q   Median       3Q      Max
-4.4666  0.3099  0.6193  0.7404  1.5713

Coefficients:
              Estimate Std. Error z value Pr(>|z|)
(Intercept)   2.910826   0.557748   5.219 1.8e-07 ***
M.PSL         -0.013943   0.017190  -0.811  0.4173
M.O_Ttwo     -0.787771   0.365411  -2.156  0.0311 *
N.Lanes.Tot   0.129933   0.061039   2.129  0.0333 *
CityHouston  -1.190930   0.139147  -8.559 < 2e-16 ***
CitySanAntonio 0.004137   0.389443   0.011  0.9915
CityWaco     -0.519946   0.250051  -2.079  0.0376 *
Medianflush   0.331511   0.160288   2.068  0.0386 *
MedianRaised  0.322534   0.166793   1.934  0.0531 .
---
Signif. codes:  0 '***' 0.001 '**' 0.01 '*' 0.05 '.' 0.1 ' ' 1

(Dispersion parameter for binomial family taken to be 1)

Null deviance: 1309.2 on 1463 degrees of freedom
Residual deviance: 1207.2 on 1455 degrees of freedom
AIC: 1751.3

Number of Fisher Scoring iterations: 5
Categorical variables base value:
  • City = Austin
  • M.O_T (one-way or two-way operations on major roadway) = one-way
  • Median (median type on major roadway) = none
Continuous variables range:
  • M.PSL (posted speed limit on major roadway) = 30 to 45 mph
  • N.Lanes.Tot (number of lanes on major roadway) = 2, 4, 5, or 6 lanes

```

**Rectangular Rapid-Flashing Beacon**

The modeling results for the RRFB are shown in Table 44. For RRFB, posted speed limit, total crossing distance, one-way versus two-way traffic, and city were all significant. Median type was considered in an earlier model but was found to be not significant. When cross section (combination of number of lanes and median type) was used in the model rather than crossing distance, it was also found to be not significant.

**Table 44. RRFB Total Driver Yielding Model Results.**

```

Call:
glm(formula = cbind(TY, TN) ~ M.PSL + Total_CD + M.O_T + City,
     family = binomial, data = subset(Data, Treatment == "RRFB"))

Deviance Residuals:
    Min       1Q   Median       3Q      Max
-4.2373  0.3457  0.5191  0.6914  2.5058

Coefficients:
            Estimate Std. Error z value Pr(>|z|)
(Intercept) -2.47815    1.51421  -1.637  0.10171
M.PSL        0.12585    0.03872   3.250  0.00115 **
Total_CD     -0.01223    0.00617  -1.982  0.04751 *
M.O_Ttwo     -0.64290    0.30922  -2.079  0.03761 *
CityGarland  1.39867    0.34448   4.060  4.9e-05 ***
CityWaco     -0.52276    0.61489  -0.850  0.39523
---
Signif. codes:  0 '***' 0.001 '**' 0.01 '*' 0.05 '.' 0.1 ' ' 1

(Dispersion parameter for binomial family taken to be 1)

Null deviance: 1199.2 on 873 degrees of freedom
Residual deviance: 807.5 on 868 degrees of freedom
AIC: 1100.1

Number of Fisher Scoring iterations: 5
Odds Ratios:
            2.5 % Odds Ratio   97.5 %
M.PSL      1.0512835  1.1341175  1.2237446
Total_CD   0.9757383  0.9878481  0.9996449
M.O_Ttwo   0.2852636  0.5257665  0.9622727
CityGarland 2.0626745  4.0497903  7.9703682
CityWaco   0.1757795  0.5928814  1.9613157
Categorical variables base value:
  • City = Frisco
  • M.O_T (one-way or two-way operations on major roadway) = one-way
Continuous variables range:
  • M.PSL (posted speed limit on major roadway) = 30 to 45 mph
  • N.Lanes.Tot (number of lanes on major roadway) = 2, 4, 5, or 6 lanes

```

The modeling results show the following:

- Higher compliance at higher speed limits.
- Higher compliance for one-way roads as compared to two-way roads.
- Lower compliance at longer crossing distances (which is opposite of the finding for PHB).
- Higher compliance in Garland.

RRFB sites with higher posted speed limits were associated with higher driver yielding values (see Figure 15). When reviewing Figure 15, the two Waco sites with 30 mph posted speed limit have very low driver yielding (below 40 percent). These sites had low volumes during data collection, which resulted in several crossings having no vehicles yielding. Even when these two sites are removed from the model, the trend of higher driver yielding for higher speed was still present and statistically significant. A closer review of the data reveal that while driver yielding is higher for the 40 mph sites as compared to the 35 mph sites, overall the difference is very small (only 1 percentage point between the two averages; see Table 45). So while there may be a statistically significant increase in driver yielding by speed limit, the difference is not of practical significance. A theory is that perhaps drivers on the higher posted speed roads recognize the difficulties pedestrians have in crossing the roadway and are willing to stop and provide the gap the pedestrian needs.

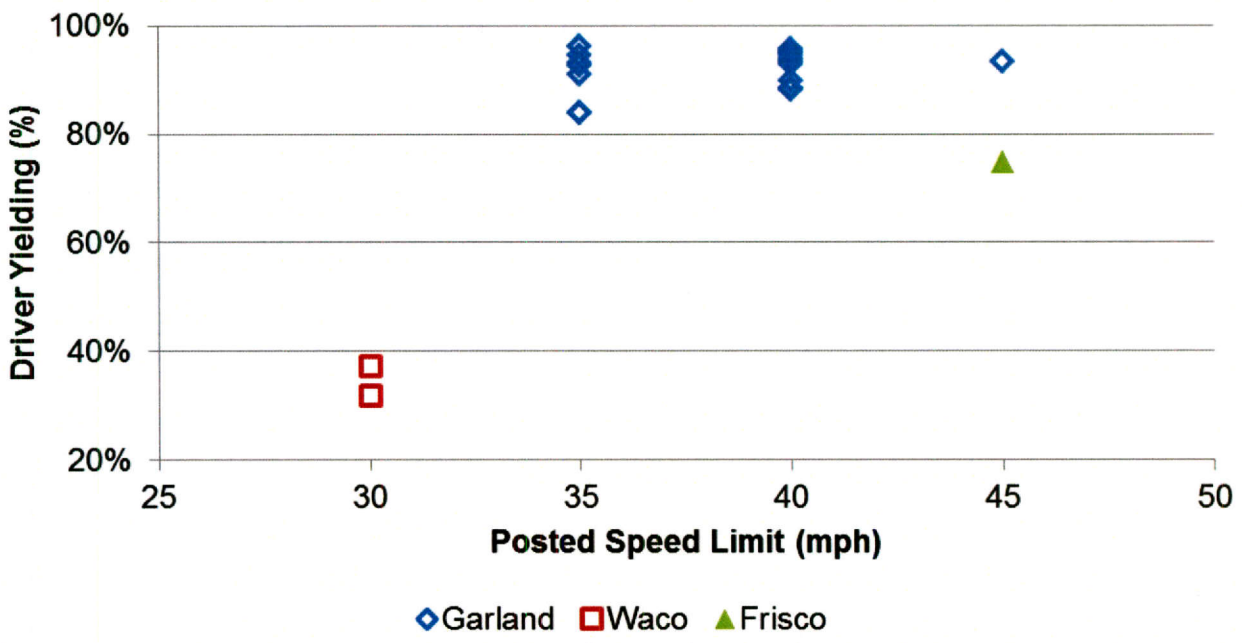


Figure 15. Rectangular Rapid-Flashing Beacon: Driver Yielding by Posted Speed Limit.

Table 45. Average Driver Yielding by Posted Speed Limit for RRFB Sites.

Posted Speed Limit (mph)	Average Driver Yielding	Number of Sites
30	34%	2
35	91%	7
40	92%	11
45	84%	2
<b>Grand Total</b>	<b>86%</b>	<b>22</b>

Another not obvious relationship is why drivers on a roadway with only one-way traffic stop more frequently for waiting pedestrians as compared to drivers on roadways with two-way traffic. Table 46 lists the average driver yielding by one-way and two-way traffic. All the one-

way sites had a crossing distance of 44 ft, while the two-way sites had crossing distances between 38 and 120 ft. So an interpretation of the one-way versus two-way traffic finding may be that it is heavily influenced by the crossing distance relationship with driver yielding.

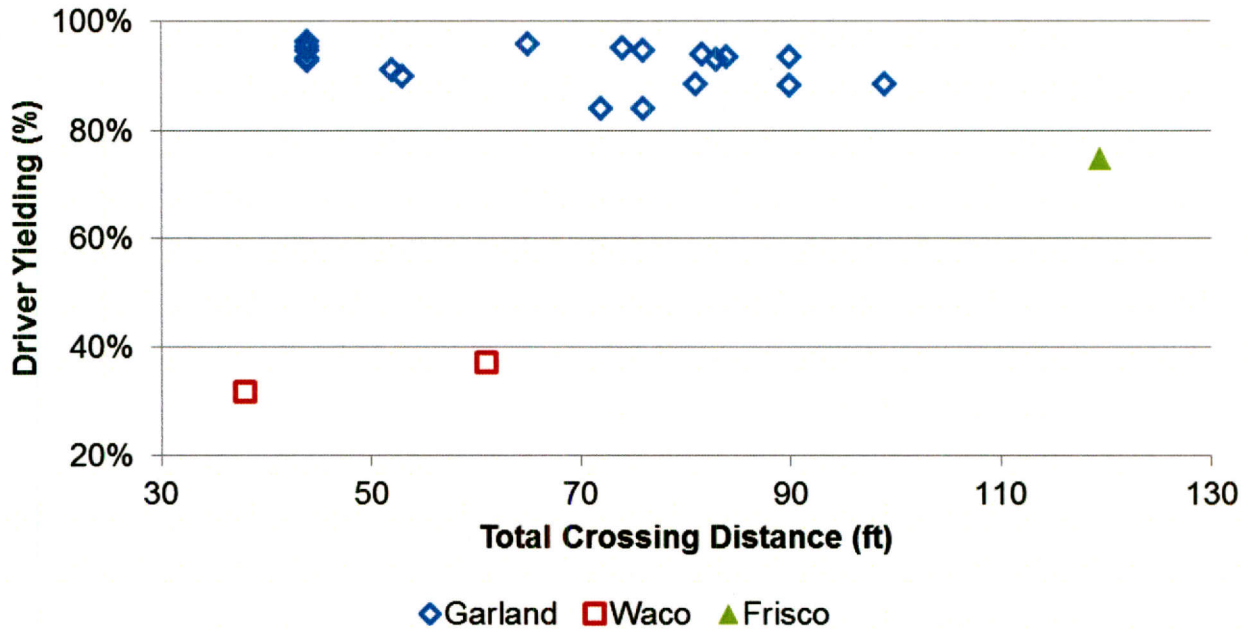
**Table 46. Average Driver Yielding by One-Way or Two-Way Traffic for RRFB Sites.**

<b>One-Way or Two-Way Traffic</b>	<b>Average Driver Yielding</b>	<b>Number of Sites</b>	<b>Crossing Distance (ft)</b>
One-Way Traffic	94%	4	44
Two-Way Traffic	84%	18	38 to 120
<b>Grand Total</b>	<b>86%</b>	<b>22</b>	<b>38 to 120</b>

The data revealed a trend of lower driver yielding rates for wider crossing distances (see Figure 16). Perhaps drivers believe that the greater distance between their vehicles and the pedestrian presents the opportunity to not stop for the waiting pedestrian. For example, a driver on a six-lane road has multiple lanes in which to adjust position, perhaps feeling that leaving a full traffic lane between the car and the crossing pedestrian is sufficient. In addition, the legal requirements for when drivers shall yield to a pedestrian may be a factor. The Texas Transportation Code, Section 552.003 (Pedestrian Right-of-Way at Crosswalk) (172) states: 552.003. PEDESTRIAN RIGHT-OF-WAY AT CROSSWALK.

- (a) The operator of a vehicle shall yield the right-of-way to a pedestrian crossing a roadway in a crosswalk if:
  - (1) no traffic control signal is in place or in operation; and
  - (2) the pedestrian is:
    - (A) on the half of the roadway in which the vehicle is traveling; or
    - (B) approaching so closely from the opposite half of the roadway as to be in danger.
- (b) Notwithstanding Subsection (a), a pedestrian may not suddenly leave a curb or other place of safety and proceed into a crosswalk in the path of a vehicle so close that it is impossible for the vehicle operator to yield.
- (c) The operator of a vehicle approaching from the rear of a vehicle that is stopped at a crosswalk to permit a pedestrian to cross a roadway may not pass the stopped vehicle.

The model shown in Table 44 uses Frisco as the base city and provides coefficients for the two other cities. The driver yielding rate for Waco is lower as compared to Frisco (not statistically significant), while driver yielding is higher for Garland (statistically significant). The greater number of the devices in Garland may be contributing to drivers being more familiar with the treatment, which could be contributing to the better driver yielding behavior.



**Figure 16. Rectangular Rapid-Flashing Beacon: Driver Yielding by Total Crossing Distance.**

### ANALYSIS BY NEARSIDE AND FAR SIDE

The number of drivers yielding to pedestrians may vary depending upon the starting position of the pedestrian and the direction of travel for the vehicle. For the nearside portion of the crossing, i.e., the direction of travel nearest to or initially crossed by the pedestrian (see Figure 10 or Figure 11 for examples), drivers may be more likely to yield because of the closeness to the pedestrian. On the other hand, drivers may believe that since the pedestrians are so near to the sidewalk, they can continue to wait there until the driver has passed the crosswalk. For the farside, the driver has a longer time to observe the pedestrian and to see the pedestrian already in the roadway, so farside may have higher driver yielding results. Along with whether there is a difference in farside and nearside driver yielding results is the question of whether the roadway characteristics affect the yielding results differently for the farside condition and the nearside condition. The collected data were subdivided into farside and nearside driver yielding results so these theories could be tested.

### Pedestrian Hybrid Beacon

The results for the pedestrian hybrid beacon are shown in Table 47 for nearside yielding and Table 48 for farside yielding. Similar to total yielding, city and one-way versus two-way operations (when relevant, one-way streets do not have farside data) were statistically significant. Interesting is that number of lanes and median type are significant for farside yielding (as they were for total yielding; see Table 43), but not for nearside yielding. It appears that a driver making the decision on whether to stop for a pedestrian waiting at the edge of the roadway is not influenced by the number of lanes or the type of median. The results of the farside yielding

demonstrated an added value of separating the two directions of traffic. More drivers yielded to pedestrians when a raised median or a TWLTL was present as compared to when no median was present (see Table 49).

**Table 47. PHB Nearside Yielding Model Results Using Number of Lanes and Median Type.**

```

Call:glm(formula = cbind(NSY, NSN) ~ M.PSL + M.O_T + N.Lanes.Tot +
  City + Median, family = binomial, data = subset(Data, Treatment ==
  "PHB"))

Deviance Residuals:
    Min       1Q   Median       3Q      Max
-3.3599  0.0000  0.4985  0.6453  1.2014

Coefficients:
              Estimate Std. Error z value Pr(>|z|)
(Intercept)   2.975913   0.676099   4.402 1.07e-05 ***
M.PSL         -0.008322   0.022959  -0.362  0.7170
M.O_Ttwo      -0.846388   0.383755  -2.206  0.0274 *
N.Lanes.Tot    0.071505   0.081966   0.872  0.3830
CityHouston   -1.050642   0.188555  -5.572 2.52e-08 ***
CitySanAntonio -0.479210   0.450104  -1.065  0.2870
CityWaco      -0.715049   0.314770  -2.272  0.0231 *
Medianflush   0.142287   0.215710   0.660  0.5095
MedianRaised  0.127080   0.224962   0.565  0.5721
---
Signif. codes:  0 '***' 0.001 '**' 0.01 '*' 0.05 '.' 0.1 ' ' 1

(Dispersion parameter for binomial family taken to be 1)

Null deviance: 945.62 on 1299 degrees of freedom
Residual deviance: 899.44 on 1291 degrees of freedom
AIC: 1182.4

Number of Fisher Scoring iterations: 5

```

---

Categorical variables base value:

- City = Austin
- M.O\_T (one-way or two-way operations on major roadway) = one-way
- Median (median type on major roadway) = none

Continuous variables range:

- M.PSL (posted speed limit on major roadway) = 30 to 45 mph
- N.Lanes.Tot (number of lanes on major roadway) = 2, 4, 5, or 6 lanes

**Table 48. PHB Farside Yielding Model Results Using Number of Lanes and Median Type.**

```

Call: glm(formula = cbind(FSY, FSN) ~ M.PSL + M.O_T + N.Lanes.Tot +
      City + Median, family = binomial, data = subset(Data, Treatment ==
      "PHB"))

Deviance Residuals:
      Min       1Q   Median       3Q      Max
-3.3070  0.0000  0.4085  0.5183  1.1095

Coefficients: (1 not defined because of singularities)
              Estimate Std. Error z value Pr(>|z|)
(Intercept)  2.03666    0.75218   2.708  0.00678 **
M.PSL        -0.01835    0.02626  -0.699  0.48457
M.O_Ttwo           NA           NA       NA       NA
N.Lanes.Tot   0.20542    0.09397   2.186  0.02882 *
CityHouston  -1.32708    0.21079  -6.296 3.06e-10 ***
CitySanAntonio 1.28076    1.04437   1.226  0.22007
CityWaco     -0.22318    0.42025  -0.531  0.59537
Medianflush  0.54496    0.24127   2.259  0.02390 *
MedianRaised 0.54254    0.24982   2.172  0.02987 *
---
Signif. codes:  0 '***' 0.001 '**' 0.01 '*' 0.05 '.' 0.1 ' ' 1

(Dispersion parameter for binomial family taken to be 1)

Null deviance: 743.10  on 1140  degrees of freedom
Residual deviance: 669.99  on 1133  degrees of freedom
AIC: 855.91

Number of Fisher Scoring iterations: 6
Categorical variables base value:
  • City = Austin
  • M.O_T (one-way or two-way operations on major roadway) = one-way
  • Median (median type on major roadway) = none
Continuous variables range:
  • M.PSL (posted speed limit on major roadway) = 30 to 45 mph
  • N.Lanes.Tot (number of lanes on major roadway) = 2, 4, 5, or 6 lanes

```

**Table 49. PHB Average Driver Yielding by Median Treatment and One-Way/Two-Way Traffic.**

One-Way or Two-Way Traffic	Median Type	Number of Sites	Average Total Driver Yielding	Average Farside Driver Yielding	Average Nearside Driver Yielding
one	None	2	95%	NA	95%
two	None	10	86%	87%	86%
two	Raised	10	88%	92%	90%
two	TWLTL	10	88%	92%	90%

NA = Not applicable.

The result for number of lanes is interesting (see Table 50). It is typically easier for a pedestrian to cross fewer lanes because of the shorter crossing distance. The results for the Texas pedestrian hybrid beacons show lower driver yielding compliance for the two-lane sites; however, this is an example of why crossing distance may be a more informative variable than number of lanes. All of the Austin two-lane sites had 45-ft crossing distances, which is wider than some of the four-lane sites (range from 40 ft to 68 ft total crossing distances). Each of the Austin two-lane sites included in this study had bike lane and a two-way, left-turn lane.

**Table 50. PHB Average Driver Yielding by One-Way/Two-Way Traffic and Number of Lanes.**

<b>One-Way or Two-Way Traffic</b>	<b>Number of Lanes</b>	<b>Number of Sites</b>	<b>Average Total Driver Yielding</b>	<b>Average Farside Driver Yielding</b>	<b>Average Nearside Driver Yielding</b>
one	4	2	95%	NA	95%
two	2	10	83%	83%	83%
two	4	17	90%	93%	92%
two	5	1	89%	100%	94%
two	6	2	85%	92%	88%

NA = Not applicable.

### **Rectangular Rapid-Flashing Beacon**

For the investigation of farside and nearside yielding with RRFBs, only the data for Garland were considered, as most of the RRFB data were from Garland (19 of the 22 sites) and it permitted the consideration of whether the beacons were located roadside only or both roadside and overhead on a mast arm. The results are shown in Table 51 for nearside driver yielding and Table 52 for farside driver yielding.

Results were interesting in that very few of the variables were statistically significant to driver yielding. For nearside driver yielding, only whether traffic was one-way or two-way was significant, while for farside driver yielding none of the variables was significant using a 0.05 p-value. The crossing distance specific to the farside or nearside crossing was not significant. Whether the beacons were located on the mast arm or only on the roadside was also not significant for nearside or farside yielding.



**Table 51. RRFB Nearside Driver Yielding Model Results Using Crossing Distance and Location of Beacons for Garland Sites.**

```
Call: glm(formula = cbind(NSY, NSN) ~ M.PSL + M.O_T + Near_CD + T.Location,
family = binomial, data = subset(Data, Treatment == "RRFB" &
City == "Garland"))
```

Deviance Residuals:

Min	1Q	Median	3Q	Max
-3.6404	0.0000	0.4585	0.5988	0.8690

Coefficients:

	Estimate	Std. Error	z value	Pr(> z )
(Intercept)	1.09884	3.02500	0.363	0.716
M.PSL	0.06323	0.07996	0.791	0.429
M.O_Ttwo	-0.84867	0.37061	-2.290	0.022 *
Near_CD	-0.01192	0.01535	-0.776	0.437
T.LocationRoadside	-0.10297	0.45895	-0.224	0.822

---

Signif. codes: 0 '\*\*\*' 0.001 '\*\*' 0.01 '\*' 0.05 '.' 0.1 ' ' 1

(Dispersion parameter for binomial family taken to be 1)

Null deviance: 434.62 on 613 degrees of freedom  
Residual deviance: 426.71 on 609 degrees of freedom  
AIC: 532.96

Number of Fisher Scoring iterations: 5

Categorical variables base value:

- M.O\_T (one-way or two-way operations on major roadway) = one-way
- T.Location (location of RRFBs, either roadside only or overhead and roadside) = overhead and roadside

Continuous variables range:

- M.PSL (posted speed limit on major roadway) = 35 to 45 mph
- Far\_CD (farside crossing distance) = 22 to 56 ft

**Table 52. RRFB Farside Driver Yielding Model Results Using Crossing Distance and Location of Beacons for Garland Sites.**

```

glm(formula = cbind(FSY, FSN) ~ M.PSL + M.O_T + Far_CD + T.Location,
     family = binomial, data = subset(Data, Treatment == "RRFB" &
     City == "Garland"))

Deviance Residuals:
    Min       1Q   Median       3Q      Max
-4.3791  0.0000  0.3823  0.5691  0.8448

Coefficients: (1 not defined because of singularities)
              Estimate Std. Error z value Pr(>|z|)
(Intercept)   -4.085851   3.215944  -1.270  0.2039
M.PSL          0.160212   0.084130   1.904  0.0569
M.O_Ttwo      NA          NA          NA    NA
Far_CD         0.004287   0.016802   0.255  0.7986
T.LocationRoadside -0.038391  0.486793  -0.079  0.9371
---
Signif. codes:  0 '***' 0.001 '**' 0.01 '*' 0.05 '.' 0.1 ' ' 1

(Dispersion parameter for binomial family taken to be 1)

Null deviance: 303.75  on 440  degrees of freedom
Residual deviance: 293.82  on 437  degrees of freedom
AIC: 358.63

Number of Fisher Scoring iterations: 5

```

Categorical variables base value:

- M.O\_T (one-way or two-way operations on major roadway) = one-way
- T.Location (location of RRFBs, either roadside only or overhead and roadside) = overhead and roadside

Continuous variables range:

- M.PSL (posted speed limit on major roadway) = 35 to 45 mph
- Far\_CD (farside crossing distance) = 22 to 56 ft

**ANALYSIS BY TIME SINCE INSTALLATION**

As drivers become more familiar with these devices over time, they may have a better understanding of expectations or requirements and driver yielding may improve. The date of installations for the Austin PHB sites and the Garland RRFB sites were obtained. Because of the limited variability in posted speed limit and crossing distance for the two-lane PHB sites (the 3 sites all had 45-ft crossing distance and 30-mph posted speed limit), the analysis was conducted on those sites with four or more lanes. Table 53 shows the model results for PHBs. The results indicated a learning curve at PHB sites. The odds ratios are shown in Table 53. The odds of driver yielding increase by a factor of 1.0008 each day since installation. When translating this effect into rates, the effect is more pronounced at lower rates and it flattens as the yield increases (see Table 54). If the initial yielding rate was 85 percent, then the model would predict that the yielding would be 88.5 percent after 1 year and 91.3 percent after 2 years. If the initial driver

yielding rate was 95 percent, then the estimated driver yielding rate would be 96 percent after 1 year and 97 percent after 2 years. The number of days since installation for these estimates is within the range of study data (194 to 1044 days, a range that goes from less than a year up to almost 3 years). These predictions may be unique to the conditions in Austin in that Austin was the first city in the state to install the device and many more devices have been installed in the past few years. This finding supports the theory that multiple installations of a unique or innovative device can help improve compliance throughout a network. A word of caution should be added in that an excessive use of any traffic control device could lead to disrespect; the point of when too many of a particular traffic control device has been installed is an area of needed research.

The researchers attempted to do a similar evaluation using the data for Garland; however, statistical issues were present that limited the findings. All sites in Garland had been installed for less than a year when studied and had a potential multicollinearity effect because there is a correlation between treatment location (overhead or roadside only) and number of days since installation. Most of the sites with overhead installation (75 percent of the data) had between 59 and 62 days since installation, whereas 75 percent of the data from sites with roadside-only installation had between 118 and 119 days since installation. The direction of the effect of number of days was the same as in Austin PHBs, but it is statistically insignificant (see Table 55).

**Table 53. PHB Total Driver Yielding Model Results Using Time since Installation for Austin Sites with Four or More Lanes.**

```

Call: glm(formula = cbind(TY, TN) ~ M.PSL + M.O_T + Total_CD +
Days_Inst.Coll,
  family = binomial(link = "logit"), data = subset(Data, City ==
  "Austin" & Treatment == "PHB" & N.Lanes.Tot > 2))

Deviance Residuals:
    Min       1Q   Median       3Q      Max
-4.4212  0.4044  0.6346  0.7772  1.0859

Coefficients:
              Estimate Std. Error z value Pr(>|z|)
(Intercept)  2.0469842  0.7220155   2.835  0.00458 **
M.PSL        0.0154770  0.0238059   0.650  0.51561
M.O_Ttwo     -0.7557134  0.3783300  -1.997  0.04577 *
Total_CD     0.0012060  0.0090997   0.133  0.89456
Days_Inst.Coll 0.0008414  0.0003748   2.245  0.02479 *
---
Signif. codes:  0 '***' 0.001 '**' 0.01 '*' 0.05 '.' 0.1 ' ' 1

(Dispersion parameter for binomial family taken to be 1)

Null deviance: 737.87  on 892  degrees of freedom
Residual deviance: 728.59  on 888  degrees of freedom
AIC: 1046.3

Number of Fisher Scoring iterations: 5

Categorical variables base value:
  • M.O_T (one-way or two-way operations on major roadway) = one-way
Continuous variables range:
  • M.PSL (posted speed limit on major roadway) = 30 to 45 mph
  • Total_CD (total crossing distance) = 40 to 84 ft
  • Days_Inst.Coll (number of days since installation) = 77 to 1044 days

Odds Ratio:
              2.5 % Odds Ratio   97.5 %
M.PSL        0.9693767  1.0155974  1.0643274
M.O_Ttwo     0.2100653  0.4696754  0.9407136
Total_CD     0.9835838  1.0012068  1.0193407
Days_Inst.Coll 1.0001221  1.0008417  1.0015967

```

**Table 54. Predicted Driver Yielding Rate a Year or Two Years After Installation.**

Initial Yielding Rate (Hypothetical)	Yielding Rate after a Year	Yielding Rate after 2 Years
80.0%	84.5%	88.1%
85.0%	88.5%	91.3%
90.0%	92.4%	94.3%
95.0%	96.2%	97.2%

**Table 55. RRFB Driver Yielding Model Results Using Time since Installation for Garland Sites with Four or More Lanes.**

```

Call:
glm(formula = cbind(TY, TN) ~ M.PSL + M.O_T + Total_CD + Days_Inst.Coll +
  T.Location, family = binomial(link = "logit"), data = subset(Data,
  City == "Garland" & Treatment == "RRFB"))

Deviance Residuals:
    Min       1Q   Median       3Q      Max
-4.2641  0.3646  0.5297  0.6914  1.1845

Coefficients:
                Estimate Std. Error z value Pr(>|z|)
(Intercept)      2.5468971  2.4631956   1.034  0.3011
M.PSL             0.0396858  0.0615779   0.644  0.5193
M.O_Ttwo         -0.2858457  0.3655250  -0.782  0.4342
Total_CD         -0.0274783  0.0118848  -2.312  0.0208 *
Days_Inst.Coll   0.0009778  0.0030635   0.319  0.7496
T.LocationRoadside 0.7463465  0.5321038   1.403  0.1607
---
Signif. codes:  0 '***' 0.001 '**' 0.01 '*' 0.05 '.' 0.1 ' ' 1

(Dispersion parameter for binomial family taken to be 1)

Null deviance: 596.51 on 740 degrees of freedom
Residual deviance: 572.52 on 735 degrees of freedom
AIC: 772.22

Number of Fisher Scoring iterations: 5

```

---

```

Categorical variables base value:
  • M.O_T (one-way or two-way operations on major roadway) = one-way
  • T.Location (location of RRFBs, either roadside only or overhead and
    roadside) = overhead and roadside
Continuous variables range:
  • M.PSL (posted speed limit on major roadway) = 30 to 45 mph
  • Total_CD (total crossing distance) = 44 to 90 ft
  • Days_Inst.Coll (number of days since installation) = 59 to 119 days

```

**SUMMARY**

This research effort explored the factors associated with higher driver yielding at pedestrian crossings with traffic control signals, pedestrian hybrid beacons, and rectangular rapid-flashing beacon treatments in Texas. The percentages of drivers yielding to a staged pedestrian were collected at 7 TCS sites, 22 RRFB sites, and 32 PHB sites. Overall, traffic control signals in Texas have the highest driver yielding rates with an average of 98 percent. The average driver yielding rate for RRFB in Texas is 86 percent, while the average for PHBs is 89 percent. The

Texas RRFB results were slightly higher than other studies, perhaps because all the RRFB sites included in this analysis had school crossing signs and were located near a school. The number of devices within a city may have an impact on driver yielding. Those cities with a greater number of a particular device (i.e., Austin for the PHB and Garland for the RRFB) had higher driver yielding rates as compared to cities where the device was only used at a few crossings. Comparing the number of days since installation revealed statistically significant higher driver yielding rates for those devices that had been installed longer. For PHB, the results support the use of the PHB on roadways with multiple lanes or a wide crossing. For RRFB, lower compliance was observed for the longer crossing distances, which indicates that there is a crossing distance width where a device other than the RRFB should be considered.

## CHAPTER 8

# PEDESTRIAN AND DRIVER BEHAVIOR BEFORE AND AFTER INSTALLATION OF PEDESTRIAN TREATMENTS

### BACKGROUND

Similar to the driver yielding study described in Chapter 7, the rectangular rapid-flashing beacon and pedestrian hybrid beacon have shown great potential in improving driver yielding rates across the United States, and their positive effects at locations in Texas are worthy of further study. Of particular issue is how much yielding rates change at a crosswalk after these treatments are installed.

### OBJECTIVE

This research effort identified the changes in driver and pedestrian behaviors resulting from installing PHB or RRFB treatments at crosswalks in Texas. The objective of this study was to determine what effects these treatments had on driver yielding and selected pedestrian behaviors at previously untreated crosswalks.

### FIELD STUDY METHODOLOGY

The data needed to conduct the analysis for this field study consisted of two primary components:

- Video of pedestrian and driver behavior at sites with and without pedestrian treatments.
- Site characteristics at each study site.

The research team defined a specific field study methodology and data collection protocol to collect the field study data. A key part of the field study was the use of a staged pedestrian protocol to collect driver yielding data to provide consistent crossing conditions at all sites, but non-staged pedestrian crossings at the crosswalk and outside of the crosswalk (i.e., “jaywalking” pedestrian crossings) were also documented to provide data on selected pedestrian behavior characteristics. The use of a staged pedestrian protocol ensures that oncoming drivers receive a consistent presentation of approaching pedestrians that meets the definition of Texas law. The staged pedestrian protocol used in this field study was identical to that used for the cross-sectional driver yielding study, in that members of the research team were to complete at least 20 crossings in each direction at each study site, using a consistent presentation of the pedestrian’s position at the edge of the crosswalk while an observer documented whether approaching drivers yielded. Readers are referred to the discussion of the field study methodology for the driver yielding study in Chapter 7 to view the details of the staged pedestrian protocol.

While at the study site, researchers also documented the characteristics of each site, using a pre-printed datasheet. The observer’s datasheet for this study also provided space to document both staged and non-staged pedestrian crossings at the site. For non-staged crossings, the worksheet

requires the observer to note whether the pedestrian activated the treatment (if present) prior to crossing. While staged pedestrians always activated installed treatments, this allowed researchers to determine to what extent non-staged pedestrians were using and obeying the new treatment after its installation.

The key difference in the overall field study methodology for this before-and-after study, as compared to the cross-sectional study discussed in Chapter 7, was that it employed the use of video to record and review both staged and non-staged pedestrian crossings. The consideration of non-staged pedestrian crossings not only provided a broader sample with which to analyze driver yielding, but it also allowed researchers to study pedestrians' behavior at crosswalks treated with these treatments. The observer documented each non-staged crossing, including driver yielding in each direction of vehicular travel, in the same manner as staged crossings, but the video allowed researchers to review any missed non-staged crossings (e.g., jaywalkers near the crosswalk) and to obtain further information on pedestrian behavior characteristics. The review of pedestrian behavior in the video review process will be discussed in more detail in the Data Reduction section of this chapter.

The field study team identified a location to position a TTI-owned video trailer such that it had an unobstructed view of the crosswalk and approaching roadways, but that it was located several hundred feet away to reduce its conspicuity and minimize the effects of the trailer's presence; in the example shown in Figure 17, the crosswalk is at the crest of the hill in the center of the picture, approximately 500 ft from the trailer shown at the right of the picture. The trailer is outfitted with a telescoping mast and two cameras, enabling researchers to obtain two views of the crosswalk area from approximately 30 ft in height. For this study, researchers used one camera to obtain a wide angle view and the other to obtain a close view of the crosswalk. Figure 18 provides a sample image showing the two views.

The camera providing the close view of the crosswalk and related treatments was aimed to capture a detailed look at the pedestrians who approached the crosswalk (including a view of the pushbutton, if present), the pedestrians' path through the crosswalk, and the pedestrians' departure to the sidewalk on the other side of the street. The views of the vehicular approaches included the SSD markers so that researchers could readily identify whether each approaching vehicle had sufficient distance to stop or yield, and thereby determine whether to include the vehicle in the count of yielding or non-yielding vehicles. The views also permitted observation of where the pedestrian waited at the crosswalk and whether the traffic control device was activated.

Researchers recorded activity at each study site for approximately 6 hours, to document not only the staged pedestrian crossings, but also any non-staged activity in both the off-peak and peak conditions.





**Figure 17. Example of Trailer Position.**



**Figure 18. Screenshot of Video of Staged Crossing.**

### **Study Site Description**

To identify study sites for this study, researchers focused on locations where an RRFB or PHB installation was being considered within the timeframe of this research project but was not yet implemented. Coordinating with officials from the cities of Frisco, Garland, San Antonio, and Waco, researchers identified eight sites at which to collect field data, and treatments were installed at five of those sites during the study. A summary of the five study sites is shown in Table 56.

In conjunction with collecting driver yielding data, researchers also documented the characteristics of each study site. The information on the form was supplemented by researchers'

annotations on aerial photographs of each site, as well as digital pictures researchers took of each vehicular and pedestrian approach to the crosswalk, the crosswalk itself, the crossing treatment (if present), and any other notable features at the site. All study site information was compiled into a database for use in analysis.

**Table 56. Study Site Characteristics.**

Site	City	Posted Speed Limit (mph)	Number Through Lanes	Turning Lanes <sup>a</sup>	Before Treatment <sup>b</sup>	After Treatment <sup>b</sup>
FR-01	Frisco	45	4	LTL+RTL	1, 2	1, 2, 4
GA-18	Garland	35	4	TWLTL	1, 2, 3	1, 2, 4
GA-19	Garland	40	6	LTL	1, 2	1, 2, 4
SA-01	San Antonio	30	5	TWLTL	None	1, 5
W-04	Waco	30	4	TWLTL	1, 2	1, 2, 4

<sup>a</sup> Turning Lanes is the type of turning lanes present at the crosswalk, in addition to the through lanes, where:  
LTL = left-turn lane  
RTL = right-turn lane  
TWLTL = two-way left-turn lane

<sup>b</sup> Treatments are coded as follows:  
1 Marked crosswalk  
2 School crossing (S1-1) sign  
3 Roadside flashing beacon  
4 Rectangular rapid-flashing beacon  
5 Pedestrian hybrid beacon

### Data Collection

Collection of field data at the study sites generally followed the defined protocol, with members of the research team working as staged pedestrians and observers. Initially, the goal was to collect 20 staged crossings in each direction at each site, but this was expanded to 30 crossings in each direction for the treated sites in Waco and San Antonio, and four additional crossings were completed at GA-18 before the treatment was installed. At GA-19 and SA-01, in the observation period before the crossing treatment was installed, traffic conditions necessitated concluding data collection shortly before all 20 crossings in each direction were completed; those two sites were concluded with 36 and 39 total crossings. Similarly, the goal was to collect 6 hours of video for each study period, but weather/lighting conditions and technical difficulties shortened that period for selected sites.

During the study period, the observer documented the yielding data for each staged crossing, as well as non-staged crossings at the crosswalk and any jaywalking pedestrians that could be documented during on-site observations. The on-site observations were verified and supplemented as needed during data reduction in the office. Table 57 summarizes the data collected at each site before and after treatments were installed, showing the number of hours in each study period and the number of staged and non-staged crossings at the crosswalk. Non-

staged crossings are subdivided based on whether they occurred during an active school zone. A non-staged crossing event could include more than one pedestrian, a feature that will be discussed in further detail in the Data Analysis section.

**Table 57. Data Overview for Study Sites.**

Site	Period	Date of Data Collection	Hours of Video Collected/Reduced	Staged Crossing Events	Non-Staged Crossing Events – Active School Zone	Non-Staged Crossing Events – Inactive School Zone
Study treatment installed for after period: RRFB						
FR-01	Before	08/28/12	5	40	14	10
	After	10/09/12	6	40	24	9
GA-18	Before	08/30/12	6	48	NA	31
	After	10/11/12	5	40	NA	24
GA-19	Before	08/29/12	6	36	22	7
	After	10/10/12	5	40	18	7
W-04	Before	03/20/13	6	40	0	0
	After	06/04/13	6	60	1	6
Study treatment installed for after period: PHB						
SA-01	Before	11/20/12	6	39	NA	6
	After	06/11/13	4	60	NA	24
NA = Not applicable (no school zone at this site)						

### Data Reduction

After completing the field data collection at a site, researchers returned to the office and entered the crossing data and the site characteristics data from the field worksheets into an electronic database. Researchers then viewed the video recordings from the site, comparing the activities on the video to the information in the database. The data were reviewed for possible transcription errors, data entry errors, and missed non-staged crossings. Researchers made any needed revisions or additions to the data in the database and then formatted the data for analysis.

While reviewing the video recordings, researchers also obtained additional details about pedestrian behavior in non-staged crossings at treated sites. In particular, the review looked for eight characteristics of each non-staged crossing maneuver:

- Active use of electronics by crossing pedestrian:
  - Yes/No/Unclear in video.
- Pedestrian waiting position prior to crossing:
  - Top of ramp/Bottom of ramp/Foot in travel lane or parking lane/Did not wait.
- Pedestrian searching behavior:
  - Did not look/Looked in one direction/Looked in two directions/Repeatedly looked in one or both directions/Unclear in video.
- Pedestrian behavior when starting crossing:
  - Normal/Hesitated/Aborted after starting/Complied with crossing guard instructions/Waited in road.

- Pedestrian crossing mode:
  - Normal walking/Ran/Used wheeled apparatus (bicycle, skateboard, etc.)/Used disability-enabling apparatus (wheelchair, walker, etc.)/Slow crossing (slower than normal walking, but not using an apparatus).
- Crossing apparatus type:
  - Description of apparatus used by crossing pedestrian (if applicable).
- Pedestrian behavior while approaching second lane:
  - Observed no threat/Stopped to wait for approaching vehicle to yield/Avoidance action.
- Number of pedestrians in crossing group.

Documentation of these characteristics provided additional insight into the behavior of pedestrians at the selected crosswalks. Active use of electronics could suggest a distracted pedestrian, providing a possible explanation if a treatment was not activated, or if the pedestrian did not adequately search the roadway before crossing. Waiting position is an indicator of the patience or aggressiveness of a crossing pedestrian, as is the behavior when starting a crossing. Crossing mode allows the analysis to account for pedestrians who needed assistance or who used a method other than typical walking. The pedestrian's response while approaching the second lane offered insight into the frequency of a multiple-threat crossing for multilane approaches, and documenting the number of pedestrians allows the analysis to consider any differences between individuals and groups. The details of the effects of these characteristics are discussed in the Data Analysis section.

## **DATA ANALYSIS**

Researchers performed analysis on the reduced data to identify trends and patterns in the data. Analysis efforts focused on the following:

- Compare driver yielding rates before and after installation of the pedestrian treatment.
  - For all pedestrian crossings.
  - For staged pedestrian crossings.
  - By direction of vehicle travel.
- Identify any changes in non-staged pedestrian crossing volumes after installing treatments.
- Identify any trends in non-staged pedestrian crossing behavior before and after installing treatments.

### **Driver Yielding Rates**

To begin the analysis, researchers first reviewed driver yielding rates for staged and non-staged pedestrians at each site, and compared same-site yielding rates before and after installation of the pedestrian treatment. A vehicle was considered to be in position to yield if it was upstream of the SSD marker when a pedestrian was positioned at the edge of the crosswalk and a driver in front of them did not yield. Of the vehicles in a position to yield, a vehicle was considered to be yielding if the driver slowed or stopped for the purpose of allowing the waiting pedestrian to cross. Any vehicles traveling in a platoon behind yielding vehicles were not counted because those drivers did not have the opportunity to make a decision on whether to yield; therefore, the

maximum number of yielding vehicles possible for each crossing maneuver was equal to the number of travel lanes through which the crosswalk passes.

Each such vehicle that did not yield was counted, as was each yielding vehicle. Yielding was observed separately for each direction of vehicular travel because Texas law is written such that drivers must yield to pedestrians in or approaching their half of the roadway. Thus, yielding was categorized as “nearside” for vehicles traveling on the half of the roadway where the pedestrian began crossing and “farside” for vehicles traveling on the other half of the roadway, where the pedestrian finished crossing.

The yielding rate was then calculated as follows:

$$\text{Yielding rate} = \frac{\text{number of yielding vehicles}}{\text{number of yielding vehicles} + \text{number of non-yielding vehicles}} \quad [2]$$

#### *Yielding for All Pedestrian Crossings*

Yielding rates were calculated for nearside yielding, farside yielding, and total yielding (e.g., the sum of both sides of the roadway). The observed yielding data from each study site for all pedestrian crossings (i.e., staged and non-staged at the crosswalk, and jaywalking) are shown in Table 58.

**Table 58. Driver Yielding at Before-and-After Study Sites.**

Site	Period	Total Crossing Events	Yielding Vehicles			Non-Yielding Vehicles			Yielding Rates (%)		
			Near	Far	Total	Near	Far	Total	Near	Far	Total
Study treatment installed for after period: RRFB											
FR-01	Before	64	62	29	91	94	55	149	40	35	38
	After	75	119	103	222	30	14	44	80	88	83
GA-18	Before	98	34	59	93	167	27	194	17	69	32
	After	66	66	67	133	12	14	26	85	83	84
GA-19	Before	70	34	52	86	317	261	578	10	17	13
	After	65	135	130	265	13	10	23	91	93	92
W-04	Before	41	0	4	4	143	30	173	0	12	2
	After	76	33	53	86	98	44	142	25	55	38
Study treatment installed for after period: PHB											
SA-01	Before	45	0	0	0	138	119	257	0	0	0
	After	118	95	117	212	30	107	137	76	52	61

Yielding rates for all pedestrian crossings at untreated sites were typically below 40 percent. For the treated sites, however, each showed a noticeable improvement in the number of yielding vehicles and the corresponding yielding rates after the treatments were installed, with total yielding rates increasing by 35 to 79 percentage points. GA-19 and SA-01 showed the largest improvements in yielding rates, with an increase of nearly 80 percentage points at GA-19 and between 50 and 80 points at SA-01.

At GA-19, the total number of vehicles approaching the crosswalk in the after period actually declined by nearly 400 due to the sharp drop in non-yielding vehicles; in the before period, 578 of 664 vehicles did not yield, compared to 23 of 288 vehicles in the after period. As the first vehicle in a platoon yields, the vehicles behind it are also forced to yield, reducing the volume of traffic entering the crosswalk while a pedestrian waits to cross.

While W-04 did show substantial improvement in yielding after the RRFB treatment was installed, it did not see as much improvement as other sites. There are several potential reasons for this (e.g., five-lane arterial posted at 30 mph, S-curve in the alignment at the crosswalk, incomplete sidewalk accessibility, etc.) possibly leading to low crossing volumes and increased likelihood that approaching drivers do not pay attention to the crosswalk except during school-zone periods with the crossing guard present. Even with the presence of those site characteristics, the driver yielding at the site improved 20 to 40 percentage points after installation of an RRFB.

#### *Yielding for Staged Pedestrian Crossings*

To get a better comparison of similar conditions at each site, researchers also reviewed results for only staged crossings. Reviewing only the staged crossings allowed for a comparison with similar numbers of crossings as well as a consistent crossing method, eliminating variability that might occur when considering non-staged pedestrians at the crosswalk as well as jaywalking pedestrians. Yielding data for staged crossings are shown in Table 59.

**Table 59. Driver Yielding to Staged Crossings at Before-and-After Study Sites.**

Site	Period	Staged Crossings	Yielding Vehicles			Non-Yielding Vehicles			Yielding Rates (%)		
			Near	Far	Total	Near	Far	Total	Near	Far	Total
Study treatment installed for after period: RRFB											
FR-01	Before	40	22	4	26	48	42	90	31	9	22
	After	40	58	57	115	28	11	39	67	84	75
GA-18	Before	48	25	23	48	99	24	123	20	49	28
	After	40	43	40	83	7	9	16	86	82	84
GA-19	Before	36	1	1	2	299	212	511	< 1	< 1	< 1
	After	40	80	74	154	11	9	20	88	89	89
W-04	Before	40	0	4	4	143	30	173	0	12	2
	After	60	29	45	74	94	31	125	24	59	37
Study treatment installed for after period: PHB											
SA-01	Before	39	0	0	0	137	94	231	0	0	0
	After	60	65	83	148	7	1	8	90	99	95

In terms of yielding rates, the treated sites showed similar improvements for staged crossings as they did for all crossings. GA-19 and SA-01 were again the most improved, with yielding rates increasing from essentially zero to nearly 90 percent for the RRFB at GA-19 and above 90 percent for the PHB at SA-01. Yielding rates for staged crossings at GA-18 were similar to those at GA-19, with values in the mid-80s. The yielding rates from those three sites are consistent with findings from other research for RRFBs and PHBs (1, 72), as are the farside and

total yielding rates from FR-01; yielding rates for the RRFB are typically in the 80 percent range, while PHBs are commonly associated with yielding rates of 95 to 98 percent.

### *Nearside and Farside Yielding for Staged Pedestrian Crossings*

Prior to data analysis, researchers speculated whether the crossing treatments would make a difference in nearside yielding as compared to farside yielding. Separately reviewing the yielding rates for staged crossings in Table 59 for the nearside and the farside indicates that farside yielding is at or above the rate of nearside yielding at most of the sites in this study, regardless of treatment. For treated sites, GA-18 is the exception to this finding, but it holds for the other four treated sites. For untreated sites, FR-01 is the only site that does not conform to this trend. Site characteristics such as posted speed limit or median type do not appear to be a factor in this finding, as they vary among the five treated sites (30–45 mph, with both raised and TWLTL median types). It may be that the crossing treatment improves the visibility of the crossing pedestrian for drivers approaching the crosswalk on the farside, motivating them to yield for pedestrians in the middle of the roadway; drivers on the pedestrian's nearside may not have the same motivation, reasoning that the pedestrian can still wait at the curb and can safely wait longer for a gap in traffic. However, the presence of similar rate differentials prior to treatment reduces the certainty of that potential effect.

## **Pedestrian Crossing Volumes**

### *Number of Pedestrian Crossings*

Another research question is whether the installation of crossing treatments induces greater volumes of pedestrians attempting to cross. The reasoning is that pedestrians who might feel uncomfortable crossing at an untreated site are more comfortable with the assistance of a crossing treatment, resulting in an increased number of pedestrian crossings. Table 60 summarizes the number of crossing events at each site.

Looking at the two Garland sites, the number of non-staged crossings at the crosswalks declined somewhat, by seven at GA-18 and by four at GA-19. At GA-18, one factor could be that the observation period was affected by the available lighting at the site. This site is adjacent to a high school, and the observation period was set to cover the morning peak period. In the observation prior to treatment, data were collected in August and observation began around 6:30 a.m.; however, after the treatment was installed and data were collected in October, it was still dark until after 7:00 a.m., and some pedestrians arriving early to school may not have been visible. Similarly, at GA-19, there was a period of rain early in the day that data were collected after the RRFB was installed; the rain required researchers to wait until later in the day to begin collecting data, starting close to 1:30 p.m. instead of the 11:00 a.m. start time in the before period. The shift in time meant that any pedestrians crossing during the noon hour would have been missed, which could account for the lower number of non-staged crossings.

**Table 60. Number of Pedestrian Crossings at Before-and-After Study Sites.**

Site	Period	Study Treatment	Jaywalking Crossings	Non-Staged Crossings	Staged Crossings	All Crossings
FR-01	Before	None	0	24	40	64
	After	RRFB	2	33	40	75
GA-18	Before	None	19	31	48	98
	After	RRFB	2	24	40	66
GA-19	Before	None	5	29	36	70
	After	RRFB	0	25	40	65
W-04	Before	None	0	0	40	41
	After	RRFB	10	6	60	76
SA-01	Before	None	0	6	39	45
	After	PHB	34	24	60	118
All Sites	Before		24	90	203	317
	After		48	112	240	400
	Total		72	202	443	717

Jaywalking at both Garland sites also decreased, from 19 to two at GA-18 and five to zero at GA-19. The presence of an RRFB might have encouraged pedestrians to cross only at the crosswalk, reducing the frequency of jaywalking, but the shifts in time mentioned in the previous paragraph may have also played a role in the number of pedestrians observed, particularly at GA-18.

The number of jaywalkers observed at FR-01 increased from zero to two, and the number of non-staged crossings at the crosswalk increased by nine. This could have been partially the result of an expanded observation period after installation, from 5 hours to 6 hours; however, that additional hour saw only four non-staged crossings, so the remaining increase is still due to additional activity during the same time period observed prior to installation.

At W-04, there was no non-staged activity prior to installation of the treatment, but there were 10 jaywalkers and six non-staged crossings at the crosswalk after installation of the RRFB. Interestingly, there were more pedestrians outside of the crosswalk than at the crosswalk after the RRFB was installed; many of the jaywalkers traveled past the treatment on their route, so they could have used the RRFB-treated crosswalk but chose not to. It is unclear whether the presence of the RRFB had an effect on the number of jaywalkers, but the increase in non-staged crossings at the crosswalk shows a possible relationship.

The greatest change was at the PHB at SA-01. The number of jaywalkers increased from zero to 34 after treatment, and the number of non-staged crossings rose from six to 24. The fourfold increase in non-staged crossings at the crosswalk is logical, considering that the crosswalk was unmarked prior to treatment, and the presence of a PHB provides a red indication to approaching drivers, improving the likelihood that drivers will stop and provide a gap in traffic. The increase in jaywalking volumes, however, was not anticipated. Anecdotal evidence from review of the video suggests that jaywalking pedestrians commonly used the status of the PHB as a reference; they noted when the PHB was activated and, rather than walking the remaining distance to the crosswalk and activating the treatment themselves, they used the gap created by the nearby PHB



to cross the street from where they were located. In each instance, pedestrians would not have had to travel out of their way to use the crosswalk because it was between their origin and destination, but they chose to jaywalk when the gap in traffic was created. While no pedestrians were directly asked about this apparent trend, it seems that they were in fact taking advantage of the presence of the PHB, even if they were not actually at the crosswalk.

Because the PHB provides a red indication to promote stopping at the crosswalk, it typically has a more pronounced effect on vehicular traffic than the yellow indication of an RRFB, as discussed with the results from Table 59. It follows that the benefit to jaywalkers provided by an RRFB would also be less obvious than a PHB. At the RRFB sites, some jaywalkers were observed to wait at the curb upstream of the RRFB to look for a gap in traffic, rather than continue on their path to the crosswalk and attempt a crossing there. Because this observation is based on anecdotal evidence, it is not known whether these pedestrians had an aversion to using the treatment (e.g., they believe that it is only meant for schoolchildren), but this could be a behavioral characteristic that could be more thoroughly addressed through a more specific study that includes an educational outreach component.

#### *Pedestrian Crossings per Hour*

To help account for changes related to the length of the observation period, researchers looked at the number of non-staged and jaywalking crossings per hour. Table 61 summarizes the number of crossing events at each site.

**Table 61. Non-Staged and Jaywalking Crossings per Hour at Before-and-After Study Sites.**

Site	Period	Study Treatment	Jaywalking Crossings Per Hour	Non-Staged Crossings Per Hour
FR-01	Before	None	0.00	4.80
	After	RRFB	0.33	5.50
GA-18	Before	None	3.17	5.17
	After	RRFB	0.40	4.80
GA-19	Before	None	0.83	4.83
	After	RRFB	0.00	5.00
W-04	Before	None	0.00	0.00
	After	RRFB	1.67	1.00
SA-01	Before	None	0.00	1.00
	After	PHB	8.50	6.00

On a per-hour basis, the number of non-staged crossings did not change substantially at the Frisco or Garland sites, remaining close to five crossings per hour regardless of treatment. Because there were no non-staged crossings at W-04 prior to treatment, that hourly rate increased in the after period. As discussed previously, the number of non-staged crossings at SA-01 had a fourfold increase; this resulted in a six fold increase in hourly rate.

The number of jaywalking pedestrian crossings per hour also did not change much at FR-01 and GA-19, at a rate of less than one per hour before and after treatment. The jaywalker rate declined

sharply at GA-18, corresponding to the large decrease in the count of jaywalkers after treatment. The absence of jaywalkers in Waco and San Antonio before treatment produced increasing rates after treatment, but the increase at SA-01 was much more dramatic because of the larger number of crossings.

### Non-Staged Pedestrian Behavior

Related to the previous discussion of pedestrian behavior, researchers wanted to know whether certain patterns of activities could be identified at the installed treatments. To that end, researchers documented eight characteristics of each non-staged crossing maneuver at treated sites, as well as whether the pedestrian activated the treatment.

#### *Activation*

One of the first indications that a crossing treatment will be effective is whether pedestrians use the treatment that is provided; researchers reviewed the video for each non-staged pedestrian crossing at treated sites to determine whether those pedestrians pushed the button to activate the treatment. The vast majority (94 percent) of such pedestrians did activate the treatment provided, though only one-third (2 of 6) of those crossing at W-04 did so. A summary is shown in Table 62. To obtain the full benefit of the PHB treatment, pedestrians at SA-01 also needed to wait for their walk signal before crossing; all 24 non-staged pedestrians did.

**Table 62. Non-Staged Pedestrian Activation at Treated Study Sites.**

Site	Study Treatment	Activated Treatment	Did Not Activate Treatment	Waited for WALK Signal	Total Pedestrians
FR-01	RRFB	33	0	NA	33
GA-18	RRFB	23	1	NA	24
GA-19	RRFB	25	0	NA	25
W-04	RRFB	2	4	NA	6
SA-01	PHB	24	0	24	24
Total		107	5	24	112
NA = Not applicable to RRFB treatment					

#### *Active Use of Electronics*

Researchers reviewed the non-staged pedestrian crossings to determine to what extent those pedestrians were actively involved in the use of an electronic item (e.g., mobile phone, music player, tablet computer) while crossing. If a sizeable number of pedestrians are using electronics and are distracted, it could affect other characteristics of a crossing, such as looking behavior or walking speed. However, minimal use of electronics was documented at the sites in this study. Of the 112 non-staged pedestrian crossings at treated sites, only one of them was observed to have an active electronic item, and the status of another 24 crossings could not be determined from the video. A summary is shown in Table 63. It should be noted that conditions at the study sites were more typical of suburban locations rather than urban locations, which may have higher incidences of pedestrians actively using electronic items while crossing.

**Table 63. Active Use of Electronics by Non-Staged Pedestrian at Treated Study Sites.**

Site	Study Treatment	Active Use of Electronics			
		Yes	No	Unknown	Total
FR-01	RRFB	0	22	11	33
GA-18	RRFB	0	16	8	24
GA-19	RRFB	1	21	3	25
W-04	RRFB	0	5	1	6
SA-01	PHB	0	23	1	24
Total		1	87	24	112

*Pedestrian Waiting Position*

Researchers reviewed the crossings to determine where non-staged pedestrians waited for their opportunity to cross. The staged pedestrian protocol defined that pedestrians would wait at the edge of the crosswalk (e.g., off the edge of the curb or curb ramp) to meet the conditions described by Texas law; however, non-staged pedestrians may wait in a variety of places while looking for a gap in traffic. At the sites in this study, pedestrians tended to wait at the top of the curb, as shown in Table 64. The waiting position of the pedestrian could be related to driver yielding. The driver yielding rates were determined by non-staged pedestrian waiting position (see Table 65). Nearside yielding rates were 100 percent for pedestrians who waited at the edge of the travel lane, though nearside yielding was also high for pedestrians at the top of the curb ramp.

**Table 64. Non-Staged Pedestrian Waiting Position at Treated Study Sites.**

Site	Study Treatment	Top of Ramp	Bottom of Ramp	Foot in Travel Lane or Parking Lane	Did not Wait	Unable to Determine	Total
FR-01	RRFB	16	3	11	0	3	33
GA-18	RRFB	11	7	6	0	0	24
GA-19	RRFB	12	4	7	0	2	25
W-04	RRFB	4	1	0	1	0	6
SA-01	PHB	23	1	0	0	0	24
Total		66	16	24	1	5	112

*Pedestrian Searching Behavior*

Researchers reviewed the video to document whether, and to what extent, pedestrians looked for approaching traffic as they waited to cross; Table 66 summarizes that data. About 90 percent of pedestrians looked in at least one direction, and over half (70 of 112) checked both directions at least once prior to crossing.

**Table 65. Nearside Yielding by Non-Staged Pedestrian Waiting Position.**

Site	Study Treatment	Nearside Yielding Vehicles					Nearside Yielding Rates (%)				
		T	B	L	D	U	T	B	L	D	U
FR-01	RRFB	24	5	26	—	6	96	83	100	—	100
GA-18	RRFB	14	6	3	—	—	93	60	100	—	—
GA-19	RRFB	29	6	14	—	6	100	75	100	—	100
W-04	RRFB	2	2	—	0	—	100	100	—	0	—
SA-01	PHB	25	1	—	—	—	74	100	—	—	—
Total		94	20	43	0	12	90	74	100	0	100

T = Top of ramp  
 B = Bottom of ramp  
 L = Foot in travel lane or parking lane  
 D = Did not wait  
 U = Unable to determine from video  
 — = No Crossings

**Table 66. Non-Staged Pedestrian Searching Behavior at Treated Study Sites.**

Site	Study Treatment	Searching Behavior Code					Total
		0	1	2	3	U	
FR-01	RRFB	7	14	6	6	0	33
GA-18	RRFB	2	10	8	3	1	24
GA-19	RRFB	1	2	11	11	0	25
W-04	RRFB	0	1	1	4	0	6
SA-01	PHB	1	3	12	8	0	24
Total		11	30	38	32	1	112

0 = Did not look before entering roadway to cross  
 1 = Looked in one direction  
 2 = Looked in both directions  
 3 = Repeatedly looked in one or both directions  
 U = Unable to determine from video

For crossing events that were directed by a crossing guard, the responsibilities of the pedestrian change; therefore, a pedestrian may or may not watch for traffic as diligently if a crossing guard indicates it is safe to cross. Table 67 subdivides the data in Table 66, categorizing the crossing events by whether a crossing guard was present. At FR-01, six of the seven crossings where pedestrians did not look before entering the roadway were crossings controlled by a crossing guard, as were 12 of the 14 crossings where the pedestrian looked in only one direction; each time, the crossing guard did look in both directions at least once before beginning the crossing maneuver. At GA-19, 15 of 16 pedestrians looked both ways at least once in the presence of a crossing guard. Only one crossing at W-04 was controlled by a crossing guard, at which the pedestrian repeatedly looked in one or both directions.

**Table 67. Non-Staged Pedestrian Searching Behavior at Treated Study Sites by Presence of Crossing Guard.**

Site	Study Treatment	Crossing Guard Present						Crossing Guard Not Present					
		0	1	2	3	U	Total	0	1	2	3	U	Total
FR-01	RRFB	6	12	2	2	0	22	1	2	4	4	0	11
GA-18	RRFB	—	—	—	—	—	—	2	10	8	3	1	24
GA-19	RRFB	0	1	9	6	0	16	1	1	2	5	0	9
W-04	RRFB	0	0	0	1	0	1	0	1	1	3	0	5
SA-01	PHB	—	—	—	—	—	—	1	3	12	8	0	24
Total		6	13	11	9	0	39	5	17	27	23	1	73

0 = Did not look before entering roadway to cross  
1 = Looked in one direction  
2 = Looked in both directions  
3 = Repeatedly looked in one or both directions  
U = Unable to determine from video  
— = No school zone at this site

*Pedestrian Starting Behavior*

Researchers reviewed each crossing to observe how non-staged pedestrians began their crossing maneuver after making the decision to proceed into the crosswalk. Researchers defined five categories of starting behavior:

- Normal – began crossing and proceeded with no delays.
- Hesitated – began crossing and then waited before proceeding.
- Aborted after starting – began crossing and then returned to curb, not completing the crossing.
- Complied with crossing guard instructions – crossed under the direction of a school crossing guard.
- Waited in road – began crossing but briefly waited in a travel lane for a non-yielding vehicle in an adjacent lane to pass through the crosswalk.

Of those five categories of behaviors, only three were observed: normal, hesitated, and crossing guard. As shown in Table 68, normal crossing behavior was the predominant category, though more than one-third of non-staged crossings occurred as directed by a crossing guard. This suggests that, in general, the pedestrians felt comfortable with their decision to cross as they began their maneuver.

**Table 68. Non-Staged Pedestrian Starting Behavior at Treated Study Sites.**

Site	Study Treatment	Normal	Hesitated	Crossing Guard	Total
FR-01	RRFB	11	0	22	33
GA-18	RRFB	21	3	0	24
GA-19	RRFB	7	2	16	25
W-04	RRFB	5	0	1	6
SA-01	PHB	24	0	0	24
Total		68	5	39	112

*Pedestrian Crossing Mode and Assistive Apparatus*

Researchers observed the manner in which each non-staged pedestrian traveled within the crosswalk; the pace at which pedestrians cross, or the use of an assistive apparatus, can provide an indication of pedestrian comfort or indicate the degree of crosswalk use by pedestrians that need assistance. Researchers defined five categories of crossing mode:

- Normal walking.
- Ran.
- Used wheeled apparatus (e.g., bicycle, skateboard).
- Used disability-enabling apparatus (e.g., wheelchair, walker).
- Slow crossing (i.e., slower than normal walking, but not using an apparatus).

It is important to distinguish between categories of assistive apparatus; the “wheeled” category used in this study describes those that are generally voluntary in nature and often recreational, while “disability-enabling” are more of a necessity to those who use them to increase their mobility. The summary in Table 69 shows that most crossings were categorized as having a normal crossing pace, though all five categories were observed, and a select number of crossings at FR-01 included groups that contained both walking and wheeled pedestrians.

**Table 69. Non-Staged Pedestrian Crossing Mode at Treated Study Sites.**

Site	Study Treatment	Walked	Ran	Wheeled	Disability-Enabling	Slow	Walked/Wheeled	Total
FR-01	RRFB	16	0	9	0	4	4	33
GA-18	RRFB	23	1	0	0	0	0	24
GA-19	RRFB	17	3	4	1	0	0	25
W-04	RRFB	5	0	0	1	0	0	6
SA-01	PHB	18	0	3	3	0	0	24
Total		79	4	16	5	4	4	112

For the crossings where an assistive apparatus was used, researchers recorded the actual type of apparatus; the four observed types observed are summarized in Table 70. The first three were classified as voluntary wheeled apparatus, while the wheelchair was the only disability-enabling apparatus observed.

**Table 70. Assistive Apparatus Used by Non-Staged Pedestrians.**

Site	Study Treatment	Bicycle	Skateboard	Stroller	Wheelchair	Total
FR-01	RRFB	9	4	0	0	13
GA-18	RRFB	0	0	0	0	0
GA-19	RRFB	3	0	1	1	5
W-04	RRFB	0	0	0	1	1
SA-01	PHB	2	0	1	3	6
Total		14	4	2	5	25

*Pedestrian Behavior While Approaching Second Lane*

Another important consideration in pedestrian crossing behavior occurs at crosswalks on multilane roads (i.e., roads with more than one lane in each direction of travel). This consideration is primarily related to the “multiple threat” collision, where a vehicle in the curb lane yields to a crossing pedestrian who begins to cross, but an approaching vehicle in the adjacent lane does not yield and the driver cannot see the pedestrian behind the vehicle that has yielded. Pedestrians may have to take additional action to avoid a collision in such circumstances. Researchers desired to know whether there was a potential pattern of behavior related to the “multiple threat” condition, so they reviewed each non-staged crossing to document what pedestrians did as they approached the subsequent lanes of traffic on the near side of their crossings. Researchers defined three categories of behavior:

- No change (e.g., continued unaffected because no threat was observed; all vehicles yielded or there was no approaching vehicle in the adjacent lanes).
- Stopped to wait for approaching vehicle to yield.
- Took avoidance action (e.g., ran across lane, ran back to previous lane).

In nearly 96 percent of observed crossings (107 of 112), the pedestrian continued across the remaining lanes unaffected; 46 of those crossings did not have multiple vehicles, while pedestrians at 61 crossings did not observe a threat from the adjacent vehicles. Three pedestrians stopped to wait for an approaching driver to make a yielding decision, and two others took some additional action to avoid a potential collision (see Table 71).

**Table 71. Non-Staged Pedestrian Behavior Approaching Second Lane at Treated Study Sites.**

Site	Study Treatment	No 2 <sup>nd</sup> Vehicle	No Threat Observed	Stopped	Avoidance	Total
FR-01	RRFB	7	24	1	1	33
GA-18	RRFB	17	7	0	0	24
GA-19	RRFB	5	20	0	0	25
W-04	RRFB	2	2	2	0	6
SA-01	PHB	15	8	0	1	24
Total		46	61	3	2	112

*Number of Pedestrians in Crossing Group*

Finally, researchers wanted an indication of how many non-staged pedestrians were actually using the treated crosswalk; this was particularly important given the number of non-staged crossings that occurred during school-zone periods. Table 72 shows that over half of the non-staged crossings were completed with only one pedestrian, but other crossings had groups as large as seven; as a result, at least 192 people participated in the 112 non-staged crossings at treated sites in this study.

**Table 72. Number of Non-Staged Pedestrians in Each Crossing Maneuver at Treated Study Sites.**

Site	Study Treatment	1	2	3	4	5	6	7	U	Total
FR-01	RRFB	18	7	1	1	1	0	1	4	33
GA-18	RRFB	11	4	6	2	1	0	0	0	24
GA-19	RRFB	13	9	2	0	0	1	0	0	25
W-04	RRFB	5	0	1	0	0	0	0	0	6
SA-01	PHB	15	7	1	1	0	0	0	0	24
Total		62	27	11	4	2	1	1	4	112

U = Unable to determine from video

**SUMMARY**

This research effort identified the changes in driver and pedestrian behaviors resulting from installing PHB or RRFB treatments at previously untreated crosswalks in Texas. Researchers conducted a field study using a staged pedestrian protocol at five treated sites (1 PHB and 4 RRFBs). In addition to documenting driver yielding behavior for staged pedestrian crossings, activity at each study site was also recorded using a portable video camera to document both the staged and non-staged activity in the off-peak and peak conditions. Overall, installation of treatments improved driver yielding substantially (35–80 percent), with most (94 percent) of the non-staged pedestrians activating the treatment. An increase in the number of non-staged pedestrian crossings was observed after the PHB was installed at the study site. Nearside yielding rates were higher for non-staged pedestrians who waited at the edge of the travel lane than those waiting at the top of the curb ramp. About 90 percent of non-staged pedestrians looked in at least one direction, and over half (70 of 112) checked both directions at least once prior to crossing.

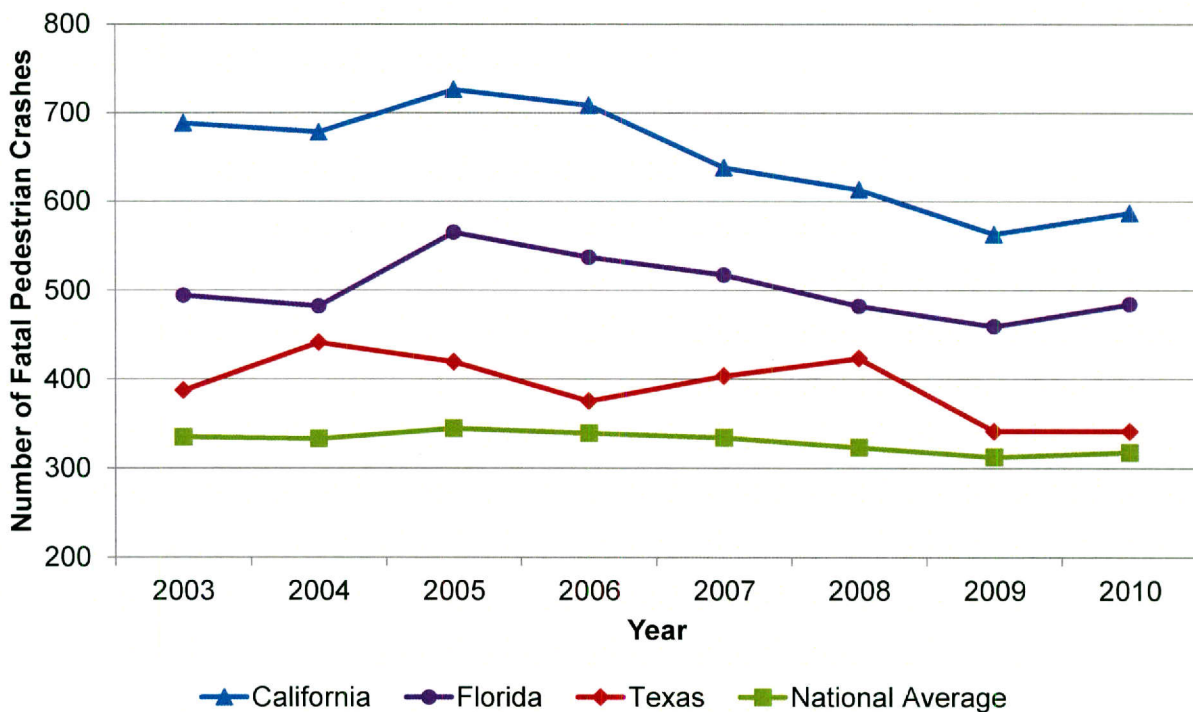


## CHAPTER 9

### IN-DEPTH REVIEW OF TEXAS PEDESTRIAN CRASHES

#### BACKGROUND

In Texas, the average number of pedestrian fatalities has been about 400 per year, over the most recent 5-year period available (2007–2011). Data from NHTSA Fatality Analysis Reporting System (FARS) show that number of pedestrian fatal crashes in Texas is higher than the national average (of all the 50 states and Washington, D.C., reported in FARS) (173). Figure 19 shows a comparison of the national average with California, Florida, and Texas, which are the states with highest number of fatal pedestrian crashes. Texas is considered by the Federal Highway Administration to be a “focus” state due to the high number of pedestrian crashes.



**Figure 19. Comparison of the Number of Fatal Pedestrian Crashes across States (Query Using Injury Severity = 4, Fatal Injury (K) and Person Type = 5, Pedestrian in FARS Data) (173).**

Researchers explored the Texas Department of Transportation Crash Record Information System database to identify characteristics of crashes in which pedestrians were involved. The CRIS data set used for this study spans the years of 2007 to 2011. This data set was certified until 2011 as of June 2012. It includes all crash types on the KABCO Scale (i.e., K=killed, A=incapacitating injury, B=non-incapacitating, C=possible injury, O=not injured/property damage only).

## DATA ASSEMBLY

### Crash Characteristics

The CRIS data have three subsets: crash, person, and unit (i.e., vehicle involved). Each of these subsets was explored to understand pedestrian crashes in Texas. These subsets have different codes that could distinguish crashes involving pedestrians from other reported crashes. The following explains how crashes involving pedestrians were identified in each of the CRIS subsets:

- **Crash** – The information in this data set pertains to crash characteristics (e.g., date, time, weather) and crash location characteristics (e.g., intersection relation, surface condition, traffic control devices). The harmful event variable (HARM\_EVNT\_ID) is defined as the “identifier of the first harmful event.” HARM\_EVNT\_ID = 1 (pedestrian) provides the ability to identify crashes that involved a pedestrian as the first harmful event. From 2007 to 2011, a total of 28,761 crashes were identified with a harmful event of 1 (pedestrians).
- **Person** – The information in this data set describes the characteristics of people involved (e.g., age, gender, blood alcohol content, etc.) and injuries sustained (e.g., fatal, no injury, etc.). The person type variable (PRSN\_TYPE\_ID) is defined as an “identifier for type of person involved in the crash.” PRSN\_TYPE\_ID = 4 (pedestrian) was used to identify pedestrians involved in a crash. Another identifier used is the occupant position variable (PRSN\_OCCPNT\_POS\_ID), defined as “the physical location of an occupant in, on, or outside of the motor vehicle prior to the First Harmful Event or loss of control.” PRSN\_OCCPNT\_POS\_ID = 16 (pedestrian, pedalcyclist, or motorized conveyance) was also used to identify pedestrians involved in a crash. From 2007 to 2011, a total of 47,732 records were identified with either person type 4 or person occupant position 16, representing 44,708 crashes (crashes could have more than one person involved, i.e., more than one record).
- **Unit** – This data set describes characteristics of the vehicles involved (unit) in the recorded crashes. The unit data set also covers details regarding the driver and passengers and the injuries sustained by those involved. The vehicle unit description variable (VEH\_UNIT\_DESC) is an “identifier for vehicle, person, or object involved in the crash.” VEH\_UNIT\_DESC = 4 (pedestrian) provides the ability to identify crashes with pedestrians. Another identifier used is the vehicle type variable (VEH\_TYPE\_ID), which is defined as “the type of vehicle involved in the crash.” VEH\_TYPE\_ID = 21 (pedestrian) also provides the ability to identify crashes with pedestrians. The 2010 and 2011 files did not have the VEH\_TYPE\_ID variable; instead, they have the following variables that were used to identify pedestrian-involved crashes (with a code of 12 representing a “pedestrian”): CMV\_Evnt1\_ID, CMV\_Evnt2\_ID, CMV\_Evnt3\_ID, and CMV\_Evnt4\_ID. From 2007 to 2011, a total of 32,478 records were identified, with either unit description 4 or vehicle type 21, representing a total of 30,388 crashes (crashes could have more than one vehicle involved). No crashes were identified with CMV\_Evnt variables.
- **Combined** – Each crash recorded in the CRIS database has a unique crash ID, which is used to match crashes in the three subsets (crash, person, and unit). Crash IDs of crashes identified as pedestrian related in any of the three subsets are combined to assemble a combined data set. The data set only includes unique crashes involving pedestrians;

duplicate crashes (identified using the Crash\_ID variable) were removed. The combined data set had 45,858 crashes covering the 2007 to 2011 time period.

- **TxDOT-Reportable** – For this study, only TxDOT-reportable crashes are of interest. TxDOT-reportable crashes are those that occur on a traffic way and resulted in injury or death or \$1000 damage. The TxDOT-reportable flag (TxDOT\_Rptable\_Fl) variable was used to identify such crashes in the combined data set. In all, 75 percent of the crashes (34,620 out of 45,858) in the combined data set were TxDOT-reportable (TxDOT\_Rptable\_Fl=Y). In summary, the final pedestrian crash database has crashes with at least one of the following codes:
  - HARM\_EVNT\_ID = 1, crash data set.
  - PRSN\_TYPE\_ID = 4, person data set.
  - PRSN\_OCCPNT\_POS\_ID = 16, person data set.
  - VEH\_UNIT\_DESC = 4, vehicle data set.
  - VEH\_TYPE\_ID = 21, vehicle data set.
  - TxDOT\_Rptable\_Fl = Y, combined data set.

Table 73 shows the number of records by harmful event codes present in the data set. A slight majority of the records (59 percent) were identified with a harmful event code of pedestrian. The remaining records (41 percent) were identified using codes from the person and unit data sets.

**Table 73. Number of Records by Harmful Event Code.**

Harmful Event Code		2007	2008	2009	2010	2011	Total	Percent of Total
1	Pedestrian	4231	4540	4296	3731	3764	20562	59%
2	Motor Vehicle in Transport	450	323	241	273	566	1853	5%
3	RR Train	3	1	6	1	1	12	0%
4	Parked Car	128	119	118	124	125	614	2%
5	Pedalcyclist	1743	2309	2197	1974	2067	10290	30%
6	Animal	5	6	15	4	9	39	0%
7	Fixed Object	130	120	130	110	155	645	2%
8	Other Object	35	16	28	56	43	178	1%
9	Other Non-Collision	25	4	16	8	11	64	0%
10	Overtuned	28	25	35	33	225	346	1%
11	Not Reported	8	5	4			17	0%
<b>Total</b>		<b>6786</b>	<b>7468</b>	<b>7086</b>	<b>6314</b>	<b>6966</b>	<b>34620</b>	<b>100%</b>

Table 74 summarizes the number of records and unique crash IDs available from the person and unit files in CRIS. The table shows that 99 percent of the persons in the TxDOT-reportable database have a person occupant position of 16, which represents a pedestrian.

**Table 74. Number of Records for Pedestrians in Person and Unit Files.**

<b>Pedestrian Identification Variable and Code</b>	<b>Number of Records Involving a Pedestrian</b>	<b>Number of Unique Crash IDs</b>	<b>Percent of Total Unique Crash IDs (34620)</b>
Person Type = 4 (Pedestrian)	23498	22016	64%
Person Occupant Position = 16 (Pedestrian, Pedalcyclist, or Motorized Conveyance)	36530	34242	99%
Unit Description = 4 (Pedestrian)	23684	22151	64%
Vehicle Type = 21 (Pedestrian)	5	5	0.01%
<b>Total</b>	<b>88127</b>	<b>34620</b>	<b>100%</b>

Table 75 summarizes pedestrian crashes as a percentage of all traffic crashes, by severity. The traffic crashes shown in Table 75 are TxDOT-reportable; 82 percent of all traffic crashes from 2007–2011 (2,097,105 out of 2,559,851) were TxDOT-reportable. The table shows that over the most recent 5-year period (2007–2011) analyzed in this study, 2 percent of all traffic crashes are pedestrian related. However, about 15 percent of all fatal crashes are pedestrian crashes. Pedestrian crashes went up in 2011 when compared to 2010. For KABC pedestrian crashes, the increase was 1 percent (5 percent from 4 percent), whereas for K pedestrian crashes, the increase was 3 percent (17 percent from 14 percent).

**Table 75. Pedestrian Crashes as a Percentage of all Texas Traffic Crashes, by Severity (Only Includes TxDOT-Reportable Crashes).**

<b>Year</b>	<b>2007</b>	<b>2008</b>	<b>2009</b>	<b>2010</b>	<b>2011</b>	<b>Overall</b>
All Traffic Crashes	458027	438982	428303	391005	380788	2097105
All Ped Crashes	6786	7468	7086	6314	6966	34620
% Ped Crashes	<b>1</b>	<b>2</b>	<b>2</b>	<b>2</b>	<b>2</b>	<b>2</b>
All KABC Crashes	175488	162871	157493	144280	141098	781230
Ped KABC Crashes	6276	7232	6886	6119	6743	33256
% Ped KABC Crashes	<b>4</b>	<b>4</b>	<b>4</b>	<b>4</b>	<b>5</b>	<b>4</b>
All K Crashes	3101	3126	2817	2752	2744	14540
Ped K Crashes	480	489	402	397	464	2232
% Ped K Crashes	<b>15</b>	<b>16</b>	<b>14</b>	<b>14</b>	<b>17</b>	<b>15</b>

## Geometric Characteristics (from Aerial Photographs)

The TxDOT CRIS database was extended with geometric information from aerial photographs for 2011 TxDOT reportable fatal and injury crashes in Austin, Bryan, Corpus Christi, Laredo, and San Antonio TxDOT Districts. Table 76 lists the information obtained from aerial photographs for both the main road (i.e., the road on which the crash occurred) and the cross road (i.e., the road that intersects with the main road), when applicable. These geometric characteristics for the crash location were obtained by using the latitude-longitude variables in the TxDOT CRIS database. Table 77 shows a distribution of the crashes by TxDOT district and severity.

**Table 76. Geometric Information at a Crash Location Obtained from Aerial Photographs.**

<b>Main Road</b>	Name
	Primary Direction (EW/NS)
	Road Type (One-Way or Two-Way)
	Total Number of Lanes
	Number of Left-Turn Lanes
	Presence of On-street parking? (Y/N)
	Median Type (Barrier/Flush/TWLT/TL/Raised/Divided/None)
	Median Width (ft)
	Crossing Width to refuge – A (ft)
	Crossing Width to refuge – B (ft)
	Crossing Width to refuge – Longer of the two directions (ft)
	Total Crossing Width (ft)
	Presence of Marked Crosswalk? (Y/N)
	Posted Speed Limit (mph)
	Presence of School Zone?(Y/N)
	Presence of Sidewalk? (Y/N)
	Presence of Street Light? (Y/N)
	Functional Class (Freeway, Arterial, or Residential)
	Crash Location (Intersection, Driveway, or Midblock)
	Traffic Control Device Type (Signal, Stop Sign, No Control, or Beacon)
If Crash Location is Intersection or Driveway, Number of Legs	
If Crash Location is Intersection or Driveway, Skewed? (Y/N/NA)	
If Midblock, Distance to Nearest Intersection (ft)	
<b>Cross Road</b>	Name
	Primary Direction (EW/NS)
	Road Type (One-Way or Two-Way)
	Total Number of Lanes
	Number of Left-Turn Lanes

**Table 77. Summary of 2011 Crashes in the Extended Geometric Database by CRIS Road Class, TxDOT District, and Severity.**

Road Class	Austin		Bryan		Corpus Christi		Laredo		San Antonio		Total	
	ABC	K	ABC	K	ABC	K	ABC	K	ABC	K	ABC	K
Interstate	16	10	0	4	1	0	2	1	26	9	45	24
US & State Highway	33	5	16	3	18	6	9	1	56	7	132	22
FM Road	12	4	11	1	8	1	2	1	20	5	53	12
County Road	11	1	2	0	1	2	0	0	20	0	34	3
City Street	299	12	46	0	161	14	119	0	556	17	1181	43
Other Road	2	0	0	0	0	0	0	0	2	1	4	1
<b>Total</b>	<b>373</b>	<b>32</b>	<b>75</b>	<b>8</b>	<b>189</b>	<b>23</b>	<b>132</b>	<b>3</b>	<b>680</b>	<b>39</b>	<b>1449</b>	<b>105</b>

## EXPLORATORY ANALYSIS

### Crash Characteristics

An exploratory analysis of the 34,620 pedestrian crashes in the data set was conducted to obtain an initial understanding of Texas pedestrian crashes. Figure 20 shows the number of TxDOT-reportable crashes identified in the TxDOT CRIS database along with the number of TxDOT-reportable pedestrian crashes. The large numbers of property damage only (PDO) crashes among all traffic crashes can be observed from the large gap between the KABCO and KABC curves (see the filled square and filled triangle curves in Figure 20). The pedestrian-related curves overlap at the bottom of Figure 20 because the number of pedestrian crashes is small compared to the number of total crashes. Figure 21 shows the number of all, injury, and fatal pedestrian crashes by year. The graph shows that there are few crashes with unknown severity and a very small proportion of PDO crashes. The small gap between the pedestrian KABCO and pedestrian KABC lines indicate that few crashes that involve a pedestrian have no injuries. Figure 20 and Figure 21 show that all traffic crashes have seen a downward trend; however, pedestrian, especially fatal, crashes have remained fairly similar over the most recent 5-year period available (2007–2011), with a peak in 2008. “All crashes” and “All Ped Crashes” in the figures represent TxDOT-reportable KABCOU (U=unknown) severity crashes.

Crashes by severity level and TxDOT district are shown in Figure 22, which reveals that serious injury and fatal pedestrian (KA) crashes ranged from 18 percent (Laredo and El Paso) to 64 percent (Childress) of the total pedestrian crashes per district. As illustrated in Table 78, Houston, Dallas, San Antonio, Austin, and Ft. Worth are the districts with the highest number of pedestrian crashes over the most recent 5-year period available (2007–2011). Figure 23 shows the percent change in all pedestrian and fatal pedestrian crashes by district, from 2007 to 2011. As shown in the figure, Yoakum saw the largest decrease and Childress saw the highest increase in all pedestrian crashes. Similarly, Wichita Falls saw the highest decrease and Lufkin saw the uppermost increase in fatal pedestrian crashes.

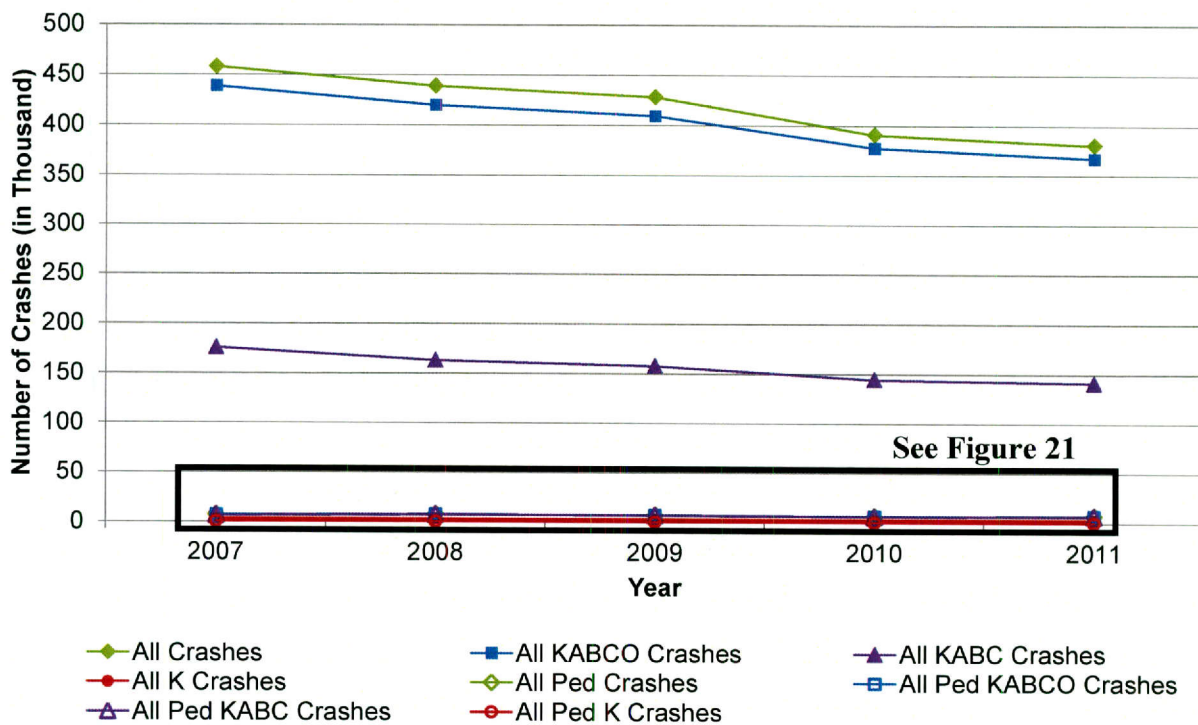


Figure 20. All TxDOT-Reportable Traffic and Pedestrian Crashes (2007–2011).

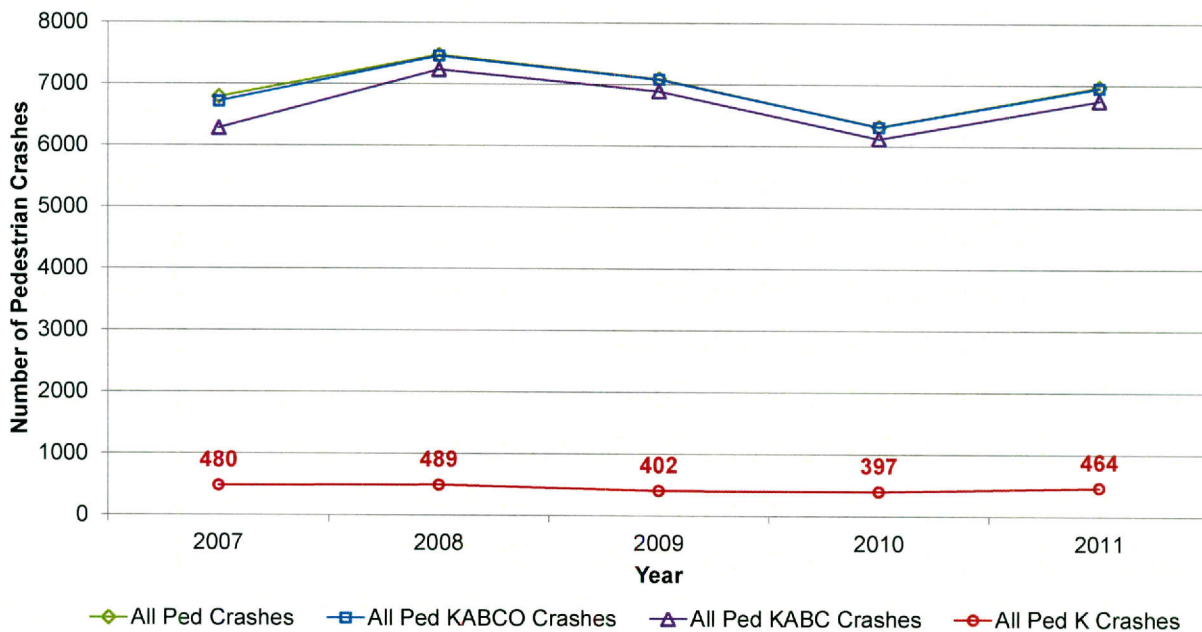
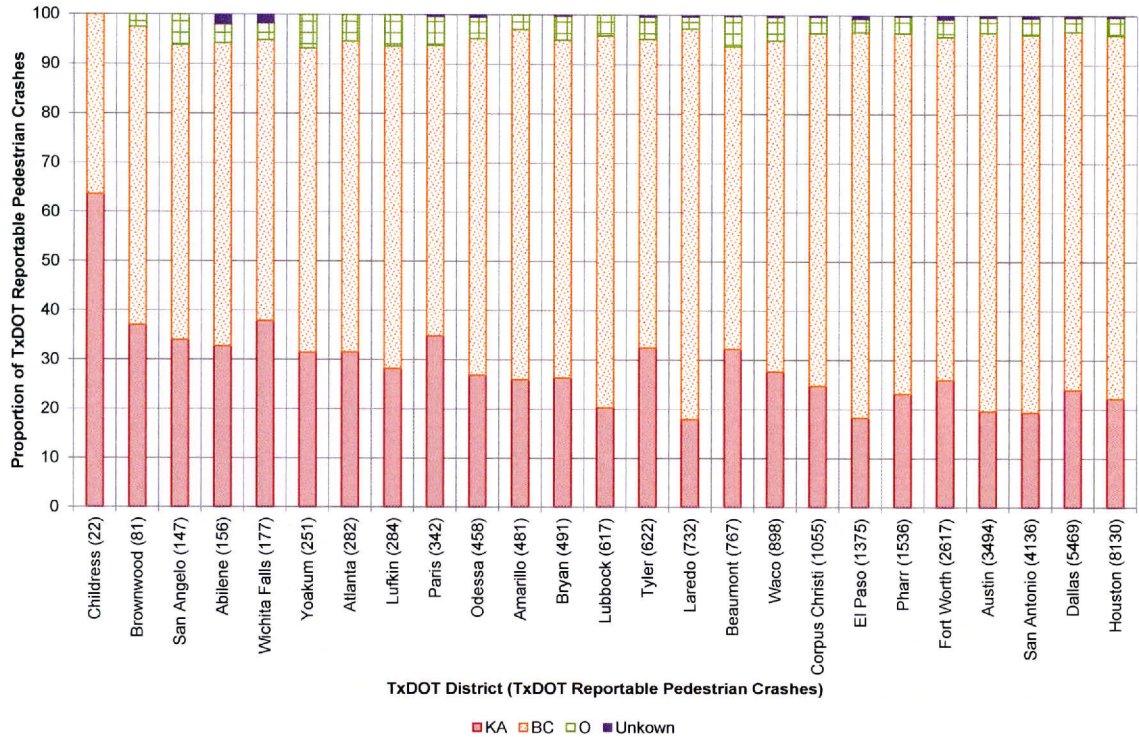
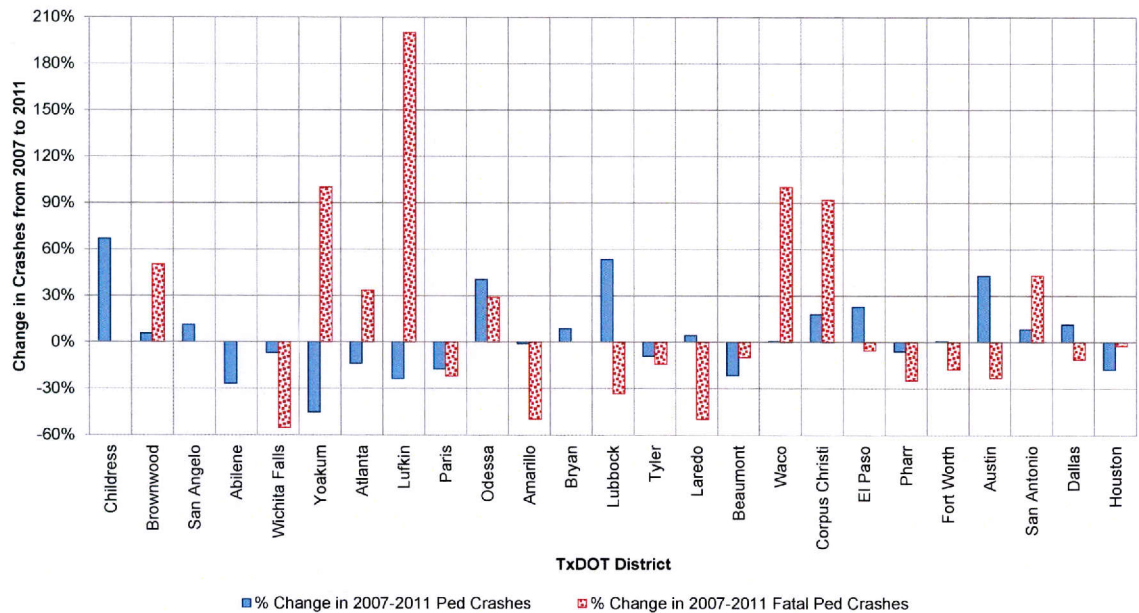


Figure 21. All TxDOT-Reportable Pedestrian Crashes (2007–2011).



**Figure 22. TxDOT-Reportable Pedestrian Crashes by TxDOT District (2007–2011).**



**Figure 23. Percentage Change in TxDOT-Reportable Pedestrian Crashes by TxDOT District (2007–2011).**

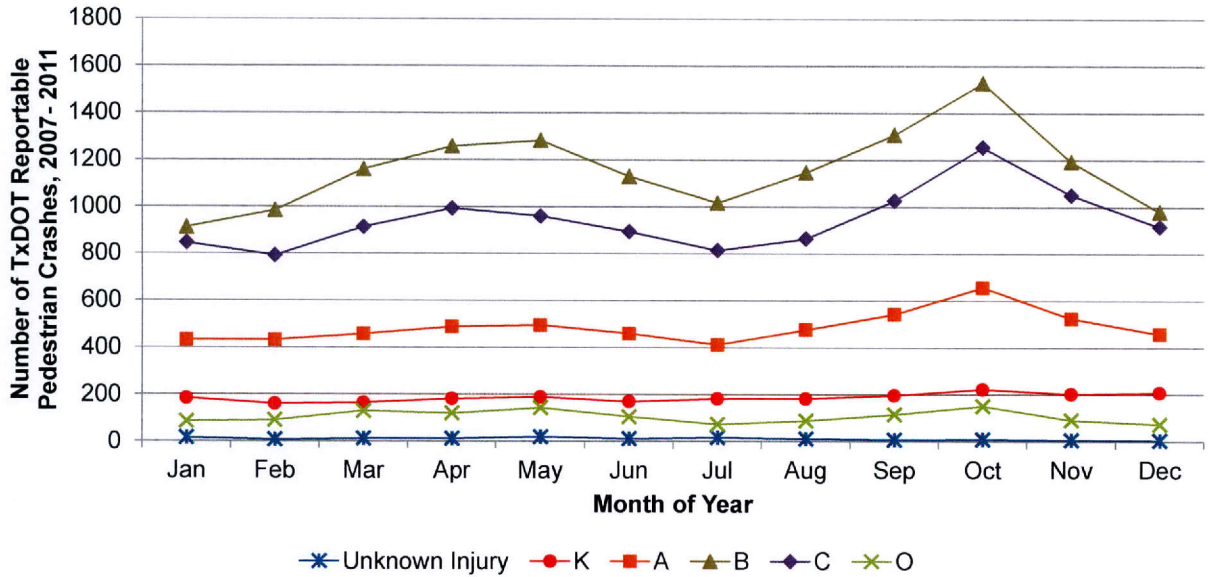


**Table 78. Number of TxDOT-Reportable Pedestrian Crashes by Severity and TxDOT District (2007–2011).**

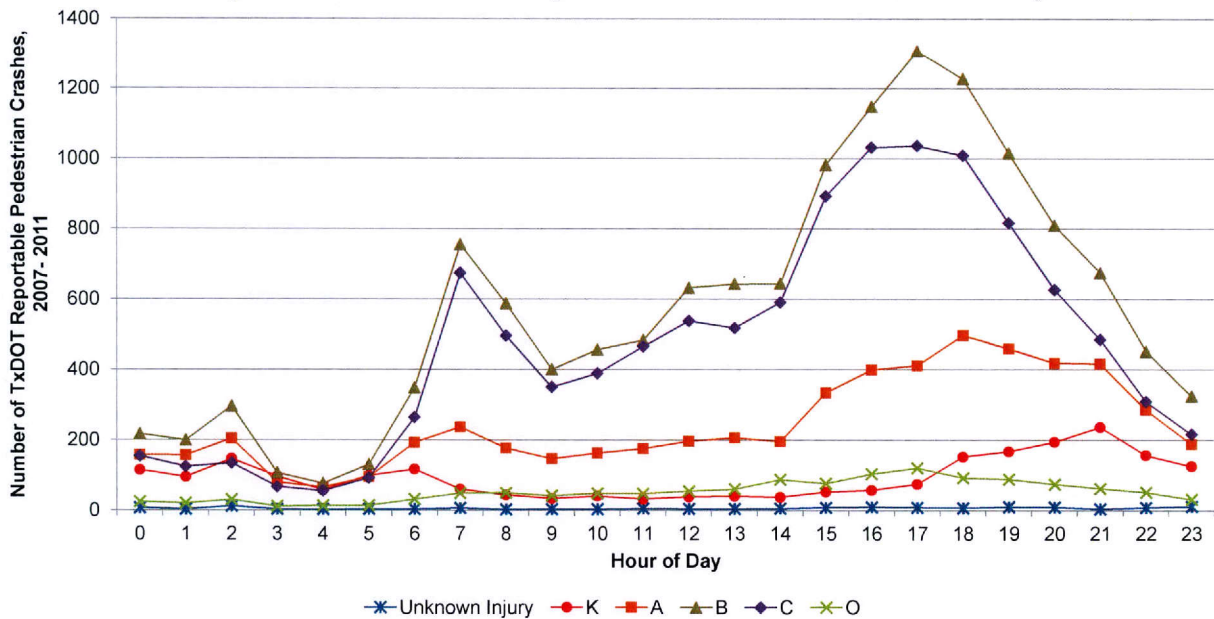
<b>TxDOT District</b>	<b>All Crashes*</b>	<b>KA Crashes</b>	<b>BC Crashes</b>	<b>K Crashes</b>	<b>O Crashes</b>	<b>Unknown Crash Severity</b>	<b>Percent K Crashes</b>
Houston	8130	1803	6001	529	307	19	7%
Dallas	5469	1310	3981	292	161	17	5%
San Antonio	4136	801	3177	193	140	18	5%
Austin	3494	684	2691	148	108	11	4%
Fort Worth	2617	679	1825	174	95	18	7%
Pharr	1536	356	1125	133	53	2	9%
El Paso	1375	251	1078	78	37	9	6%
Corpus Christi	1055	261	756	75	35	3	7%
Waco	898	248	604	78	43	3	9%
Beaumont	767	247	472	86	47	1	11%
Laredo	732	131	581	36	18	2	5%
Tyler	622	202	390	72	28	2	12%
Lubbock	617	125	466	35	26	0	6%
Bryan	491	129	337	37	24	1	8%
Amarillo	481	125	342	40	14	0	8%
Odessa	458	123	313	46	20	2	10%
Paris	342	119	202	39	20	1	11%
Lufkin	284	80	186	21	18	0	7%
Atlanta	282	89	178	31	15	0	11%
Yoakum	251	79	155	24	17	0	10%
Wichita Falls	177	67	101	28	6	3	16%
Abilene	156	51	96	11	6	3	7%
San Angelo	147	50	88	13	9	0	9%
Brownwood	81	30	49	10	2	0	12%
Childress	22	14	8	3	0	0	14%
<b>Total</b>	<b>34620</b>	<b>8054</b>	<b>25202</b>	<b>2232</b>	<b>1249</b>	<b>115</b>	<b>6%</b>

\*All crashes include all severity levels (KABCO) including the crashes with unknown severity. K=killed, A=incapacitating injury, B=non-incapacitating, C=possible injury, O=not injured/property damage only

Figure 24 shows variation in pedestrian crashes with the hour of the day and month of the year by severity of the crash. Over the most recent 5-year period available (2007–2011), October has been the month with the most pedestrian crashes in Texas. This trend is also observed nationally (174). Another peak is observed in April to May. Through the day, three peaks are observed for pedestrian crashes. AB and C types of crashes peak in the PM peak hour (5–6 p.m.), while K type of crashes peak at 9 p.m. The other two peaks are observed at 7 a.m. and 2 a.m.



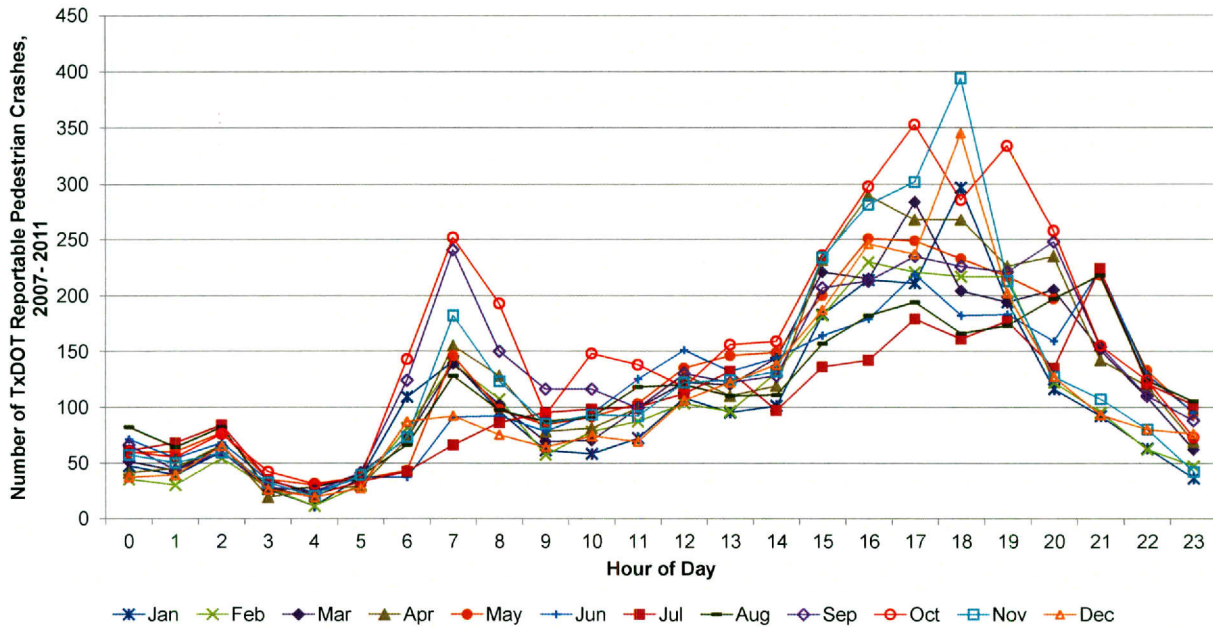
a) Pedestrian Crashes by Month of Year and Crash Severity



b) Pedestrian Crashes by the Hour of Day and Crash Severity

Figure 24. TxDOT-Reportable Pedestrian Crashes by Month of Year and Hour of Day and Crash Severity (2007–2011).

Figure 25 shows the seasonal variation in pedestrian crashes by the hour of the day. This graph supports what was observed in Figure 24a and Figure 24b. In general, October has the highest number of crashes, and the nighttime peak is staggered by month, probably a reflection of changing sunset times.



**Figure 25. TxDOT-Reportable Pedestrian Crashes by Hour of Day and Month of Year (2007–2011).**

Table 79 compares fatal and non-fatal pedestrian crashes among rural and non-rural locations. As shown in the table, approximately 85 percent of all pedestrian crashes and 70 percent of all fatal pedestrian crashes were found to be at non-rural locations. This could be an indication of lower exposure in terms of fewer pedestrians in the rural areas.

**Table 79. TxDOT-Reportable Pedestrian Crashes by Severity and Rural Flag (2007–2011).**

Crash Severity/ Crash Location	Urban	Rural	Total
<b>Non-Fatal</b>	27966	4422	32388
<b>Fatal</b>	1558	674	2232
<b>Total</b>	29524	5096	34620

Table 80 summarizes pedestrian crashes with respect to their proximity to intersections. Approximately 47 percent of the available pedestrian crash data were found to be non-intersection related, and approximately 53 percent were either in the intersection/driveway or related to the intersection.

**Table 80. Number of TxDOT-Reportable Pedestrian Crashes (KABCO) with Respect to Proximity to an Intersection.**

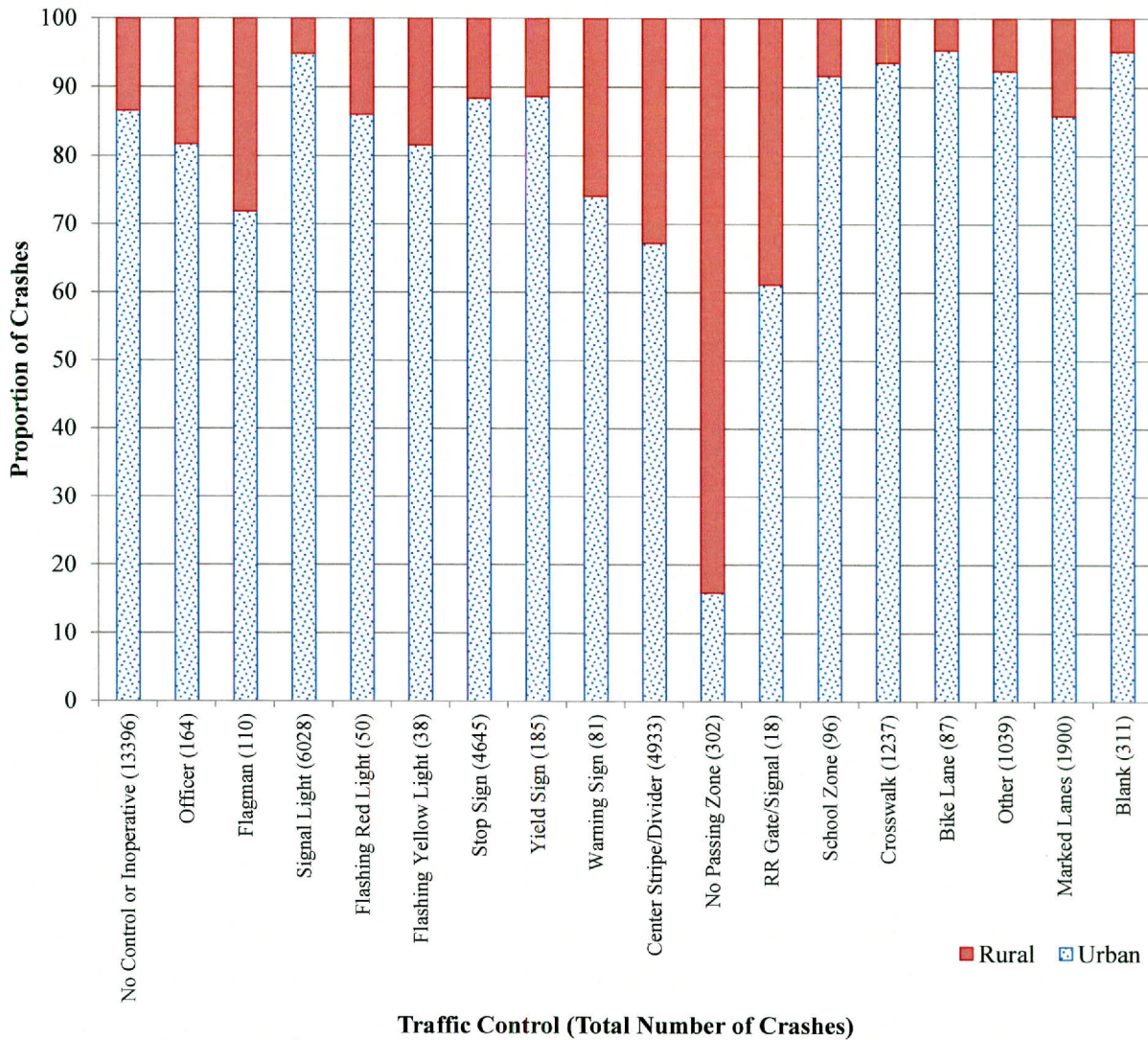
<b>Intersection Relation Variable</b>	<b>2007</b>	<b>2008</b>	<b>2009</b>	<b>2010</b>	<b>2011</b>	<b>Total</b>	<b>Percent</b>
<b>Intersection</b>	1281	1553	1462	1505	1132	6933	20%
<b>Intersection Related</b>	1431	1668	1829	1463	2154	8545	25%
<b>Driveway Access</b>	623	692	661	410	549	2935	8%
<b>Non-Intersection</b>	3442	3549	3134	2936	3130	16191	47%
<b>Not Reported</b>	9	6			1	16	0.05%
<b>Total</b>	6786	7468	7086	6314	6966	34620	100%

Table 81 summarizes pedestrian crashes with respect to their location in relation to the vehicle traveled way. As shown in the table, 89 percent of the pedestrian crashes occurred on the roadway, while 2 percent occurred on the shoulder and 0.2 percent on the median.

**Table 81. Number of TxDOT-Reportable Pedestrian Crashes (KABCO) by Location.**

<b>Intersection Related Variable</b>	<b>On Roadway</b>	<b>Off Roadway</b>	<b>Shoulder</b>	<b>Median</b>	<b>Not Applicable</b>	<b>Not Reported</b>	<b>Total</b>	<b>Percent</b>
<b>Intersection</b>	6786	29	25	5	1	87	6933	20%
<b>Intersection Related</b>	7973	360	54	19	2	137	8545	25%
<b>Driveway Access</b>	1992	784	75	7	9	68	2935	8%
<b>Non-Intersection</b>	14183	1240	417	52	57	242	16191	47%
<b>Not Reported</b>	13	0	0	0	0	3	16	0.05%
<b>Total</b>	30947	2413	571	83	69	537	34620	100%
<b>Percent</b>	89%	7%	2%	0.2%	0.2%	2%	100%	

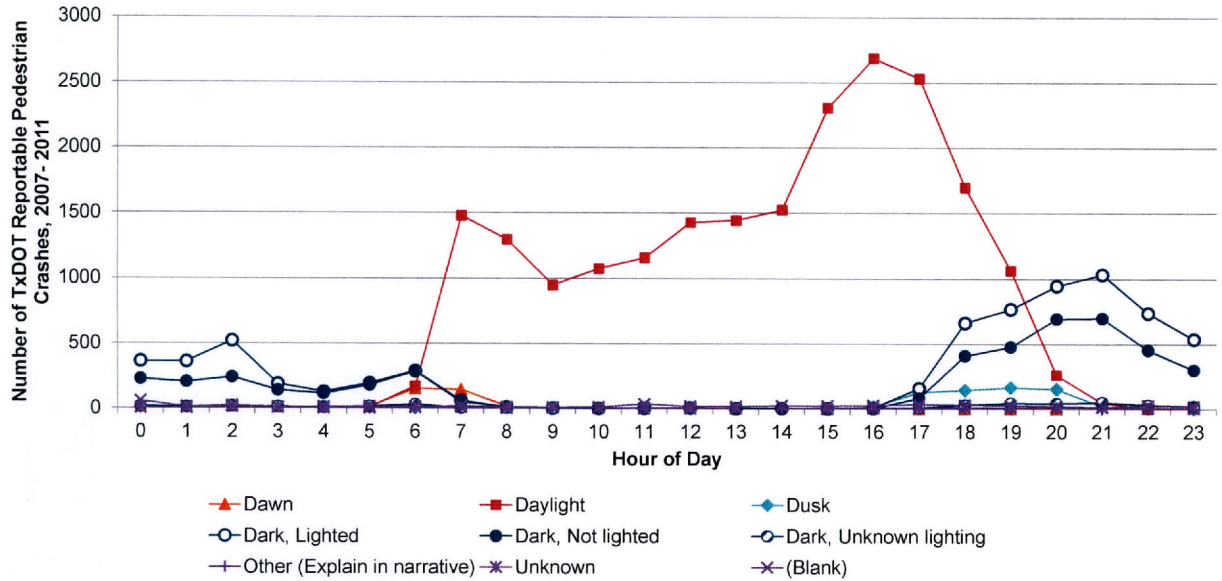
Figure 26 compares pedestrian crashes flagged as rural or non-rural by the traffic control device at the crash location. As shown in the figure, most pedestrian crashes are at locations with no traffic control device, followed by locations with a traffic signal. Also, approximately 85 percent of pedestrian crashes in a no-passing zone occurred at rural locations. This could also be an indication of the fact that no-passing zones are more common in rural locations.



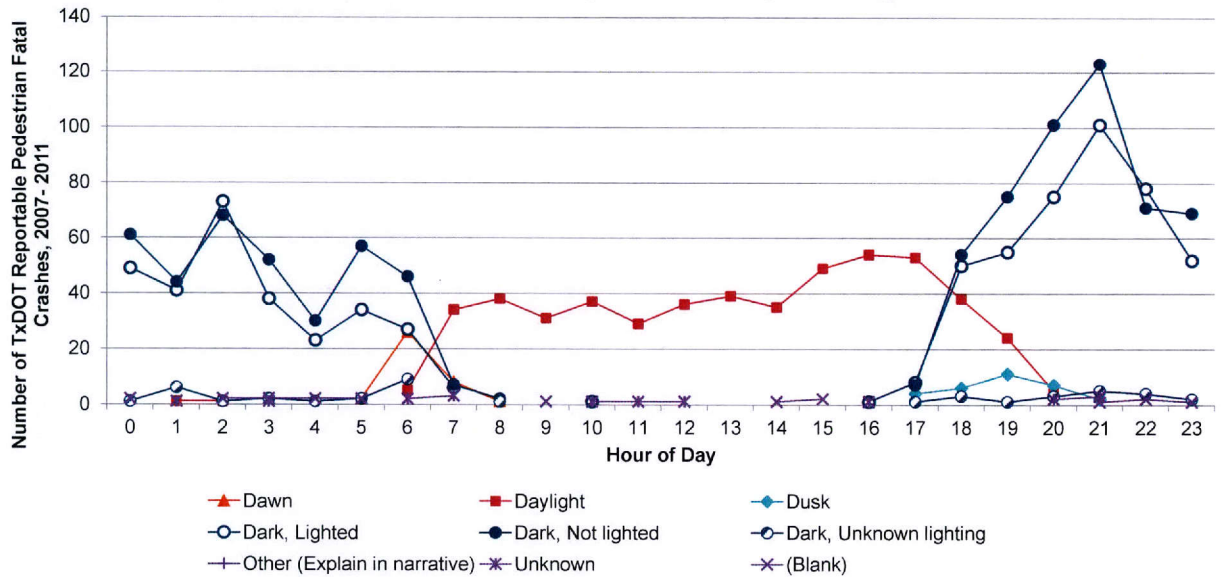
**Figure 26. TxDOT-Reportable Pedestrian Crashes by Traffic Control and Rural Flag.**

Figure 27 summarizes pedestrian crashes by light condition and hour of the day. Figure 28 shows the total number of pedestrian crashes by light condition and fatal crash flag. The majority of the crashes (21,148/34,620 or 61 percent) occurred during daylight. Also, fatal crashes were more common in the “dark, not lighted” conditions. The data in Figure 27 support Figure 28 in that it also shows that 61 percent of pedestrian crashes occurred during daylight, but for fatal pedestrian crashes only 23 percent of crashes occurred in daylight and 39 percent of crashes occurred in the “dark, not lighted” conditions. Figure 29 compares pedestrian crashes by weather condition, showing that most pedestrian crashes occurred in clear/cloudy conditions.

Figure 30 shows the distribution of pedestrian crashes across various roadway classes. As shown in the figure, overall most pedestrian crashes (68 percent or 23,429/34,620) occurred on city streets and most fatal pedestrian crashes (38 percent) occurred on Interstates (24 percent) or U.S. and State highways (14 percent).



**a) All Pedestrian Crashes by Hour of Day and Light Condition**



**b) Pedestrian Fatal Crashes by Hour of Day and Light Condition**

**Figure 27. TxDOT-Reportable Pedestrian Crashes by Hour of Day and Light Condition (2007–2011).**

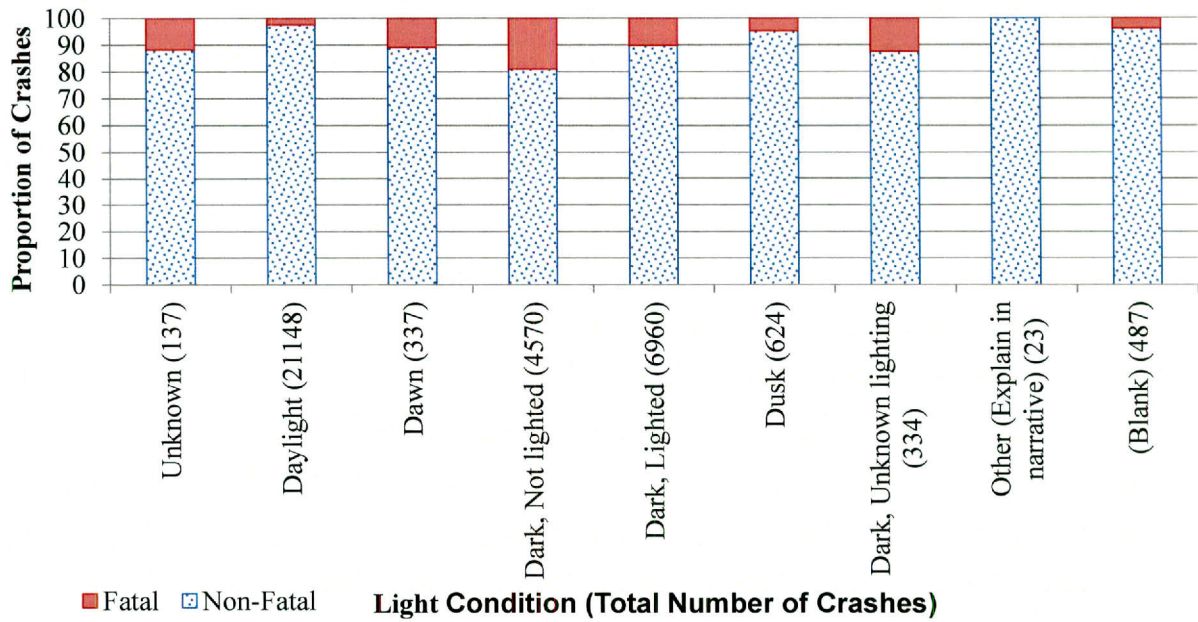


Figure 28. TxDOT-Reportable Pedestrian Crashes by Light Condition and Crash Severity.

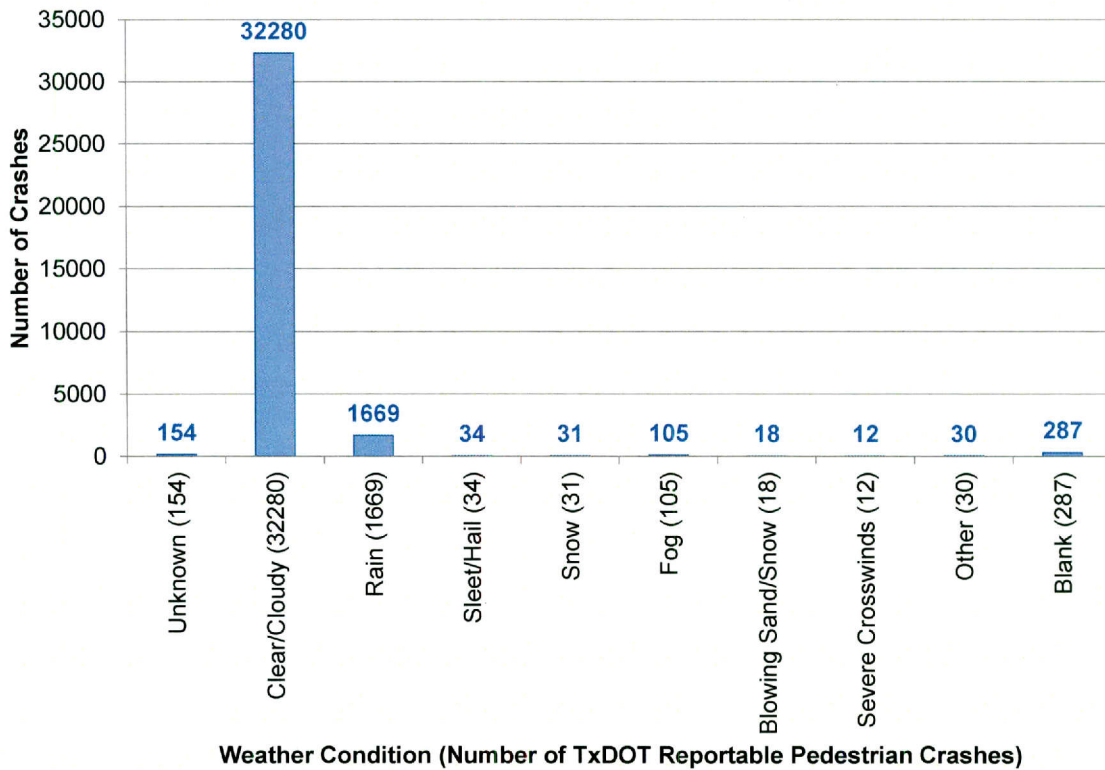
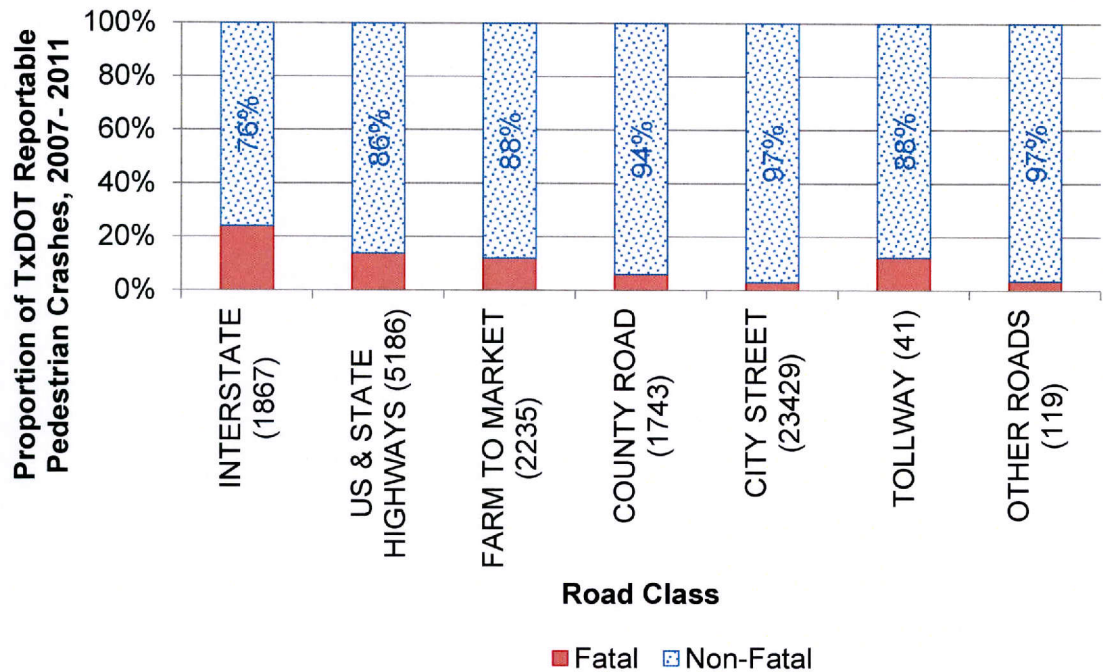


Figure 29. TxDOT-Reportable Pedestrian Crashes by Weather Condition, Crash Severity and Rural Flag (2007–2011).



**Figure 30. TxDOT-Reportable Pedestrian Crashes by Road Class and Crash Severity (2007–2011).**

### Geometric Characteristics (from Aerial Photographs)

A total of 1554 TxDOT reportable injury and fatal crashes occurred in Austin, Bryan, Corpus Christi, Laredo, and San Antonio TxDOT Districts in 2011. Table 82 shows the distribution of these crashes by the functional class identified from aerial photographs. The districts chosen for this sub-study represent high and low pedestrian crash frequency areas in the state. As shown in Table 82, a higher proportion of injury crashes occurred on arterials, whereas equal proportions of fatal crashes occurred on arterials and freeways. Forty-four percent is a considerably high proportion of fatal pedestrian crashes on freeways, where pedestrians are not expected. Ninety-five percent (1472/1554) of the fatal and injury crashes in these select TxDOT districts were on two-way roads, and 94 percent (1467/1554) of the crashes were outside school zones. Most of the crashes (78 percent, 1208/1554) occurred on roadways without on-street parking, and as shown in Table 83, 1041 of the 1554 crashes occurred at locations with roadway lighting and a sidewalk.

**Table 82. Distribution of 2011 TxDOT-Reportable Fatal and Injury Crashes in Select TxDOT Districts by the Functional Class Identified From Aerial Photographs.**

Functional Class	Injury Crashes		Fatal Crashes		Total	
	Frequency	Percentage	Frequency	Percentage	Frequency	Percentage
Arterial	1016	70%	46	44%	1062	68%
Freeway	108	7%	46	44%	154	10%
Residential	325	22%	13	12%	338	22%
Total	1449	100%	105	100%	1554	100%



**Table 83. Distribution of 2011 TxDOT-Reportable Fatal and Injury Crashes in Select TxDOT Districts by Presence of Roadway Lighting and a Sidewalk.**

Main: Presence of Roadway Lighting	Main: Presence of a Sidewalk		Total	Percentage
	No	Yes		
No	174	86	260	17%
Yes	253	1041	1294	83%
Total	427	1127	1554	100%
Percentage	27%	73%	100%	0%

Table 86 shows that the most commonly occurring group of crashes (49 percent, 761/1554) were those on roadways with posted speed limits of 30 mph or 35 mph; however, posted speed limit could not be identified for 12 percent of the crash locations (181/1554). As shown in Table 87, most crashes (60 percent, 943/1554) occurred at either an intersection or a driveway; almost all driveway locations had no traffic control device. Eighteen percent (174/943) of the intersection/driveway locations had skewed geometry (i.e., not intersecting at 90 degrees).

Table 84 shows that crashes most commonly (513/1554) occurred on two-lane roads with no left turn lanes. Correspondingly, as shown in Table 85, most crashes (61 percent, 949/1554) occurred on roadways with no median, followed by roadways with two-way left-turn lanes (14 percent, 224/1554). Figure 31 shows that on these roadways, the median width ranged from 0 to 389 feet, with most crashes occurring on roadways with less than a 50 foot median. Figure 32 shows that the crossing width to refuge ranged from 10 to 186 feet, with crossing distance increasing with the total number of lanes.

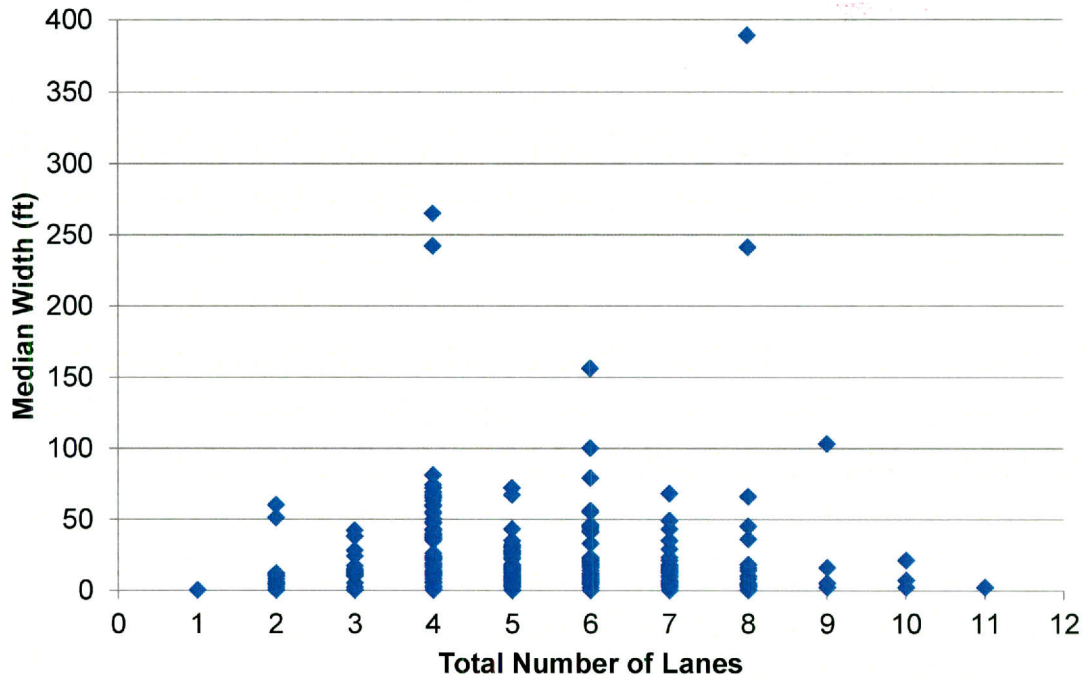
Table 86 shows that the most commonly occurring group of crashes (49 percent, 761/1554) were those on roadways with posted speed limits of 30 mph or 35 mph; however, posted speed limit could not be identified for 12 percent of the crash locations (181/1554). As shown in Table 87, most crashes (60 percent, 943/1554) occurred at either an intersection or a driveway; almost all driveway locations had no traffic control device. Eighteen percent (174/943) of the intersection/driveway locations had skewed geometry (i.e., not intersecting at 90 degrees).

**Table 84. Distribution of 2011 TxDOT-Reportable Fatal and Injury Crashes in Select TxDOT Districts by Total Number of Lanes and Number of Left-Turn Lanes.**

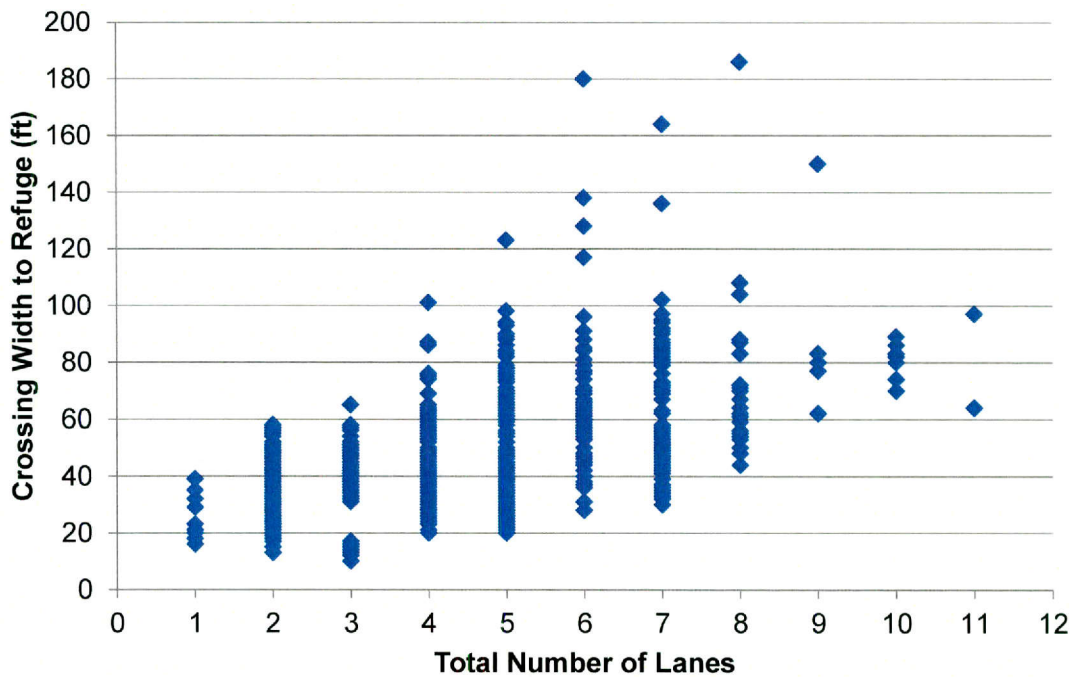
Main: Total Number of Lanes	Main: Number of Left-Turn Lanes			Total	Percentage
	0	1	2		
1	13	1	0	14	1%
2	513	2	0	515	33%
3	30	54	0	84	5%
4	289	15	0	304	20%
5	21	335	2	358	23%
6	60	34	20	114	7%
7	9	102	7	118	8%
8	15	9	6	30	2%
9	5	0	2	7	0%
10	6	0	2	8	1%
11	2	0	0	2	0%
Total	963	552	39	1554	100%
Percentage	62%	36%	3%	100%	

**Table 85. Distribution of 2011 TxDOT-Reportable Fatal and Injury Crashes in Select TxDOT Districts by Median Type and Median Width.**

Main: Median Width (ft)	Barrier	Divided	Flush	None	Raised	TWLTL	Total	Percentage
0	0	0	0	948	0	0	948	61%
2-6	49	0	23	1	98	7	178	11%
7-12	5	0	12	0	51	104	172	11%
13-24	17	4	10	0	32	113	176	11%
25-36	6	4	1	0	10	0	21	1%
37+	22	26	0	0	11	0	59	4%
Total	99	34	46	949	202	224	1554	100%
Percentage	6%	2%	3%	61%	13%	14%	100%	0%



**Figure 31. Distribution of 2011 TxDOT-Reportable Fatal and Injury Crashes in Select TxDOT Districts by Median Width (ft) and Total Number of Lanes.**



**Figure 32. Distribution of 2011 TxDOT-Reportable Fatal and Injury Crashes in Select TxDOT Districts by Crossing Width to Refuge (ft) and Total Number of Lanes.**

**Table 86. Distribution of 2011 TxDOT-Reportable Fatal and Injury Crashes in Select TxDOT Districts by Posted Speed Limit (mph) and Total Number of Lanes.**

Main: Posted Speed Limit (mph)	Main: Total Number of Lanes					Total	Percentage
	1	2	3	4	5+		
10	0	1	0	0	0	1	0%
15	0	12	1	0	0	13	1%
20	0	41	3	17	16	77	5%
25	1	13	1	1	1	17	1%
30	4	282	39	74	50	449	29%
35	1	27	21	103	160	312	20%
40	0	10	4	31	152	197	13%
45	2	15	2	9	110	138	9%
50	0	8	2	2	15	27	2%
55	0	6	1	4	16	27	2%
60	0	12	0	8	36	56	4%
65	0	4	0	10	24	38	2%
70	0	2	0	10	7	19	1%
75	0	0	0	2	0	2	0%
Not Found	6	82	10	33	50	181	12%
Total	14	515	84	304	637	1554	100%
Percentage	1%	33%	5%	20%	41%	100%	

**Table 87. Distribution of 2011 TxDOT-Reportable Fatal and Injury Crashes in Select TxDOT Districts By Crash Location and Traffic Control Type.**

Crash Location	Traffic Control Type				Total	Percentage
	Beacon	No Control	Traffic Signal	Stop Controlled		
Driveway	0	95	1	3	99	6%
Intersection	3	11	409	421	844	54%
Midblock	0	611	0	0	611	39%
Total	3	717	410	424	1554	100%
Percentage	0%	46%	26%	27%	100%	

### **Pedestrian Characteristics**

A total of 88,127 person records were available for the 34,620 crashes identified as TxDOT-reportable pedestrian crashes in the CRIS database. To identify pedestrians in the person files provided in CRIS, the person occupant position (POP) and person type (PT) variables were used. POP 16 represents pedestrian, pedalcyclist, or motorized conveyance. PT 4 represents pedestrian. Among the 88,127 records, 36,530 had POP 16; 23,498 records had PT 4; and 23,497 records had POP 16 and PT 4. For this analysis, a record with POP 16 and PT 4 was considered as a pedestrian (23,497 records), and a record with PT 1 or PT 5 was considered as a driver (39,197 records).

Table 88 shows the distribution of crash records (by injury severity) by POP, and Table 89 shows the distribution of crash records by PT. As shown in the tables, in pedestrian-related crashes a very high proportion of pedestrians are either killed or seriously injured, whereas most drivers or passengers are not injured, as would be expected.

**Table 88. Number of TxDOT-Reportable Pedestrian Crash Records by Person Occupant Position.**

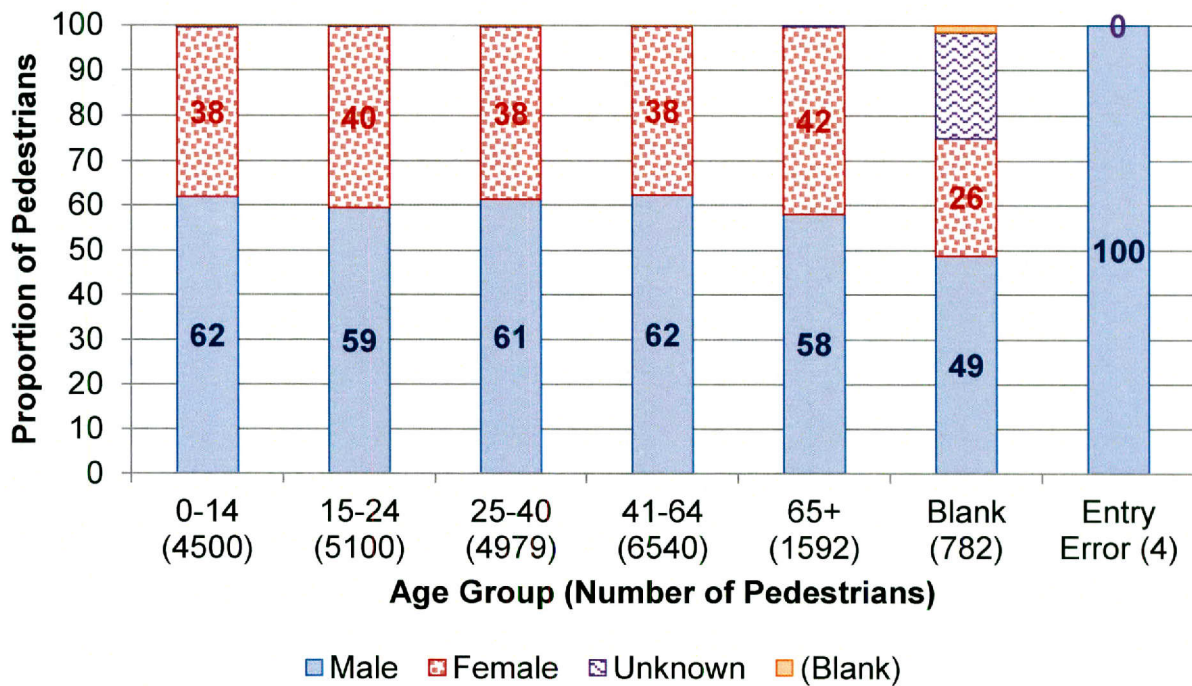
Person Occupant Position Code	Person Occupant Position Description	Injury Severity							Total Number of Records
		Unknown	Incapacitating Injury	Non-incapacitating Injury	Possible Injury	Killed	Not Injured	Blank	
1	Front left	7179	203	720	1009	22	27431	269	36833
2	Front center	6	7	14	21		208	2	258
3	Front right	178	29	121	221	6	5557	7	6119
4	Second seat left	17	9	32	50	1	1761	1	1871
5	Second seat center	7	3	23	32	1	881		947
6	Second seat right	24	11	36	55		2080	2	2208
7	Third seat left	1	1	1	4		108		115
8	Third seat center				2		46		48
9	Third seat right			1	2		94		97
10	Cargo area	1	2	8	3		41		55
11	Outside vehicle	2	4	8	3		20		37
12	Unknown	245	4	11	8		144	9	421
13	Other in vehicle	6	1		3		65		75
14	Passenger in bus	124		9	42		1030	1	1206
15	Not in vehicle	908	19	51	41	2	5		1026
16	Pedestrian, pedalcyclist, or motorized conveyance	758	5990	14306	11755	2255	1441	25	36530
98	Other (explain in narrative)		4	7	3		9		23
Blank	Blank	200	1		1		14	42	258
	<b>Total</b>	9656	6288	15348	13255	2287	40935	358	88127

**Table 89. Number of TxDOT-Reportable Pedestrian Crash Records by Person Type.**

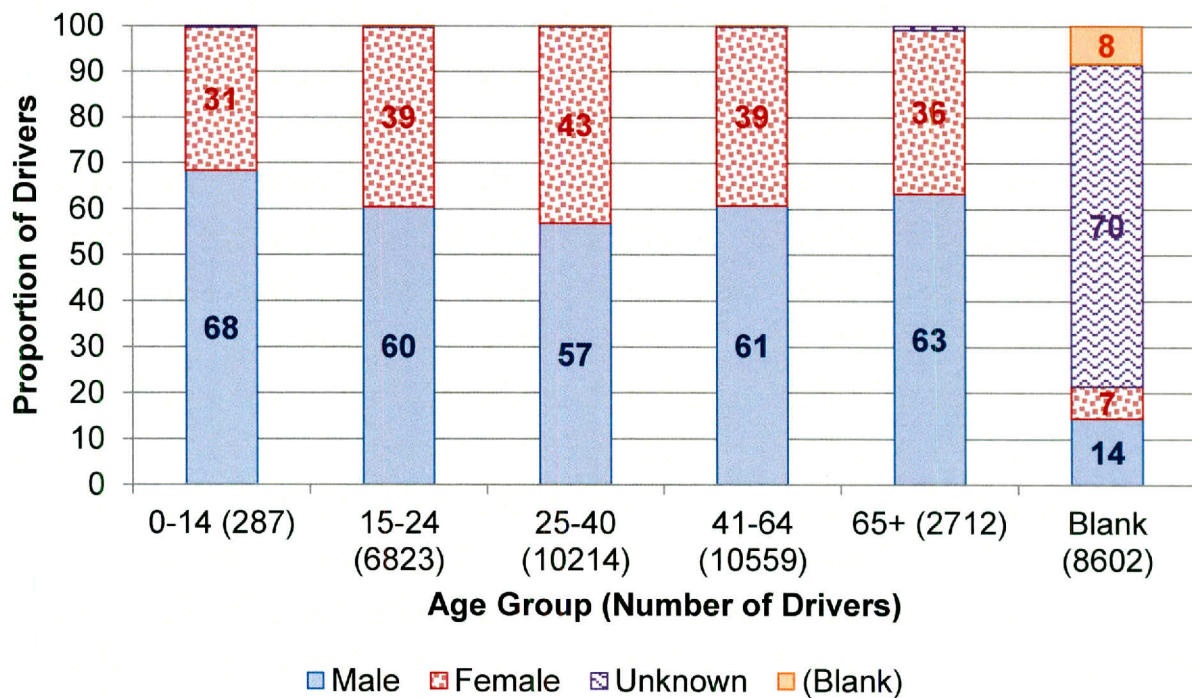
Person Type Code	Person Type Description	Injury Severity							Total Number of Records
		Unknown	Incapacitating Injury	Non-incapacitating Injury	Possible Injury	Killed	Not Injured	Blank	
1	Driver	7789	245	808	1146	28	27562	313	37891
2	Passenger/Occupant	423	86	308	496	13	12188	18	13532
3	Pedalcyclist	115	1250	4857	3698	240	357	8	10525
4	Pedestrian	252	4448	8717	7507	1981	579	14	23498
5	Driver Of Motorcycle Type Vehicle	78	192	524	294	16	201	1	1306
6	Passenger/Occupant On Motorcycle Type Vehicle	2	17	35	21		21	1	97
10	Motorized Conveyance	1	13	27	26	2	1		70
95	Not reported	1	1	2	2				6
97	Not applicable	2	1	6	1				10
98	Other (Explain In Narrative)	6	26	37	43	6	17		135
99	Unknown	96	9	27	21	1	9	3	166
99999	Internal (Charge Person Name No Match)	891							891
	<b>Total</b>	9656	6288	15348	13255	2287	40935	358	88127

Figure 33 shows the distribution of age group and gender among pedestrians and drivers involved in pedestrian-related crashes. As shown in the figure, most (6540/23,497 or 28 percent) pedestrians involved in the crashes and most (10,559/39,197 or 27 percent) drivers involved in the crashes were in the age group 41–64 years. Also, overall a higher proportion of male pedestrians (61 percent) and drivers (50 percent; 16 percent drivers had unknown gender coded in the database) were involved in pedestrian-related crashes than females.

Figure 34 shows a distribution of ethnicity among pedestrians and drivers involved in crashes. The database did not have ethnicity information (i.e., blank or unknown) for 62.5 percent of the pedestrians and 16 percent of the drivers. Pedestrians and drivers involved in pedestrian-related crashes were mainly either of white or Hispanic ethnicities.

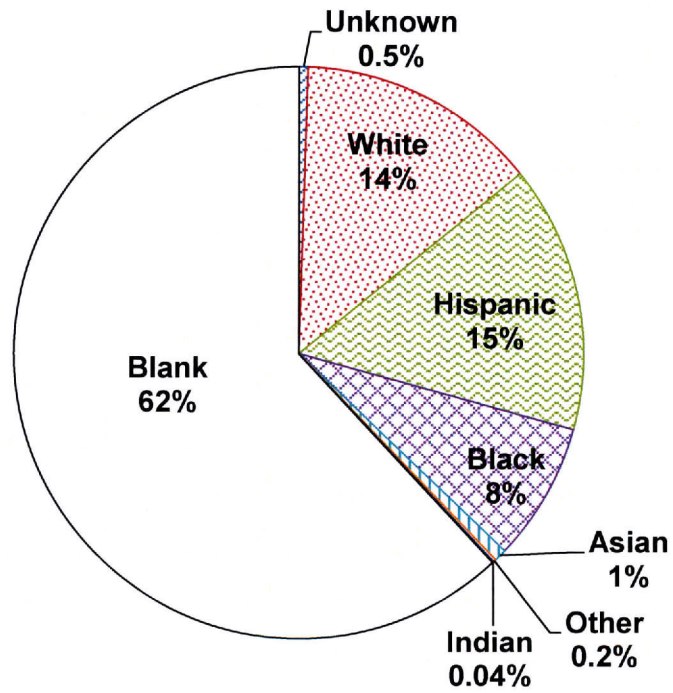


a) Pedestrians

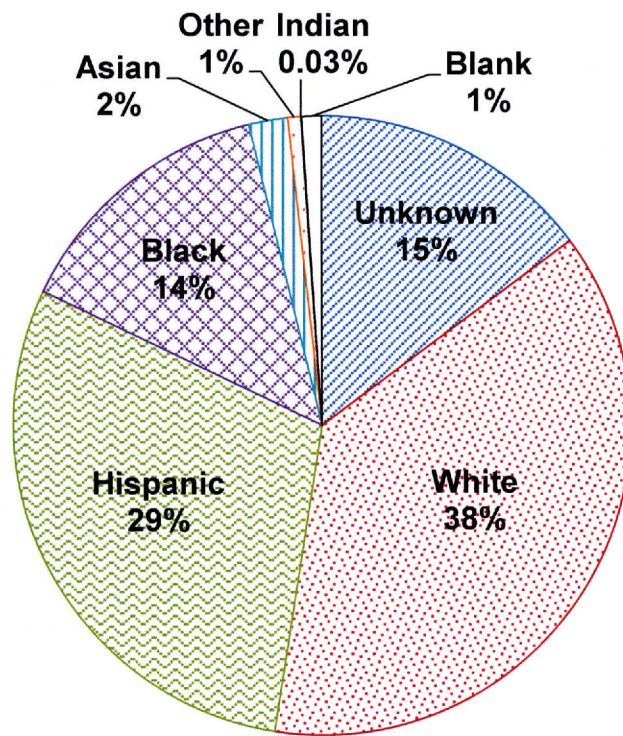


b) Drivers

Figure 33. Age Group Distribution by Gender in TxDOT-Reportable Pedestrian Crashes (2007–2011).



a) Pedestrians



b) Drivers

Figure 34. Ethnicity Distribution in TxDOT-Reportable Pedestrian Crashes (2007–2011).



Table 90 shows a distribution of alcohol test results of pedestrians and drivers involved in pedestrian crashes. Alcohol test result information was not recorded for 98 percent of the pedestrians (22,916/23,497) and 98 percent of the drivers (38,491/39,197). Among those with records, there were more pedestrians that tested positive than drivers.

**Table 90. Alcohol Test Result of Drivers and Pedestrians Involved in TxDOT-Reportable Pedestrian Crashes (2007–2011).**

Alcohol Result	Driver	Pedestrian	% Driver	% Pedestrian	% of Drivers with Alcohol Results	% of Pedestrians with Alcohol Results
Positive	364	362	1%	2%	52%	62%
Negative	342	219	1%	1%	48%	38%
Blank	38491	22916	98%	98%		
<b>Total</b>	<b>39197</b>	<b>23497</b>	<b>100%</b>	<b>100%</b>		

## DISCUSSION

The Texas data showed that 2 percent of all traffic crashes were pedestrian related, whereas 15 percent of all fatal traffic crashes were pedestrian related. TxDOT Houston District had the largest overall number of crashes with 8130 pedestrian crashes with approximately 14 percent of these being fatal. Dallas, San Antonio, Austin, and Fort Worth also had a high number of pedestrian crashes, which is expected since they are the most urbanized locations in the state. Serious injury and fatal pedestrian crashes ranged from 18 percent (in Laredo and El Paso) to 64 percent (in Childress) of the total pedestrian crashes per TxDOT district. Yoakum District had the most decrease and Childress District had the most increase in all pedestrian crashes in 2011 when compared to 2007. Also, Wichita Falls District saw the most decrease and Lufkin District saw the most increase in fatal pedestrian crashes in 2011 when compared to 2007.

Approximately 85 percent of all pedestrian crashes and 70 percent of all fatal pedestrian crashes were at non-rural locations. This could be an indication of lower exposure and volume in terms of fewer pedestrians on rural roads. Approximately 47 percent of the available pedestrian crash data were found to be non-intersection related, and approximately 53 percent were either at an intersection/driveway or related to the intersection. Also, 89 percent of the pedestrian crashes were found to have occurred on the roadway, while 2 percent occurred on the shoulder and 0.2 percent on the median. Most pedestrian crashes were observed at locations with no traffic control device, followed by locations with a traffic signal. Eighty-five percent of pedestrian crashes in a no-passing zone occurred at rural locations, whereas for all other traffic control device categories, a higher proportion of crashes were in urban settings. This could also be an indication of the fact that no-passing zones are more common in rural locations.

The data showed that most pedestrian crashes occurred during daylight and that fatal pedestrian crashes were more common in the “dark, not lighted” conditions. Through the day, three peaks were observed for pedestrian crashes. AB and C types of crashes peak in the PM peak hour (5–6 p.m.), while K type of crashes peak at 9 p.m. The other two peaks were at 7 a.m. and 2 a.m. Also, October was observed to be the month with the highest number of pedestrian crashes. Overall, most pedestrian crashes occurred in clear/cloudy conditions.

As can be expected in pedestrian-related crashes, a very high proportion of pedestrians were either killed or seriously injured, whereas most drivers or passengers involved in the crash were not injured. Most of the pedestrians (28 percent) involved in the crashes and most of the drivers (27 percent) involved in the crashes were in the age group 41–64 years. Overall, a higher proportion of male pedestrians and drivers were involved in pedestrian-related crashes than females. The CRIS database did not have ethnicity information (i.e., blank or unknown) for 62.5 percent of the pedestrians and 16 percent of the drivers. Pedestrians and drivers involved in pedestrian-related crashes were mainly either of white or Hispanic ethnicities. Alcohol test result information was not recorded for 98 percent of the pedestrians (22,916/23,497). Among those with records, there were more pedestrians that tested positive than drivers.

Review of geometric characteristics (identified from aerial photographs) for 1,554 TxDOT reportable injury and fatal pedestrian crashes that occurred in Austin, Bryan, Corpus Christi, Laredo, and San Antonio TxDOT Districts in 2011 also showed that a higher proportion of the injury crashes occurred on arterials, whereas equal proportions of fatal crashes occurred on arterials and freeways. Most of the crashes (78 percent, 1208/1554) occurred on roadways without on-street parking and 67 percent (1041/1554) occurred at locations with roadway lighting and sidewalks. Such locations provide better conditions for pedestrians; however, the high proportion of crashes could be a reflection of the proportion of roadways with lighting and sidewalks in the system. In terms of the number of lanes on the roadway, a plurality (33 percent, 513/1554) of crashes were on two-lane roads with no left turn lanes, followed by five-lane roads with a left turn lane (335/1554). The median width ranged from 0 to 389 feet, with most crashes occurring on roadways with less than a 50-ft median. The crossing width to refuge ranged from 10 to 186 feet, with the crossing distance increasing with the total number of lanes. Relative to speed limit, the largest number of crashes (49 percent, 761/1554) occurred on roadways with posted speed limits of 30 mph or 35 mph; however, the posted speed limit could not be identified for 12 percent of the crash locations (181/1554). Most crashes (60 percent, 943/1554) occurred at either an intersection or a driveway; almost all driveway locations had no traffic control device. Eighteen percent (174/943) of the intersection/driveway locations had skewed geometry (i.e., not intersecting at 90 degrees).

## **SUMMARY**

This research effort provided an understanding of Texas pedestrian crashes from an exploratory analysis of 34,620 TxDOT-reportable pedestrian crashes (identified from the TxDOT CRIS data set for 2007–2011). Various crash and person characteristics are discussed, such as 85 percent of crashes occurred at urban locations, 61 percent of crashes occurred in daylight, and 28 percent of the pedestrians were in the age group 41–64 years. Additional geometric information was collected at the 2011 fatal and injury pedestrian crash locations in Austin, Bryan, Corpus Christi, Laredo, and San Antonio TxDOT Districts. Findings from that review are also discussed.

## CHAPTER 10

### IN-DEPTH REVIEW OF TEXAS FATAL PEDESTRIAN CRASHES

#### BACKGROUND

Researchers explored the TxDOT Crash Record Information System database to identify characteristics of fatal pedestrian crashes from 2007 to 2011. A total of 2359 fatal pedestrian crashes were identified between those years. Of these crashes, 2232 (95 percent) were coded as TxDOT reportable. Table 91 shows the distribution of fatal pedestrian crashes by TxDOT reportability and year. As shown in the table, overall 15 percent of TxDOT-reportable fatalities involved a pedestrian. On the other hand, 64 percent of crashes that are not TxDOT reportable were coded as pedestrian related. This analysis will focus only on TxDOT-reportable crashes. Also, TxDOT-reportable pedestrian fatal crashes as a percentage of all fatal crashes have increased from 14 percent in 2009 and 2010 to 17 percent in 2011. Nationally, pedestrian fatalities increased in 2010 when compared to 2009, from 12 percent to 13 percent (175).

**Table 91. Fatal Crashes by Year and TxDOT-Reportable Flag (2007–2011).**

Year	Not TxDOT Reportable			TxDOT Reportable		
	All Fatal Crashes	Pedestrian Fatal Crashes	Pedestrian Fatal Crashes as a Percentage of All Fatal Crashes	All Fatal Crashes	Pedestrian Fatal Crashes	Pedestrian Fatal Crashes as a Percentage of All Fatal Crashes
2007	44	29	66%	3101	480	15%
2008	34	22	65%	3126	489	16%
2009	35	26	74%	2817	402	14%
2010	35	17	49%	2752	397	14%
2011	52	33	63%	2744	464	17%
<b>Sum</b>	<b>200</b>	<b>127</b>	<b>64%</b>	<b>14,540</b>	<b>2,232</b>	<b>15%</b>

Figure 35 shows a distribution of fatal crashes by year and source type (Fatality Analysis Reporting System vs. CRIS). As shown in the figure, TxDOT-reportable fatal pedestrian crash numbers from the CRIS database are higher than from FARS. Several reasons could contribute to the difference, such as the methodology to identify fatal crashes in this study (the research team used the person and unit variables in addition to the crash variables to identify pedestrian crashes). The variation between the FARS and CRIS databases is similar across the years. Table 92 shows the numbers of records by harmful event (a variable in the crash files used in data set assembly for this analysis). The majority of the records (79 percent) were identified using the harmful event variable code of 1 (i.e., pedestrian). The remaining records (21 percent) were identified using variables/codes from the person and unit files, which accounts for the about 100 crash difference between the two databases.

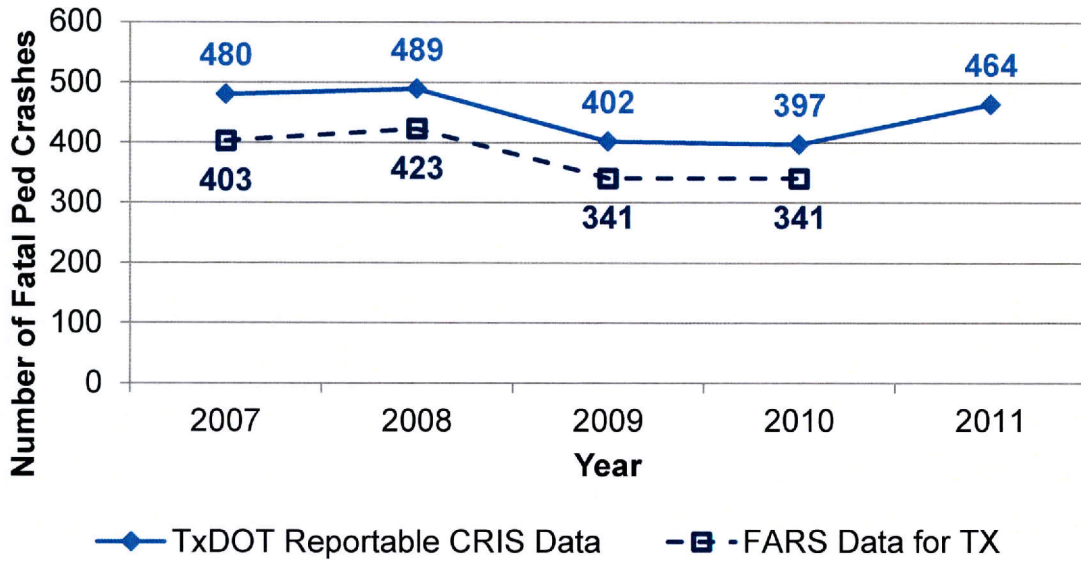


Figure 35. Comparison of CRIS and FARS Data for Fatal Pedestrian Crashes (2007–2011).

Table 92. Number of Fatal Pedestrian TxDOT-Reportable Crash Records by Harmful Event Code.

Number of Records	Percent of Total	Harmful Event Code	
		Code	Description
1,774	79	1	Pedestrian
106	5	2	Motor Vehicle in Transport
1	0.04	3	RR Train
48	2	4	Parked Car
235	11	5	Pedalcyclist
45	2	7	Fixed Object
14	1	8	Other Object
5	0.2	9	Other Non-Collision
4	0.2	10	Overtaken
<b>2,232</b>	<b>100</b>		

### DATA ASSEMBLY

Data used in this analysis were derived from the data set described in Chapter 9 (in-depth review of Texas pedestrian crashes). Fatal crashes in the database were identified using the “crash severity” variable. All crash IDs with crash severity of 4 (i.e., fatal) were identified and the crash, person, and unit properties associated with these crash IDs extracted.

## EXPLORATORY ANALYSIS

### Crash Characteristics

Variables available from the crash files were explored to better understand Texas fatal pedestrian crashes. The manner of collision for 1981 of the 2232 fatal pedestrian crashes (i.e., 89 percent) was coded as multi-vehicle collision with the vehicle involved going straight (as shown in Table 93). The second most common collision manner coded was multi-vehicle collision with a vehicle turning left (3 percent). The object struck field was not applicable for 91 percent of the crashes, and the next most common object struck was a previously wrecked vehicle for 1 percent (28/2232) of the crashes. Also, 85 percent of the 2232 crashes did not have any additional detail of events/circumstances concerning the crash; however, 3 percent of the crashes occurred on roadways with construction.

**Table 93. Number of Fatal Crash Records by Manner of Collision.**

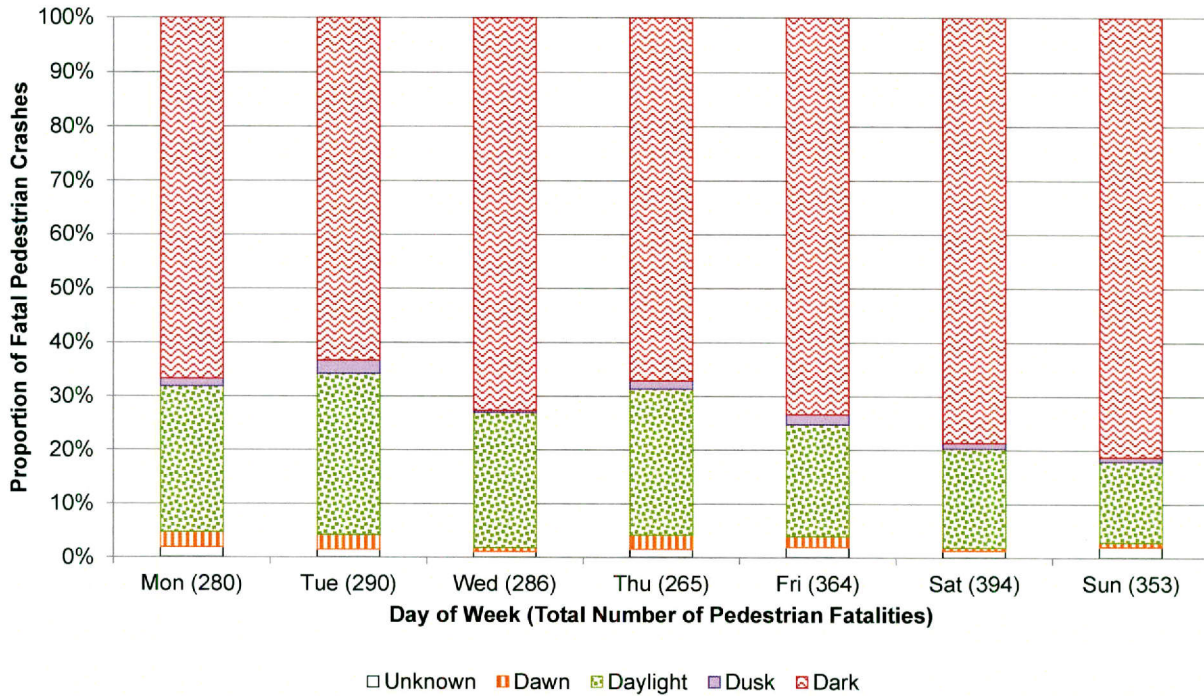
<b>Manner of Collision</b>	<b>Number of Fatal TxDOT-Reportable Pedestrian Crashes</b>	<b>Percentage of Total</b>
OMV vehicle going straight	1981	89%
OMV vehicle turning left	69	3%
SD one straight-one stopped	40	2%
OMV vehicle turning right	39	2%
OMV vehicle backing	29	1%
Angle – both going straight	15	1%
SD both going straight-sideswipe	14	1%
SD both going straight-rear end	10	0%
OMV other	8	0%
OD one straight-one left turn	7	0%
Angle – one straight-one stopped	6	0%
SD one straight-one left turn	4	0%
OD one straight-one stopped	4	0%
Angle – one straight-one left turn	3	0%
OD both going straight	3	0%
<b>Total</b>	<b>2232</b>	<b>100%</b>
*OMV = Other Multi Vehicle SD = Same Direction OD = Opposite Direction		

Table 94 shows the distribution of fatal pedestrian crashes by weather and light conditions. As shown in the table, most crashes occurred in clear or cloudy conditions (93 percent). Nationally, 88 percent of pedestrian fatalities occur in clear or cloudy conditions (175). Also, the most commonly occurring group of crashes occurred in “dark, not lighted” (39 percent) followed by “dark, lighted” (32 percent). Overall, more crashes occurred in dark conditions than in daylight (73 percent). Nationally, 68 percent of pedestrian fatalities occur in nighttime conditions (175).

**Table 94. Number of Fatal Crash Records by Weather Condition and Light Condition.**

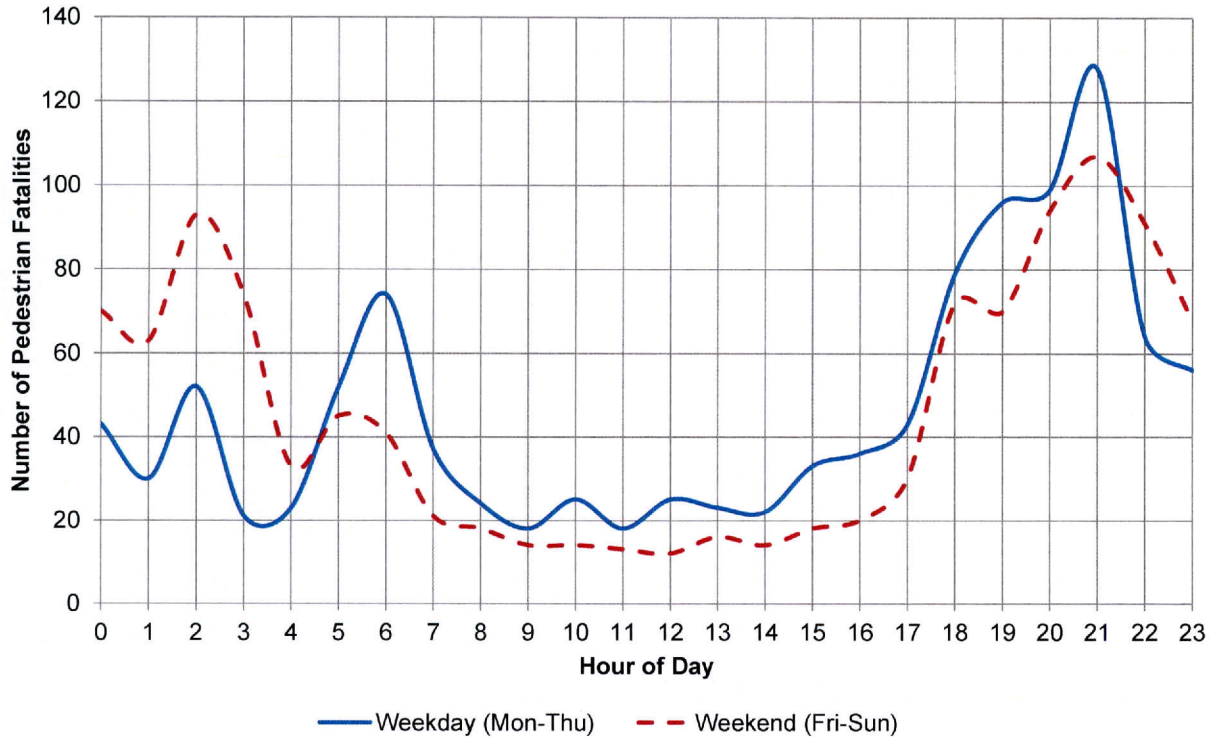
<b>Weather Condition/ Light Condition</b>	<b>Unknown</b>	<b>Daylight</b>	<b>Dawn</b>	<b>Dusk</b>	<b>Dark, Not Lighted</b>	<b>Dark, Lighted</b>	<b>Dark, Unknown Lighting</b>	<b>Blank</b>	<b>Total</b>
Unknown	8	1			3				12
Clear/Cloudy	7	309	21	17	495	382	27	15	1273
Rain		11		2	47	49	6		115
Sleet/Hail		2				3			5
Snow					1	1			2
Fog			2		8	3			13
Blowing Sand/Snow		1				2			3
Other (Explained in narrative)		1				2			3
Clear		160	13	11	265	225	9		683
Cloudy	1	23	1		48	43			116
Blank		1				2		4	7
<b>Total</b>	<b>16</b>	<b>509</b>	<b>37</b>	<b>30</b>	<b>867</b>	<b>712</b>	<b>42</b>	<b>19</b>	<b>2232</b>
<b>Percent</b>	<b>1%</b>	<b>23%</b>	<b>2%</b>	<b>1%</b>	<b>39%</b>	<b>32%</b>	<b>2%</b>	<b>1%</b>	
<b>Percent by Day or Night</b>	<b>1%</b>	<b>23%</b>	<b>3%</b>		<b>73%</b>			<b>1%</b>	

Figure 36 shows the distribution of pedestrian fatal crashes by the day of week and light condition. As shown in the figure, the highest number of crashes occurred on a Saturday (393 crashes), followed by Friday and Sunday. Only 1121 pedestrian fatalities occurred on weekdays (Mon–Thu), whereas 1111 or 50 percent of pedestrian fatalities occurred over a weekend (Fri–Sun), which is similar to the national statistic of 48 percent (175). Also, as seen in the figure, more dark condition crashes are observed on weekend days when compared to weekdays.

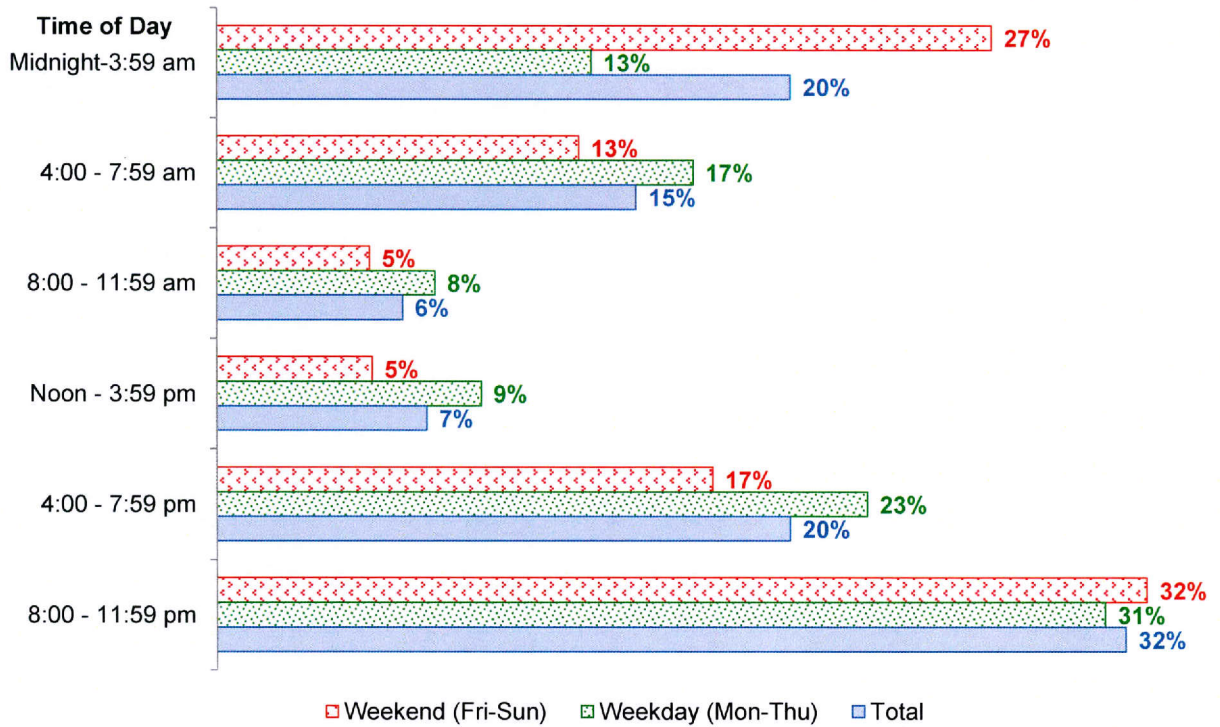


**Figure 36. Fatal Pedestrian Crashes by Day of Week and Light Condition (2007–2011).**

Figure 37 shows the trend of pedestrian fatalities by the hour of the day and day of the week. The night peak period for weekday and weekend was similar (i.e., between 8 p.m. and 10 p.m.), whereas the late night and early morning peaks for the two were reversed. In other words, the early morning peak (6 a.m.) was higher than the late night peak (2 a.m.) for weekdays, whereas for weekend the late night peak (2 a.m.) was higher than the early morning peak (5 a.m.). Figure 37b also shows a higher proportion of pedestrian fatalities in the late night/early morning time for weekends when compared to weekdays. Overall, 32 percent of pedestrian fatalities occur in the 8 p.m.–11:59 p.m. time of the day, which is close to the national statistic of 30 percent (175). This could be a reflection of higher late-night traffic on weekends when compared to weekdays.



a) By Hour of Day

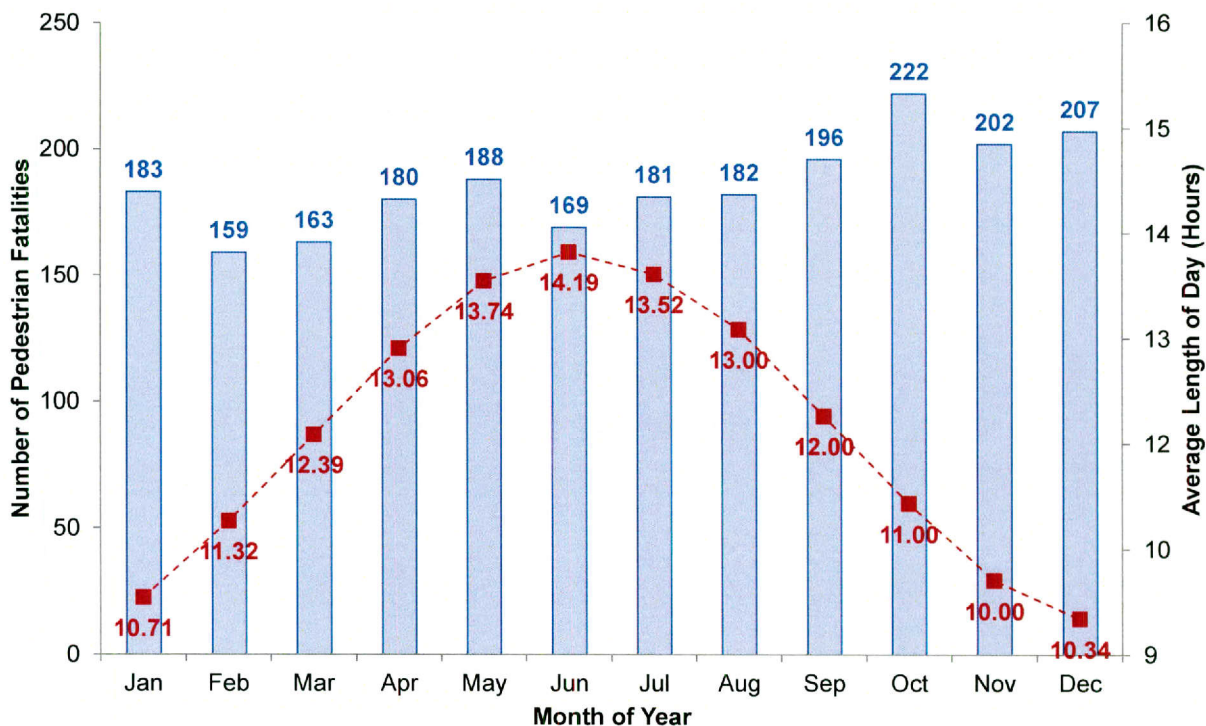


b) By Time of Day

**Figure 37. Fatal Pedestrian Crashes by Hour of Day and Day of Week (2007–2011).**

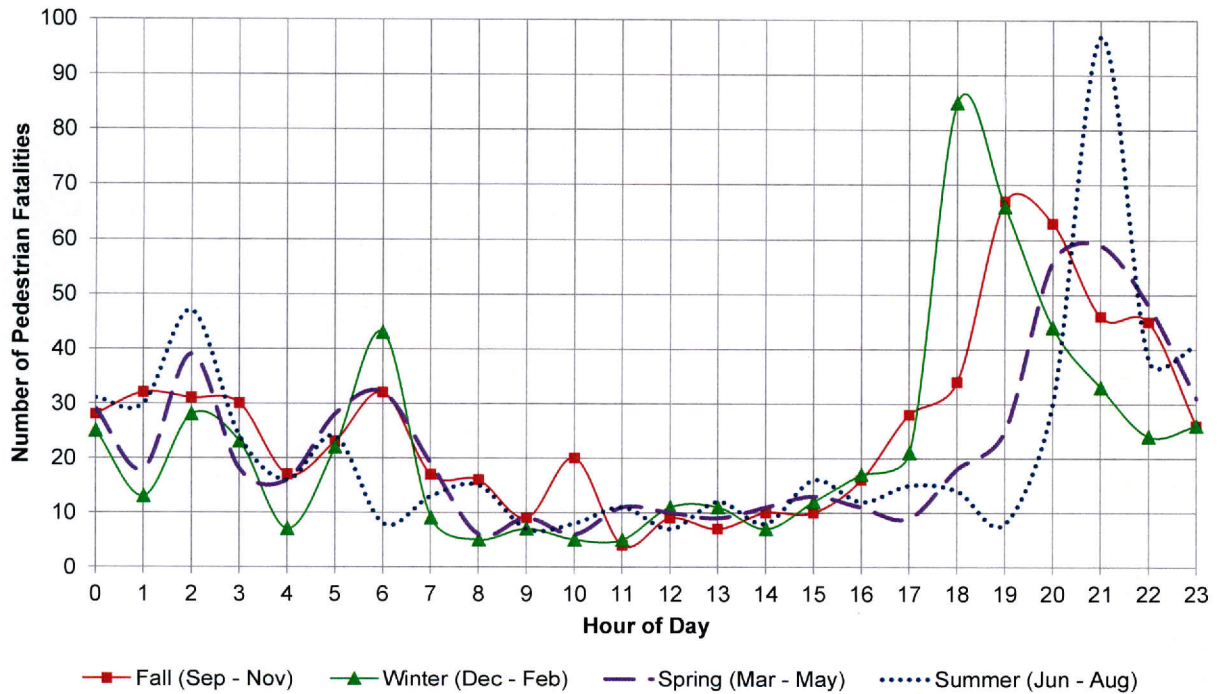


Figure 38 shows the distribution of pedestrian fatal crashes and the average length of the day (corresponding to central daylight time) by the month of the year. As shown in the figure, the highest number of crashes occurred in October (222 crashes), followed by December and November. There does not seem to be an obvious relation with the length of the day and number of crashes.



**Figure 38. Fatal Pedestrian Crashes by Month of Year (2007–2011).**

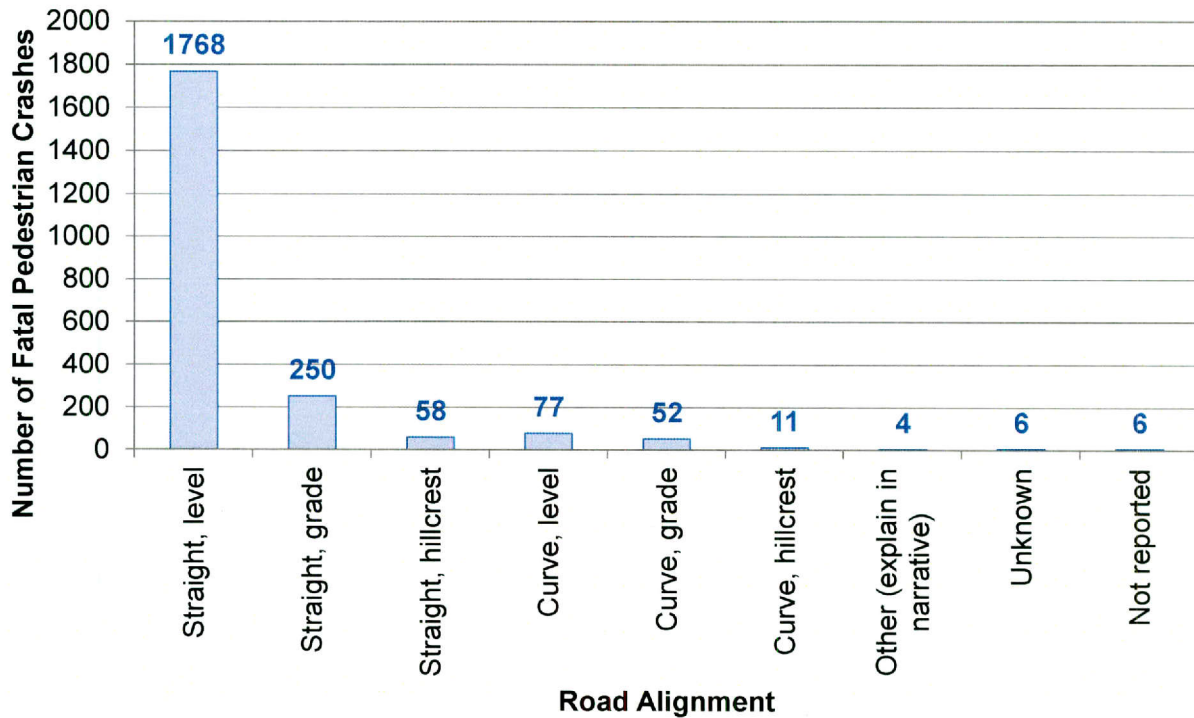
Figure 39 shows the trend of pedestrian fatalities by the hour of day and season/month of the year. The late night and early morning peaks for all four seasons are similar (i.e., between 8 p.m. and 10 p.m.), whereas the night peaks are staggered across the four seasons, with the winter peak at 6 p.m. and summer peak being at 9 p.m. This could be a reflection of the change in sunset times across these seasons and the issues related to dusk.



**Figure 39. Fatal Pedestrian Crashes by Hour of Day and Season/Month of Year (2007–2011).**

### Roadway Characteristics

CRIS files have a number of variables that describe the roadway characteristics at the crash location. Some of these variables are explored in this section. As shown in Figure 40, most fatal pedestrian crashes (79 percent) occurred on straight, level roads. It is expected that pedestrian crash characteristics vary with the location of the crash, especially in relation to an intersection. In the database assembled for this analysis, more crashes were observed at non-intersection locations (1722/2232 or 87 percent) and on roadways (2005/2232 or 90 percent), as shown in Table 95. Nationally, 79 percent of the pedestrian fatal crashes occur at non-intersection locations (175).

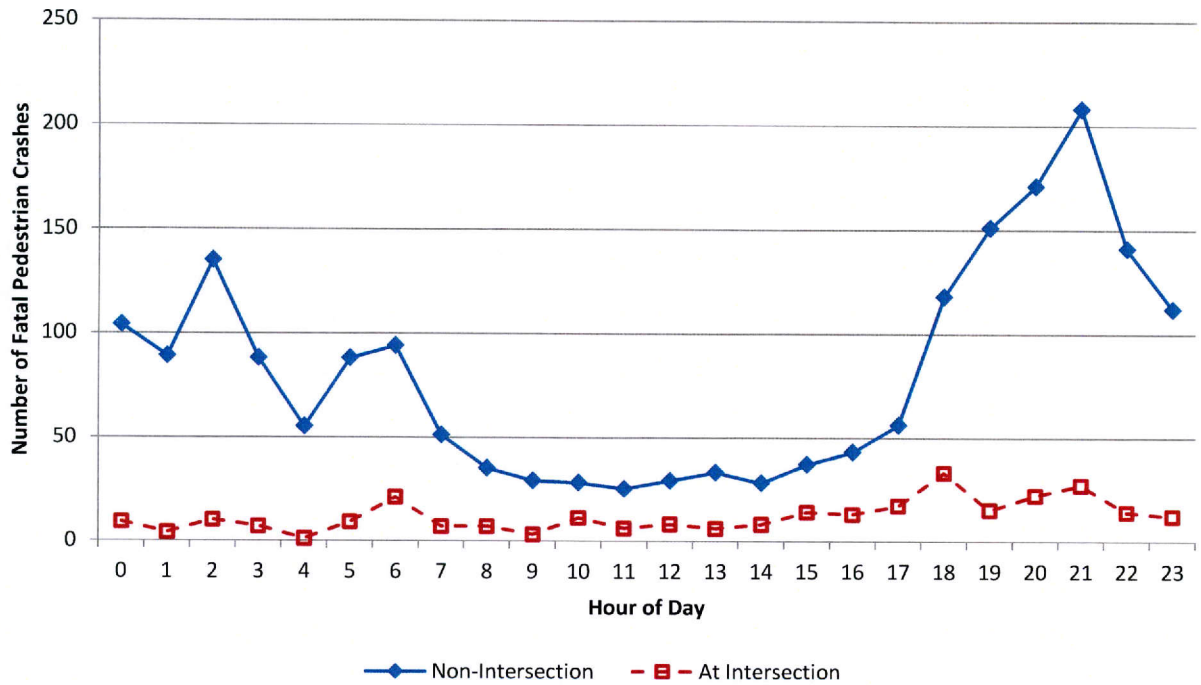


**Figure 40. Fatal Pedestrian Crashes by Road Alignment (2007–2011).**

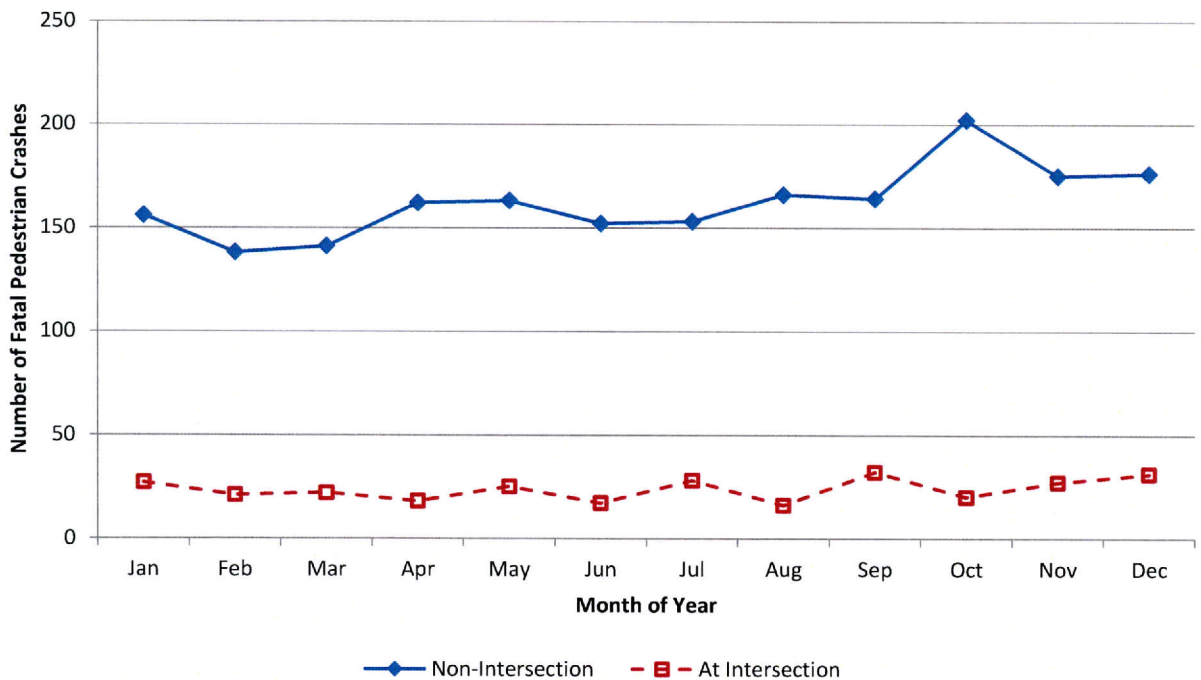
**Table 95. Fatal Pedestrian Crashes by Roadway and Intersection Relation.**

Road Relation/ Intersection Relation	Intersection	Intersection Related	Driveway Access	Non- Intersection	Total
On Roadway	159	272	46	1528	<b>2005</b>
Off Roadway		10	7	87	<b>104</b>
Shoulder	1	7		94	<b>102</b>
Median		3		4	<b>7</b>
Not Applicable			2	2	<b>4</b>
Not Reported		3		7	<b>10</b>
<b>Total</b>	<b>160</b>	<b>295</b>	<b>55</b>	<b>1722</b>	<b>2232</b>

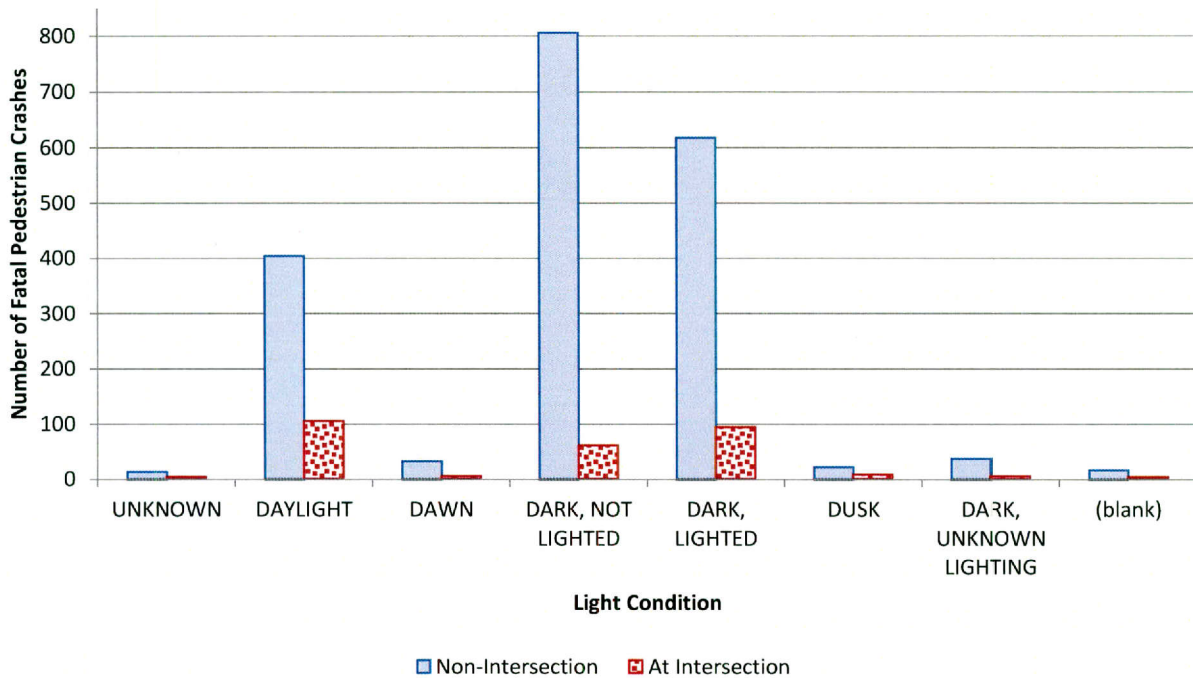
Figure 41 shows the distribution of fatal crashes over the hour of the day by relation to intersection, and Figure 42 shows the distribution of fatal crashes over the month of the year by relation to intersection. As shown in Figure 41, fatal pedestrian crash numbers were considerably higher in the night hours; the numbers peaked at dawn and dusk for crashes at intersections (6 a.m. and 6 p.m.), whereas for crashes at non-intersection locations, the peaks were at late-night and early-morning hours (2 a.m. and 9 p.m.). The non-intersection at nighttime crashes may deserve additional investigation. As shown in Figure 42, non-intersection crashes peaked in October, whereas crashes at intersections peaked in September. Figure 43 shows the distribution of fatal pedestrian crashes by light condition and relation to intersection. As shown in the figure, most non-intersection crashes occurred under the dark, not lighted conditions (41 percent) followed by dark, lighted conditions (32 percent), whereas most intersection crashes occurred in the daylight condition (37 percent), followed by dark, lighted conditions (33 percent).



**Figure 41. Fatal Pedestrian Crashes by the Hour of Day and Intersection Relation (2007–2011).**



**Figure 42. Fatal Pedestrian Crashes by Month of Year and Intersection Relation (2007–2011).**

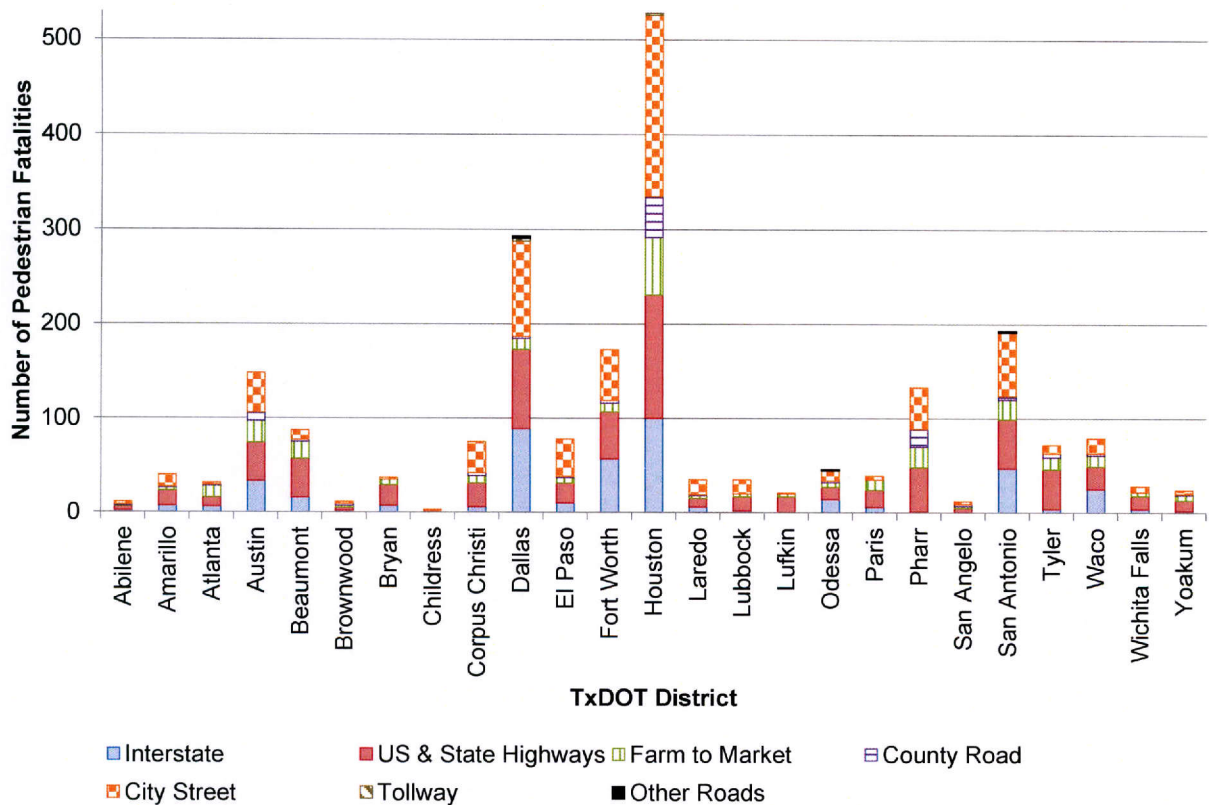


**Figure 43. Fatal Pedestrian Crashes by Light Condition and Intersection Relation (2007–2011).**

Most of the 2232 fatal pedestrian crashes occurred in non-rural areas (1558 or 70 percent) and on TxDOT system roadways (1512 or 68 percent). Nationally, 73 percent of pedestrian fatalities occur in urban areas (175). In Texas, 52 percent of the fatal crashes were recorded to be on Interstate or U.S. and State highways (1163/2232), and as shown in Table 96, they were mostly on the main lanes (2005 or 90 percent). As shown in Figure 44, TxDOT districts with larger cities have more fatal pedestrian crashes.

**Table 96. Fatal Pedestrian Crashes by Road Class and Road Part.**

Road Class/ Lane Type	Main/ Proper Lane	Service/ Frontage Road	Entrance/ On Ramp	Exit/Off Ramp	Connector/ Flyover	Detour	Not Reported	Total
Interstate	335	71	12	12	1	15		446
U.S. & State Highways	638	37	12	10	3	16	1	717
Farm to Market	263	1				2		266
County Road	100					3		103
City Street	663	6	2			17	3	691
Tollway	5							5
Other Roads	1					3		4
<b>Total</b>	<b>2005</b>	<b>115</b>	<b>26</b>	<b>22</b>	<b>4</b>	<b>56</b>	<b>4</b>	<b>2232</b>



**Figure 44. Number of Pedestrian Fatalities by TxDOT District and Road Class (2007–2011).**

The crashes that were recorded to be off the TxDOT system (720 or 32 percent) did not have most of their roadway characteristics recorded in the CRIS database. Additionally, 11 crashes that occurred on the system did not have most roadway characteristics recorded in the database. A total of 731 or 33 percent of the 2232 fatal pedestrian crashes did not have most roadway characteristics recorded in the database. As shown in Table 97, among those with number of lanes information, the most commonly occurring group of crashes were on roadways with four lanes. Similarly, among those with roadway information available, Table 98 shows that the most commonly occurring group of crashes (795/2232 or 36 percent) were on roadways with shoulder width between 10 and 12 ft. Table 99 shows the number of fatal pedestrian crashes by median type and median width; the most common (653/2232 or 29 percent) crashes occurred at locations with no median. These observations could be a reflection of the higher number of crashes occurring on Interstates and highways within an urban setting or just a reflection of more four-lane roadways with no median and shoulder width of 10–12 ft in Texas.

**Table 97. Fatal Pedestrian Crashes by Functional System and Number of Lanes.**

<b>Number of Lanes/ Functional System</b>	<b>Rural Interstate</b>	<b>Rural Principal Arterial</b>	<b>Rural Minor Arterial</b>	<b>Rural Major Collector</b>	<b>Rural Minor Collector</b>	<b>Rural Local</b>	<b>Urban Principal Arterial (IH)</b>	<b>Urban Principal Arterial (other freeway)</b>	<b>Urban Principal Arterial (other)</b>	<b>Urban Minor Arterial</b>	<b>Urban Collector</b>	<b>Blank</b>	<b>Total</b>
2		26	63	102	22	1		1	43	62	18		<b>338</b>
3			1										<b>1</b>
4	64	69	20	7			69	70	212	41	5		<b>557</b>
5	1						12	6	3	4			<b>26</b>
6	6	3					138	92	114	2			<b>355</b>
7							13	3					<b>16</b>
8							104	28	13				<b>145</b>
9							12	1	1				<b>14</b>
10							28	13					<b>41</b>
11								1					<b>1</b>
12								6	1				<b>7</b>
Blank												731	<b>731</b>
<b>Total</b>	<b>71</b>	<b>98</b>	<b>84</b>	<b>109</b>	<b>22</b>	<b>1</b>	<b>376</b>	<b>221</b>	<b>387</b>	<b>109</b>	<b>23</b>	<b>731</b>	<b>2232</b>

**Table 98. Fatal Pedestrian Crashes by Number of Lanes and Right Shoulder Width.**

<b>Number of Lanes/ Right Shoulder Width</b>	<b>0</b>	<b>1-3</b>	<b>4-6</b>	<b>7-9</b>	<b>10- 12</b>	<b>13- 18</b>	<b>19- 24</b>	<b>Blank</b>	<b>Total</b>
2	31	75	72	104	55	1	0	0	<b>338</b>
3	0	0	1	0	0	0	0	0	<b>1</b>
4	118	21	37	69	303	7	2	0	<b>557</b>
5	4	0	0	5	17	0	0	0	<b>26</b>
6	92	9	11	20	223	0	0	0	<b>355</b>
7	1	0	2	1	11	1	0	0	<b>16</b>
8	9	0	4	0	132	0	0	0	<b>145</b>
9	1	0	2	0	11	0	0	0	<b>14</b>
10	0	0	1	3	36	1	0	0	<b>41</b>
11	0	0	0	0	1	0	0	0	<b>1</b>
12	1	0	0	0	6	0	0	0	<b>7</b>
Blank	0	0	0	0	0	0	0	731	<b>731</b>
<b>Total</b>	<b>257</b>	<b>105</b>	<b>130</b>	<b>202</b>	<b>795</b>	<b>10</b>	<b>2</b>	<b>731</b>	<b>2232</b>

**Table 99. Fatal Pedestrian Crashes by Median Type and Median Width.**

<b>Median Type/ Median Width</b>	<b>0</b>	<b>1-6</b>	<b>7-12</b>	<b>13-18</b>	<b>19-24</b>	<b>25-50</b>	<b>51- 100</b>	<b>&gt;100</b>	<b>Blank</b>	<b>Total</b>
No Median	653	0	0	0	0	0	0	0	0	<b>653</b>
Curbed	0	4	16	26	21	22	2	4	0	<b>95</b>
Positive Barrier	0	4	8	42	84	239	89	2	0	<b>468</b>
Unprotected	0	0	2	1	4	100	155	16	0	<b>278</b>
One-Way Pair	6	0	0	1	0	0	0	0	0	<b>7</b>
Blank	0	0	0	0	0	0	0	0	731	<b>731</b>
<b>Total</b>	<b>659</b>	<b>8</b>	<b>26</b>	<b>70</b>	<b>109</b>	<b>361</b>	<b>246</b>	<b>22</b>	<b>731</b>	<b>2232</b>

**Geometric Characteristics (from Aerial Photographs)**

As shown in the previous section, 731 (33 percent) of the 2232 fatal pedestrian crashes did not have most roadway characteristics recorded in the TxDOT CRIS database. Researchers used aerial photographs to gather additional geometric information associated with the 2232 fatal pedestrian crashes. Table 76 lists the information gathered for this task. Geometric characteristics for 29 (i.e., 1 percent) of the TxDOT-reportable fatal pedestrian crashes between 2007 and 2011 could not be identified due to unavailable latitude-longitude information or crash location being off roadway. This section discusses characteristics of the remaining 2203 TxDOT-reportable fatal pedestrian crashes.

Ninety-three percent of the fatal pedestrian crashes were on roads without on-street parking. As shown in Table 100, most crashes (64 percent) occurred at midblock locations with no traffic



control. Among the 555 crashes that occurred at intersections, 38 percent occurred at locations with marked crosswalks. Three percent of the fatal crashes (66/2203) occurred in school zones and, as shown in Table 101, a quarter of the fatal crashes (557/2203) occurred at locations with sidewalks and roadway lighting.

As shown in Table 102, the most common (39 percent, 861/2203) category of crashes occurred at locations with no median, and the median width ranged from 0 to 462 feet. Figure 45 shows the distribution of median width by number of lanes.

As shown in Table 103, most fatal crashes occurred on roads with 4 and more lanes (68 percent, 1496/2203). Figure 46 shows that crossing width to refuge ranged from 10 to 285 feet, with crossing width increasing with number of lanes. Review of the crash locations showed that 59 percent of the crashes occurred on arterials, 11 percent occurred on residential streets, and the remaining 30 percent occurred on freeways. Chapter 11 discusses freeway pedestrian crashes in detail.

**Table 100. Distribution of Fatal Pedestrian Crashes by Crash Location and Traffic Control Type.**

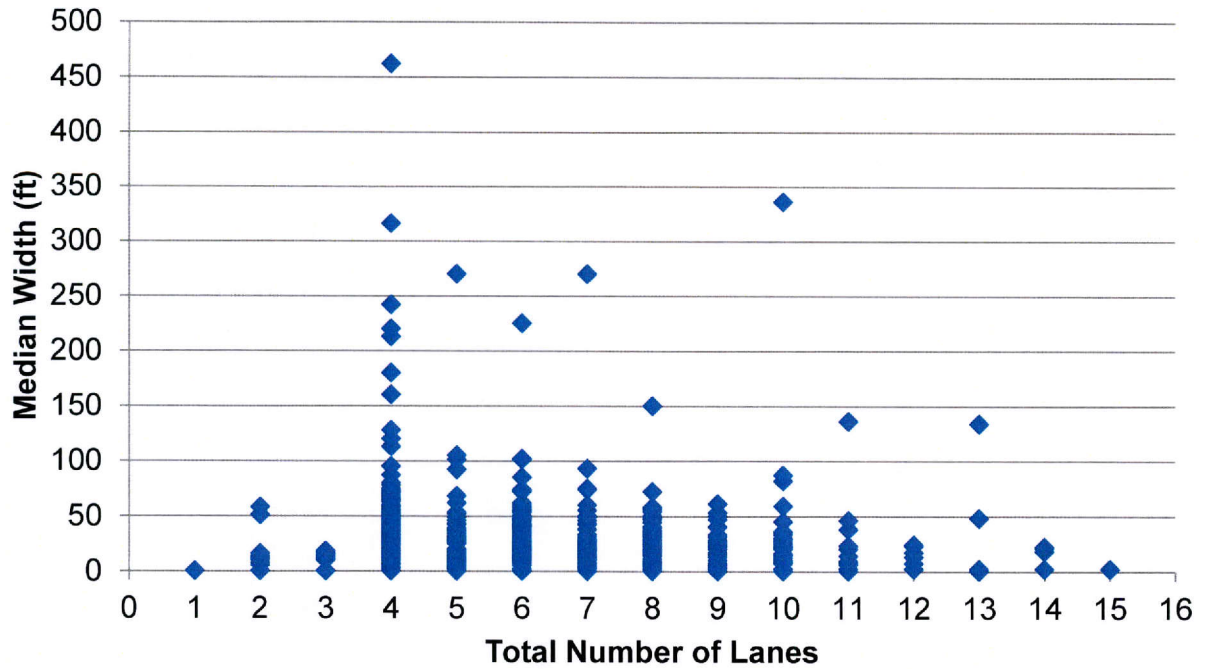
Traffic Control Type	Driveway	Intersection	Midblock	Total	Percentage
Beacon	0	7	0	7	0%
No Control	228	37	1414	1679	76%
Signal	2	216	0	218	10%
Stop Sign	4	295	0	299	14%
Total	234	555	1414	2203	100%
Percentage	11%	25%	64%	100%	

**Table 101. Distribution of Fatal Pedestrian Crashes by Presence of Sidewalk and Presence of Roadway Lighting.**

Main: Presence of Sidewalk	Main: Presence of Roadway Lighting		Total	Percentage
	No	Yes		
No	816	725	1541	70%
Yes	105	557	662	30%
Total	921	1282	2203	100%
Percentage	42%	58%	100%	0%

**Table 102. Distribution of Fatal Pedestrian Crashes by Median Type and Median Width.**

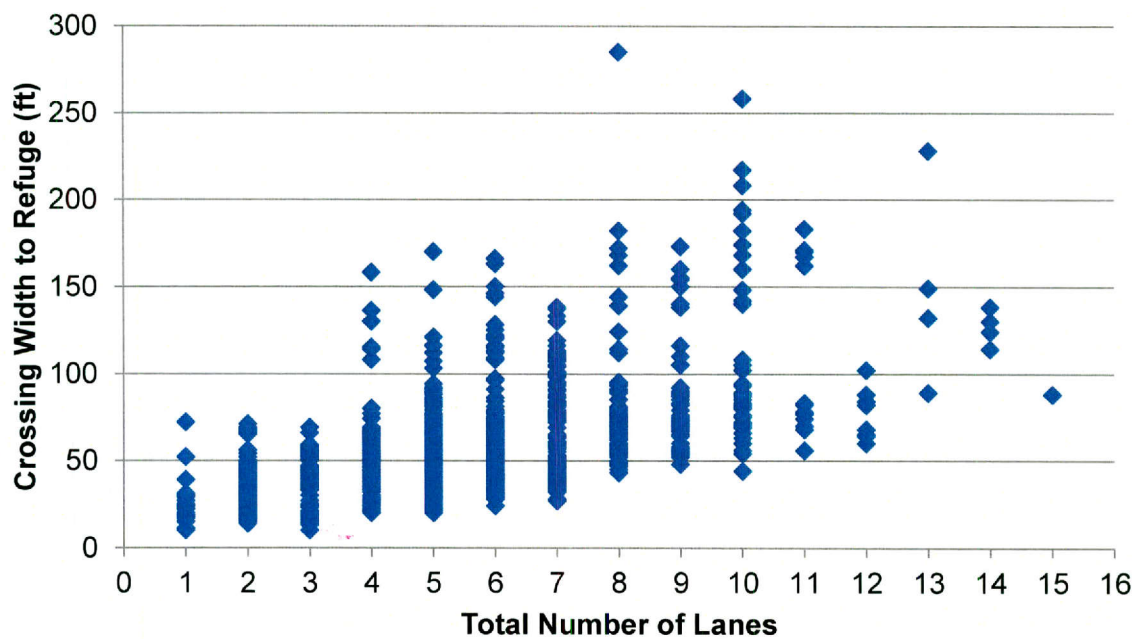
Main: Median Width (ft)	Barrier	Divided	Flush	None	Raised	TWLTL	Total	Percentage
0	0	0	0	861	0	0	861	39%
2-6	111	0	13	0	85	0	209	9%
7-12	22	2	26	0	66	75	191	9%
13-24	109	7	20	0	101	270	507	23%
25-36	121	26	0	0	39	3	189	9%
37+	102	121	1	0	22	0	246	11%
Total	465	156	60	861	313	348	2203	100%
Percentage	21%	7%	3%	39%	14%	16%	100%	0%



**Figure 45. Distribution of Fatal Pedestrian Crashes by Median Width and Total Number of Lanes.**

**Table 103. Distribution of Fatal Pedestrian Crashes by Total Number of Lanes and Number of Left-Turn Lanes.**

Main: Total Number of Lanes	Main: Number of Left-Turn Lanes			Total	Percentage
	0	1	2		
1	44	0	0	44	2%
2	585	0	0	585	27%
3	23	55	0	78	4%
4	378	7	0	385	17%
5	30	349	2	381	17%
6	194	24	21	239	11%
7	32	187	8	227	10%
8	110	9	4	123	6%
9	43	12	2	57	3%
10	48	0	2	50	2%
11	15	0	0	15	1%
12	9	0	0	9	0%
13	4	0	0	4	0%
14	5	0	0	5	0%
15	1	0	0	1	0%
Total	1521	643	39	2203	100%
Percentage	69%	29%	2%	100%	0%



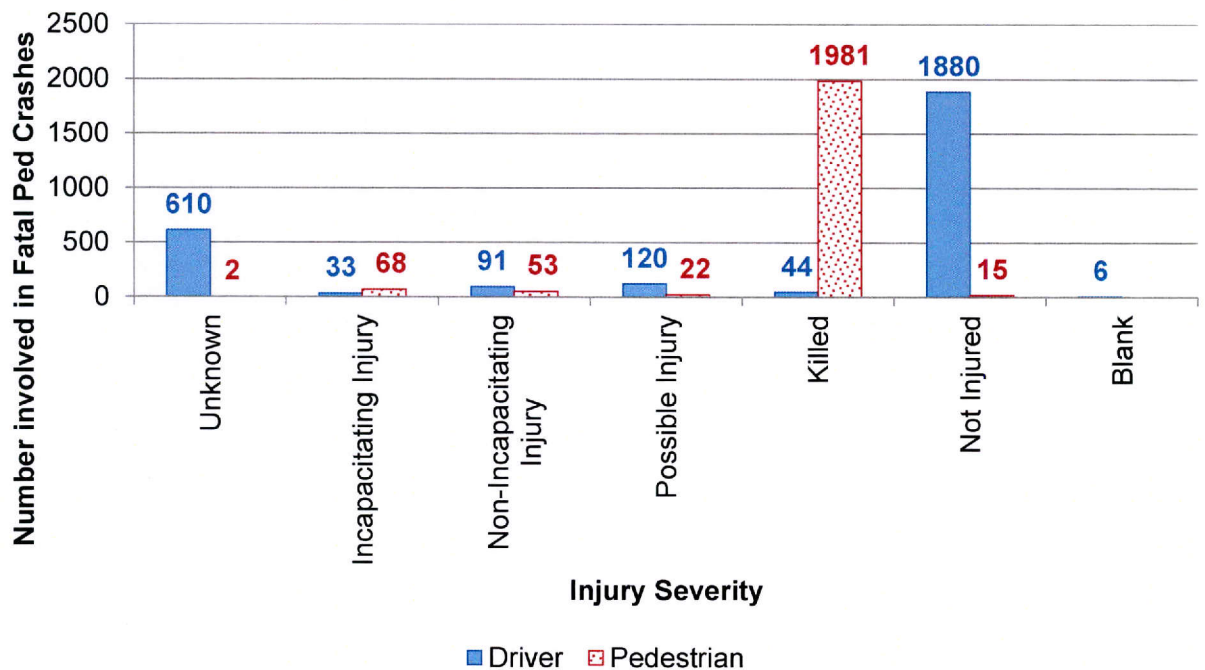
**Figure 46. Distribution of Fatal Pedestrian Crashes by Crossing Width to Refuge and Total Number of Lanes.**

## Person Characteristics

A total of 6373 persons were involved in the 2232 fatal crashes identified for this analysis (each crash could have more than one person involved). Pedestrians and drivers were identified in this database using the person occupant position and person type variables. POP of 1 or PT of 1 or 5 represent drivers (2784 records) and POP of 16 and PT of 4 represent a pedestrian (2141 records). Of the 6373 records, 44 percent (2784 records) indicated a driver and 34 percent (2141 records) indicated a pedestrian. Table 104 shows the distribution of crash records (by injury severity) for pedestrians and drivers. As shown in Figure 47, in fatal pedestrian crashes a very high proportion of pedestrians are killed, whereas most drivers or passengers at the most sustain injuries.

**Table 104. Number of Fatal Crash Records by Person Occupant Position.**

Injury Severity	Pedestrian		Driver	
	Number	Percent	Number	Percent
Unknown	2	0%	610	22%
Incapacitating Injury	68	3%	33	1%
Non-Incapacitating Injury	53	2%	91	3%
Possible Injury	22	1%	120	4%
Killed	1981	93%	44	2%
Not Injured	15	1%	1880	68%
Blank		0%	6	0%
<b>Total</b>	<b>2141</b>	<b>100%</b>	<b>2784</b>	<b>100%</b>



**Figure 47. Number of Fatal Crash Records by Injury Severity of Those Involved (2007–2011).**

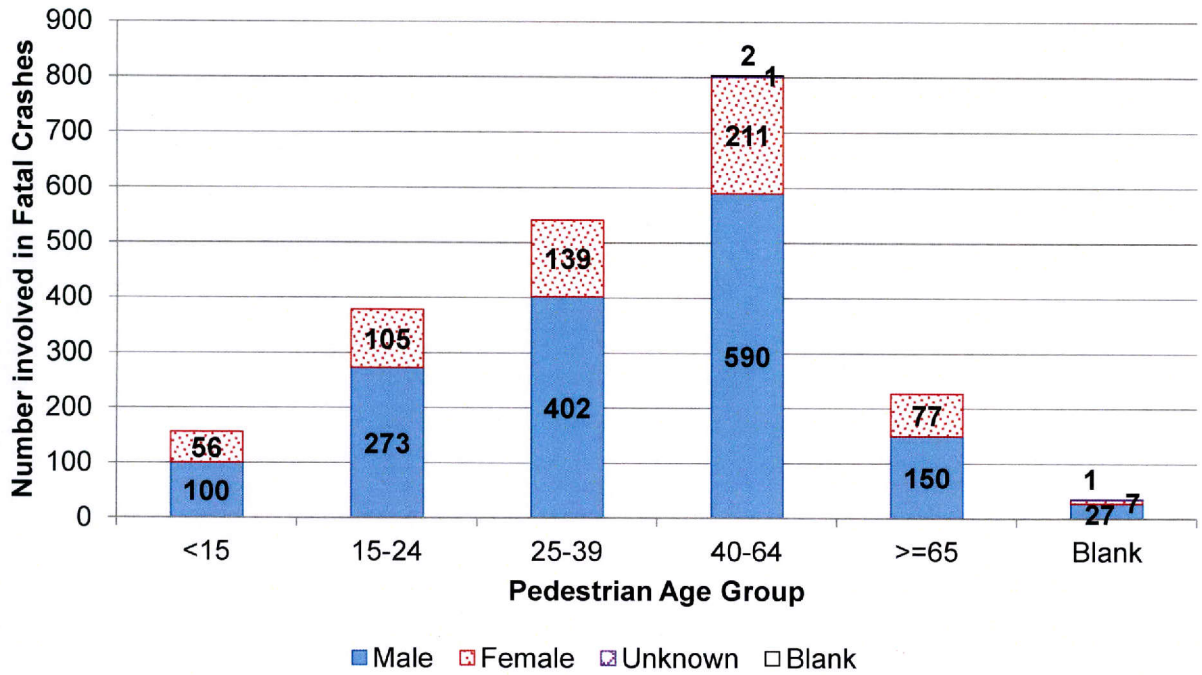
As shown in Figure 47, of the 2141 pedestrians involved in fatal pedestrian crashes, 1981 pedestrians were killed, 143 were injured, 15 were not injured, and the final 2 pedestrians' injury severity is not known. Table 105 shows a distribution of age of the 1981 pedestrians killed in pedestrian-related crashes. Overall, from 2007–2011 in Texas, 8 percent and 11 percent of pedestrians killed in pedestrian-related crashes were of age 15 or less and age 65 or above, respectively. Nationally in 2010, 7 percent and 19 percent of pedestrian fatalities involve pedestrians of age 15 or less and age 65 or above, respectively (175).

**Table 105. Age Distribution of Pedestrians Killed in Fatal Pedestrian-Related Crashes.**

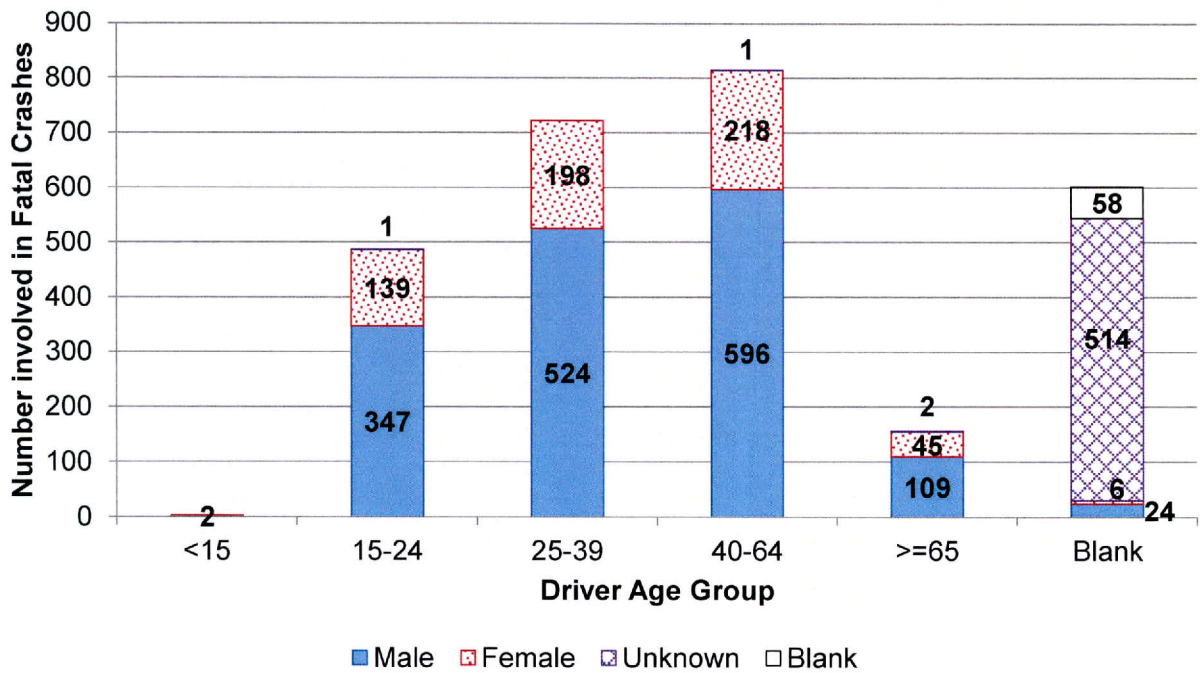
Age Group	2007–2011 Peds Killed, CRIS		2010 Peds Killed, NHTSA (175)	
	Number	Percentage	Number	Percentage
≤15	155	8%	293	7%
16–24	310	16%	559	13%
25–39	492	25%	880	21%
40–64	770	39%	1705	40%
≥65	223	11%	826	19%
Blank	31	2%	17	0.4%
<b>Total</b>	<b>1981</b>	<b>100%</b>	<b>4280</b>	<b>100%</b>

Figure 48 shows a distribution of age group and gender among pedestrians (2141) and drivers (2784) involved in fatal pedestrian-related crashes. As shown in the figure, more male pedestrians are killed in traffic crashes than females. Overall, 72 percent of pedestrians involved in fatal crashes were males. Nationally, this statistic is 69 percent (175). Similarly, more male drivers are involved in pedestrian-related fatal crashes. This could also be a reflection of a higher proportion of men in Texas' population or the general belief that men have a more risk-taking tendency than women.

The pedestrian age group involved in the largest number of fatal pedestrian crashes is 40–64 years old (see Figure 48a). A similar number of drivers in the age groups 25–39 and 40–64 (see Figure 48b) were involved in fatal pedestrian-related crashes. Again, this could also be a reflection of a higher proportion of people in these age groups in Texas; however, as shown in Figure 49, overall, more Texans are in the age group of 40–64, with the proportion of male and female being similar.

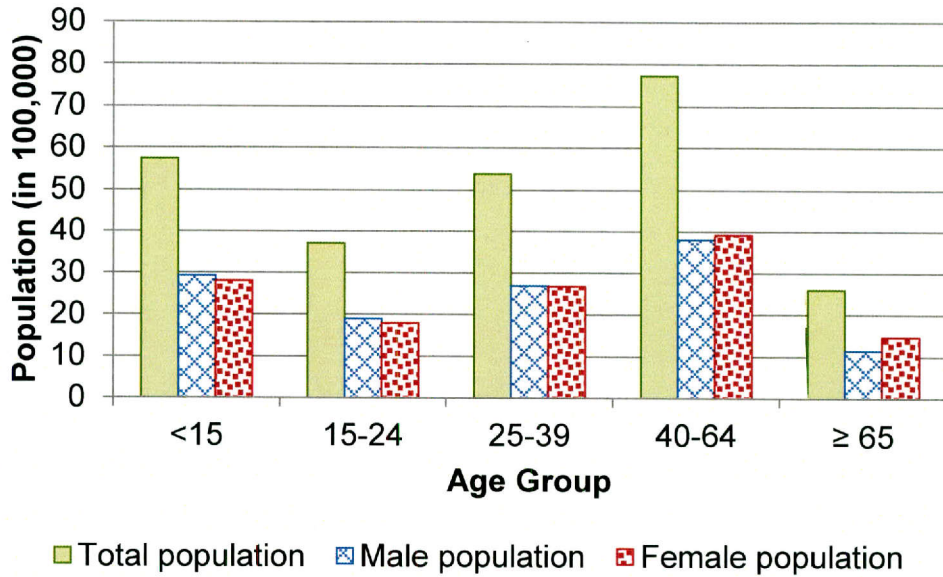


a) Pedestrian Age Group Distribution



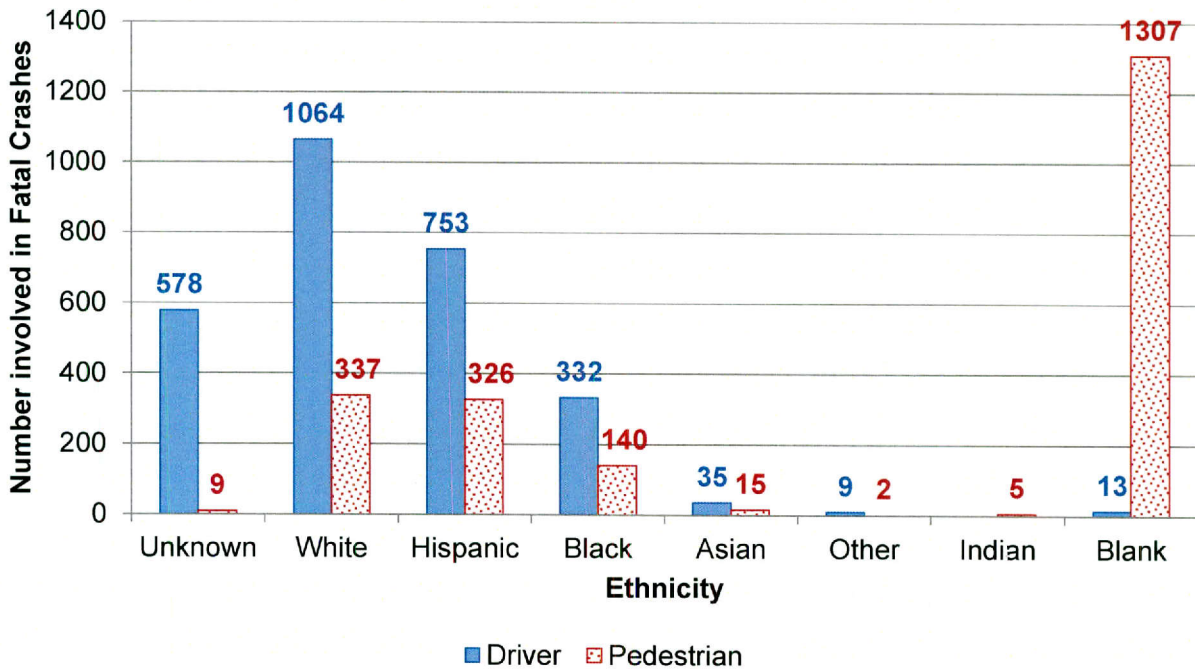
b) Driver Age Group Distribution

Figure 48. Age Group Distribution by Gender of Pedestrian Involved in Fatal Crashes (2007–2011).



**Figure 49. Age Group Distribution by Gender – U.S. Census Data for 2010 (176).**

Figure 50 shows ethnicity of drivers and pedestrians involved in fatal crashes. The database does not have ethnicity information for 61 percent (1307/2141) of the pedestrians. Among the data with ethnicity record, pedestrians of white or Hispanic ethnicity have the highest number of crashes. Again, this could also be a reflection of over- or underrepresentation of the ethnicity in the database.



**Figure 50. Ethnicity Distribution of Drivers and Pedestrians Involved in Fatal Pedestrian-Related Crashes (2007–2011).**

Alcohol test results for only 14 percent (908/6373) of the persons involved in fatal pedestrian crashes were reported, which is much less than the 47 percent reported nationally (175). Table 106 shows a distribution of alcohol test results for drivers and pedestrians involved in fatal pedestrian crashes. No alcohol test result information was available for most drivers (87 percent) and pedestrians (76 percent). Of the available results, more pedestrians (63 percent) tested positive than drivers (35 percent). Based on the blood alcohol content (BAC) test results shown in Table 107, a higher proportion of pedestrians (19 percent) were tested to be over the legal limit (0.08 BAC) than drivers (13 percent). The percent of pedestrians with more than 0.08 BAC is much less compared to the national observation of 33 percent, whereas the driver observation is similar at 14 percent (175). Another variable indicating impaired walking or driving is the drug specimen result. The distribution of drug specimen result is shown in Table 108. Drug specimen results were either unavailable or unknown for some drivers (24 percent) and pedestrians (38 percent). Of those available, a much higher proportion of pedestrians (10 percent) tested positive when compared to drivers (2 percent).

**Table 106. Alcohol Test Result of Drivers and Pedestrians Involved in Fatal Pedestrian Crashes (2007–2011).**

Alcohol Result	Driver		Pedestrian	
	Number	Percent	Number	Percent
Positive	122	4	325	15
Negative	225	8	194	9
Blank	2422	87	1622	76
<b>Total</b>	<b>2769</b>	<b>100</b>	<b>2141</b>	<b>100</b>

**Table 107. BAC Test Result of Drivers and Pedestrians Involved in Fatal Pedestrian Crashes (2007–2011).**

BAC Results	Driver		Pedestrian	
	Number	Percent	Number	Percent
0	288	10	408	19
0.01–0.07	13	0	11	1
0.08+	46	2	100	5
Blank	2422	87	1622	76
<b>Total</b>	<b>2769</b>	<b>100</b>	<b>2141</b>	<b>100</b>

**Table 108. Drug Test Result of Drivers and Pedestrians Involved in Fatal Pedestrian Crashes (2007–2011).**

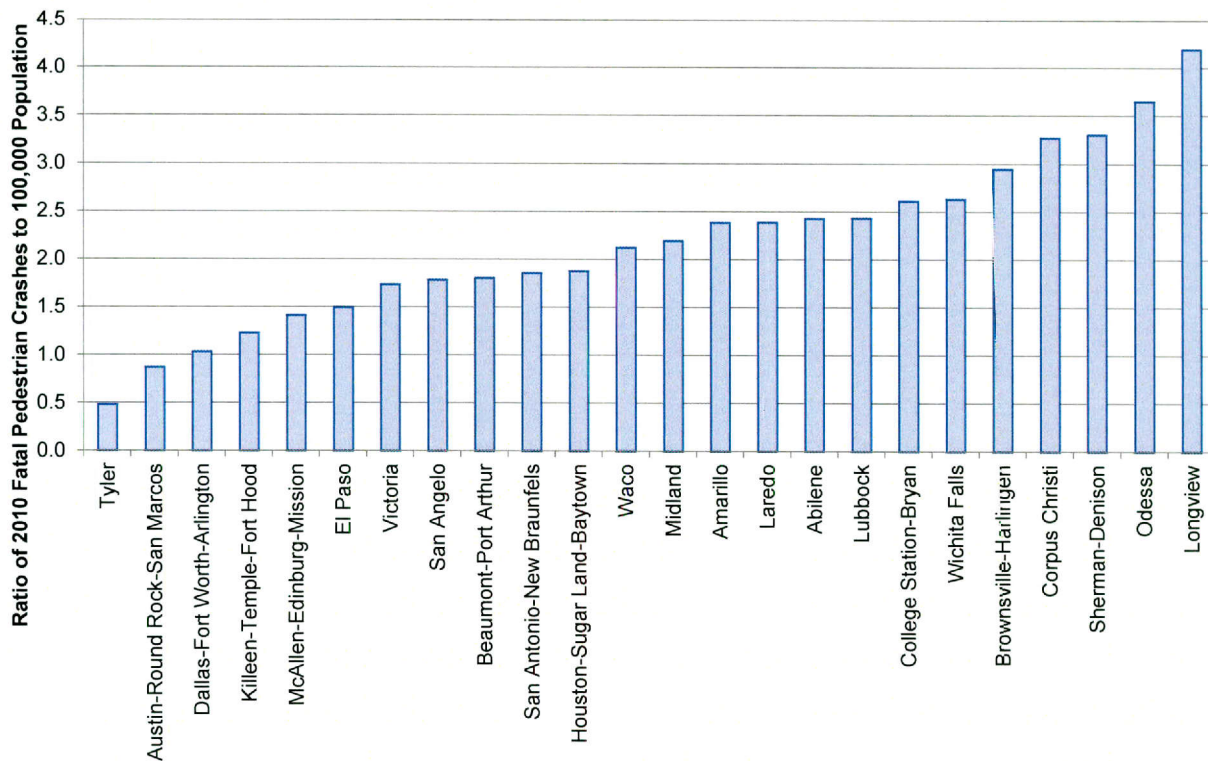
Drug Result	Driver		Pedestrian	
	Number	Percent	Number	Percent
Unknown	53	2	48	2
Positive	38	1	129	6
Negative	153	6	213	10
Not Applicable	1921	69	976	46
Blank	604	22	775	36
<b>Total</b>	<b>2769</b>	<b>100</b>	<b>2141</b>	<b>100</b>



## Socioeconomic Characteristics

Numerous studies in literature have discussed the impact of different socioeconomic factors on crashes, especially pedestrian crashes (e.g., 177). Socioeconomic data for each of the 24 metropolitan statistical areas (MSAs) were obtained from the 2010 U.S. Census data and the accompanying American Community Survey (ACS) to obtain an appreciation of the socioeconomic characteristics of Texas fatal pedestrian crashes (176). In this section, the 2010 crash data are compared to the 2010 estimate of various socioeconomic indicators for the 24 MSAs.

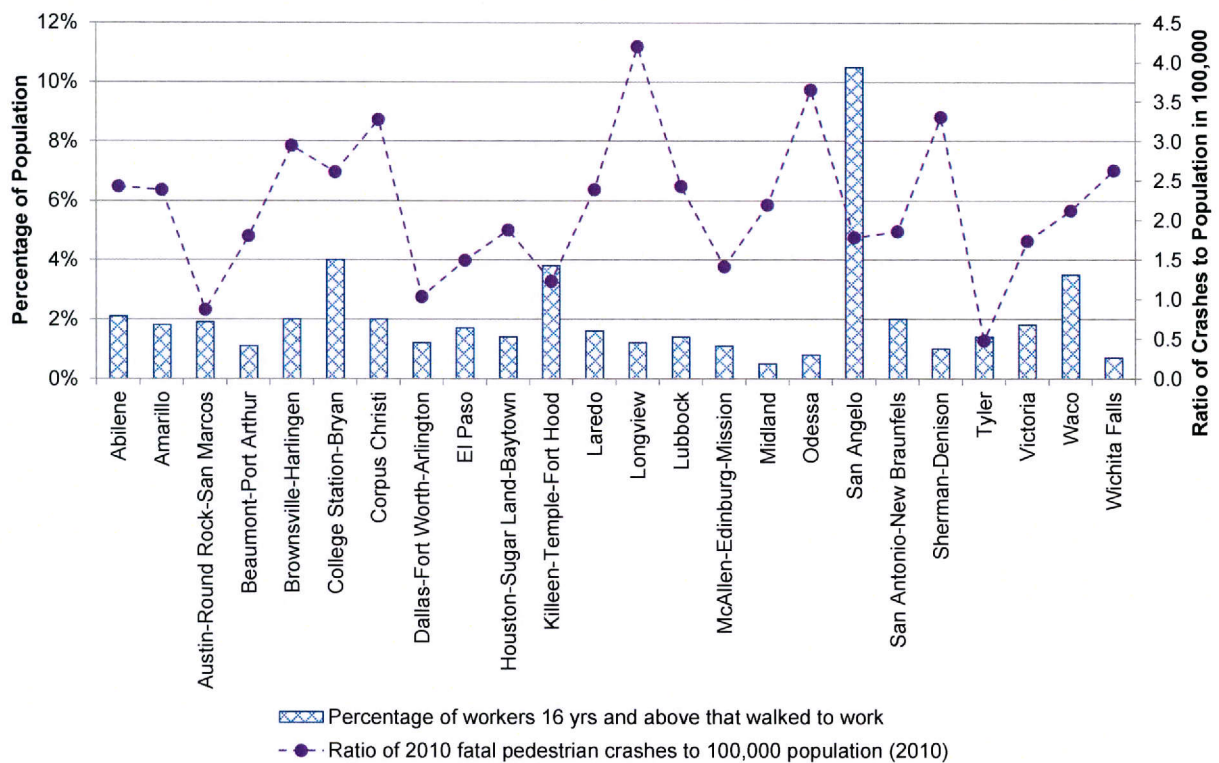
Figure 51 shows the ratio of fatal pedestrian crashes to the population (in 100,000) for 2010 in ascending order. As shown in the figure, Tyler had the lowest ratio and Longview had the highest followed by Odessa, Sherman-Denison, Corpus Christi, and Brownsville-Harlingen.



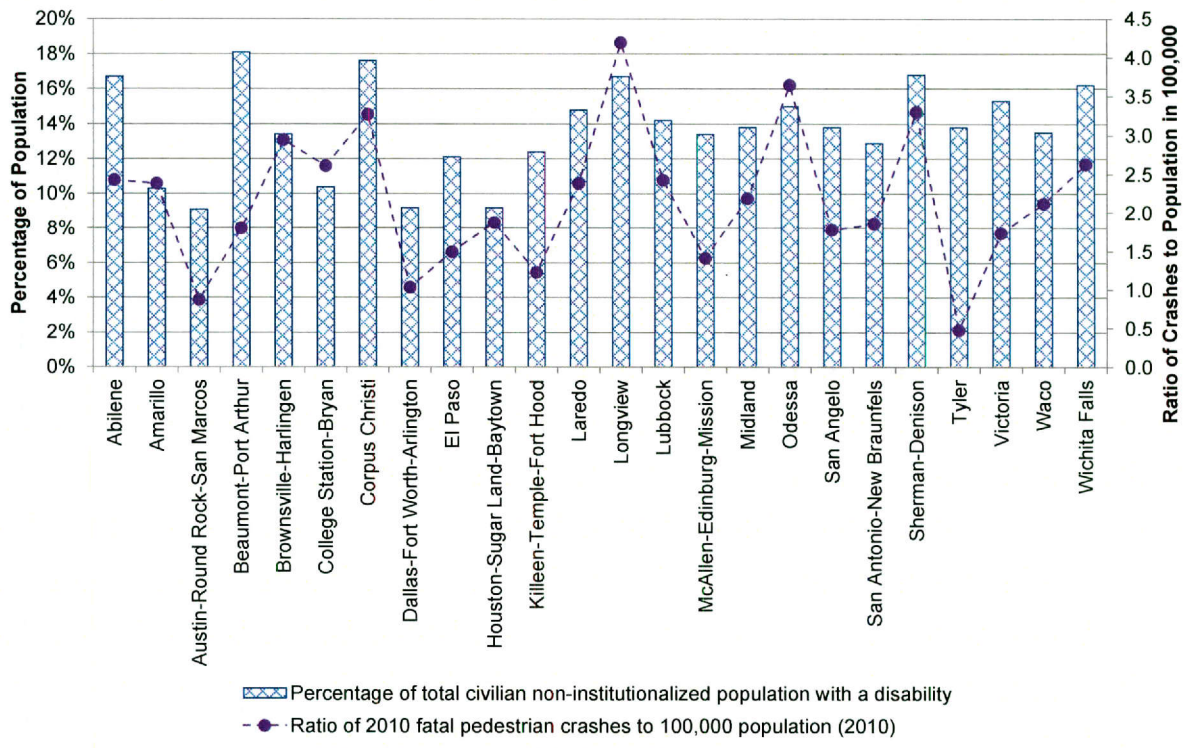
**Figure 51. Ratio of 2010 Fatal Pedestrian-Related Crashes to 2010 Population.**

Figure 52 shows the comparison of the 2010 ACS estimated percentage of population (16 years and above) that walks to work with the ratio of crashes to population in 2010. San Angelo is estimated to have the highest percentage of population walking, but has a comparatively lower ratio of crashes to population in 2010. However, this pattern is not consistent among all the 24 MSAs. Figure 53 shows the comparison of the 2010 ACS estimated percentage of population (civilian and non-institutionalized) that has a disability with the ratio of crashes to population in 2010. Beaumont-Port Arthur and Corpus Christi are estimated to have the highest proportion of non-institutionalized civilians with a disability, but Corpus Christi has a comparatively higher ratio of crashes to population than Beaumont-Port Arthur. Figure 54 shows the comparison of the

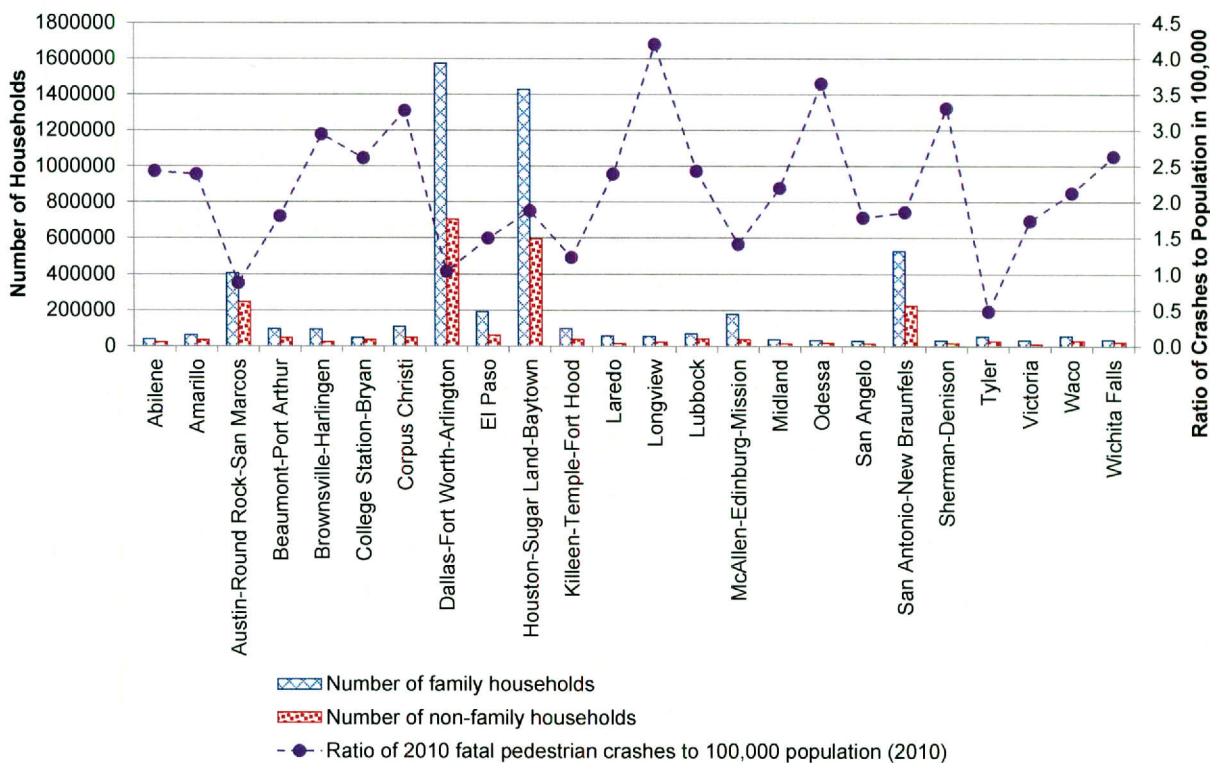
2010 ACS estimated number of households (both family and non-family) with the ratio of crashes to population in 2010. As expected, Dallas-Fort Worth-Arlington and Houston-Sugar Land-Baytown have the highest number of households, but a comparatively lower ratio of crashes to population. This trend is seen across all the 24 MSAs. Figure 55 shows the comparison of the 2010 ACS estimated percentage of population (25 years and above) that is high school and above graduates and the estimated percentage of population (5 years and above) that speaks English less than “very well” with the ratio of crashes to population in 2010. El Paso, Brownsville-Harlingen, and McAllen-Edinburg-Mission have the highest proportion of population that speaks English less than very well. El Paso and Brownsville-Harlingen have a comparatively higher ratio of crash to population than McAllen-Edinburg-Mission. This mixed trend is seen across the 24 MSAs. Figure 56 shows the comparison of the 2010 ACS estimated per capita income with the ratio of crashes to population in 2010. Midland and Austin-Round Rock-San Marcos have a comparatively higher per capita income than Longview and also a comparatively lower ratio of crash to population. This trend is observed across the 24 MSAs. In summary, the variables explored in this section do provide some insights into the relation between fatal pedestrian crashes and socioeconomic measures, but a clearer understanding can only be obtained with further detailed analysis.



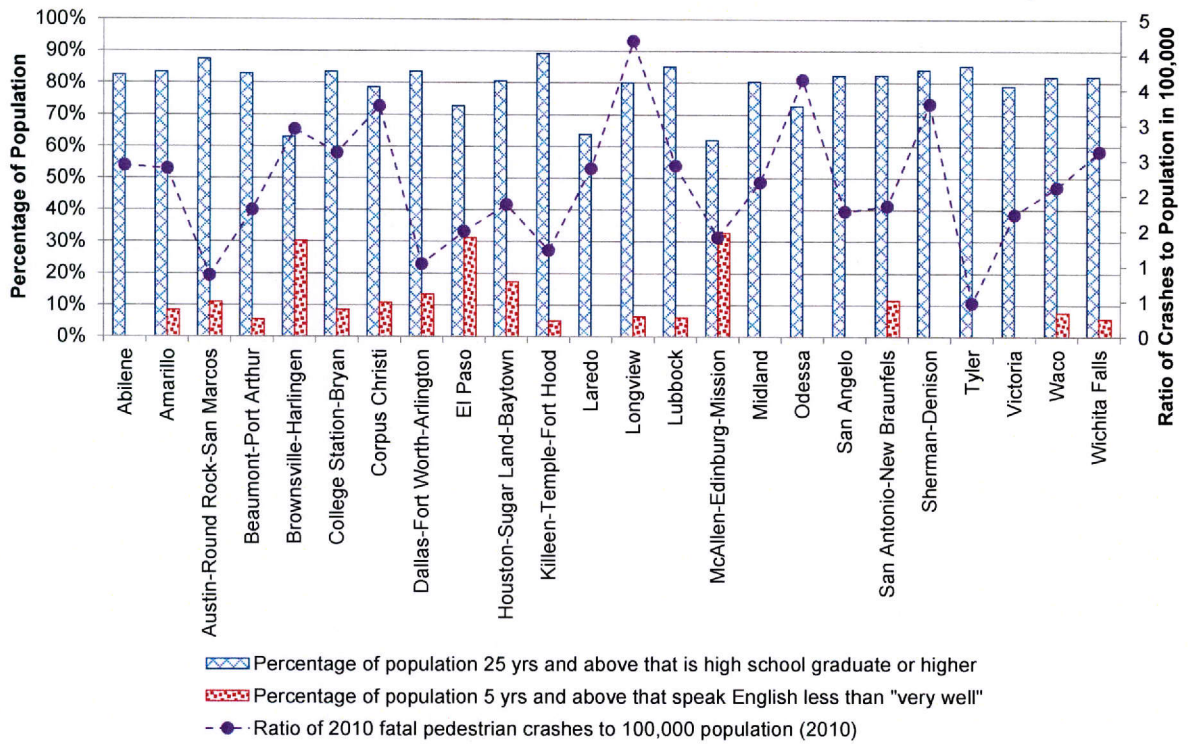
**Figure 52. Proportion of 2010 Population 16 Years and above That Walked to Work (176).**



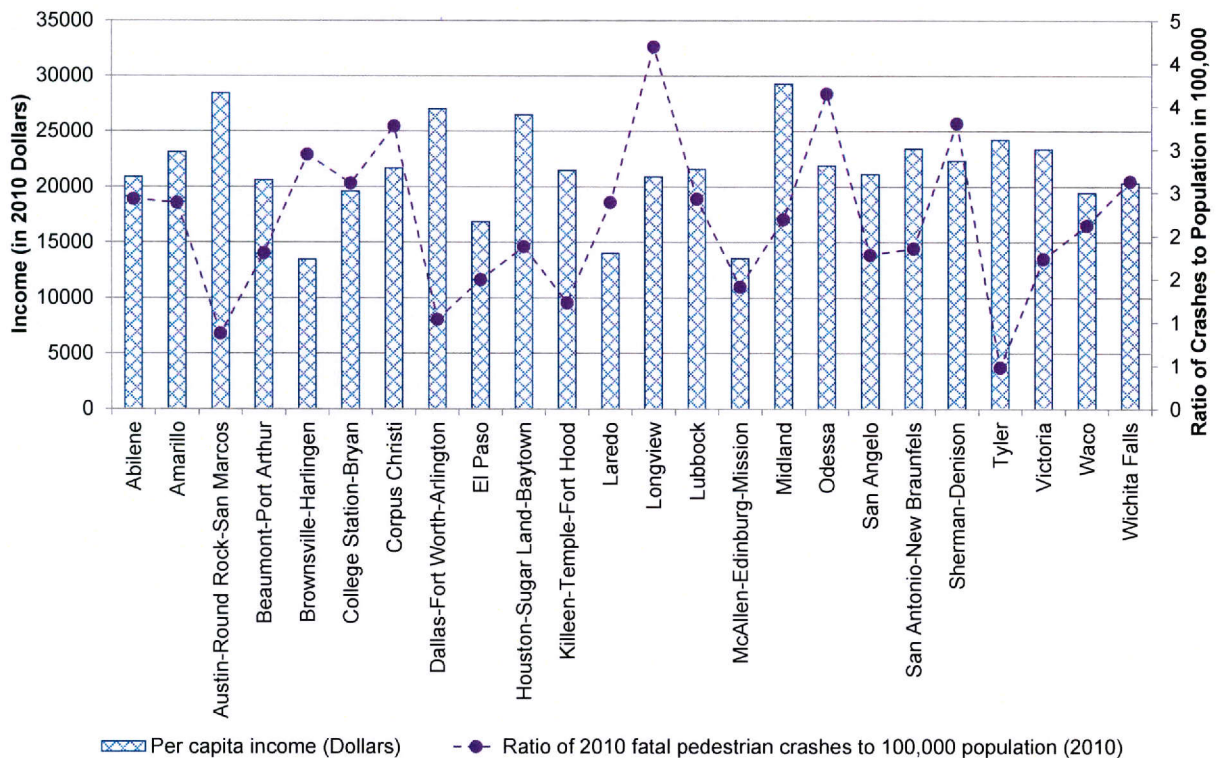
**Figure 53. Proportion of 2010 Civilian Non-Institutionalized Population with Disability (176).**



**Figure 54. Number of Households in the 2010 Census Data (176).**



**Figure 55. Proportion of 2010 Population with High School Education and English Speaking Ability (176).**



**Figure 56. Per Capita Income in 2010 Census Data (176).**

## DISCUSSION

A total of 2232 TxDOT-reportable fatal pedestrian crashes were identified between 2007 and 2011, which is 15 percent of all TxDOT-reportable fatal crashes. The percent of TxDOT-reportable fatal crashes involving a pedestrian increased in 2011 when compared to 2010 and 2009 (17 percent compared to 14 percent). Table 109 summarizes the findings from this review, along with comparable data from FARS.

**Table 109. Summary of Fatal Pedestrian Crashes in Texas in Comparison with National Data (175).**

Fatal Pedestrian Crash Characteristic	2010 FARS Data	2007–2011 TxDOT-Reportable CRIS Data
Urban	73%	76%
Non-Intersection	79%	87%
In Clear/Cloudy Weather Condition	88%	93%
Nighttime	68%	73%
Pedestrians age 65+	19%	11%
Pedestrians age ≤15	7%	7%
Male Pedestrian	69%	72%
Between 8 p.m.–11:59 p.m.	30%	32%
Weekend (Fri–Sun)	48%	50%
Alcohol Reported	47%	18%
Pedestrian with BAC ≥ 0.08	33%	19%*
Driver with BAC ≥ 0.08	14%	13%*
*Percentage of those with alcohol results		

In 2010, the Tyler metropolitan area had the least ratio of fatal pedestrian crashes to population (per 100,000), whereas Longview had the highest followed by Odessa, Sherman-Denison, Corpus Christi, and Brownsville-Harlingen. Overall (i.e., 2007–2011), TxDOT districts with bigger cities had more fatal pedestrian crashes.

Eighty-nine percent of crashes happened when the vehicle involved was going straight, and most often on a level and straight roadway. Most crashes occurred in clear or cloudy conditions (93 percent) with more crashes in dark conditions (73 percent) than in daylight (23 percent). The numbers peaked at dawn and dusk for crashes at intersections (6 a.m. and 6 p.m.), whereas for crashes at non-intersection locations, the peaks were at late night and early morning hours (2 a.m. and 9 p.m.).

Fifty-two percent of all fatal pedestrian crashes were identified to have occurred on Interstate, U.S., or State Highways in the TxDOT CRIS database. Review of geometric characteristics (from aerial photographs) for 2203 of the TxDOT-reportable fatal pedestrian crashes showed that 59 percent of the crashes occurred on arterials, 11 percent occurred on residential streets, and the remaining 30 percent occurred on freeways. Ninety-three percent of the fatal pedestrian crashes

were on roads without on-street parking. Most crashes (64 percent) occurred at midblock locations with no traffic control. Among the 555 crashes that occurred at intersections, 38 percent occurred at locations with marked crosswalks. Three percent of the fatal crashes (66/2203) occurred in school zones, and a quarter of the fatal crashes (557/2203) occurred at locations with sidewalks and roadway lighting. Most commonly (39 percent, 861/2203), crashes occurred at locations with no median and the median width ranged from 0 to 462 feet. Most fatal crashes occurred on roads with 4 and more lanes (68 percent, 1496/2203) and the crossing width to refuge ranged from 10 to 285 feet, with crossing width increasing with number of lanes.

## **SUMMARY**

This research effort provided an understanding of Texas fatal pedestrian crashes from an exploratory analysis of 2232 TxDOT-reportable fatal pedestrian crashes (identified from the TxDOT CRIS data set for 2007–2011). Various crash, person, and socioeconomic characteristics associated with these crashes are discussed, such as 76 percent of crashes occurred at urban locations, 73 percent of crashes occurred in darkness, and 38 percent of the pedestrians were in the age group 41–64 years.

## CHAPTER 11

# REVIEW OF FATAL PEDESTRIAN CRASHES ON HIGH-SPEED ROADS IN TEXAS

### BACKGROUND

Over the most recent 5-year period available (2007–2011), 2232 fatal TxDOT-reportable pedestrian crashes were identified in the TxDOT Crash Record Information System database, of which 52 percent occurred on the highest speed roadways, i.e., Interstates or U.S. and State highways. This is a concern and the main impetus for this sub-study.

In a 1997 study using 1992–1994 national data, Johnson found that Texas had the most Interstate pedestrian fatalities per 100 million Interstate vehicle-kilometers traveled, and also the most Interstate vehicle kilometers traveled (178). Based on more recent data (2007–2011) from FARS and FHWA Office of Highway Policy Information, Texas has the fourth most Interstate highway pedestrian fatalities per 100 million Interstate vehicle-miles traveled (shown in Table 110) (179, 180).

To understand the characteristics and contributing factors of fatal TxDOT-reportable pedestrian crashes on high-speed controlled-access roadways, a detailed review of crash narrative/reports of TxDOT-reportable fatal pedestrian crashes on Interstates or U.S. and State highways was conducted.

### DATA ASSEMBLY

#### Crash Data

Crash data used in this analysis were derived from the data set described in Chapter 9 (in-depth review of Texas pedestrian crashes). Fatal crashes in the database were identified using the “crash severity” variable. All crash IDs with crash severity of 4 (i.e., fatal) were identified and the crash, person, and unit properties associated with these crash IDs extracted. Further, fatal TxDOT-reportable pedestrian crashes on high-speed roads were identified using the road class variable in the crash file with codes 1 (Interstate) or 2 (U.S. and State highway). A total of 1163 crashes were identified as fatal TxDOT-reportable pedestrian crashes on Interstates or U.S. and State highways.

**Table 110. State Ranking of Interstate Highway Pedestrian Fatalities per 100 Million Interstate Vehicle-Miles Traveled, 2007–2011.**

State	Rank	Interstate Pedestrian Fatalities (2007–2011) (179)	Interstate Vehicle-Miles of Travel (miles per 100 million) (180)	Ratio	State	Rank	Interstate Pedestrian Fatalities (2007–2011) (179)	Interstate Vehicle-Miles of Travel (miles per 100 million) (180)	Ratio
AL	1	124	818	0.1516	MI	27	71	1,520	0.0467
DC	2	6	40	0.1499	NY	28	106	2,271	0.0467
AK	3	11	82	0.1339	WA	29	53	1,148	0.0462
TX	4	599	4,706	0.1273	PA	30	74	1,749	0.0423
LA	5	81	718	0.1129	CT	31	30	733	0.0409
AR	6	58	575	0.1008	ID	32	9	220	0.0409
MO	7	129	1,393	0.0926	KY	33	32	869	0.0368
MA	8	102	1,123	0.0909	TN	34	45	1,227	0.0367
OK	9	62	724	0.0857	VA	35	54	1,519	0.0355
NC	10	120	1,473	0.0815	OH	36	68	1,987	0.0342
FL	11	208	2,613	0.0796	WY	37	6	180	0.0334
CA	12	577	7,376	0.0782	MT	38	6	185	0.0324
NM	13	32	421	0.0760	WV	39	11	345	0.0318
HI	14	10	133	0.0751	KS	40	16	520	0.0308
MD	15	89	1,201	0.0741	VT	41	3	99	0.0304
GA	16	124	1,720	0.0721	IL	42	52	1,710	0.0304
NJ	17	95	1,383	0.0687	IN	43	27	1,012	0.0267
MS	18	33	508	0.0650	ND	44	3	127	0.0236
AZ	19	66	1,080	0.0611	WI	45	22	951	0.0231
SC	20	48	794	0.0605	MN	46	21	956	0.0220
NV	21	23	391	0.0588	NE	47	6	310	0.0193
RI	22	9	173	0.0520	SD	48	3	166	0.0181
IA	23	24	477	0.0503	DE	49	1	111	0.0090
OR	24	29	593	0.0489	ME	50	1	199	0.0050
CO	25	43	894	0.0481	NH	51	1	229	0.0044
UT	26	24	508	0.0473					

**Crash Narrative**

The crash variables explored in this study are not available in the CRIS database in detail. This study looks at aspects of pedestrian crashes such as road type (based on access control), exact crash location (i.e., with respect to the roadway), what the pedestrian was doing at the time of collision, and why the pedestrian was at the crash location. This information was extracted by reviewing the narrative text and sketch, along with other coded information in the CR-3 crash reports.



Of the 1163 fatal TxDOT-reportable pedestrian crashes on Interstates or U.S. and State highways identified, 1023 crashes were included in this analysis after exclusions due to the reasons shown in Table 111.

**Table 111. Reason for Exclusion from Analysis.**

<b>Reason for Exclusion</b>	<b>Number of Crashes</b>
Crash report not available	15
Crash involved pedalcyclist or motorized conveyance	110
Crash did not involve pedestrian	9
Crash occurred in a parking lot	5
Crash occurred on a city street	1
<b>Total</b>	<b>140</b>

The crash narrative review was focused on the key questions described in Table 112. Information from the narrative text and other parts of the report was coded in a spreadsheet form for this analysis. Each row in the spreadsheet represented a fatal pedestrian crash, and the columns contained coded answers to the questions shown in Table 112. Officers' comments were not included in the analysis because in 87 percent (4141/474) of the fatal crashes on freeways there were no additional officer comments that were not captured in other fields collected for this study. The officer noted dark clothing of pedestrians in only 4 percent (17/474) of the fatal crashes on freeways.

## **ANALYSIS**

### **Roadway Type and Posted Speed Limit**

Type of roadway where the crash occurred was determined by using the latitude and longitude variables in the CRIS database, aerial photographs, and the crash narrative sketch. A "Freeway" was defined as an access-controlled facility, a "Frontage" was defined as a service road accompanying a freeway, and an "Arterial" was defined as any other non-access-controlled facilities.

As shown in Table 113, 21 percent (474/2232) of all fatal TxDOT-reportable pedestrian crashes occurred on access roadways. This is a very high proportion of pedestrian crashes at locations where pedestrians are least expected. In comparison, 5 percent of the fatal crashes (109/2232) occurred on frontage roads.

**Table 112. Information Extracted from Crash Narratives.**

Question of Interest	Code Used by Researchers to Document the Information
What type of roadway facility did the crash occur on?	<ul style="list-style-type: none"> <li>• Freeway (Access-controlled facility)</li> <li>• Frontage (Service road accompanying a freeway)</li> <li>• Arterial (All other non-access-controlled facilities)</li> </ul>
What part of the road did the crash occur on?	<ul style="list-style-type: none"> <li>• Main lanes</li> <li>• Right Shoulder</li> <li>• Left Shoulder</li> <li>• Entrance Ramp</li> <li>• Exit Ramp</li> <li>• Median</li> <li>• High-Occupancy-Vehicle (HOV) Lane</li> <li>• Crosswalk on Main lanes</li> <li>• Two-Way Left-Turn Lane</li> <li>• Off the Roadway</li> <li>• Unknown</li> </ul>
What was the pedestrian doing at the time of collision?	<ul style="list-style-type: none"> <li>• Standing</li> <li>• Crossing the roadway</li> <li>• Walking along the roadway</li> <li>• Lying down</li> <li>• Unknown</li> </ul>
Why was the pedestrian at the crash location?	<ul style="list-style-type: none"> <li>• Associated with a vehicle               <ul style="list-style-type: none"> <li>• Stalled vehicle</li> <li>• Previous crash</li> <li>• Changing seat positions</li> <li>• Jumping from car</li> <li>• Taking pictures</li> <li>• Retrieving items from road</li> </ul> </li> <li>• Not associated with a vehicle               <ul style="list-style-type: none"> <li>• Commuting</li> <li>• Working</li> <li>• Fleeing police</li> <li>• Suicide</li> <li>• Unconscious</li> <li>• Jumping from bridge</li> </ul> </li> <li>• Not stated in crash narrative               <ul style="list-style-type: none"> <li>• Crossing roadway</li> <li>• Standing in traffic</li> <li>• Standing on median, shoulder, or off the road</li> <li>• Walking or lying down in traffic</li> <li>• Walking or lying down on median, shoulder, or off the road</li> </ul> </li> <li>• Unknown</li> </ul>
Was the pedestrian under the influence of alcohol or drugs?	<ul style="list-style-type: none"> <li>• Alcohol and/or Drugs               <ul style="list-style-type: none"> <li>• Alcohol or “Had been drinking”</li> <li>• Drugs</li> <li>• Alcohol and Drugs</li> </ul> </li> <li>• Alcohol within limits</li> <li>• Not under influence</li> <li>• Unknown</li> </ul>
Was the driver under the influence of alcohol or drugs?	<ul style="list-style-type: none"> <li>• Alcohol and/or Drugs               <ul style="list-style-type: none"> <li>• Alcohol or “Had been drinking”</li> <li>• Drugs</li> <li>• Alcohol and Drugs</li> </ul> </li> <li>• Alcohol within limits</li> <li>• Not under influence</li> <li>• Unknown</li> </ul>
Who was at fault in the police officer’s opinion?	<ul style="list-style-type: none"> <li>• Pedestrian</li> <li>• Driver</li> <li>• Vehicle</li> <li>• Debris</li> <li>• Unclear</li> </ul>
What was the posted speed limit on the road segment where the crash occurred?	Numeric Entry (in mph) based on posted speed limit information in the report.
Officer comments	Other information from narrative text, e.g., Rain, dark clothing, unlit section, etc.

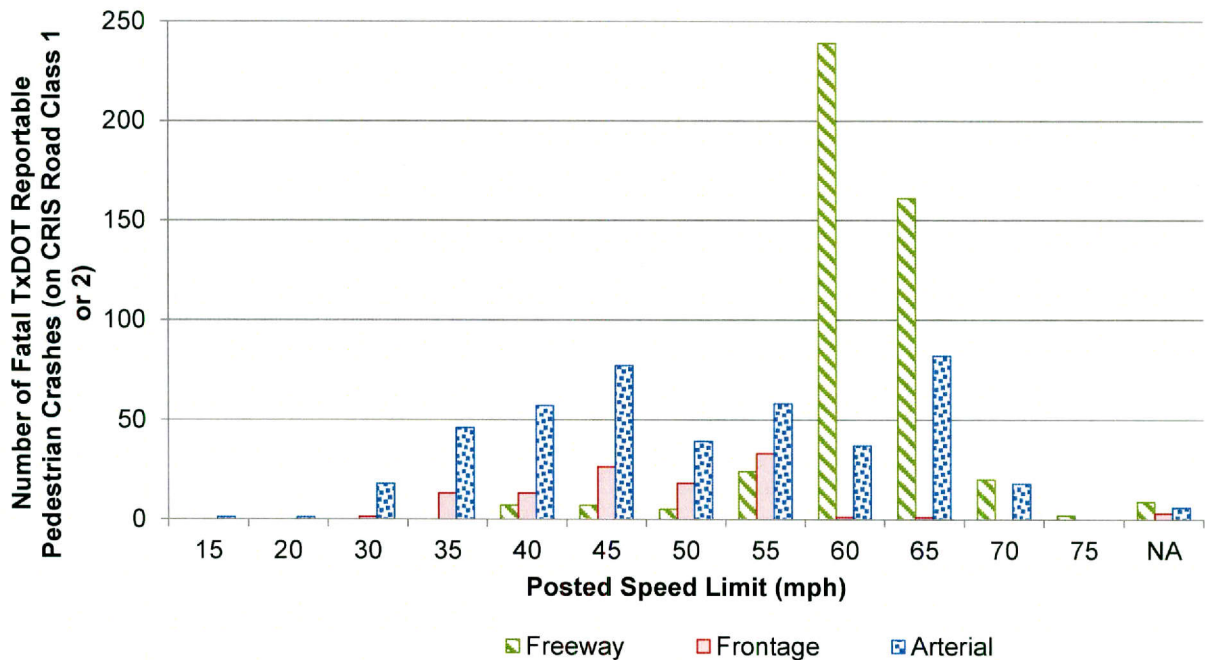
**Table 113. Distribution of Fatal TxDOT-Reportable Pedestrian Crashes by CRIS Road Class and Roadway Type (2007–2011).**

Road Class/Roadway Type	Freeway	Frontage	Arterial	Not Reviewed*	Total
Interstate	327	75	7 <sup>•</sup>	37	446
U.S. and State Highways	147	34	433	103	717
Farm to Market				266	266
County Road				103	103
City Street				691	691
Tollway				5	5
Other Roads				4	4
<b>Total</b>	<b>474</b>	<b>109</b>	<b>440</b>	<b>1209</b>	<b>2232</b>

\*Crashes in this column were not reviewed. Reason for not reviewing crashes on Interstates and U.S. and State highways is detailed in Table 111, and the reason for not reviewing crashes on the rest of the roadways was that it was assumed that these would not be access-controlled facilities.

• These seven crashes were coded as Interstates, but after review of the narrative and crash location (using CRIS latitude and longitude along with aerial photographs), it was determined that these were non-access-controlled arterials. These were either state spurs or business Interstates or city streets adjacent to an Interstate or had either an erroneous latitude/longitude entry or an erroneous functional system entry.

Figure 57 shows the distribution of fatal TxDOT-reportable pedestrian crashes on Interstates or U.S. and State highways by roadway type and posted speed limit (recorded by the officer). Speed limits noted by the officer and the roadway types identified by the researchers are in agreement. The crashes on lower speed locations of the freeway correspond to either exit or entrance ramps.



**Figure 57. Distribution of Fatal TxDOT-Reportable Pedestrian Crashes on Interstates or U.S. and State Highways by Roadway Type and Posted Speed Limit.**

## Roadway Part

Roadway part on which the crash occurred was determined from the crash narrative and sketch. The most common road part for fatal TxDOT-reportable pedestrian crashes on freeways, frontage roads, and arterials was the mainlines, followed by right shoulder (shown in Table 114). The third most common road part for these crashes on freeways was the exit ramp. For arterials, the third most common road part was the crosswalk (on mainlines).

**Table 114. Distribution of Fatal TxDOT-Reportable Pedestrian Crashes on Interstates or U.S. and State Highways by Road Part and Roadway Type.**

Road Part/ Roadway Type	Freeway		Frontage		Arterial		Total
	Frequency	Percentage	Frequency	Percentage	Frequency	Percentage	
Main lanes	351	74%	95	86%	369	84%	<b>814</b>
Right Shoulder	54	11%	11	10%	34	8%	<b>99</b>
Left Shoulder	12	3%	0	0%	1	0%	<b>13</b>
Entrance Ramp	19	4%	0	0%	0	0%	<b>19</b>
Exit Ramp	25	5%	0	1%	0	0%	<b>26</b>
Median	4	1%	0	0%	2	0%	<b>6</b>
HOV Lane	5	1%	0	0%	0	0%	<b>5</b>
Crosswalk on Main lanes	0	0%	1	1%	15	3%	<b>16</b>
TWLT Lane	0	0%	0	0%	6	1%	<b>6</b>
Off the Roadway	3	1%	1	1%	8	2%	<b>12</b>
Unknown	1	0%	1	1%	5	1%	<b>7</b>
<b>Total</b>	<b>474</b>	<b>100%</b>	<b>109</b>	<b>100%</b>	<b>440</b>	<b>100%</b>	<b>1023</b>

## Person Characteristics

In the 1023 fatal TxDOT-reportable pedestrian crashes on Interstates or U.S. and State highways, 3122 persons were involved. In the 474 freeway crashes, 1609 persons were involved, 737 of whom were drivers and 521 were pedestrians (shown in Table 115). The higher number of drivers indicates the prevalence of multi-vehicle collisions.

**Table 115. Distribution of Fatal TxDOT-Reportable Pedestrian Crashes on Interstates or U.S. and State Highways by Person Type and Roadway Type.**

Person Type	Freeway		Frontage		Arterial		Total
	Frequency	Percentage	Frequency	Percentage	Frequency	Percentage	
Driver	737	46%	125	44%	538	44%	<b>1400</b>
Passenger/ Occupant	345	21%	33	12%	213	17%	<b>591</b>
Pedestrian	521	32%	121	43%	474	38%	<b>1116</b>
Other	2	0%	2	1%	4	0%	<b>8</b>
Unknown	4	0%	0	0%	3	0%	<b>7</b>
<b>Total</b>	<b>1609</b>	<b>100%</b>	<b>281</b>	<b>100%</b>	<b>1232</b>	<b>100%</b>	<b>3122</b>

The age, gender, and ethnicity distribution of Texas' population for 2007 through 2011 was obtained from the Texas Department of State Health Services (181). The age groups chosen for this analysis are based on the age groups used in the U.S. Census data (181, 182). Table 116, Table 117, and Table 118 show the distribution of fatality rate (fatal TxDOT-reportable pedestrian crashes on freeways per 100,000 population) per year.

Age, gender, and ethnicity information is not available for drivers in 28 percent of the fatal TxDOT-reportable pedestrian crashes on freeways, indicating a considerable number of hit-and-run cases. There was not a code available in the CRIS database to identify such crashes, but from the review of the narrative text, researchers found that a large proportion of crashes were hit-and-run. This observation is in agreement with a 2011 *Houston Chronicle* article that quotes, "Capt. Roger Goralski, head of HPD's vehicular crimes division, said at least 45 percent of the pedestrians killed were found to have violated traffic laws and were at fault in their deaths. In another 21 percent of the deaths, police were unable to learn who drove the vehicle that fled the scene" (183).

Overall, pedestrians and drivers in the age group of 25–39 had the highest fatality rate, followed closely by those in the age group of 15–24 years. As observed in all traffic crashes, men are overrepresented in fatal pedestrian crashes on freeways, almost four times that of women. This might be an indication of a higher exposure of men to traffic conditions when compared to women, but more data need to be considered to make that conclusion.

No ethnicity information was available for pedestrians killed on freeways from 2007 through 2009. This might be due to the change in the format of CR-3 in 2010. The CR-3 form used from 2010 onward has a field to enter ethnicity of each person involved in the crash, whereas the earlier form only had a field for the driver's ethnicity. Based on the limited ethnicity information available, black drivers and pedestrians have the highest fatality rate.

**Table 116. Age Distribution of Fatality Rate (Fatal TxDOT-Reportable Pedestrian Crashes on Freeways Per 100,000 Population) Per Year.**

Age Group	2007		2008		2009		2010		2011		Average	
	Driver	Pedestrian	Driver	Pedestrian	Driver	Pedestrian	Driver	Pedestrian	Driver	Pedestrian	Driver	Pedestrian
<15	0.00	0.04	0.02	0.09	0.00	0.06	0.00	0.03	0.00	0.02	0.00	0.05
15–24	0.74	0.79	0.78	0.54	0.45	0.43	0.35	0.65	0.51	0.59	0.57	0.60
25–39	0.93	0.58	0.75	0.88	0.75	0.57	0.50	0.45	0.66	0.57	0.72	0.61
40–64	0.61	0.80	0.57	0.53	0.41	0.39	0.35	0.30	0.58	0.50	0.51	0.50
≥65	0.43	0.17	0.25	0.17	0.28	0.08	0.12	0.08	0.27	0.39	0.27	0.18
<b>Total (Including Unknown)</b>	<b>0.85</b>	<b>0.54</b>	<b>0.73</b>	<b>0.49</b>	<b>0.56</b>	<b>0.35</b>	<b>0.37</b>	<b>0.30</b>	<b>0.48</b>	<b>0.43</b>	<b>0.60</b>	<b>0.42</b>

**Table 117. Gender Distribution of Fatality Rate (Fatal TxDOT-Reportable Pedestrian Crashes on Freeways Per 100,000 Population) Per Year.**

Gender	2007		2008		2009		2010		2011		Average	
	Driver	Pedestrian	Driver	Pedestrian	Driver	Pedestrian	Driver	Pedestrian	Driver	Pedestrian	Driver	Pedestrian
Male	0.80	0.90	0.75	0.80	0.60	0.55	0.42	0.45	0.69	0.67	0.65	0.67
Female	0.31	0.18	0.23	0.16	0.19	0.15	0.17	0.16	0.17	0.18	0.21	0.17
<b>Total (Including Unknown)</b>	<b>0.85</b>	<b>0.54</b>	<b>0.73</b>	<b>0.49</b>	<b>0.56</b>	<b>0.35</b>	<b>0.37</b>	<b>0.30</b>	<b>0.48</b>	<b>0.43</b>	<b>0.60</b>	<b>0.42</b>

**Table 118. Ethnicity Distribution of Fatality Rate (Fatal TxDOT-Reportable Pedestrian Crashes on Freeways Per 100,000 Population) Per Year.**

Ethnicity	2007		2008		2009		2010		2011		Average	
	Driver	Pedestrian	Driver	Pedestrian	Driver	Pedestrian	Driver	Pedestrian	Driver	Pedestrian	Driver	Pedestrian
White	0.61	—	0.49	—	0.48	—	0.30	0.24	0.51	0.37	0.48	0.31
Hispanic	0.39	—	0.45	—	0.31	—	0.25	0.32	0.30	0.39	0.34	0.35
Black	0.93	—	0.64	—	0.42	—	0.40	0.43	0.67	0.77	0.61	0.60
Other	0.40	—	0.29	—	0.18	—	0.18	0.27	0.16	0.33	0.24	0.30
<b>Total (Including Unknown)</b>	<b>0.85</b>	<b>0.54</b>	<b>0.73</b>	<b>0.49</b>	<b>0.56</b>	<b>0.35</b>	<b>0.37</b>	<b>0.30</b>	<b>0.48</b>	<b>0.43</b>	<b>0.60</b>	<b>0.42</b>

### **Influence of Alcohol and/or Drugs**

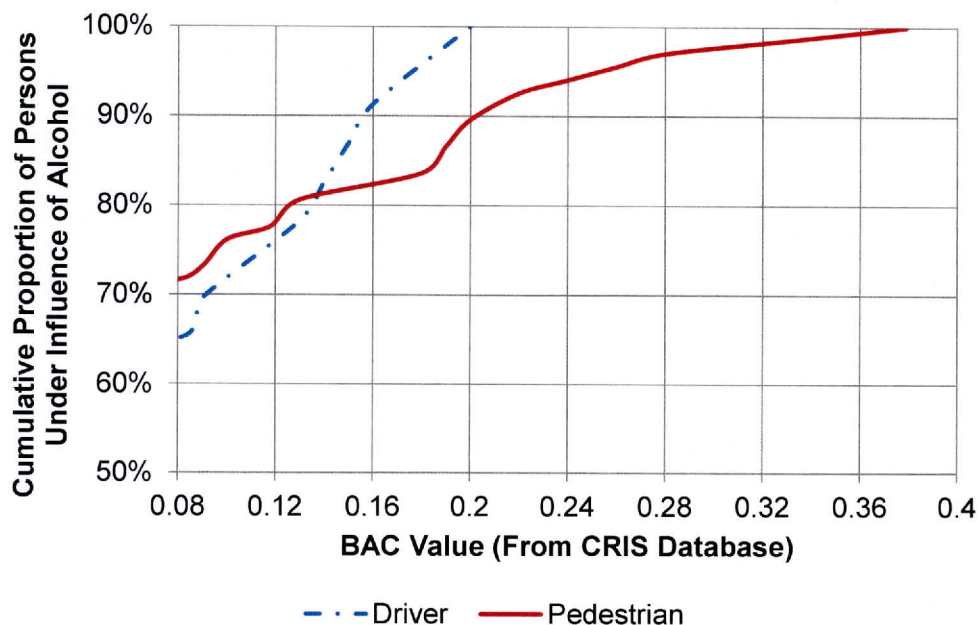
Information on influence of alcohol/drugs was not available in the CRIS database for at least one of the drivers in 97 percent (413/474) of the crashes and for at least one of the pedestrians in 70 percent (333/474) of the crashes. Also, the CRIS database had 16 drivers and 71 pedestrians with a positive alcohol test result and zero BAC level. To clarify all this, the crash reports were reviewed to determine if the pedestrian and/or the driver were under the influence of alcohol and/or drugs.

Influence of alcohol and/or drugs was determined from the alcohol/drug specimen result and the contributing factor fields. If “had been drinking” was noted as the contributing factor for the person involved in the crash, it was coded as alcohol for that person in our review. As shown in Table 119, alcohol/drug influence was determined for at least one of the drivers in 86 percent

(409/474) of the crashes and for at least one of the pedestrians in 89 percent (424/474) of the crashes, from the crash report review. Pedestrians were found to be under the influence in 28 percent of the crashes on freeways (132/474), whereas drivers were under the influence in 8 percent of the crashes (40/474). Figure 58 shows a comparison of BAC test results (from CRIS database) of pedestrians and drivers who were found to be under the influence of alcohol in the crash report review. The average BAC level reported (in the CRIS database) for pedestrians was 0.20, more than twice the legal limit, indicating high levels of intoxication.

**Table 119. Distribution of Pedestrians and Drivers under the Influence of Alcohol/Drug in TxDOT-Reportable Fatal Pedestrian Crashes on Freeways.**

		Driver								Total	
		Alcohol and/or Drugs		Alcohol <0.08 BAC		None		Unknown			
		Frequency	Percentage	Frequency	Percentage	Frequency	Percentage	Frequency	Percentage	Frequency	Percentage
<b>Pedestrian</b>	<b>Alcohol and/or Drugs</b>	7	1%	2	0.4%	107	23%	16	3%	<b>132</b>	<b>28%</b>
	<b>Alcohol &lt;0.08 BAC</b>	1	0.2%	0	0%	5	1%	1	0%	<b>7</b>	<b>1%</b>
	<b>None</b>	28	6%	1	0.2%	224	47%	32	7%	<b>285</b>	<b>60%</b>
	<b>Unknown</b>	4	1%	0	0%	30	6%	16	3%	<b>50</b>	<b>11%</b>
<b>Total</b>		<b>40</b>	<b>8%</b>	<b>3</b>	<b>1%</b>	<b>366</b>	<b>77%</b>	<b>65</b>	<b>14%</b>	<b>474</b>	<b>100%</b>



**Figure 58. Comparison of BAC Test Results (from CRIS Database) of Pedestrians and Drivers Who Were Found to be under the Influence of Alcohol in the Crash Report Review.**

### **Pedestrian Action at the Time of Crash**

What the pedestrian was doing immediately prior to the crash was identified from the narrative text and sketch. As shown in Table 120, almost half of the freeway crashes (232/474 or 49 percent) occurred when the pedestrian was trying to cross the roadway. Three percent of crashes on freeways (15/474) involved a pedestrian lying down. On freeways (as shown in Table 121), the most common situation for crashes is pedestrian crossing the main lanes (205/474 or 43 percent), followed by pedestrian standing on the main lanes (56/474 or 12 percent) or right shoulder (34/474 or 7 percent). However, it is unknown what the pedestrian was doing prior to the crash on freeway main lanes in 13 percent (47/351) of crashes. It was found that in 15 of these 47 crashes the pedestrian was under the influence of alcohol/drugs.



**Table 120. Distribution of Fatal TxDOT-Reportable Pedestrian Crashes (on CRIS Road Class 1 or 2) by Roadway Type and Pedestrian Action prior to Crash.**

Pedestrian Action/ Roadway Type	Freeway		Frontage		Arterial		Total
	Frequency	Percentage	Frequency	Percentage	Frequency	Percentage	
Crossing	232	49%	35	32%	232	53%	499
Standing	116	24%	17	16%	57	13%	190
Walking along Road	51	11%	36	33%	83	19%	170
Lying Down	15	3%	5	5%	21	5%	41
Unknown	60	13%	16	15%	47	11%	123
<b>Total</b>	<b>474</b>	<b>100%</b>	<b>109</b>	<b>100%</b>	<b>440</b>	<b>100%</b>	<b>1023</b>

**Table 121. Distribution of Fatal TxDOT-Reportable Pedestrian Crashes (on CRIS Road Class 1 or 2) on Roadway Type Freeway by Road Part and Pedestrian Action prior to Crash.**

Road Part/Pedestrian Action Prior to Crash On Freeway	Crossing	Standing	Walking along Road	Lying on Ground	Unknown	Total
Main lanes	205	56	33	10	47	351
Right Shoulder	1	34	10	1	8	54
Left Shoulder	0	12	0	0	0	12
Entrance Ramp	8	4	4	1	2	19
Exit Ramp	16	2	4	3	0	25
Median	0	3	0	0	1	4
HOV Lane	2	3	0	0	0	5
Off the Roadway	0	2	0	0	1	3
Unknown	0	0	0	0	1	1
<b>Total</b>	<b>232</b>	<b>116</b>	<b>51</b>	<b>15</b>	<b>60</b>	<b>474</b>

### Reason for Pedestrian at Crash Location

Researchers identified the reason for pedestrian presence at the crash location from the narrative text. As shown in Table 122, the reason for pedestrian presence at the crash location for 27 percent (127/474) of the fatal freeway crashes was associated with a vehicle (i.e., the pedestrian reached the crash location in a vehicle). However, for 68 percent (323/474) of the fatal freeway crashes the reason for pedestrian presence at the crash location was not stated in the crash narrative. Table 123 shows that 42 percent (200/474) of the fatal freeway crashes occurred when the pedestrian was crossing the freeway for reasons not stated in the crash narrative. Of the fatal crashes on freeways 26 percent (121/474) occurred when the pedestrian was out of his/her vehicle due to a stalled vehicle or a previous crash.

Table 124 shows the distribution of the 121 crashes in which the pedestrian was out of the vehicle due to a stalled vehicle or previous crash. Of these crashes 31 percent (37/121) occurred

when the pedestrian was standing on the main lanes, 25 percent (30/121) occurred when the pedestrian was standing on the right shoulder, and 15 percent (18/121) occurred when the pedestrian tried to cross the freeway main lanes.

**Table 122. Distribution of Fatal TxDOT-Reportable Pedestrian Crashes (on CRIS Road Class 1 or 2) by Reason for Pedestrian at Crash Location (as Related to a Vehicle) and Roadway Type.**

Reason for Pedestrian at Crash Location	Freeway		Frontage		Arterial		Total
	Frequency	Percentage	Frequency	Percentage	Frequency	Percentage	
Associated With a Vehicle	127	27%	18	17%	39	9%	184
Not Associated With a Vehicle	24	5%	9	8%	29	7%	62
Not Stated in Crash Narrative	323	68%	82	75%	372	85%	777
<b>Total</b>	<b>474</b>	<b>100%</b>	<b>109</b>	<b>100%</b>	<b>440</b>	<b>100%</b>	<b>1023</b>

**Table 123. Distribution of Fatal TxDOT-Reportable Pedestrian Crashes (on CRIS Road Class 1 or 2) by Reason for Pedestrian at Crash Location and Roadway Type.**

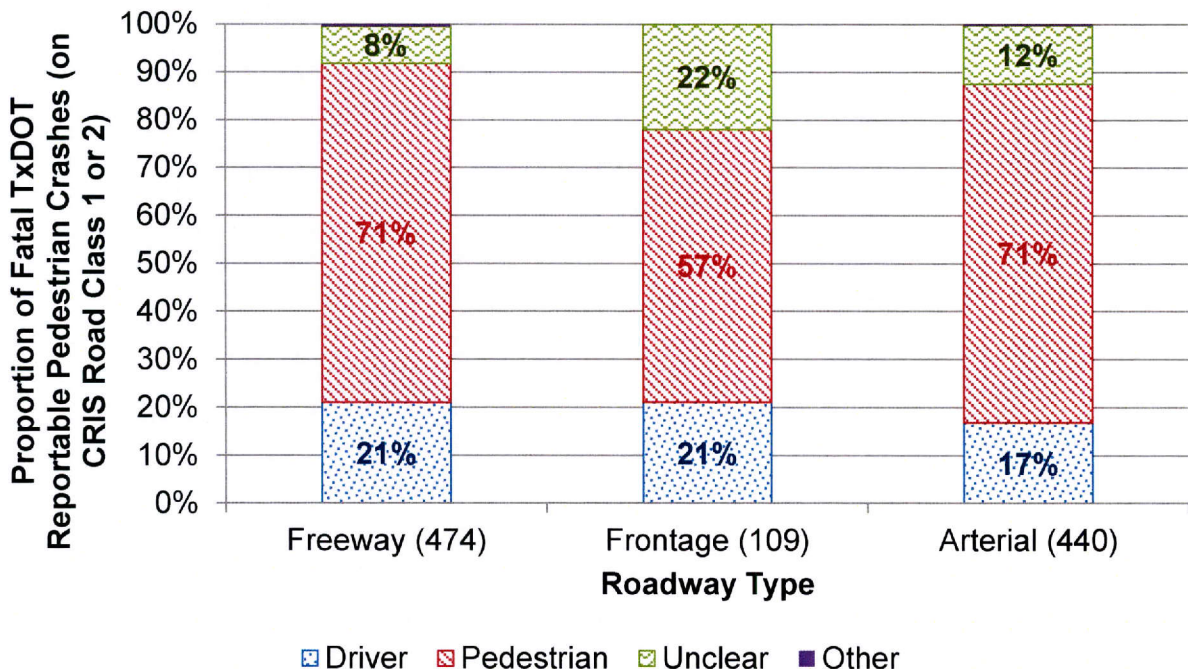
Reason for Pedestrian at Crash Location		Freeway		Frontage		Arterial		Total
		Frequency	Percentage	Frequency	Percentage	Frequency	Percentage	
Associated With a Vehicle	Stalled Vehicle	72	15%	10	9%	16	4%	<b>98</b>
	Previous Crash	49	10%	7	6%	17	4%	<b>73</b>
	Changing Seat Position	1	0.2%	0	0%	1	0.2%	<b>2</b>
	Jumping from Car	1	0.2%	1	1%	0	0%	<b>2</b>
	Taking Pictures	1	0.2%	0	0%	0	0%	<b>1</b>
	Retrieving Items from Road	3	1%	0	0%	5	1%	<b>8</b>
Not Associated With a Vehicle	Commuting	4	1%	3	3%	18	4%	<b>25</b>
	Working	10	2%	4	4%	5	1%	<b>19</b>
	Fleeing Police	5	1%	2	2%	1	0.2%	<b>8</b>
	Suicide	4	1%	0	0%	3	1%	<b>7</b>
	Unconscious	1	0.2%	0	0%	1	0.2%	<b>2</b>
	Jumping from Bridge	0	0%	0	0%	1	0.2%	<b>1</b>
Not Stated in Crash Narrative	Crossing Roadway	200	42%	29	27%	210	48%	<b>439</b>
	Standing in Traffic	13	3%	6	6%	19	4%	<b>38</b>
	Standing on Median or Shoulder or Off the Road	6	1%	1	1%	4	1%	<b>11</b>
	Walking Along Road or Lying Down in Traffic	42	9%	21	19%	72	16%	<b>135</b>
	Walking Along Road or Lying Down on Median or Shoulder or Off the Road	8	2%	9	8%	23	5%	<b>40</b>
	Unknown	54	11%	16	15%	44	10%	<b>114</b>
<b>Total</b>		<b>474</b>	<b>100%</b>	<b>109</b>	<b>100%</b>	<b>440</b>	<b>100%</b>	<b>1023</b>

**Table 124. Distribution of Fatal TxDOT-Reportable Pedestrian Crashes (on CRIS Road Class 1 or 2) on Roadway Type Freeway due to a Stalled Vehicle or a Previous Crash by Road Part and Pedestrian Action prior to Crash.**

Road Part/Pedestrian Action Prior to Crash on Freeway	Crossing	Standing	Walking along Road	Lying Down	Unknown	Total
Main lanes	18	37	4	2	1	<b>62</b>
Right Shoulder	0	30	3	0	1	<b>34</b>
Left Shoulder	0	8	0	0	0	<b>8</b>
Entrance Ramp	1	4	0	1	1	<b>7</b>
Exit Ramp	1	2	2	0	0	<b>5</b>
Median	0	3	0	0	0	<b>3</b>
HOV Lane	0	2	0	0	0	<b>2</b>
<b>Total</b>	<b>20</b>	<b>86</b>	<b>9</b>	<b>3</b>	<b>3</b>	<b>121</b>

**Unit at Fault**

The contributing factors information in the crash report and narrative text provided information on which involved person/unit was at fault, in the officer’s opinion. Figure 59 shows that on all three road types (freeway, frontage, and arterial), most crashes were coded as the pedestrian being at fault. In 71 percent (335/474) of the fatal freeway crashes, the pedestrian was coded as at fault; a third of these pedestrians were under the influence of alcohol and/or drugs.



**Figure 59. Proportion of Fatal TxDOT-Reportable Pedestrian Crashes on Interstates or U.S. and State Highways by Roadway Type and Unit at Fault in the Officer’s Opinion.**

## Weather and Light Conditions

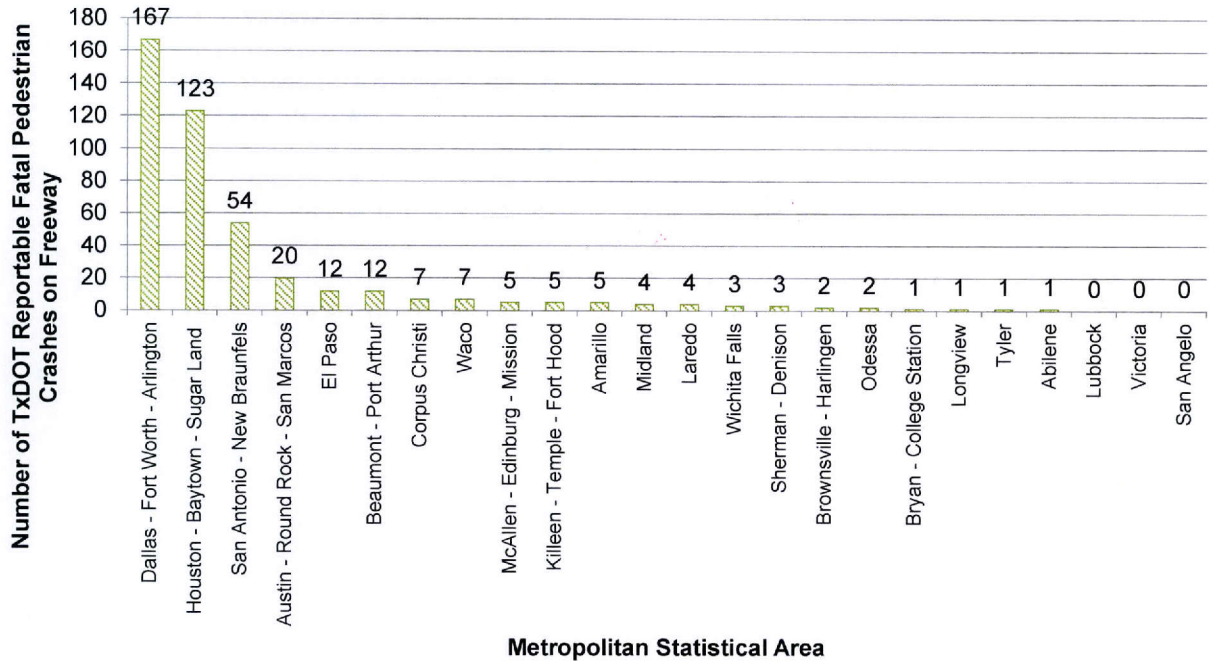
As shown in Table 125, 75 percent of the fatal TxDOT-reportable pedestrian crashes on freeways occurred in clear/cloudy weather under dark conditions. Over 80 percent (390/474) of crashes occurred in dark conditions, almost half of which were at locations with no lighting. Only 6 percent (30/474) of the fatal pedestrian crashes on freeways occurred when it was raining.

**Table 125. Distribution of Fatal TxDOT-Reportable Pedestrian Crashes on Freeways by Weather Condition and Light Condition.**

Weather Condition/ Light Condition	Dawn	Daylight	Dark, Not Lighted	Dark, Lighted	Dark, Unknown Lighting	Unknown	Blank	Total
Clear/Cloudy	9	65	165	186	7	1	2	<b>435</b>
Rain	0	3	10	16	1	0	0	<b>30</b>
Sleet/Hail/Snow	0	1	0	2	0	0	0	<b>3</b>
Fog	0	0	1	1	0	0	0	<b>2</b>
Unknown/Blank	0	0	0	1	0	3	0	<b>4</b>
<b>Total</b>	<b>9</b>	<b>69</b>	<b>176</b>	<b>206</b>	<b>8</b>	<b>4</b>	<b>2</b>	<b>474</b>

## Crash Location

Houston, Dallas, San Antonio, Fort Worth, and Austin are the TxDOT districts with the most fatal TxDOT-reportable pedestrian crashes on freeways. The metro areas with the most fatal TxDOT-reportable pedestrian crashes on freeways are Dallas-Fort Worth-Arlington, Houston-Baytown-Sugar Land, San Antonio-New Braunfels, Austin-Round Rock-San Marcos, and El Paso (as shown in Figure 60). Table 126 lists the 10 freeways with the most fatal TxDOT-reportable crashes by metro area. IH 45 in the Houston-Baytown-Sugar Land metro area has the highest number of fatal pedestrian crashes, followed by IH 35 in the Dallas-Fort Worth-Arlington metro area. However, looking at crashes per 100 miles of the freeway (shown in Table 127), IH 635 in Dallas has the highest crash rate, followed by IH 410 in the San Antonio-New Braunfels metro area. Figure 61 shows the distribution of alcohol/drug influence on pedestrians in the fatal TxDOT-reportable pedestrian crashes on these 10 freeways. US 59 has the highest proportion of crashes in which the pedestrian was under the influence, followed closely by IH 45.



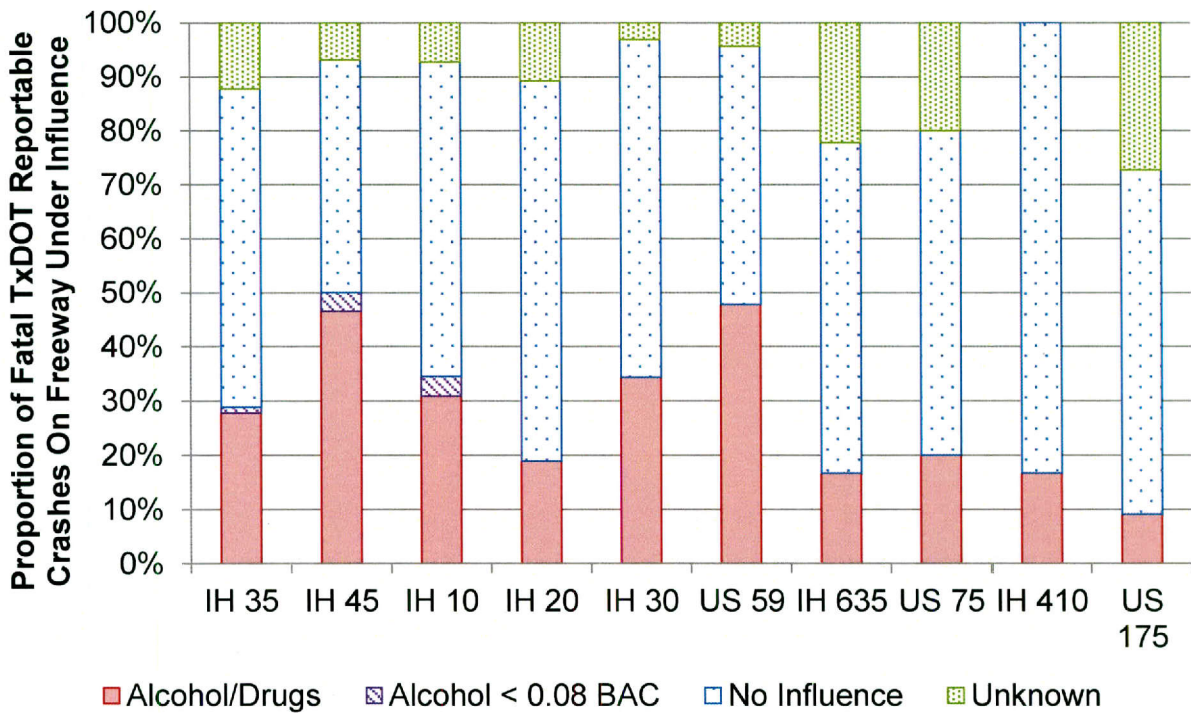
**Figure 60. Distribution of Fatal TxDOT-Reportable Pedestrian Crashes on Freeways by Texas Metropolitan Statistical Area.**

**Table 126. Distribution of Fatal TxDOT-Reportable Pedestrian Crashes on 10 Freeways with the Most Crashes by Texas Metropolitan Statistical Area.**

Highway System	Highway Number	Dallas-Fort Worth-Arlington	Houston-Baytown-Sugar Land	San Antonio-New Braunfels	Austin-Round Rock-San Marcos	El Paso	Other Metro Areas	Outside MSA	Total
IH	35	38	0	17	15	0	15	5	90
IH	45	5	47	0	0	0	0	6	58
IH	10	0	23	8	1	6	9	8	55
IH	20	22	0	0	0	0	8	7	37
IH	30	26	0	0	0	0	0	6	32
US	59	0	23	0	0	0	0	0	23
IH	635	18	0	0	0	0	0	0	18
US	75	13	0	0	0	0	2	0	15
IH	410	0	0	12	0	0	0	0	12
US	175	11	0	0	0	0	0	0	11

**Table 127. Distribution of Crashes Per 100 Miles on 10 Freeways with the Most Fatal TxDOT-Reportable Pedestrian Crashes in Texas.**

Highway System	IH	IH	IH	IH	US	IH	US	IH	IH	US
Highway Number	635 (184)	410 (185)	35 (186)	45 (187)	75 (188)	30 (189)	175 (190)	10 (191)	20 (192)	59 (193)
Total Length in Texas (miles)	37	50	407	285	76	224	111	878	635	612
Crashes per 100 miles	49	24	22	20	20	14	10	6	6	4



**Figure 61. Distribution of Fatal TxDOT-Reportable Pedestrian Crashes on 10 Freeways with the Most Crashes by Alcohol/Drug Influence on Pedestrian.**

As shown in Table 120 and Table 123, the most fatal crashes on freeways occurred when the pedestrian was crossing the freeway. The Houston-Baytown-Sugar Land metropolitan area has the most fatalities when the pedestrian tried to cross the freeway. The top 10 freeways with the most fatalities due to pedestrians crossing freeways are the same as that for pedestrian fatalities. IH 45 in the Houston-Baytown-Sugar Land metro area has the most fatal crashes when the pedestrian was crossing the freeway, followed by IH 35 in the Dallas-Fort Worth-Arlington metro area. However, looking at crashes per 100 miles of the freeway, IH 635 in Dallas has the highest crash rate when the pedestrian was crossing the freeway, followed by IH 410 in the San Antonio-New Braunfels metro area.

## DISCUSSION

Over the most recent 5-year period available (2007–2011), 2232 fatal TxDOT-reportable pedestrian crashes were identified in Texas. Of these crashes, 21 percent (474) were found to have occurred on access-controlled facilities. This is an alarmingly high number for an access-controlled facility where pedestrians are least expected. A review of the crash reports for these crashes provides some insight into the characteristics of these crashes.

On freeways, the most common situation for crashes is the pedestrian crossing the main lanes (74 percent, 205/474), followed by the pedestrian standing on the main lanes (12 percent, 56/474) or right shoulder (7 percent, 34/474). In 42 percent (200/474) of the fatal freeway crashes, the reason for the pedestrian crossing the freeway was not stated in the crash narrative. In 26 percent (121/474) of the fatal crashes on freeways, the pedestrian was out of his/her vehicle due to a stalled vehicle or a previous crash. A third of these 121 pedestrians were standing on the main lanes, a quarter were standing on the right shoulder, and 15 percent were crossing the freeway. In 71 percent (335/474) of the fatal freeway crashes, the pedestrian was coded as at fault; a third of these pedestrians were under the influence of alcohol and/or drugs. Of the fatal TxDOT-reportable pedestrian crashes on freeways 75 percent occurred in clear/cloudy weather under dark conditions; 82 percent (390/474) of the crashes occurred in dark conditions, almost half of which were at locations with no lighting.

Alcohol/drug influence was determined for at least one of the drivers in 86 percent (409/474) of the crashes and for at least one of the pedestrians in 89 percent (424/474) of the crashes, from the crash report review. Pedestrians were found to be under the influence in 28 percent of the crashes on freeways (132/474), whereas drivers were under the influence in 8 percent of the crashes (40/474). The average BAC level reported (in the CRIS database) for pedestrians was 0.20—more than twice the legal limit, indicating high levels of intoxication.

Dallas-Fort Worth-Arlington, Houston-Baytown-Sugar Land, San Antonio-New Braunfels, Austin-Round Rock-San Marcos, and El Paso are the metro areas with the highest number of fatal TxDOT-reportable pedestrian crashes on freeways. IH 45 in the Houston area has the most fatal pedestrian crashes, and IH 635 in Dallas has the highest crash rate (crashes per 100 miles of the freeway). US 59 has the highest proportion of crashes in which the pedestrian was under the influence, followed closely by IH 45.

In the 474 freeway crashes, 1609 persons were involved, 737 of whom were drivers and 521 of whom were pedestrians. The higher number of drivers indicates the prevalence of multi-vehicle collisions. Age, gender, and ethnicity information is not available for drivers in 28 percent of the fatal TxDOT-reportable pedestrian crashes on freeways, indicating a considerable number of hit-and-run cases. Overall, pedestrians and drivers in the age group of 25–39 had the highest fatality rate, followed closely by those in the age group of 15–24 years. As observed in all traffic crashes, men are overrepresented in fatal pedestrian crashes on freeways, almost four times that of women. No ethnicity information was available for pedestrians killed on freeways from 2007 through 2009. This might be due to the change in the format of CR-3 in 2010.



The fatal pedestrian crashes on freeways indicate situations where the drivers do not expect a pedestrian and were unable to see the pedestrian until it was too late. Influence of alcohol and/or drugs seems to be a major contributing factor to many pedestrians' poor judgment of crossing the freeway main lanes unsafely. However, a quarter of pedestrian crashes on freeways involved persons out of their vehicle due to a stalled vehicle or a previous crash.

## **SUMMARY**

This research effort provided an understanding of the high proportion of fatal pedestrian crashes occurring on Texas high-speed roads (i.e., TxDOT CRIS road class 1 and 2). The crash narrative review extracted information on the roadway type (i.e., freeway, arterial, or frontage road), road part, pedestrian action prior to crash, reason for pedestrian to be at the location, alcohol involvement, and unit at fault (according to the officer). The review of 1023 crash narratives showed that 21 percent (474/2232) of all fatal TxDOT-reportable pedestrian crashes occurred on access-controlled facilities, where pedestrians are least expected. Various crash and person characteristics associated with these fatal crashes are discussed, with some highlights being that 49 percent of these crashes occurred when the pedestrian attempted to cross the freeway for varied reasons, 82 percent of the freeway crashes occurred in dark conditions, the pedestrian was under the influence of alcohol/drugs in 28 percent of the crashes, and IH 635 in the Dallas has the highest number of crashes per 100 miles of freeway.



## CHAPTER 12

### ANALYSIS OF TEXAS PEDESTRIAN CRASHES USING CLASSIFICATION TREE MODELS

#### INTRODUCTION

The research team explored the TxDOT Crash Record Information System database to identify characteristics of crashes involving pedestrians in Texas. Using various identifiers in the crash, person, and unit CRIS files, the research team identified 34,620 TxDOT-reportable pedestrian crashes over the most recent 5-year period available (2007–2011). TxDOT-reportable crashes are the ones that occur on a traffic way and resulted in injury or death or \$1000 damage. The following are some key observations from the exploratory analysis:

- Pedestrian crashes were concentrated in urban areas with 85 percent of all pedestrian crashes and 70 percent of all fatal pedestrian crashes at non-rural locations.
- Most (53 percent) of the pedestrian crashes were either at or near an intersection/driveway.
- Most (89 percent) of the pedestrian crashes were found to have occurred on the roadway, while 2 percent occurred on the shoulder and 0.2 percent on the median.
- Most common group of pedestrian crashes (39 percent) was observed at locations with no traffic control device.
- Most (61 percent) pedestrian crashes occurred during daylight; however, most (73 percent) fatal pedestrian crashes occurred in the dark conditions.
- Most common age group among pedestrians (28 percent) and drivers (27 percent) involved was 41–64 years.
- Men were overrepresented in the pedestrian crash database with 61 percent of pedestrians and 50 percent of drivers (16 percent drivers had unknown gender) involved being male.

The objective of this analysis is to find the significant factors influencing severity of crashes involving pedestrians in Texas that may be difficult to identify using traditional exploratory analyses. The classification-regression tree (CRT) methodology, which is a popular data mining technique, is used in this analysis. CRT and other tree-based data mining techniques are widely applied in the areas of business, medicine, industry, and engineering and are gaining attention in the transportation safety area (194, 195, 196, 197, 198). According to Kashani and Mohaymany, “Decision tree models can identify and easily explain the complex patterns associated with crash risk and do not need to specify a functional form” (199, *pg. 1314*). Montella et al. state, “A simple goal of exploratory trees is to uncover the predictive structure of the problem and understanding which predictors and which interactions of predictors are the most significant to explain the response variable” (196, *pg. 108*).

## METHODOLOGY

The CRT model offers several advantages (7). Chang and Chien explain as follows:

“The first advantage of the CRT model is that there is no need to specify a functional form. In contrast, in the parametric regression model, if the functional form is not correctly specified, the relationship between injury likelihood and risk factors will be erroneously estimated. The second advantage of the CRT analysis is its graphic display of the analysis results, which allows straightforward interpretation of results. Traffic engineers can easily predict the injury likelihood of an accident simply by determining the value of splitters and tracing a path down the tree to a terminal node. In addition, outliers often present a serious problem for regression analysis because they can adversely affect the coefficient estimates. In the CRT model, outliers, which are isolated into a node, eventually are pruned away, resulting in no effect on splitting. The final advantage is that CRT effectively deals with large data sets containing a large number of explanatory variables and can produce useful results using only a few important variables.” (200, pg. 22)

The classification and regression tree framework is based on the algorithm first proposed by Breiman et al. in 1984 (201). They wrote, “When the value of the target variable is discrete, a classification tree is developed, whereas a regression tree is developed for the continuous target variable” (198, pg. 1021). In this study, the target variable is nominal (injury severity: fatal or non-fatal), and thus, the “classification tree” was developed. Kashani and Mahymany continue, “All the data is a node located at the top of the tree, called as the “root node”, which is then divided into two child nodes on the basis of an independent variable (splitter) that creates the best homogeneity. This process is continued repeatedly for each child node until all of the data in each node have the greatest possible homogeneity. This node is called a terminal node or “leaf” and has no branches. The most famous index for splitting of nominal data is the Gini index. For each tree created, the “goodness of fit” index, is calculated using the “misclassification error rate” or “misclassification cost.” To lessen the complexity of the maximal tree, which was created by over fitting the training data, and create simpler trees, pruning is performed according to the cost-complexity algorithm. An optimal tree is the one that has the least misclassification cost for the test data. Importance of each variable is calculated using the variable importance index and is scaled such that its summation is one.” (199, pg. 1361)

The equation used for the Gini index is:

$$\text{(Gini Index) } \text{Gini}(m) = 1 - \sum_{j=1}^j p^2(j|m) \quad [3]$$

$$P(j|m) = \frac{p(j,m)}{p(m)}, \quad p(j, m) = \frac{\pi(j)N_j(m)}{N_j}, \quad p(m) = \sum_{j=1}^j p(j, m)$$

Where,  $j$  is the number of target variables or classes,  $\pi(j)$  is the prior probability for class  $j$ ,  $p(j|m)$  is the conditional probability of a record being in class  $j$ , provided that it is in the node  $m$ ,  $N_j(m)$

is the number of records in class  $j$  of node  $m$ ,  $N_j$  is the number of records of class  $j$  in the root node, and Gini ( $m$ ) or the Gini index is the indication of impurity in node  $m$ . The prior probability shows the proportion of observations in each class in the population (199).

$$\text{Misclassification Error Rate} = \sum_{m=1}^M p(m)[\text{Gini}(m)] \quad [4]$$

Where,  $p(m)$  is the proportion of existing observations in the terminal node or leaf  $m$  (from all observations) and  $M$  is the number of terminal nodes (199).

$$\text{(Variable Importance Index) VIM}(x_j) = \sum_{t=1}^T \frac{n_t}{N} \Delta \text{Gini}(S(x_j, t)) \quad [5]$$

Where,  $\Delta \text{Gini}(S(x_j, t))$  is the reduction in the Gini index at node  $t$  that is achieved by splitting variable  $x_j$ ,  $\frac{n_t}{N}$  is the proportion of the observations in the data set that belong to node  $t$ ,  $T$  is the total number of nodes, and  $N$  is the total number of observations (199).

## DATA

Crash data used in this analysis are the same as the data set described in Chapter 9 (in-depth review of Texas pedestrian crashes). Pedestrian age and gender were added to this database from the CRIS person files described in Chapter 9. Table 128 lists the variables used in the analysis.

**Table 128. Variables Used in Analysis.**

Variable	Category	Code	Revised Code	Count	Percentage
Crash_ID	Unique ID number for each crash	—		34620	—
Crash_Fatal_Fl	Non-fatal	N		32388	94
	Fatal	Y		2232	6
Cmv_Involv_Fl	No commercial vehicle involved	N		33760	98
	Commercial vehicle involved	Y		860	2
Rpt_Outside_City_Limit_Fl	Within city limits	N		30882	89
	Outside city limits	Y		3738	11
Rpt_Road_Part_ID	Main/proper lane	1		30997	90
	Service/frontage road	2		1045	3
	Entrance/on ramp	3		114	0.3
	Exit/off ramp	4		126	0.4
	Connector/flyover	5		60	0.2
	Detour	6		6	0.02
	Other (explain in narrative)	7		2247	6
Road_Constr_Zone_Fl	Within construction zone	N		33822	98
	Outside construction zone	Y		798	2
Road_Constr_Zone_Wrkr_Fl	No construction worker involved	N		34254	99
	Construction worker involved	Y		366	1
At_Intrsect_Fl	Not at intersection	N		23267	67
	At intersection	Y		11353	33
Wthr_Cond_ID	Unknown	0	Un	154	0
	Clear/cloudy	1	Cl	19735	57
	Rain	2	Rn	1669	5
	Sleet/hail	3	Sw	34	0
	Snow	4	Sw	31	0
	Fog	5	Fg	105	0
	Blowing sand/snow	6	Ot	18	0
	Severe crosswinds	7	Ot	12	0
	Other (explain in narrative)	8	Ot	30	0
	Clear	11	Cl	10938	32
	Cloudy	12	Cl	1607	5
	(Missing Data)	(blank)	Un	287	1

**Table 128. Variables Used in Analysis. (Contd.).**

Variable	Category	Code	Revised Code	Count	Percentage
Wthr_Cond_Rev	Unknown/Missing Data	Un		441	1
	Clear/cloudy	Cl		32280	93
	Rain	Rn		1669	5
	Snow/sleet/hail	Sw		65	0
	Fog	Fg		105	0
	Blowing sand/snow/Severe crosswinds/Other	Ot		60	0
Light_Cond_ID	Unknown	0		137	0.4
	Daylight	1		21148	61
	Dawn	2		337	1
	Dark, not lighted	3		4570	13
	Dark, lighted	4		6960	20
	Dusk	5		624	2
	Dark, unknown lighting	6		334	1
	Other (explain in narrative)	8		23	0.1
	(Missing Data)	(blank)		487	1
Road_Algn_ID	Straight, level	1		29823	86
	Straight, grade	2		2296	7
	Straight, hillcrest	3		554	2
	Curve, level	4		826	2
	Curve, grade	5		376	1
	Curve, hillcrest	6		82	0.2
	Other (explain in narrative)	7		262	1
	Unknown	8		53	0.2
	Not reported	9		348	1
Surf_Cond_ID	Unknown	0		153	0.4
	Dry	1		31467	91
	Wet	2		2455	7
	Standing water	3		25	0.1
	Slush	5		9	0.03
	Ice	6		76	0.2
	Other (explain in narrative)	8		20	0.1
	Snow	9		21	0.1
	Sand, mud, dirt	10		80	0.2
	(Missing Data)	(blank)		314	1

**Table 128. Variables Used in Analysis. (Contd.).**

Variable	Category	Code	Revised Code	Count	Percentage
Traffic_Cntl_ID	No control or inoperative	0	N	1	0.003
	None	1	N	13351	39
	Inoperative (explain in narrative)	2	I	44	0.1
	Officer	3	B	164	0.5
	Flagman	4	B	110	0.3
	Signal light	5	I	5974	17
	Flashing red light	6	I	50	0.1
	Flashing yellow light	7	I	38	0.1
	Stop sign	8	I	4645	13
	Yield sign	9	I	185	1
	Warning sign	10	S	81	0.2
	Center stripe/divider	11	S	4933	14
	No passing zone	12	S	302	1
	RR gate/signal	13	I	18	0.1
	School zone	14	B	96	0.3
	Crosswalk	15	I	1237	4
	Bike lane	16	S	87	0.3
	Other (explain in narrative)	17	B	1039	3
	Marked lanes	20	S	1900	5
	Signal light with red light running camera	21	I	54	0.2
	(Missing Data)	(blank)		311	1
Traffic_Cntl_Rev	Intersection related	I		12245	35
	Segment related	S		7303	21
	Both	B		1409	4
	None/Missing Data	N		13663	39
Road_Cls_ID	Interstate	1		1867	5
	U.S. and State highways	2		5186	15
	Farm to market	3		2235	6
	County road	4		1743	5
	City street	5		23429	68
	Tollway	6		41	0.1
	Other roads	7		119	0.3
Road_Relat_ID	On roadway	1		30947	89
	Off roadway	2		2413	7
	Shoulder	3		571	2
	Median	4		83	0.2
	Not applicable	5		69	0.2
	Not reported	6		537	2
Rural_Fl	Non-rural	N		29524	85
	Rural	Y		5096	15



**Table 128. Variables Used in Analysis. (Contd.).**

Variable	Category	Code	Revised Code	Count	Percent
FHE_Collsn_ID	OMV – vehicle going straight	1	ST	24768	72
	OMV – vehicle turning right	2	RT	2342	7
	OMV – vehicle turning left	3	LT	4427	13
	OMV – vehicle backing	4	BK	1024	3
	OMV – other	5	O	189	1
	Angle – both going straight	10	ST	392	1
	Angle – one straight-one backing	11	BK	23	0.1
	Angle – one straight-one stopped	12	ST	27	0.1
	Angle – one straight-one right turn	13	RT	45	0.1
	Angle – one straight-one left turn	14	LT	74	0.2
	Angle – one right turn-one left turn	16	RL	2	0.01
	Angle – one right turn-one stopped	17	RT	2	0.01
	Angle – both left turn	18	LT	1	0.003
	Angle – one left turn-one stopped	19	LT	4	0.01
	SD – both going straight-rear end	20	ST	253	1
	SD – both going straight-sideswipe	21	ST	189	1
	SD – one straight-one stopped	22	ST	393	1
	SD – one straight-one right turn	23	RT	45	0.1
	SD – one straight-one left turn	24	LT	73	0.2
	SD – both right turn	25	RT	7	0.02
	SD – both left turn	28	LT	6	0.02
	SD – one left turn-one stopped	29	LT	1	0.003
	OD – both going straight	30	ST	55	0.2
	OD – one straight-one backing	31	BK	12	0.03
	OD – one straight-one stopped	32	ST	20	0.1
	OD – one straight-one right turn	33	RT	2	0.01
	OD – one straight-one left turn	34	LT	204	1
	OD – one backing-one stopped	35	BK	10	0.03
	OD – one right turn-one left turn	36	RL	3	0.01
	OD – one left turn-one stopped	39	LT	1	0.003
OD – one enter or leave parking space-one stopped	43	O	1	0.003	
Other	46	O	1	0.003	
Not reported	48	N	24	0.1	
FHE_Collsn_Rev	At least one vehicle going straight	ST		26097	75
	At least one vehicle turning right	RT		2443	7
	At least one vehicle turning left	LT		4791	14
	One vehicle turning left and one vehicle turning right	RL		5	0
	At least one vehicle backing	BK		1069	3
	Other	O		191	1
	Not reported	N		24	0.1

**Table 128. Variables Used in Analysis. (Contd.).**

Variable	Category	Code	Revised Code	Count	Percent
Hour	Hour of day	0-23		34620	—
Othr_Factr_ID	Lost control or skidded (icy or slick road, etc.)	1	LC	88	0
	Passenger interfered with driver	2	DI	4	0
	Attention diverted from driving	3	DI	99	0
	Open door or object projecting from vehicle	4	LC	81	0
	Foot slipped off brake or clutch	5	LC	2	0
	Vehicle passing or attempting to pass on left	7	CH	46	0
	Vehicle passing or attempting to pass on right	8	CH	14	0
	Vehicle changing lanes	9	CH	185	1
	One vehicle parked improper location	10	PRK	62	0
	One vehicle forward from parking	11	PRK	27	0
	One vehicle backward from parking	12	PRK	60	0
	One vehicle entering driveway	13	DWY	627	2
	One vehicle leaving driveway	14	DWY	2297	7
	Vision obstructed by standing or parked vehicle	16	VO	60	0
	Vision obstructed by moving vehicle	17	VO	18	0
	Vision obstructed by embankment or ledge	18	VO	1	0
	Vision obstructed by headlight or sun glare	21	VO	150	0
	Vision obstructed by hillcrest	22	VO	1	0
	Vision obstructed by trees, shrubs, weeds, etc.	23	VO	3	0
	Vision obstructed by other visual obstructions	24	VO	67	0
	Swerved or veered – reason not specified	25	SW	7	0
	Swerved or veered – for off., flagman, or trf. ctrl. device	27	SW	2	0
	Swerved or veered – avoiding pedestrian, pedalcyclist, etc. in road	28	SW	110	0
	Swerved or veered – avoiding animal in road	29	SW	18	0
	Swerved or veered – avoiding object in road	30	SW	4	0
	Swerved or veered – avoid veh. stopped or moving slowly in trf. ln.	31	SW	31	0
	Swerved or veered – avoiding vehicle entering road	32	SW	47	0
	Swerved or veered – avoiding veh. from opp. dir. in wrong lane	33	SW	22	0
	Swerved or veered – avoiding previous accident	34	SW	10	0
	Swerved or veered – avoiding vehicle passing, changing lanes	35	SW	42	0

**Table 128. Variables Used in Analysis. (Contd.).**

Variable	Category	Code	Revised Code	Count	Percent
Othr_Factr_ID	Slowing/stopping – reason not specified	36	SL	15	0
	Slowing/stopping – for surface or visibility	37	SL	1	0
	Slowing/stopping – for off., flagman, or trf. ctrl.	38	SL	125	0
	Slowing/stopping – for pedestrian, pedalcyclist, etc. in road	39	SL	89	0
	Slowing/stopping – for animal in road	40	SL	3	0
	Slowing/stopping – for object in road	41	SL	3	0
	Slowing/stopping – for traffic	42	SL	113	0
	Slowing/stopping – for vehicle entering road	43	SL	3	0
	Slowing/stopping – for vehicle from opposite direction in wrong lane	44	SL	9	0
	Slowing/stopping – to avoid previous accident	45	SL	13	0
	Slowing/stopping – to make right turn	46	SL	24	0
	Slowing/stopping – to make left turn	47	SL	26	0
	School bus related crash	48	SB	115	0
	Construction – within posted road const. zone (not related to crash)	49	CO	544	2
	Construction – within posted road construction zone (related to crash)	50	CO	220	1
	Construction – in other const. main. area (not related to crash)	51	CO	19	0
	Construction – in other construction maintenance area (related to crash)	52	CO	29	0
	Crash occurred on a beach	53	BE	16	0
	Not applicable	54	N	29051	84
	Not reported	55	N	17	0
Othr_Factr_Rev	Construction zone	CO		812	2
	School bus related	SB		115	0
	Driveway	DWY		2924	8
	Parking related	PRK		149	0
	Crash occurred on a beach	BE		16	0
	Attempting to change lanes	CH		245	1
	Slowing/Stopping	SL		424	1
	Swerved or veered	SW		293	1
	Driver vision obstructed	VO		300	1
	Driver inattention or distracted	DI		103	0
	Lost control or skidded	LC		171	0
	Not applicable or not reported	N		29068	84

**Table 128. Variables Used in Analysis. (Contd.).**

Variable	Category	Code	Revised Code	Count	Percent
Hwy_Dsgn_Lane_ID	One-way pair	0		224	1
	One-way	1		16	0
	Two-way	2		4908	14
	Boulevard	3		1671	5
	Expressway	4		198	1
	Freeway	5		2499	7
	(Missing Data)	(blank)		25104	73
Hwy_Dsgn_Hrt_ID	No HOV, no railway, not toll road	0		9509	27
	Toll road	3		7	0
	(Missing Data)	(blank)		25104	73
Hp_Shldr_Left	Left shoulder width	0-24		9516	28
	(Missing Data)	(blank)		25104	72
Hp_Shldr_Right	Right shoulder width	0-24		9516	28
	(Missing Data)	(blank)		25104	72
Hp_Median_Width	Median width	0-469		9516	28
	(Missing Data)	(blank)		25104	72
Nbr_Of_Lane	Number of lanes	2-12		9516	28
	(Missing Data)	(blank)		25104	72
Shldr_Type_Left_ID	None	1		3550	10
	Surfaced	2		5507	16
	Stabilized-surfaced with flex	3		232	1
	Combination-surface/stabilized	4		26	0
	Earth-with or without turf	5		201	1
	(Missing Data)	(blank)		25104	73
Shldr_Type_Right_ID	None	1		3068	9
	Surfaced	2		5982	17
	Stabilized – surfaced with flex	3		251	1
	Combination – surface/stabilized	4		28	0
	Earth – with or without turf	5		187	1
	(Missing Data)	(blank)		25104	73
Median_Type_ID	No median	0		4925	14
	Curbed	1		1093	3
	Positive barrier	2		1990	6
	Unprotected	3		1279	4
	One-way pair	4		229	1
	(Missing Data)	(blank)		25104	73

**Table 128. Variables Used in Analysis. (Contd.).**

Variable	Category	Code	Revised Code	Count	Percent
Func_Sys_ID	Rural Interstate	1		172	0
	Rural prin arterial	2		364	1
	Rural minor arterial	6		349	1
	Rural major coll	7		499	1
	Rural minor coll	8		88	0
	Rural local	9		1	0
	Urban prin arterial (IH)	11		1480	4
	Urban prin arterial (other freeway)	12		1165	3
	Urban prin arterial (other)	14		4272	12
	Urban minor arterial	16		961	3
	Urban collector	17		165	0
Adt_Curnt_Amt	Accident year AADT	0-323,090		9516	28
	(Missing Data)	(blank)		25104	73
Trk_Aadt_Pct	Accident year truck AADT percentage	0-80.7		9516	28
	(Missing Data)	(blank)		25104	73
Day_of_Week	Sunday	Sun		3955	11
	Monday	Mon		4799	14
	Tuesday	Tue		5027	15
	Wednesday	Wed		5025	15
	Thursday	Thu		5094	15
	Friday	Fri		5755	17
	Saturday	Sat		4965	14
Month	Month of year	1-12		34620	—
Driver Gender	Unknown	0		4984	14
	Male	1		17617	51
	Female	2		11838	34
	(Missing Data)	(blank)		181	1
Driver Age	Age of one of the driver involved	0-100		34439	99.5
	(Missing Data)	(blank)		181	0.5
Pedestrian Gender	Unknown	0		244	1
	Male	1		13478	39
	Female	2		8294	24
	(Missing Data)	(blank)		12604	36
Pedestrian Age	Age of one of the pedestrian involved	0-99		22016	64
	(Missing Data)	(blank)		12604	36

## ANALYSIS

The response variable assessed in this analysis was crash severity, which is defined as the level of injury sustained by the most severely injured person involved in the crash. The crash severity variable used for developing the classification tree for this analysis was categorized as either fatal or non-fatal. The analysis was performed using commercially available statistical analysis software (202). The tree depth was restricted to five levels, and impurity was measured with the Gini index. Minimum change in impurity improvement was set at 0.0001. Seventy percent of the data were randomly assigned to train the model, and the remaining 30 percent were allocated to the test. The tree was pruned to avoid over fitting.

Kashani and Mahymany wrote,

“In the studies related to crash severity or injury severity, because the proportion of fatality data is generally less than the data on property damage only or injury, its prediction accuracy decreases. To solve this problem, in cases where levels of target variables have an unbalanced proportion but the same prediction accuracy importance, it has been suggested to set equal prior probabilities such that the ones that have a lower proportion may also be taken into consideration in predictions (Steinberg and Golovnya, 2007). Although the overall accuracy of the model decreases, the prediction accuracy of the data with the least proportion increases, which is more important for decision makers in most cases.” (199, pg. 1318)

In the data set used for this analysis, the number of non-fatal crashes was almost 15 times that of fatal crashes (32,388 vs. 2232), and the overall prediction accuracy for the test sample was 93.5 percent, whereas the prediction accuracy for fatal crashes was only 10.9 percent. Compared to these numbers, Table 129 shows that with using equal prior probabilities across all categories, the overall prediction accuracy of the model (for the training and the test data) decreased slightly, but the prediction accuracy for fatal crashes improved tremendously (74.3 percent vs. 10.9 percent). Table 130 shows the misclassification costs and Table 131 shows the risk estimate for the model.

**Table 129. Prediction Performance for the CRT Model.**

Sample	Observed Crash Severity	Predicted Crash Severity		
		Non-Fatal	Fatal	Percent Correct
Training	Non-Fatal	17826	4912	78.4%
	Fatal	359	1224	77.3%
	Overall Percentage	74.8%	25.2%	78.3%
Test	Non-Fatal	7575	2075	78.5%
	Fatal	167	482	74.3%
	Overall Percentage	75.2%	24.8%	78.2%

**Table 130. Misclassification Costs for the CRT Model.**

Observed	Predicted	
	N	Y
N	0.000	1.000
Y	1.000	0.000

**Table 131. Risk Estimate of the Model.**

Sample	Estimate	Std. Error
Training	0.221	0.005
Test	0.236	0.009

## RESULTS

Table 132 provides a summary of the classification tree model and shows the results. The resulting classification tree has eleven terminal nodes and five levels. Table 133 shows the relative importance of the independent variables in the model. The table shows that road class and light condition are the most important variables in predicting crash severity. The classification tree generated (Figure 62) shows that light condition, road class, traffic control, right shoulder width, involvement of a commercial vehicle, pedestrian age, and the manner in which the vehicle(s) were moving prior to the first harmful event are critical in classifying the injury severity of pedestrian crashes. For better readability, Figure 63 and Figure 64 show the enlarged left and right parts of the classification tree generated.

**Table 132. Model Summary.**

<b>Specifications</b>	Growing Method	CRT
	Impurity Measure	Gini
	Minimum Change in Improvement	0.0001
	Dependent Variable	Crash_Fatal_Fl
	Independent Variables	Cmv_Involv_Fl, Rpt_Outside_City_Limit_Fl, Rpt_Road_Part_ID, Road_Constr_Zone_Fl, Road_Constr_Zone_Wrkr_Fl, At_Intrsect_Fl, Wthr_Cond_Rev, Light_Cond_ID, Road_Algn_ID, Surf_Cond_ID, Traffic_Cntl_Rev, FHE_Collsn_Rev, Othr_Factr_Rev, Road_Cls_ID, Road_Relat_ID, Rural_Fl, Day_of_Week, Month, Hour, DriverAge, DriverGender, PedestrianAge, PedestrianGender, Hwy_Dsgn_Lane_ID, Hwy_Dsgn_Hrt_ID, Hp_Shldr_Left, Hp_Shldr_Right, Hp_Median_Width, Nbr_Of_Lane, Shldr_Type_Left_ID, Shldr_Type_Right_ID, Median_Type_ID, Adt_Curnt_Amt, Trk_Aadt_Pct
	Validation	Split Sample: 70% for training and 30% for test
	Maximum Tree Depth	5
	Minimum Cases in Parent Node	100
	Minimum Cases in Child Node	50
	<b>Results</b>	Independent Variables Included
Number of Nodes		21
Number of Terminal Nodes		11
Depth		4



**Table 133. Independent Variable Importance.**

<b>Independent Variable</b>	<b>Importance</b>	<b>Normalized Importance</b>
Road_Cls_ID	0.122	100.0%
Light_Cond_ID	0.102	83.4%
Traffic_Cntl_Rev	0.097	79.0%
FHE_Collsn_Rev	0.059	48.2%
PedestrianAge	0.053	43.4%
At_Intrset_Fl	0.045	36.5%
Othr_Factr_Rev	0.015	12.2%
Median_Type_ID	0.013	10.6%
Trk_Aadt_Pct	0.013	10.3%
Hour	0.011	9.3%
Road_Relat_ID	0.010	8.5%
Hwy_Dsgn_Lane_ID	0.010	8.5%
Hp_Shldr_Right	0.010	7.8%
DriverGender	0.009	7.6%
Rpt_Road_Part_ID	0.009	7.2%
Rpt_Outside_City_Limit_Fl	0.008	6.6%
Cmv_Involv_Fl	0.008	6.5%
Hp_Shldr_Left	0.008	6.1%
Hp_Median_Width	0.006	4.6%
Shldr_Type_Right_ID	0.005	4.0%
PedestrianGender	0.004	3.3%
Rural_Fl	0.004	3.1%
DriverAge	0.003	2.8%
Adt_Currt_Amt	0.003	2.8%
Shldr_Type_Left_ID	0.003	2.8%
Road_Algn_ID	0.003	2.6%
Day_of_Week	0.002	1.7%
Nbr_Of_Lane	0.001	1.1%
Surf_Cond_ID	0.001	0.7%
Road_Constr_Zone_Wrkr_Fl	0.001	0.6%
Wthr_Cond_Rev	0.001	0.4%
Road_Constr_Zone_Fl	0.000	0.3%
Hwy_Dsgn_Hrt_ID	0.000	0.3%
Month	6.875E-005	0.1%

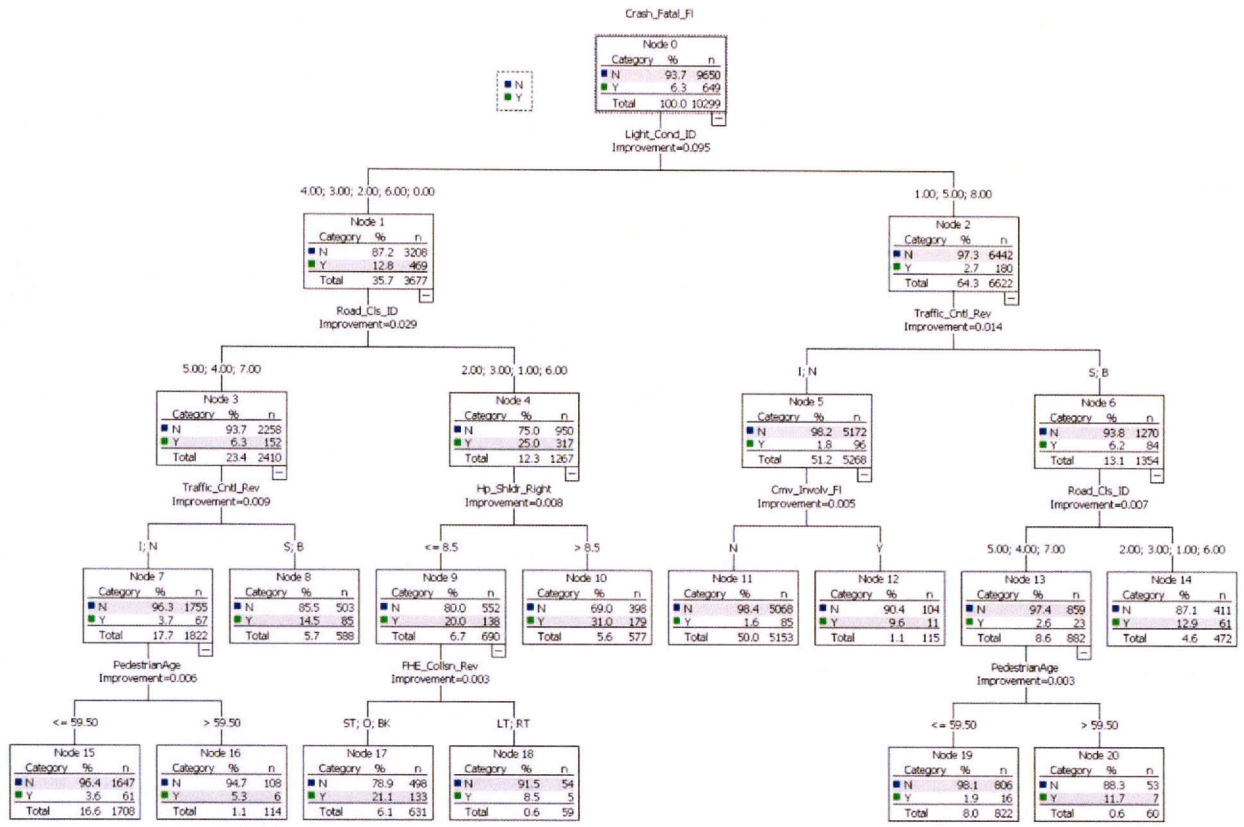


Figure 62. Classification Tree.

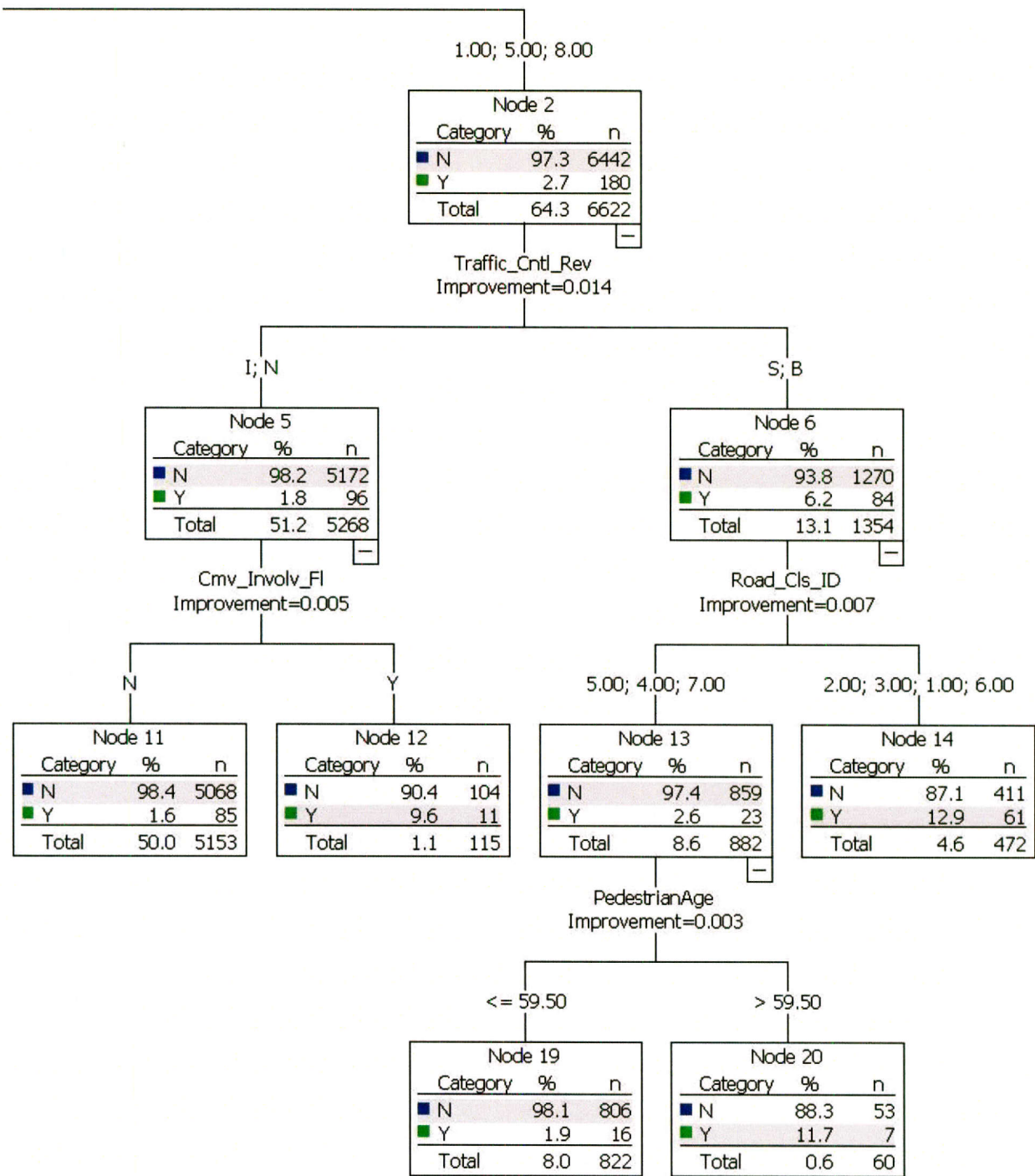
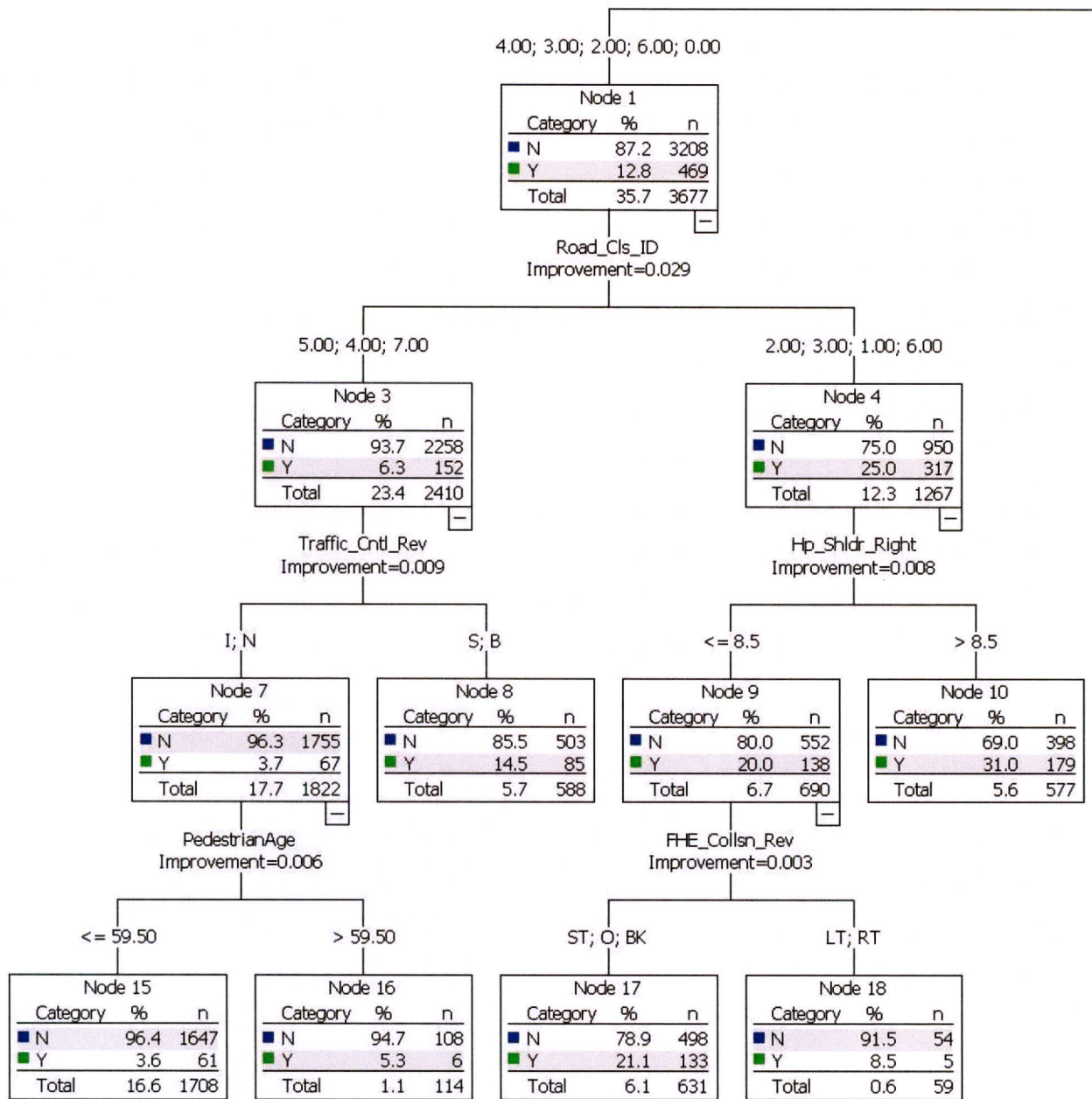


Figure 63. Right Branch of the Classification Tree.



**Figure 64. Left Branch of the Classification Tree.**

The initial split at node 0 of the classification tree is based on the variable of light condition, which implies that light condition is the best variable to classify and predict pedestrian crash severity (fatal versus non-fatal). More (64 percent) pedestrian crashes are predicted to occur in daylight, whereas a higher proportion of fatal crashes are predicted to occur in dark conditions (13 percent vs. 3 percent, Node 1 vs. Node 2). Traffic control, road class, and pedestrian age are selected to be the splitters more than once, implying that these variables have multiple effects on the crash severity outcome.

## **Non-Fatal Pedestrian Crashes**

Most non-fatal pedestrian crashes are predicted to occur in daylight conditions (Node 2), at locations with either no traffic control device or intersection-related traffic control devices such as a stop sign (Node 5), mostly involving non-commercial vehicles (Node 11). Non-fatal pedestrian crashes in daylight conditions that occur at locations with segment-related traffic control devices like a warning sign, and other traffic controls like a flagman, are predicted to occur more on city streets, county roads, and other low-speed roads (Node 13), mostly involving pedestrians younger than 60 years.

Most non-fatal pedestrian crashes in dark conditions are predicted to occur on city streets, county roads, and other lower speed roadways (Node 3) at locations with either no traffic control device or an intersection-related traffic control device like a signal (Node 7), mostly involving pedestrians younger than 60 years (Node 15). Most non-fatal pedestrian crashes in dark conditions on high-speed roadways such as Interstates are predicted to occur on segments with less than 8.5 ft of right shoulder width (Node 9) when one of the vehicles involved is either going straight or backing (Node 17).

## **Fatal Pedestrian Crashes**

A higher proportion of fatal pedestrian crashes are predicted to occur in dark conditions (Node 1) on high-speed roadways such as Interstates (Node 4) with more than 8.5 ft right shoulder width (Node 10). On high-speed roadways including Interstates with less than 8.5 ft right shoulder width, a higher proportion of fatal pedestrian crashes in dark conditions is predicted to occur when one of the vehicles involved is either going straight or backing (Node 17). On city streets, county roads, and other lower speed roads in dark conditions, a higher proportion of fatal pedestrian crashes are predicted at locations with segment-related traffic control devices such as a warning sign, and other traffic controls like a flagman (Node 8). Also, a higher proportion of pedestrians older than 60 years (Node 16) are predicted to be involved in fatal crashes on city streets with either no traffic control device or intersection-related traffic control devices like a stop sign in dark conditions.

A high proportion of fatal pedestrian crashes in daylight conditions are predicted on high-speed roads such as Interstates at locations with segment-related traffic control devices like a warning sign, and other traffic controls like a flagman (Node 14). Also, a higher proportion of pedestrians older than 60 years (Node 20) are predicted to be involved in fatal crashes on city streets with segment-related traffic control devices like a warning sign, and other traffic controls like a flagman in daylight conditions. At locations with intersection-related traffic control devices like a stop sign, a higher proportion of fatal pedestrian crashes in daylight conditions are predicted to involve a commercial vehicle (Node 12).

## **Overview**

Half of the pedestrian crashes are predicted to occur in daylight conditions at locations with either no traffic control device or intersection-related traffic control devices like a stop sign (Node 11) and involve non-commercial vehicles. Almost a third of the fatal pedestrian crashes

are predicted to occur on high-speed roadways (i.e., U.S. and State highways, FM roads, Interstates, and tollways) with more than 8.5 ft right shoulder width (Node 10) in dark conditions. This outcome supports the work described in Chapter 11 on fatal pedestrian crashes on freeways and other controlled-access facilities.

## DISCUSSION

Researchers explored the TxDOT Crash Record Information System database and identified 34,620 TxDOT-reportable pedestrian crashes over the most recent 5-year period available (2007–2011). The classification tree developed with the data indicates that the following variables are critical in classifying the injury severity of pedestrian crashes:

- Light condition.
- Road class.
- Traffic control.
- Right shoulder width.
- Involvement of a commercial vehicle.
- Pedestrian age.
- Manner in which the vehicle(s) were moving prior to the first harmful event.

The results indicated that the probability of pedestrian crashes is higher in daylight conditions; however, the severity of the crash is more important in dark conditions. When a pedestrian is struck at night, he or she is four times more likely to be killed when compared to daylight conditions (13 percent vs. 3 percent, Node 2 vs. Node 1). This result is in agreement with a study on pedestrian crashes in North Carolina that found that dark conditions (with and without streetlights) significantly increase the probability of fatal injury for pedestrians (203). This could be a reflection of higher speeds at night, along with greater difficulty in detecting pedestrians in dark conditions; hence, the driver is not able to reduce the speed in time before hitting the pedestrian.

Kim et al. (203) also found that freeway, U.S. route, and State route increased the probability of fatal injury in pedestrian crashes, compared with local city streets. The results from this classification tree analysis also show that under all dark conditions and daylight conditions at locations with segment-related traffic control devices such as a warning sign, the probability of pedestrian crashes is higher on city streets, county roads, and other lower speed roads, whereas the severity of the crash is greater on higher speed roads, i.e., Interstates, U.S. and State highways, FM roads, and tollways (25 percent vs. 6 percent, Node 4 vs. Node 3, and 13 percent vs. 3 percent, Node 14 vs. Node 13).

The results show that younger ( $\leq 60$  years) pedestrians are involved in more crashes, whereas older ( $> 60$  years) pedestrians are more likely to be killed when struck by a vehicle (5 percent vs. 4 percent, Node 16 vs. Node 15, and 12 percent vs. 2 percent, Node 20 vs. Node 19). As expected, Kim et al. also found that older pedestrians are more likely to sustain greater injury than younger pedestrians (203, 204), and Holubowycz found the greatest fatality rates in pedestrians 75 years or older (205).

Commercial vehicle involvement in a pedestrian crash is associated with a greater probability of pedestrian fatality (10 percent vs. 2 percent, Node 12 vs. Node 11). This is obviously attributed to commercial vehicles' larger weight, longer stopping distances, higher bumper height, and blunt geometry, which have also been documented in previous studies (203, 204, 206, 207).

Locations with no traffic control device or intersection-related traffic control devices (e.g., signals) are found to be associated with a greater number of pedestrian crashes; however, locations with segment traffic control devices (e.g., warning sign or flagger) or both traffic control devices (i.e., officer, flagman, school zone) are associated with a higher proportion of fatal pedestrian crashes (15 percent vs. 4 percent, Node 8 vs. Node 7, and 6 percent vs. 2 percent, Node 6 vs. Node 5). This result is intuitive because more pedestrians are expected to be present at intersections and the vehicle speeds are relatively lower, when compared to mid-segment.

The results also show that on high-speed roads, more crashes are expected at locations with right shoulder width less than 8.5 ft (Node 9), when one of the vehicles involved is either going straight or backing (Node 17). However, a higher proportion of fatal crashes on high-speed roads are at locations with right shoulder width more than 8.5 ft.

Overall, the results of this study, which used classification trees, were intuitive and consistent with the results of previous studies that used other analytical techniques, such as probabilistic models of crash injury severity.

## **SUMMARY**

This research effort uses the classification and regression tree methodology to identify significant factors influencing severity of a crash involving pedestrians in Texas. Light condition, road class, traffic control, right shoulder width, involvement of a commercial vehicle, pedestrian age, and the manner in which the vehicles were moving prior to the first harmful event are found to be critical in classifying the injury severity of pedestrian crashes.





## CHAPTER 13

### SUMMARY AND CONCLUSIONS

#### SUMMARY OF RESEARCH

For Texas, the average number of pedestrian fatalities over the most recent 5-year period available (2007–2011) is about 400 per year. Texas is considered by FHWA to be a “focus” state due to the high number of pedestrian crashes. This TxDOT project assisted the state with identifying characteristics of Texas pedestrian crashes and appropriate countermeasures to address those crashes. The following sections provide an overview and key findings from the various tasks completed in this project.

#### Literature Review

##### *Overview*

The literature review for this project focused on three main areas: pedestrian characteristics, safety evaluations, and treatments. Several recent research efforts that gathered information about pedestrian safety and potential crash reduction factors were included in the review. Also, recent evaluations of newer treatments (e.g., the pedestrian hybrid beacon and the rectangular rapid-flashing beacon) for pedestrian crossings were documented.

##### *Findings*

Key findings from the literature review were:

- **Pedestrian Characteristics** – Design of a pedestrian facility depends on a number of user characteristics: reasons for walking or not walking, settings (urban versus rural), pedestrian walking speed, pedestrian space requirements, and pedestrian age.
- **Safety Evaluations** – Factors influencing pedestrian crashes can be grouped into demographic/social/policy factors, driver factors, pedestrian factors, roadway/environmental factors, and vehicle factors. A recent FHWA publication provides estimates of the crash reduction that might be expected if specific countermeasures or a group of countermeasures is implemented with respect to pedestrian crashes.
- **Treatments** – A variety of engineering (e.g., geometric design, traffic control device), education (e.g., public awareness campaigns, curriculum-based education), and enforcement (e.g., high-visibility enforcement, fines for pedestrian right-of-way violation) treatments have the potential to improve safety at pedestrian crossings. However, it is key to consider site-specific environmental, traffic volume, traffic mix, geometric, and operational conditions for effective use of these treatments.

## **Funding Opportunities**

### *Overview*

Funding categories to address pedestrian safety span federal, state, and non-profit organizations and cover the three Es of engineering, education, and enforcement. The Surface Transportation Program–Metropolitan Mobility, Highway Safety Improvement Program, and Congestion Mitigation and Air Quality Improvement Program are examples of engineering-focused funding options. For education and enforcement, funding is available from Section 402 Highway Safety Funds, WalkWell Texas, and Safe Routes to School as well as others. MAP-21, passed in 2012, restructured core highway programs like the Surface Transportation Program, Highway Safety Improvement Program, and Congestion Mitigation and Air Quality Improvement Program. The legislation also eliminated most discretionary programs like the National Scenic Byways Program and the Public Lands Highway Discretionary Program.

The Federal Highway Administration provides funding to train agency staff on the development of pedestrian safety action plans for the focus states and cities.

Other states have funded pedestrian safety through initiatives like Washington’s Target Zero, which addresses the behavioral side of traffic safety, or North Carolina’s Bicycle and Pedestrian Planning Grant Initiative, which awards municipalities funding to develop comprehensive pedestrian plans. These states have set examples for funding pedestrian safety programs. Non-profit organizations such as AARP and Boltage, as well as the Robert Wood Johnson Foundation, have goals that relate to pedestrian safety, offering other alternatives for funding.

### *Findings*

Though there are several funding programs at the federal and state levels available for pedestrian safety projects, the challenge is the competition with projects focused on motor vehicles and public transportation. With the exception of the Safe Routes to School and Transportation Enhancement programs where livability projects that improve walking and bicycling receive priority, most categories invite projects for motor vehicle travel. Pedestrian and bicycle projects have difficulty competing for many of these funding categories. Projects like TIGER include pedestrian infrastructure as part of a larger project, but the larger projects are focused on road, transit, rail, and port projects. Other programs are similar in that they allow for pedestrian-focused projects, yet the primary goal is for another mode. For example, improving air quality or reducing energy consumption might be the primary goal, which could result in difficulty for pedestrian safety projects to compete. The “Systemic Safety Project Selection Tool” (27) may offer a solution.

## **Questionnaire on Pedestrian Safety Treatments**

### *Overview*

Researchers distributed a list of five questions to a selection of 10 city and TxDOT representatives in five metropolitan areas in Texas; four responses were received. Despite the

limited sample size, some findings can be made from the answers given by the respondents. Those findings are summarized below.

### *Findings*

**Issues.** Question 1 inquired about the current pedestrian safety-related issues that practitioners face. Key findings from Question 1 are summarized as follows:

- All respondents indicated that conflicts with right-turning vehicles were an issue for pedestrians.
- The City of Dallas noted potential issues at a variety of intersection types and with turning and through traffic. Other jurisdictions typically limited their responses to signalized intersections, unsignalized/no beacon intersections, and right-turning traffic.
- Every respondent noted an issue with uncontrolled midblock crossings without marked crosswalks, but midblock crossings in general—marked, controlled, or otherwise—were also perceived as a safety issue.
- Pedestrians walking along the roadside and school-related pedestrian traffic were non-intersection safety issues that were noted by multiple respondents.
- Dart/dash conflicts were identified by Dallas and Ft. Worth, and multiple-threat crossings were cited by Dallas.
- Nighttime crashes are a common problem, mentioned by three cities.
- San Antonio especially highlighted freeway crashes.
- Impaired pedestrians and drivers are important considerations, but other issues such as connectivity, transit waiting areas, and speeding vehicles were also mentioned.

**Treatments.** Respondents have used a variety of treatments, and they have considered others in their efforts to improve pedestrian safety. Questions 2 through 4 asked what treatments are being used, limitations on pedestrian treatments, and additional treatments considered but not used.

Key findings are summarized as follows:

- Engineering treatments are very common, particularly those with a signal or beacon component.
- Education strategies are also somewhat common, though they are not typically applied as part of a comprehensive program.
- Enforcement strategies are least common among the three categories discussed in these questions.
- The issue of limited resources (funding, personnel, or both) was easily the most common limitation on implementing additional treatments. This was also reflected in respondents' answers to treatments considered but not used (installation or maintenance costs).

**Additional Useful Information.** The practitioners responding to the final question in the list generally wanted to know more about the benefits of the treatments they were considering. In another nod to the issue of limited resources, responses to Question 5 centered on expected or known benefits—financial, safety, or otherwise—to treatments that could be used to improve pedestrian safety. Understandably, practitioners want to have a good appreciation for how a treatment will improve the problem they are attempting to address, and having that benefit information as part of a more comprehensive set of guidelines on best practices, design

standards, and compliance with ADA rules would be useful to the practitioners who responded to these questions.

## **Relationship between Roadway Characteristics and Driver Yielding to Pedestrians**

### *Overview*

Several traffic control devices are used at pedestrian crossings to improve conditions for crossing pedestrians including the traffic control signal, the pedestrian hybrid beacons, and the rectangular rapid-flashing beacons. The PHB and RRFB have shown great potential in improving driver yielding rates across the United States, and their positive effects at locations in Texas are worthy of further study. In addition, questions have been asked regarding under what roadway conditions—such as crossing distance (number of lanes) and posted speed limit—should each be considered. This research effort explored the factors associated with higher driver yielding at pedestrian crossings with TCS, RRFB, or PHB treatments in Texas. The objective of this study was to determine if selected roadway characteristics have an impact on the effectiveness of selected pedestrian crossing treatments as measured by the percent of drivers yielding to a staged pedestrian. Data were collected at 7 TCS sites, 22 RRFB sites, and 32 PHB sites.

### *Findings*

Key findings from the study include the following:

- The driver yielding rates vary by type of treatment. Overall, traffic control signals in Texas have the highest driver yielding rates with an average of 98 percent for the seven sites. The average driver yielding for RRFBs in Texas is 86 percent, while the average for PHBs is 89 percent.
- Comparing the Texas findings to national findings revealed similar results for traffic control signals. The RRFB results were slightly higher in Texas. A potential reason could be because all the RRFB sites included in this analysis had school crossing signs and were located near a school. For PHBs, the Texas findings were lower than the average driver yielding value of 97 percent for Tucson, Arizona. Additional education and enforcement should help to improve driver yielding within Texas.
- The number of devices within a city may have an impact on the driver yielding. Those cities with a greater number of a particular device (i.e., Austin for the PHB and Garland for the RRFB) had higher driver yielding rates as compared to cities where the device was only used at a few crossings.
- As drivers become more familiar with these devices over time, they may have a better understanding of expectations or requirements and driver yielding may improve. Comparing the number of days since installation for the Austin PHB sites revealed statistically significant higher driver yielding rates for those devices that had been installed longer. As drivers become more familiar with these devices, compliance may improve to be closer to what is seen in other states.
- For PHBs, wider crossing distances were associated with higher driver yielding results, although high average driver yielding results were observed for all crossing distances. These results support the use of the PHB on roadways with multiple lanes or a wide crossing.

- For PHBs, the posted speed limit was found to not be significant. Posted speed limits of 30, 35, 40, and 45 mph were included in the analysis.
- A few of the PHB sites did not have high driver yielding rates; however, reasons other than the posted speed limit or the crossing distances were attributed to the lower driver yielding values measured. The newness of the device, along with only being used in a few locations within the city, is suggested as being the cause for the low driver yielding observed.
- For RRFBs, statistically significant higher driver yielding rates are present for higher speed limits; however, the difference is not of practical significance. Only one percentage point difference is present between the average driver yielding for 35 mph sites (91 percent) and 40 mph sites (92 percent). The average for the two 45-mph sites was lower (84 percent).
- For RRFBs, lower compliance was observed for the longer crossing distances, which indicates that there is a crossing distance width where a device other than the RRFB should be considered. The data set included sites with total crossing distances that ranged between 38 and 120 ft.

## **Pedestrian and Motorist Behavior Before and After Installation of Pedestrian Treatments**

### *Overview*

This research effort identified the changes in motorist and pedestrian behaviors resulting from installing PHB or RRFB treatments at crosswalks in Texas. The objective of this study was to determine what effects these treatments had on driver yielding and selected pedestrian behaviors at previously untreated crosswalks.

### *Findings*

- Driver yielding rates for all pedestrian crossings at untreated sites were typically below 40 percent. For the treated sites, however, each showed a noticeable improvement in the number of yielding vehicles and the corresponding yielding rates after the treatments were installed, with total yielding rates increasing between 35 and 80 percentage points at each site.
- When considering only staged crossings and yielding rates for both directions (total), untreated sites had driver yielding rates below 30 percent, including some sites with zero yielding. Those rates increased noticeably after treatments were installed, as high as 89 percent for RRFB treatments and nearly 95 percent for the single PHB site.
- The number of non-staged pedestrian crossings after a treatment was installed did not change appreciably at most RRFB sites included in this study, but there was a fourfold increase in such crossings at the PHB site.
- Most (94 percent) of the non-staged pedestrians observed at the study sites activated the treatment when it was provided.
- Over half of non-staged pedestrians waited at the top of the curb ramp for an appropriate gap or a yielding vehicle, though over 20 percent waited at the edge of the travel lane similar to staged pedestrians. Nearside yielding rates were 100 percent for non-staged

pedestrians who waited at the edge of the travel lane, though nearside yielding was also high for those waiting at the top of the curb ramp.

- About 90 percent of non-staged pedestrians looked in at least one direction, and over half (70 of 112) checked both directions at least once prior to crossing.

## **In-Depth Review of Texas Pedestrian Crashes**

### *Overview*

This exploratory analysis of the 34,620 TxDOT-reportable pedestrian crashes in the CRIS data set (2007–2011) was conducted to obtain an understanding of Texas pedestrian crashes. Crash and person characteristics were analyzed. Additionally, geometric characteristics of 1554 TxDOT-reportable fatal and injury crashes that occurred in Austin, Bryan, Corpus Christi, Laredo, and San Antonio TxDOT Districts in 2011 were identified using aerial photographs.

### *Findings*

- For TxDOT-reportable traffic crashes 2 percent of all crashes and 15 percent of all fatal crashes were pedestrian related.
- TxDOT-reportable pedestrian fatal crashes as a proportion of all fatal crashes increased in 2011 when compared to 2010 (17 percent compared to 14 percent), whereas overall pedestrian crashes remained at 2 percent of all traffic crashes.
- Houston, Dallas, San Antonio, Austin, and Ft. Worth are the districts with the highest number of pedestrian crashes over the most recent 5-year period available (2007–2011).
- From 2007 to 2011, the Yoakum District had the most decrease and the Childress District had the most increase in all pedestrian crashes. Also, Wichita Falls District had the most decrease and the Lufkin District had the most increase in fatal pedestrian crashes in 2011 when compared to 2007.
- Most of the pedestrian crashes were found to be at non-rural locations with 85 percent of all pedestrian crashes and 70 percent of all fatal pedestrian crashes being at non-rural locations.
- Forty-seven percent of pedestrian crashes were found to be non-intersection related, and 53 percent were either at an intersection/driveway or related to the intersection.
- Eighty-nine percent of the pedestrian crashes were found to have occurred on the roadway, while 2 percent occurred on the shoulder and 0.2 percent on the median. Most pedestrian crashes were observed at locations with no traffic control device.
- Sixty-one percent of pedestrian crashes occurred during daylight, but for fatal pedestrian crashes only 23 percent occurred in daylight.
- Twenty-eight percent of the pedestrians involved and 27 percent of drivers involved were in the age group 41–64 years.
- As compared to a nearly even split between females and males in the general population, 61 percent of pedestrians and 50 percent of drivers (16 percent of drivers had unknown gender) involved in pedestrian-related crashes were male.
- Pedestrians and drivers mostly involved in pedestrian-related crashes were of either white or Hispanic ethnicities (ethnicity information is unknown for 62.5 percent of the pedestrians and 16 percent of the drivers).

- Ninety-five percent of fatal and injury pedestrian crashes (in Austin, Bryan, Corpus Christi, Laredo, and San Antonio TxDOT Districts) were on two-lane roads. The most common group of crash locations was two-lane roads with no left turn lanes and posted speed limits of 30 or 35 mph. Most of these crashes were outside school zones on roadways without on-street parking and with roadway lighting and sidewalks.

## **In-Depth Review of Texas Fatal Pedestrian Crashes**

### *Overview*

Overall, a total of 2232 TxDOT-reportable fatal pedestrian crashes were identified in the CRIS database (2007–2011), which is 15 percent of all TxDOT-reportable fatal crashes. Analysis of crash, person, roadway, and socioeconomic factors associated with these fatal crashes was conducted in this study. Additionally, geometric characteristics of 2203 TxDOT-reportable fatal pedestrian crashes were identified using aerial photographs.

### *Findings*

- The percent of TxDOT-reportable fatal crashes involving a pedestrian increased in 2011 when compared to 2010 and 2009 (17 percent compared to 14 percent).
- Eighty-nine percent of pedestrian fatalities had “multi-vehicle collision with the vehicle involved going straight” as the manner of collision.
- Seventy percent of fatal pedestrian crashes occurred in non-rural locations. This is slightly lower than the 2010 national observation of 73 percent.
- Eighty-seven percent of fatal pedestrian crashes occurred at non-intersection locations. This is higher than the 2010 national observation of 79 percent.
- Fifty-two percent of all fatal pedestrian crashes occurred on Interstate, U.S., or State highways.
- Review of the fatal pedestrian crash locations from aerial photographs showed the following:
  - The majority (64 percent) of crashes occurred at midblock locations with no traffic control. Among the 555 crashes that occurred at intersections, only 38 percent occurred at locations with marked crosswalks.
  - Almost all (93 percent) of the fatal pedestrian crashes were on roads without on-street parking.
  - Few (3 percent) of the crashes occurred in school zones, and only a quarter of the crashes occurred at locations with sidewalks and roadway lighting.
  - Thirty-nine percent of crashes occurred at locations with no median.
  - Most (68 percent) of the fatal pedestrian crashes occurred on roads with 4 or more lanes.
- More male pedestrians (72 percent) were killed in traffic crashes than females (28 percent).
- The pedestrian age group with the largest number of fatal pedestrian crashes is 41–64 years old. Drivers in the age groups 25–40 and 41–64 were equally represented in the fatal crash database.

- Alcohol test result information was available for only 18 percent of the Texas records. This is much lower than the 2010 national observation of 47 percent.
- Based on the available BAC test results, a higher proportion of pedestrians (19 percent) were tested to be over the legal limit (0.08 BAC) than drivers (13 percent). Nationally in 2010, 33 percent of pedestrians killed in traffic crashes were observed to be over 0.08 BAC.

## **Review of Fatal Pedestrian Crashes on High-Speed Roads in Texas**

### *Overview*

Over the most recent 5-year period available (2007–2011), 21 percent (474/2232) of all fatal TxDOT-reportable pedestrian crashes were found to have occurred on freeways. This is an alarmingly high number for an access-controlled facility where pedestrians are least expected. A review of the crash reports was conducted to obtain insight into the characteristics of these crashes.

### *Findings*

- For the fatal crashes on freeways, 42 percent occurred when the pedestrian attempted to cross the freeway for reasons not stated in the narrative text. Of the crashes on freeways, 26 percent of involved persons had exited their vehicle due to a stalled vehicle or a previous crash.
- Eighty-two percent of the freeway crashes occurred in dark conditions, 45 percent of which were at locations with no lighting.
- Pedestrians were under the influence of alcohol/drugs in 28 percent of the fatal crashes on freeways.
- In 71 percent of the freeway fatal pedestrian crashes, the pedestrian was believed to be at fault (by the officer).
- IH 45 in the Houston area has the highest frequency of fatal freeway pedestrian crashes, whereas IH 635 in the Dallas has the highest number of crashes per mile.

## **Analysis of Texas Pedestrian Crashes Using Classification Tree Models**

### *Overview*

In this study, the 34,620 TxDOT-reportable pedestrian crashes identified in the CRIS database (2007–2011) were studied using the classification tree methodology to identify significant factors influencing severity of crashes involving pedestrians in Texas.

### *Findings*

- Light condition, road class, traffic control, right shoulder width, involvement of a commercial vehicle, pedestrian age, and the manner in which the vehicles were moving prior to the first harmful event are critical in classifying the injury severity of pedestrian crashes.



- Pedestrian crashes are more likely in daylight conditions; however, the severity of the crash is more significant in dark conditions.
- More crashes occur on city streets, county roads, and other lower speed roads, whereas the severity of the crash is greater on higher speed roads, i.e. Interstates, U.S. and State highways, FM roads, and tollways.
- Younger ( $\leq 60$  years) pedestrians are involved in more crashes, whereas older ( $> 60$  years) pedestrians are more likely to be killed when struck by a vehicle.
- Commercial vehicle involvement in a pedestrian crash is associated with a greater probability of pedestrian fatality.
- Locations with no traffic control device or intersection-related traffic control devices (e.g., signal) are found to be associated with more pedestrian crashes; however, locations with segment traffic control devices (e.g., warning sign or flagger) are associated with a higher proportion of fatal pedestrian crashes.

## CONCLUSIONS

This TxDOT project identified characteristics of Texas pedestrian crashes. Two percent of all TxDOT-reportable traffic crashes and 15 percent of all TxDOT-reportable fatal crashes were pedestrian related. Pedestrian crashes are concentrated in urban areas with characteristics differing widely between non-fatal and fatal crashes. Examples include the following:

- Most pedestrian crashes occur in daylight; however, most fatal pedestrian crashes occur in dark conditions.
- Most pedestrian crashes occur at or near intersections and locations with no traffic control devices; however, most fatal pedestrian crashes occur away from intersections.
- Most pedestrian crashes occur on city streets; however, most fatal pedestrian crashes occur on high-speed roads.
- Most pedestrian crashes involve pedestrians younger than 60 years; however, most fatal pedestrian crashes involve pedestrians 60 years and older.

Several treatments are available, and the research team suggests consideration of the following infrastructure improvements, traffic control devices, and education or enforcement campaigns:

- Traffic control devices that attract pedestrians to cross at marked locations and that would generate the needed gap in traffic to permit a pedestrian to cross the road. Traffic control devices that are associated with high driver yielding include traffic control signals, pedestrian hybrid beacons, and rectangular rapid-flashing beacons. Note that these devices did not perform equally well in all locations; therefore, site characteristics should be considered when selecting a treatment.
- Features to improve pedestrian detectability, especially at night.
- Accommodations for older pedestrians when choosing a pedestrian safety installation.
- Educational and enforcement programs based on the following findings:
  - Pedestrians involved in 61 percent of all crashes and 72 percent of fatal crashes were male; 2010 U.S. Census shows equal proportion of male and female population in Texas.
  - Fifty percent of fatal pedestrian crashes occur over the weekend (Friday through Sunday) with more than half of them occurring between 8 p.m. and 4 a.m.

- Twenty-one percent of fatal pedestrian crashes occurred on access-controlled facilities. Most of these crashes involved a pedestrian attempting to cross the road.
- Pedestrians were under the influence of alcohol in 28 percent of the fatal crashes that occurred on access-controlled facilities.

For Texas, the average number of pedestrian fatalities during 2007–2011 is about 400 per year. Due to the high number of pedestrian crashes, Texas is considered by FHWA to be a “focus” state. Several agencies implementing systematic improvements have reported crash reduction results. Utilizing this approach to address pedestrian safety is less common. As a focus state, Texas is eligible for training and technical assistance from FHWA to implement the systematic approach for pedestrian safety. The following benefits could be realized by employing a systematic approach in Texas:

- Solves an unmet need in transportation safety.
- Uses a risk-based approach to prevent crashes.
- Results in a comprehensive road safety program.
- Advances a cost-effective means to address safety concerns (208).

Proactively addressing pedestrian crashes on a system-wide basis would reduce the risk of and the potential for the occurrence of future crashes.

Studies regarding the effectiveness of the pedestrian hybrid beacon and the rectangular rapid-flashing beacon provide the following additional conclusions:

- Use of the pedestrian hybrid beacon and rectangular rapid-flashing beacon provide improved driver yielding to pedestrians crossing at marked crosswalks and should be considered for other crosswalks where driver yielding is low.
- Despite the observed benefits, the installation of a traffic control device does not provide uniform results at all locations; the characteristics of a given crosswalk and the driver and pedestrian populations that travel through it should all be considered when determining whether to install one of these treatments.
- The RRFBs and PHBs did not have a significant or practical difference in driver yielding effectiveness for the range of speed limits studied (30 to 45 mph), suggesting that the devices are appropriate for that range of posted speed limits. It should be noted, however, that only a limited number of 45-mph installations were studied due to the rarity of treated sites at those higher speeds, especially for the RRFB. Additional research could verify the appropriateness of installing these devices on a 45-mph road.
- The field study included RRFB-treated sites with total crossing distances that ranged between 38 and 120 ft. Findings from the field study indicated that for RRFBs, lower compliance was observed for the longer crossing distances, which indicates that there is a crossing distance width where a device other than the RRFB should be considered.
- A jurisdiction that decides to install these devices should look for multiple places at which to install them, to provide more opportunities for pedestrians and drivers alike to become accustomed to their presence and their expected operation. Similarly, an education or outreach effort to nearby populations and expected users should be considered to improve user comprehension of the devices prior to their installation.

## FUTURE RESEARCH

Research that could assist Texas in reducing the number of pedestrian crashes includes the following:

- Development of guidelines on selecting appropriate pedestrian crossing treatments based on, at a minimum, posted speed limit and number of lanes. In addition, this study could investigate and determine the appropriate value for the minimum number of pedestrians that should be included in TxDOT guidelines for installing pedestrian treatments.
- Investigation into appropriate treatments for freeway pedestrian crashes.
- Development and implementation of a pilot study of the “Systemic Safety Project Selection Tool” focusing on pedestrian crashes in Texas. As a focus state, this tool offers a unique opportunity to address safety.
- Development of educational campaigns that could be used by cities and jurisdictions implementing RRFB and PHB devices.
- Development of other educational campaigns to address specific pedestrian behaviors or to educate pedestrians regarding their visibility to drivers. Examples of campaigns could include distracted walking, crossing freeways, walking during nighttime conditions, blind spots around commercial vehicles, and others.
- Evaluation of enforcement campaigns that target drivers not yielding to pedestrians and to target jaywalking pedestrians.
- Identify evaluation methods that can determine the effectiveness of the pedestrian safety campaigns, both education and enforcement.
- Follow-up study on motorist yielding in 3 to 5 years after other Texas cities have installed PHB and RRFB devices to determine whether Texas’ numbers have increased.
- Field evaluations of pedestrian safety with the flashing yellow arrow display.
- Field evaluations and comparisons of pedestrian crossing treatments that use LEDs. In addition to the RRFB, vendors are also promoting LED-embedded pedestrian crossing signs. Guidance on specifications for these devices—in terms of appropriate brightness and whether they should be dimmed at night—is needed. A secondary objective could be on how a set of roadway characteristics affects driver yielding behavior.
- Determination of reasonable values for estimates of induced pedestrian volume for various pedestrian treatments (i.e., estimated number of pedestrians that would now use the site because of the installation of a specific pedestrian treatment).
- Assessment of the influence of geometric design characteristics (e.g., number of lanes, presence of sidewalk, on-street parking) and traffic control type (e.g., presence of crosswalk) on pedestrian crashes (especially at midblock locations of city streets).
- Best practices for addressing pedestrian crashes on the following:
  - Controlled-access highways.
  - High-speed arterials.
  - Rail public transit (e.g., light rail, street cars), especially when quiet zones are implemented.
- Investigation into how best to automate needed pedestrian crash characteristics, as the Pedestrian and Bike Crash Analysis Tool is not a sustainable method.



## REFERENCES

- 1 Fitzpatrick, K., S. Turner, M. Brewer, P. Carlson, B. Ullman, N. Trout, E. S. Park, J. Whitacre, N. Lalani, and D. Lord (2006). *Improving Pedestrian Safety at Unsignalized Crossings*. TCRP Report 112/NCHRP Report 562. Transportation Research Board, Washington, D.C. [http://onlinepubs.trb.org/onlinepubs/nchrp/nchrp\\_rpt\\_562.pdf](http://onlinepubs.trb.org/onlinepubs/nchrp/nchrp_rpt_562.pdf)
- 2 Federal Highway Administration (2009). *Manual on Uniform Traffic Control Devices for Streets and Highways 2009 Edition*. U.S. Department of Transportation Federal Highway Administration, Washington, D.C.
- 3 Transportation Research Board (2010). *Highway Capacity Manual 2010*. Transportation Research Board, Washington, D.C.
- 4 Zegeer, C. and M. Bushell (2012). "Pedestrian Crash Trends and Potential Countermeasures From Around the World." *Accident Analysis & Prevention*, Vol. 44, Oxford, NY, Pergamon Press, pp. 3–11.
- 5 Zegeer, C., J. Stutts, H. Huang, M. Cynecki, R. Houten, B. Alberson, R. Pfefer, T. Neuman, K. Slack, and K. Hardy (2004). "Guidance for Implementation of the AASHTO Strategic Highway Safety Plan. Volume 10: A Guide for Reducing Collisions Involving Pedestrians." National Cooperative Highway Research Program, Research Report 500, Volume 10, Washington, D.C.
- 6 American Association of State Highway and Transportation Officials (AASHTO) (2010). *Highway Safety Manual 1st Edition*. American Association of State Highway and Transportation Officials, Washington, D.C.
- 7 Federal Highway Administration (n.d.). Crash Modification Factors Clearinghouse. <http://www.cmfclearinghouse.org/index.cfm>. Accessed January 13, 2012.
- 8 University of North Carolina Highway Safety Research Center (2013). "Toolbox of Countermeasures and Their Potential Effectiveness for Pedestrian Crashes." FHWA-SA-014. U.S. Department of Transportation, Federal Highway Administration. <http://www.walkinginfo.org/training/collateral/resources/pedToolboxofCountermeasures2013.pdf>. Accessed August 12, 2013.
- 9 Chen, L., C. Chen, R. Ewing, C. McKnight, R. Srinivasan, and M. Roe (2012). Safety Countermeasures and Crash Reduction in New York City—Experience and Lessons Learned. *Accident Analysis & Prevention*. Retrieved July 23, 2012. <http://www.sciencedirect.com/science/article/pii/S0001457512001613>.
- 10 Institute of Transportation Engineers (1985). *Determining Vehicle Change Intervals: A Proposed Recommended Practice*. ITE Technical Council Committee 4A-16.
- 11 Retting, R.A., J.F. Chapline, and A.F. Williams (2002). "Changes in Crash Risk Following Re-timing of Traffic Signal Change Intervals." *Accident Analysis & Prevention*, Vol. 34, No. 2, Oxford, NY, Pergamon Press, pp. 215–220.
- 12 Markowitz, F., S. Sciortino, J.L. Fleck, and B.M. Yee (2006). "Pedestrian Countdown Signals: Experience with an Extensive Pilot Installation." *ITE Journal*, January 2006, pp. 43–48. Updated by Memorandum, Olea, R. "Collision Changes 2002–2004 and Countdown Signals," (February 7, 2006).
- 13 Institute of Transportation Engineers (2004). "Toolbox of Countermeasures and their Potential Effectiveness to Make Intersections Safer." Briefing Sheet 8, ITE, FHWA.

- 14 Persuad, B., E. Hauer, R.A. Retting, R. Vallurupalli, and K. Mucsi (1997). "Crash Reductions Related to Traffic Signal Removal in Philadelphia." *Accident Analysis and Prevention*, Vol. 29, No. 6, Oxford, NY, Pergamon Press, pp. 803–810.
- 15 Harkey, D., S. Raghavan, J. Baek, F.M. Council, K. Eccles, N. Lefler, F. Gross, B. Persaud, C. Lyon, E. Hauer, and J. A. Bonneson. (2008). "Crash Reduction Factors for Traffic Engineering and ITS Improvements." NCHRP Report No. 617, Transportation Research Board, Washington, D.C.
- 16 Fitzpatrick, K., and E.S. Park (2010). *Safety Effectiveness of the HAWK Pedestrian Crossing Treatment*. Report No. FHWA-HRT-10-042, Federal Highway Administration, Washington, D.C.
- 17 Currie, G., and P. Smith (2005). "An Innovative Design for Safe and Accessible Light Rail/Tram Stops Suitable for Streetcar Style Conditions." 06-0279, Committee Number AP075, TRB Committee on Light Rail Transit, TRB 2006 Annual Meeting CD-ROM, pp. 1–15.
- 18 De Brabander, B., and L. Vereeck (2006). "Safety Effects of Roundabouts in Flanders: Signal type, speed limits and vulnerable road users." AAP-1407, Elsevier Science.
- 19 Gan, A., J. Shen and A. Rodriguez (2005). "Update of Florida Crash Reduction Factors and Countermeasures to Improve the Development of District Safety Improvement Projects." Florida Department of Transportation.
- 20 Zegeer, C., R. Stewart, H. Huang and P. Lagerwey (2002). *Safety Effects of Marked vs. Unmarked Crosswalks at Uncontrolled Locations: Executive Summary and Recommended Guidelines*, Report No. FHWA-RD-01-075, Federal Highway Administration, Washington, D.C., FHWA-RD-01-075.
- 21 Bahar, G., M. Parkhill, E. Hauer, F. Council, B. Persaud, C. Zegeer, R. Elvik, A. Smiley, and B. Scott (2007). "Prepare Parts I and II of a Highway Safety Manual: Knowledge Base for Part II." Unpublished material from NCHRP Project 17–27, May 2007.
- 22 McMahon, P., C. Zegeer, C. Duncan, R. Knoblauch, R. Stewart, and A. Khattak (2002). "An Analysis of Factors Contributing to 'Walking Along Roadway' Crashes: Research Study and Guidelines for Sidewalks and Walkways." FHWA-RD-01-101, March 2002.
- 23 Van Houten, R., and J. Louis Malenfant (2004). "Effects of a Driver Enforcement Program on Yielding to Pedestrians." *Journal of Applied Behavior Analysis*, 37, 351–363.
- 24 Feldman, M., J.G. Manzi and M. Mitman (2010). An Empirical Bayesian Evaluation of the Safety Effects of High-Visibility School (Yellow) Crosswalks in San Francisco. In *Transportation Research Record 2198*, Transportation Research Board, National Research Council, Washington, D.C., pp. 8–14.
- 25 Wemple, B. (2013). "Ask the Experts—Implementing the Systemic Approach to Safety: What is the systemic approach to safety?" Webpage, Cambridge Systematics.  
[http://www.camsys.com/kb\\_experts\\_systemic.htm](http://www.camsys.com/kb_experts_systemic.htm).
- 26 Federal Highway Administration (2013). *A Systematic Approach to Safety*. Publication FHWA-SA-12-025., U.S. Department of Transportation.  
<http://safety.fhwa.dot.gov/systemic/pdf/SystemicOverviewFlyer.pdf>. Accessed July 22, 2013.

- 27 Pedestrian and Bicycle Information Center (2013). *Systemic Safety Project Selection Tool*. [http://www.walkinginfo.org/training/pbic/pedfocus\\_webinar\\_05-28-2013.cfm](http://www.walkinginfo.org/training/pbic/pedfocus_webinar_05-28-2013.cfm). Accessed July 22, 2013.
- 28 Center for Urban Transportation Research (CUTR) (2000). *Making Crosswalks Safer for Pedestrians: Application of a Multidisciplinary Approach to Improve Pedestrian Safety at Crosswalks in St. Petersburg, Florida*, University of South Florida, Tampa, Florida, July.
- 29 Van Houten, R. (1988). "The Effects of Advance Stop Lines and Sign Prompts on Pedestrian Safety in a Crosswalk on a Multilane Highway," In *Journal of Applied Behavioral Analysis*, Vol. 21, pp. 245–251.
- 30 Van Houten, R., and L. Malenfant (1992). "The Influence of Signs Prompting Motorists to Yield before Marked Crosswalks on Motor Vehicle–Pedestrian Conflicts at Crosswalks with Flashing Amber." *Accident Analysis & Prevention*, Vol. 24, No. 3, pp. 217–225.
- 31 Van Houten, R., J.E.L. Malenfant, and D. McCusker (2001). "Advance Yield Markings: Reducing Motor Vehicle–Pedestrian Conflicts at Multilane Crosswalks with Uncontrolled Approach." In *Transportation Research Record 1773*, Transportation Research Board, National Research Council, Washington, D.C., pp. 69–74.
- 32 Van Houten, R., D. McCusker, S. Huybers, J.E.L. Malenfant, and D. Rice-Smith (2002). "Advance Yield Markings and Fluorescent Yellow-Green RA 4 Signs at Crosswalks with Uncontrolled Approaches." In *Transportation Research Record 1818*, Transportation Research Board, National Research Council, Washington, D.C., pp. 119–124.
- 33 Pulugurtha, S., S.S. Nambisan, M.R. Dangeti, and V. Vasudevan (2011). "An Evaluation of Effectiveness of Traffic Signs to Enhance Pedestrian Safety." 89<sup>th</sup> Annual Transportation Research Board Meeting Compendium of Paper CD.
- 34 Van Winkle, J.W., and D.A. Neal (2000). "Pedestrian-Actuated Crosswalk Flashers." Paper presented at the ITE 2000 Annual Meeting, Institute of Transportation Engineers.
- 35 Fisher, J.E. (n.d.). *The Smart and Smarter Pedestrian Warning*. City of Los Angeles Department of Transportation, Los Angeles, California.
- 36 Huang, H. (2000). An Evaluation of Flashing Crosswalks in Gainesville and Lakeland. For Florida Department of Transportation. [http://www.dot.state.fl.us/Safety/ped\\_bike/handbooks\\_and\\_research/research/FLASHXW%20in%20gville%20lakeland.pdf](http://www.dot.state.fl.us/Safety/ped_bike/handbooks_and_research/research/FLASHXW%20in%20gville%20lakeland.pdf). Accessed April 20, 2011.
- 37 Little, T., and J. Saak (2010). "The Ustick Road Corridor—A Case Study in Pedestrian Crossings." Paper presented at the ITE Annual Meeting, Institute of Transportation Engineers.
- 38 Sparks, J.W., and M.J. Cynecki (1990). "Pedestrian Warning Flashers in an Urban Environment: Do They Help?" In *ITE Journal*, Vol. 60, No. 1, Institute of Transportation Engineers, pp. 32–36.
- 39 Fitzpatrick, K., S.T. Chrysler, V. Iragavarapu, and E.S. Park (2010). *Crosswalk Marking Field Visibility Study*. Report No. FHWA-HRT-10-067, Federal Highway Administration, Washington, D.C.
- 40 Tobin, J.R. (1999). "Standards & Guidelines for Midblock Crossings: Las Vegas Study." Paper presented at the ITE 1999 Annual Meeting, Institute of Transportation Engineers.
- 41 Whitlock and Weinberger Transportation, Inc. (1998). *An Evaluation of a Crosswalk Warning System Utilizing In-Pavement Flashing Lights*. Santa Rosa, California.

- 42 Evans, D. (1999). "The Light of Your Life: In-Pavement LEDs Stop Cars and Save Lives." Traffic Technology International, 1999 Annual Review, Vol. 5, No. 6, Surrey, United Kingdom.
- 43 Godfrey, D., and T. Mazzella (1999). "Kirkland's Experience with In-Pavement Flashing Lights at Crosswalks." Presented at the ITE/IMSA Annual Meeting, Lynnwood, Washington.
- 44 Katz, Okitsu, and Associates (2000). *City of Fountain Valley Illuminated Crosswalks: An Evaluation Study and Policy Recommendations*.  
[http://www.xwalk.com/images/advocacy/ftnvllly\\_study.pdf](http://www.xwalk.com/images/advocacy/ftnvllly_study.pdf). Accessed April 20, 2011.
- 45 Prevedouros, P.D. (2001). "Evaluation of In-Pavement Flashing Lights on a Six-Lane Arterial Pedestrian Crossing." Paper presented at the ITE 2001 Annual Meeting, Institute of Transportation Engineers.
- 46 Huang, H., R. Hughes, C. Zegeer, and M. Nitzburg (1999). "An Evaluation of the LightGuard™ Pedestrian Crosswalk Warning System." Highway Safety Research Center, University of North Carolina, Chapel Hill, North Carolina.
- 47 Thomas, L. (n.d.). "What is the Effect of In-Pavement Flashing Lights on Motorist Speeds, Yielding Behavior, and Conflicts with Pedestrians?" walkinginfo.org.  
<http://www.walkinginfo.org/faqs/answer.cfm?id=3903>. Accessed April 20, 2011.
- 48 Van Derlofske, J.F., P.R. Boyce, and C.H. Gilson (2003). Evaluation of In-Pavement, Flashing Warning Lights on Pedestrian Crosswalk Safety. TRB 2003 Annual Meeting: Washington, D.C.
- 49 Hakkert, A.S., V. Gitelman, and E. Ben-Shabat (2002). An Evaluation of Crosswalk Warning Systems: Effects on Pedestrian and Vehicle Behavior. Transportation Research Part F (5): 275–292.
- 50 Karkee, G.J., S.S. Nambisan, and S.S. Pulugurtha (2006). An Evaluation of the Effectiveness of an In-Pavement Flashing Light System. 85<sup>th</sup> Transportation Research Board Annual Meeting: Washington, D.C.
- 51 Kannel, E.J., and W. Jansen (2004). In-Pavement Pedestrian Flasher Evaluation: Cedar Rapids, Iowa. Iowa Department of Transportation: Ames, Iowa.  
[http://www.ctre.iastate.edu/reports/ped\\_flasher.pdf](http://www.ctre.iastate.edu/reports/ped_flasher.pdf). Accessed April 20, 2011.
- 52 Malek, M. (2001). Crosswalk Enhancement Comparison Study. Prepared by the City of San Jose Department of Transportation.
- 53 Boyce, P., and J.V. Derlofske (2002). Pedestrian Crosswalk Safety: Evaluating In-Pavement, Flashing Warning Lights: Final Report. In cooperation with New Jersey Department of Transportation, U.S. Department of Transportation, Federal Highway Administration.
- 54 Pécheux, K., J. Bauer, P. McLeod (2009). *Pedestrian Safety and ITS-Based Countermeasures Program for Reducing Pedestrian Fatalities, Injury Conflicts, and Other Surrogate Measures Draft Zone/Area-Wide Evaluation Technical Memorandum*. Contract # DTFH61-96-C-00098; Task 9842. U.S. Department of Transportation, ITS Joint Program Office, Washington, D.C. [http://safety.fhwa.dot.gov/ped\\_bike/tools\\_solve/ped\\_scdproj/sys\\_impact\\_rpt/index.cfm#toc](http://safety.fhwa.dot.gov/ped_bike/tools_solve/ped_scdproj/sys_impact_rpt/index.cfm#toc). Accessed April 20, 2011.



- 55 Ellis, Jr., R.D., R. Van Houten, and J. Kim (2007). "In Roadway 'Yield to Pedestrians' Signs: Placement Distance and Driver Yielding." In *Transportation Research Record 2002*, Transportation Research Board, National Research Council, Washington, D.C., pp. 84–89.
- 56 Strong, C., and M. Kumar (2006). "Safety Evaluation of Yield-to-Pedestrian Channelizing Devices." Western Transportation Institute, Montana State University.
- 57 Strong, C., and D. Bachman (2008). "Safety Evaluation of Yield-to-Pedestrian Channelizing Devices." In TRB 87<sup>th</sup> Annual Meeting Compendium of papers DVD.
- 58 Huang, H., C. Zegeer, and R. Nassi (2000). "Effects of Innovative Pedestrian Signs at Unsignalized Locations: Three Treatments." In *Transportation Research Record 1705*, Transportation Research Board, National Research Council, Washington, D.C., pp. 43–52.
- 59 Kannel, E.J., R.R. Souleyrette, and R. Tenges (2003). *In-Street Yield to Pedestrian Sign Application in Cedar Rapids, Iowa*, Center for Transportation Research and Education, Iowa State University, Ames, IA.
- 60 Kamyab, A., S. Andriele, and D. Kroeger (2002). *Methods to Reduce Traffic Speed in High Pedestrian Areas*, Report 2002-18, Prepared for the Minnesota Department of Transportation, St. Paul, MN.
- 61 City of Madison Traffic Engineering Division (1999). "Year 2 Field Evaluation of Experimental 'In-Street' Yield to Pedestrian Signs," City of Madison Department of Transportation, Madison, WI.
- 62 Fayish, A., and F. Gross (2010). "Safety Effectiveness of Leading Pedestrian Intervals Evaluated by a Before-After Study with Comparison Groups." In *Transportation Research Record 2198*, Transportation Research Board, National Research Council, Washington, D.C.
- 63 Zegeer, C.V., J.R. Stewart, H. Huang, and P. Lagerway (2001). "Safety Effects of Marked versus Unmarked Crosswalks at Uncontrolled Locations: Analysis of Pedestrian Crashes in 30 Cities." In *Transportation Research Record 1773*, Transportation Research Board, National Research Council, Washington, D.C., pp. 56–68.
- 64 Koepsell, T., L. McCloskey, M. Wolf, A.V. Moudon, D. Buchner, J. Kraus, and M. Patterson (2002). "Crosswalk Markings and the Risk of Pedestrian-Motor Vehicle Collisions in Older Pedestrians." *Journal of the American Medical Association*, Vol. 288, No. 17.
- 65 Knoblauch, R.L., M. Nitzburg, and R.F. Seifert (2001). *Pedestrian Crosswalk Case Studies: Sacramento, California; Richmond, Virginia; Buffalo, New York; Stillwater, Minnesota*. Report No. FHWA-RD-00-103, Federal Highway Administration, Washington, D.C.
- 66 Gibby, A.R., J. Stites, G.S. Thurgood, and T.C. Ferrara (1994). *Evaluation of Marked and Unmarked Crosswalks at Intersections in California: Final Report*. Report No. FHWA/CA/TO-94/1, California Department of Transportation, Sacramento, California.
- 67 Herms, B.F. (1970). *Pedestrian Crosswalk Study: Accidents in Painted and Unpainted Crosswalks*. San Diego, California.
- 68 Herms, B.F. (1972). "Pedestrian Crosswalk Study: Accidents in Painted and Unpainted Crosswalks." In *Highway Research Record 406*, Highway Research Board, National Research Council, Washington, D.C., pp. 1–14.

- 69 Huang, H., and C. Zegeer (2000). "The Effects of Pedestrian Countdown Signals in Lake Buena Vista." University of North Carolina at Chapel Hill Highway Safety Research Center, Chapel Hill, North Carolina.
- 70 Maxwell, A., J. Kennedy, I. Routledge, P. Knight, K. Wood (2011). Puffin Pedestrian Crossing Accident Study. PPR507, Transport Research Laboratory.
- 71 Fischer, E.L., G.K. Rousseau, S.M. Turner, E.J. Blais, C.L. Engelhart, D.R. Henderson, J.A. Kaplan, V.M. Keller, J.D. Mackay, P.A. Tobias, D.E. Wigle, and C.V. Zegeer (2010). *Pedestrian and Bicyclist Safety and Mobility in Europe*. Office of International Programs, Federal Highway Administration, Washington, D.C.
- 72 Shurbutt, J., and R. Van Houten (2010). *Effects of Yellow Rectangular Rapid-Flashing Beacons on Yielding at Multilane Uncontrolled Crosswalks*. Report No. FHWA-HRT-10-043, Federal Highway Administration, Washington, D.C.
- 73 Brewer, M.A., K. Fitzpatrick, G.W. Larson, and H. Minter (2011). *Before-and-After Study of the Effectiveness of Rectangular Rapid-Flashing Beacons used with School Sign in Garland, Texas*. Technical Memorandum to City of Garland Department of Transportation. Texas Transportation Institute, College Station, Texas.
- 74 Furst, A. (2008). "MUTCD- Interim Approval for Optional Use of Rectangular Rapid Flashing Beacons (IA-11)." U.S. Department of Transportation Federal Highway Administration Memorandum, July 16, Washington, D.C.
- 75 Pécheux, K., J. Bauer, and P. McLeod (2009). *Pedestrian Safety Engineering and ITS-Based Countermeasures Program for Reducing Pedestrian Fatalities, Injury Conflicts, and Other Surrogate Measures Final System Impact Report*. Federal Highway Administration, U.S. Department of Transportation.
- 76 Hunter, W.W., R. Srinivasan, and C. A. Martell. (2009). *Evaluation of the Rectangular Rapid Flash Beacon at a Pinellas Trail Crossing in St. Petersburg, Florida*. Florida Department of Transportation, Tallahassee, Florida.
- 77 Ross, J., D. Serpico, and R. Lewis (2011). *Assessment of Driver Yielding Rates Pre- and Post-RRFB Installation, Bend, Oregon*. Oregon Department of Transportation, Salem, Oregon.
- 78 Madaniyo, M. (2010). "Sight Obstruction at At-Grade Pedestrian Crossings: A Review of the Understanding of the Meaning of Zigzag Lines." *Safety Science* Vol. 48, pp. 283–287.
- 79 Campbell, B.J., C.V. Zegeer, H.H. Huang, and M.J. Cynecki (2003). *A Review of Pedestrian Safety Research in the United States and Abroad*. Report No. FHWA-RD-03-042. Federal Highway Administration.
- 80 Berger, W.G. (1975). *Urban Pedestrian Accident Countermeasures Experimental Evaluation Studies. Vol. I – Behavioral Evaluation Studies. Vol. II – Accident Studies. Vol. III – Appendix A*. Report Nos. DOT-HS-801-346, 347, and 348, National Highway Traffic Safety Administration.
- 81 Knoblauch, R.L. (1977). *Causative Factors and Countermeasures for Rural and Suburban Pedestrian Accidents: Accident Data Collection and Analysis*, Report No. DOT-HS-802-266, National Highway Traffic Safety Administration.
- 82 Snyder, M.B. and R.L. Knoblauch (1971). *Pedestrian Safety: The Identification of Precipitating Factors and Possible Countermeasures*, Report No. DOT-HS-800-403, 2 Vols., National Highway Traffic Safety Administration.

- 83 Knoblauch, R.L., W. Moore, Jr., and P.R. Schmitz (1978). *Pedestrian Accidents Occurring on Freeways: An Investigation of Causative Factors. Accident Data Collection and Analysis*, Report Nos. FHWA-RD-78-169/171, Federal Highway Administration.
- 84 Federal Highway Administration (1987). *Model Pedestrian Safety Program. User's Manual*. Report No. FHWA-IP-78-6, Federal Highway Administration, 1977 and 1987 editions.
- 85 Jacobs, G.D. (1966). "Pedestrian Behavior on a Length of Road Containing Guard Rails." *Traffic Engineering and Control*, January 1966.
- 86 Japan Road Association (1969). *Accident Prevention Effects of Road Safety Devices—Annual Report*. Japan Road Association.
- 87 Pécheux, K.K., J. Bauer, S. Miller, J. Rephlo, H. Saporta, S. Erickson, S. Knapp, and J. Quan (2008). *Guidebook for Mitigating Fixed-Route Bus-and-Pedestrian Collisions*. TCRP Report 125.
- 88 Sandels, S. (1979). *The Skandia Report III, Unprotected Road Users, A Behavioral Study*. Skandia Insurance Co.
- 89 Fitzpatrick, K., K. Hall, D. Perkinson, L. Nowlin, and R. Koppa (1996). *Guidelines for the Location and Design of Bus Stops*. TCRP Report 19.
- 90 Hawley, L., C. Henson, A. Hulse, and R. Brindle (1992). *Towards Traffic Calming: A Practitioners' Manual of Implemented Local Area Traffic Management and Blackspot Devices*. Publication No. CR 126, Federal Office of Road Safety, Canberra, Australian Capital Territory, Australia.
- 91 Replogle, M. (1992). *Bicycle and Pedestrian Policies and Programs in Asia, Australia, and New Zealand. Case Study 17, National Bicycling and Walking Study*. Report No. FHWA-PD-93-016. Federal Highway Administration, Washington, D.C.
- 92 Macbeth, A. (1995). "Balliol Street, City of Toronto." *Traffic Engineering Committee Workshop, Proceedings from 21 Papers, Ontario Traffic Conference*, Toronto, Ontario.
- 93 Huang, H.F., and M.J. Cynecki (2001). *The Effects of Traffic Calming Measures on Pedestrian and Motorist Behavior*. Report No. FHWA-RD-00-104. Federal Highway Administration, Washington, D.C.
- 94 Pegrum, B.V. (1972). "The Application of Certain Traffic Management Techniques and Their Effect on Road Safety." National Road Safety Symposium.
- 95 Polus, A., and A. Katz (1978). "An Analysis of Nighttime Pedestrian Accidents at Specially Illuminated Crosswalks." *Accident Analysis & Prevention*, Vol. 10, No. 3.
- 96 Freedman, M., M.S. Janoff, B.W. Koth, and W. McCunney (1975). *Fixed Illumination for Pedestrian Protection*, Report No. FHWA-RD-76-8, Federal Highway Administration, Washington, D.C.
- 97 Nambisan, S.S., S.S. Pulugurtha, V. Vasudevan, M.R. Dangeti, and V. Virupaksha (2009). "Effectiveness of Automatic Pedestrian Detection Device and Smart Lighting for Pedestrian Safety." In *Transportation Research Record 2140*, Transportation Research Board, National Research Council, Washington, D.C.
- 98 Nabors, D., R. Schneider, D. Leven, K. Lieberman, and C. Mitchell. *Pedestrian Safety Guide for Transit Agencies* (2008). Report No. FHWA-SA-07-017. Federal Highway Administration, Washington, D.C.

- 99 Moore, R.L., and S.J. Older (1965). "Pedestrians and Motor Vehicles are Compatible in Today's World." *Traffic Engineering*, Vol. 35, No. 12.
- 100 Swan, S. (1978). "Treatments of Overpasses and Undercrossing for the Disabled: Early Report on the State-of-the Art." In *Transportation Research Record 683*, Transportation Research Board, National Research Council, Washington, D.C.
- 101 Templer, J. (1980). *Development of Priority Accessible Networks – An Implementation Manual – Provisions for the Elderly and Handicapped Pedestrians*. Report No. FHWA/IP80/8, Federal Highway Administration, Washington, D.C.
- 102 Federal Highway Administration (2010). *Safety Benefits of Raised Medians and Pedestrian Refuge Areas*. Report No. FHWA-SA-10-031. Federal Highway Administration, Washington, D.C.
- 103 Bowman, B.L., and R.L. Vecellio (1994). "Effects of Urban and Suburban Median Types on both Vehicular and Pedestrian Safety." In *Transportation Research Record 1445*, Transportation Research Board, National Research Council, Washington, D.C.
- 104 Bowman, B.L., and R.L. Vecellio (1994). "Assessment of Current Practice in Selection and Design of Urban Medians to Benefit Pedestrians." In *Transportation Research Record 1445*, Transportation Research Board, National Research Council, Washington, D.C.
- 105 Bacquie, R., D. Egan, and L. Ing (2001). "Pedestrian Refuge Island Safety Audit," Paper presented at the ITE 2001 Technical Conference and Exhibit, Institute of Transportation Engineers, Washington, D.C., March 2001.
- 106 Federal Highway Administration (2010). *HSIS Summary Report: Evaluation of Lane Reduction "Road Diet" Measures on Crashes*. Report No. FHWA-HRT-10-053. Federal Highway Administration, Washington, D.C.
- 107 Tobey, H.N., E.M. Shunamen, and R.L. Knoblauch (1983). *Pedestrian Trip Making Characteristics and Exposure Measures*, DTFH61-81-C-00020, Federal Highway Administration.
- 108 Federal Highway Administration (2010). *Safety Benefits of Walkways, Sidewalks, and Paved Shoulders*. Report No. FHWA-SA-10-022. Federal Highway Administration, Washington, D.C.
- 109 Knoblauch, R., B. Tustin, S. Smith, and M. Pietrucha (1987). *Investigation of Exposure-Based Pedestrian Accident Areas: Crosswalks, Sidewalks, Local Streets, and Major Arterials*. Publication No. FHWA-RD-87-038, FHWA, Washington, D.C.
- 110 Ellis, R., and R. Van Houten (2009). Reduction of Pedestrian Fatalities, Injuries, Conflicts, and Other Surrogate Measures in Miami-Dade, Florida. In *Transportation Research Record 2140*, Transportation Research Board, National Research Council, Washington, D.C., pp. 55–62.
- 111 Chicago Department of Transportation (2005). "Evaluation of School Traffic Safety Program Traffic Control Measure Effectiveness."  
<http://mutcd.fhwa.dot.gov/resources/policy/ygcrosswalkmarking/chicagostudy/index.htm>. Accessed April 17, 2011.
- 112 Pedestrian and Bicycle Information Center. <http://www.walkinginfo.org>. Accessed October 30, 2011.
- 113 National Center for Safe Routes to School. <http://www.saferoutesinfo.org>. Accessed October 30, 2011.

- 114 Pedestrian and Bicycle Information Center (2010). *Pedestrian and Bicycle Information Center Case Study Compendium*. University of North Carolina Highway Safety Research Center, Chapel Hill, North Carolina.
- 115 Perils for Pedestrians. <http://www.pedestrians.org/>. Accessed October 30, 2011.
- 116 Babka, J., J. Cooper, W. Alfsen, and M. Sabin (2010). "Community Pedestrian Safety Engagement Workshops in California." *2011 TRB Compendium of Papers*, Transportation Research Board, Washington, D.C.
- 117 Lobb, B., N. Harré, and N. Terry (2003). "An Evaluation of Four Types of Railway Pedestrian Crossing Safety Intervention." *Accident Analysis & Prevention*, Vol. 35, No. 4, pp. 487–494.
- 118 Duperrex, O., F. Bunn, and I. Roberts (2002). "Safety Education of Pedestrians for Injury Prevention: a Systematic Review of Randomized Controlled Trials." *BMJ*, Vol. 324, No. 1129.
- 119 Livingston, D.H., I. Suber, D. Snyder, S.F. Clancy, M.R. Passannante, and R.F. Lavery (2011). "Annual Pediatric Pedestrian Education Does Not Improve Pedestrian Behavior." *The Journal of Trauma*, Vol. 71, No. 5, pp. 1120–1124.
- 120 Glang, A., J. Noell, D. Ary, and L. Swartz (2005). "Using Interactive Multimedia to Teach Pedestrian Safety: an Exploratory Study." *American Journal of Health Behavior*, Vol. 29, No. 5, pp. 435–442.
- 121 Zeedyk, M.S. and L. Wallace (2003). "Tackling Children's Road Safety through Edutainment: an Evaluation of Effectiveness." *Health Education Research*, Vol. 18, No. 4, pp. 493–505.
- 122 Barton, B.K., D.C. Schwebel, and B.A. Morrongiello (2007). "Brief Report: Increasing Children's Safe Pedestrian Behaviors through Simple Skills Training." *Journal of Pediatric Psychology*, Vol. 32, No. 4, pp. 475–480.
- 123 Berry, D.S., and C.V. Romo (2006). "Should 'Cyrus the Centipede' Take a Hike? Effects of Exposure to a Pedestrian Safety Program on Children's Safety Knowledge and Self-Reported Behaviors." *Journal of Safety Research*, Vol. 37, No. 4, pp. 333–341.
- 124 McComas, J., M. MacKay, and J. Pivik (2002). "Effectiveness of Virtual Reality for Teaching Pedestrian Safety." *Cyberpsychology & Behavior: The Impact of the Internet, Multimedia and Virtual Reality on Behavior and Society*, Vol. 5, No. 3, pp. 185–190.
- 125 Schwebel, D.C., J. Gaines, and J. Severson (2008). "Validation of Virtual Reality as a Tool to Understand and Prevent Child Pedestrian Injury." *Accident Analysis & Prevention*, Vol. 40, No. 4, pp. 1394–1400.
- 126 Schwebel, D.C., and L.A. McClure (2010). "Using Virtual Reality to Train Children in Safe Street-Crossing Skills." *Injury Prevention: Journal of the International Society for Child and Adolescent Injury Prevention*, Vol. 16, No. 1, pp. e1–5.
- 127 Hotz, G., S. Cohn, A. Castelblanco, S. Colston, M. Thomas, A. Weiss, J. Nelson, and R. Duncan (2004). "WalkSafe: A School-Based Pedestrian Safety Intervention Program." *Traffic Injury Prevention*, Vol. 5, No. 4, pp. 382–389.
- 128 Hotz, G., A.G. de Marcilla, K. Lutfi, A. Kennedy, P. Castellon, and R. Duncan (2009). "The WalkSafe Program: Developing and Evaluating the Educational Component." *The Journal of Trauma*, Vol. 66, No. 3, pp. S3–9.

- 129 Roberts, I., T. Ashton, R. Dunn, and T. Lee-Joe (1994). "Preventing Child Pedestrian Injury: Pedestrian Education or Traffic Calming?" *Australian Journal of Public Health*, Vol. 18, No. 2, pp. 209–212.
- 130 Mitman, M., and D. Ragland (2007). "Crosswalk Confusion, More Evidence Why Pedestrian and Driver Knowledge of the Vehicle Code Should Not Be Assumed." In *Transportation Research Record 2002*, Transportation Research Board, National Research Council, Washington, D.C., pp. 55–63.
- 131 Savolainen, P., T. Gates, and T. Datta (2010). "Implementation of Targeted Pedestrian Enforcement Programs in an Urban Environment." *2011 TRB Compendium of Papers*, Transportation Research Board, Washington, D.C.
- 132 United States Government Accountability Office (2008). *Improved Reporting and Performance Measures Would Enhance Evaluation of High-Visibility Campaigns*. United States Government Accountability Office, Report Number GAO-08-477, Washington, D.C.
- 133 Federal Highway Administration (2008). Pedestrian Safety Report to Congress. [http://safety.fhwa.dot.gov/ped\\_bike/legis\\_guide/rpts\\_cnrgs/pedrpt\\_0808/chap\\_4.cfm](http://safety.fhwa.dot.gov/ped_bike/legis_guide/rpts_cnrgs/pedrpt_0808/chap_4.cfm). Accessed November 22, 2011.
- 134 Zegeer, C., and M. Bushell (2010). *Pedestrian Crash Trends and Potential Countermeasures from Around the World*. University of North Carolina Highway Safety Research Center. Chapel Hill, North Carolina.
- 135 "Moving Ahead for Progress in the 21<sup>st</sup> Century Act (MAP-21) webpage. July 17, 2012. Federal Highway Administration website. U.S. Department of Transportation, Washington, D.C. <http://www.fhwa.dot.gov/map21/summaryinfo.cfm>. Accessed August 6, 2013.
- 136 "Safe Accountable Flexible Efficient Transportation Equity Act: A Legacy for Users" webpage. Federal Highway Administration website. U.S. Department of Transportation. Washington, D.C. <https://www.fhwa.dot.gov/safetealu/legis.htm>. Accessed August 27, 2013.
- 137 "Background" webpage. (n.d.). *Surface Transportation Environment and Planning Cooperative Research Program (STEP)* website. Office of Planning, Environment, & Realty, Federal Highway Administration. Washington, D.C. [http://www.fhwa.dot.gov/hep/step/about\\_step/background/](http://www.fhwa.dot.gov/hep/step/about_step/background/). Accessed July 11, 2013.
- 138 *National Transportation Alternatives Clearinghouse (NTAC)* website. (n.d.). Surface Transportation Environment and Planning Cooperative Research Program (STEP). Washington, D.C. <http://www.ta-clearinghouse.info/index>. Accessed July 11, 2013.
- 139 "2012 Discretionary Grant Programs" webpage. (n.d.). Federal Highway Administration website. U.S. Department of Transportation. Washington, D.C. <http://www.fhwa.dot.gov/discretionary/tcsp2012selc.htm>. Accessed July 11, 2013.
- 140 "Public Lands Highway Discretionary (PLHD)" webpage. (n.d.). *Federal Lands Highway*. Office of Federal Lands Highway, Federal Highway Administration. Washington, D.C. <http://flh.fhwa.dot.gov/programs/plh/discretionary/>. Accessed July 11, 2013.
- 141 "Grants" webpage. *National Scenic Byways Program* website. (n.d.). U.S. Department of Transportation. Washington, D.C. <http://bywaysonline.org/grants/>. Accessed July 11, 2013.
- 142 "Transportation Enhancement Activities" webpage. (n.d.). *Federal Highway Administration* website. U.S. Department of Transportation. Washington, D.C.

- [http://www.fhwa.dot.gov/environment/transportation\\_enhancements/guidance/te\\_provision\\_cfm](http://www.fhwa.dot.gov/environment/transportation_enhancements/guidance/te_provision_cfm). Accessed July 11, 2013.
- 143 Federal Transit Administration (2011). "Final Policy Statement on the Eligibility of Pedestrian and Bicycle Improvements under Federal Transit Law." *Federal Register*, Vol. 76, No. 161. Friday, August 19, 2011. Washington, D.C.  
<http://www.gpo.gov/fdsys/pkg/FR-2011-08-19/pdf/2011-21273.pdf>. Accessed July 11, 2013.
- 144 "Job Access and Reverse Commute Program (5316)" webpage. (n.d.). *Federal Transit Administration* website. U.S. Department of Transportation. Washington, D.C.  
[http://www.fta.dot.gov/grants/13093\\_3550.html](http://www.fta.dot.gov/grants/13093_3550.html). Accessed July 11, 2013.
- 145 "New Freedom Program (5317)" webpage. (n.d.). *Federal Transit Administration* website. U.S. Department of Transportation. Washington, D.C.  
[http://www.fta.dot.gov/grants/13093\\_3549.html](http://www.fta.dot.gov/grants/13093_3549.html). Accessed July 11, 2013.
- 146 "Paul S. Sarbanes Transit in Parks Program (5320)" webpage. (n.d.). *Federal Transit Administration* website. U.S. Department of Transportation. Washington, D.C.  
[http://fta.dot.gov/grants/13094\\_6106.html](http://fta.dot.gov/grants/13094_6106.html). Accessed July 11, 2013.
- 147 "Fact Sheets on Highway Provisions" webpage. (n.d.). *Federal Highway Administration* website. U.S. Department of Transportation. Washington, D.C.  
<http://www.fhwa.dot.gov/safetealu/factsheets/highpriproj.htm>. Accessed July 11, 2013.
- 148 *Safe Routes* website. (n.d.). National Center for Safe Routes to School. Chapel Hill, NC.  
<http://www.saferoutesinfo.org/>. Accessed July 11, 2013.
- 149 "Fact Sheets on Highway Provisions" webpage. (n.d.). *Federal Highway Administration* website. U.S. Department of Transportation. Washington, D.C.  
<http://www.fhwa.dot.gov/safetealu/factsheets/stp.htm>. Accessed July 11, 2013.
- 150 League of American Bicyclists and Alliance for Biking & Walking (n.d.). *Tools to Increase Biking and Walking Advocacy Awareness: Houston, TX, Funding Profile*. Washington, D.C.  
[http://www.bikeleague.org/sites/lab.huang.radicaldesigns.org/files/houston\\_funding\\_profile\\_final\\_compress.pdf](http://www.bikeleague.org/sites/lab.huang.radicaldesigns.org/files/houston_funding_profile_final_compress.pdf). Accessed July 11, 2013.
- 151 "Congestion Mitigation and Air Quality Improvement (CMAQ) Program" webpage. (n.d.). *Federal Highway Administration* website. U.S. Department of Transportation. Washington, D.C. [http://www.fhwa.dot.gov/environment/air\\_quality/cmaq/](http://www.fhwa.dot.gov/environment/air_quality/cmaq/). Accessed July 11, 2013.
- 152 "Section 402 State and Community Highway Safety Grant Program" webpage. (n.d.). *Governors Highway Safety Association* website. Governors Highway Safety Association, Washington, D.C. <http://www.ghsa.org/html/stateinfo/programs/402.html>. Accessed July 11, 2013.
- 153 "Highway Safety Improvement Program (HSIP)" webpage. (n.d.). *Federal Highway Administration* website. U. S. Department of Transportation, Washington, D.C.  
<http://safety.fhwa.dot.gov/hsip/>. Accessed July 11, 2013.
- 154 Texas Parks and Wildlife Department (n.d.). "Recreation Grant Programs" webpage. *Texas Parks & Wildlife* website. Austin, Texas. <http://www.tpwd.state.tx.us/business/grants/trpa/>. Accessed July 11, 2013.
- 155 "TIGER Grants" webpage. (n.d.). *U.S. Department of Transportation* website. Washington, D.C. <http://www.dot.gov/tiger/>. Accessed July 11, 2013.

- 156 *EECBG Program Notice 10-021* (2011). U.S. Department of Energy, Washington, D.C. [http://www1.eere.energy.gov/wip/pdfs/eeecbg\\_10-021\\_eigibility\\_guidance\\_010411.pdf](http://www1.eere.energy.gov/wip/pdfs/eeecbg_10-021_eigibility_guidance_010411.pdf). Accessed July 11, 2013.
- 157 Texas Department of Agriculture webpage. (n.d.). Community Development Fund Application and Guide. <http://www.texasagriculture.gov/GrantsServices/RuralEconomicDevelopment/RuralCommunityDevelopmentBlockGrantCDBG/CDBGResources/Applications/CommunityDevelopmentFundApplicationGuide.aspx>. Accessed July 14, 2013.
- 158 “Walk Well Texas” webpage. (n.d.). *Texas Citizen Fund* website. Texas Citizen Fund, Austin, Texas. <http://www.texascitizenfund.org/walkwell-texas>. Accessed July 11, 2013.
- 159 “Free Pedestrian Safety Assessments for California Communities” webpage. (n.d.). *Technology Transfer Program* website. ITS Berkeley, University of California at Berkeley, Berkeley, California. <http://www.techtransfer.berkeley.edu/pedsafety/>. Accessed July 11, 2013.
- 160 “Grants” webpage. (n.d.). *Florida Department of Transportation* website. Florida Department of Transportation, Tallahassee, Florida. <http://www.dot.state.fl.us/safety/3-Grants/Grants-Home.shtm>. Accessed July 11, 2013.
- 161 “Transportation Alternatives Program” webpage. (n.d.). *Maryland Department of Transportation State Highways Administration* website. Maryland Department of Transportation, Baltimore, Maryland. <http://www.roads.maryland.gov/index.aspx?pageid=144>. Accessed July 11, 2013.
- 162 Lindsay, D. (2011). “Police Grants to Protect Pedestrians,” *City of Pittsfield, Massachusetts*. [http://www.berkshireeagle.com/ci\\_18704269](http://www.berkshireeagle.com/ci_18704269). Accessed July 14, 2013.
- 163 “Division of Bicycle and Pedestrian Transportation” webpage. (n.d.). *North Carolina Department of Transportation* website. North Carolina Department of Transportation, Raleigh, North Carolina. <http://www.ncdot.gov/bikeped/>. Accessed July 11, 2013.
- 164 Washington Traffic Safety Commission (2013). *Washington Traffic Safety Commission*, Olympia, Washington. <http://www.wtsc.wa.gov>. Accessed July 11, 2013.
- 165 “Grants” webpage. *RWJF* website. Robert Wood Johnson Foundation, Princeton, New Jersey. <http://www.rwjf.org/grants/>. Accessed July 11, 2013.
- 166 “AARP Foundation Grants” webpage. (n.d.). AARP, Washington, D.C. <http://www.aarp.org/aarp-foundation/Grants-Administration/>. Accessed July 11, 2013.
- 167 KidCommute, Inc. (2011). *Boltage*. Webpage <http://www.boltage.org/>. Accessed July 11, 2013.
- 168 Fitzpatrick, K., S. Turner, M. Brewer, P. Carlson, N. Lalani, B. Ullman, N. Trout, E. Park, D. Lord, and J. Whitacre (2006). *Improving Pedestrian Safety at Unsignalized Crossings: Appendices B to O*. TCRP Web-Only Document 31/NCHRP Web-Only Document 91. Transportation Research Board, Washington, D.C. [http://onlinepubs.trb.org/onlinepubs/nchrp/nchrp\\_w91.pdf](http://onlinepubs.trb.org/onlinepubs/nchrp/nchrp_w91.pdf).
- 169 Furst, A. (2008). “MUTCD- Interim Approval for Optional Use of Rectangular Rapid Flashing Beacons (IA-11).” U.S. Department of Transportation Federal Highway Administration Memorandum, July 16, Washington, D.C. [http://mutcd.fhwa.dot.gov/resources/interim\\_approval/ia11/fhwamemo.htm](http://mutcd.fhwa.dot.gov/resources/interim_approval/ia11/fhwamemo.htm). Accessed July 9, 2013.



- 170 Pisano, P. (2009). R-376(I) – RRFB Overhead Mounting. U.S. Department of Transportation Federal Highway Administration *Memorandum, December 9*, Washington, D.C. [http://mutcd.fhwa.dot.gov/resources/interpretations/4\\_376.htm](http://mutcd.fhwa.dot.gov/resources/interpretations/4_376.htm). Accessed on July 9, 2013.
- 171 American Association of State Highway and Transportation Officials (2011). *A Policy on Geometric Design of Highways and Streets*. AASHTO, Washington, D.C.
- 172 Texas Transportation Code – Section 552.003. Pedestrian Right-of-Way at Crosswalk. <http://law.onecle.com/texas/transportation/552.003.00.html>. Accessed July 15, 2013.
- 173 Fatality Analysis Reporting System (FARS) online query system. (2012). Washington, D.C.: U.S. Department of Transportation, National Highway Traffic Safety Administration.
- 174 National Highway Traffic Safety Administration (2008). National Pedestrian Crash Report, DOT HS 810 968, Washington, D.C.: U.S. Department of Transportation, June.
- 175 NHTSA Traffic Safety Facts (2010 Data): Pedestrians. DOT HS811 625. <http://www-nrd.nhtsa.dot.gov/Pubs/811625.pdf>. Accessed August 2012.
- 176 U.S. Census Bureau, *American FactFinder*. <http://factfinder2.census.gov/faces/nav/jsf/pages/searchresults.xhtml?refresh=t>. April 4 2013.
- 177 Chakravarthy, B., C.L. Anderson, J. Ludlow, S. Lotfipour, and F.E. Vaca (2010). *The Relationship of Pedestrian Injuries to Socioeconomic Characteristics in a Large Southern California County*. *Traffic Injury Prevention*, 11:508–513.
- 178 Johnson, C.D. (1997). Pedestrian Fatalities on Interstate Highways: Characteristics and Countermeasures. In *Transportation Research Record 1578*, Transportation Research Board, National Research Council, Washington, D.C., pp. 23–29.
- 179 NHTSA Fatality Analysis Reporting System. <http://www-fars.nhtsa.dot.gov>. Accessed April 2013.
- 180 FHWA – Office of Highway Policy Information. <http://www.fhwa.dot.gov/policyinformation/quickfinddata/qftravel.cfm>. Accessed April 2013.
- 181 Texas Department of State Health Services. <http://www.dshs.state.tx.us/chs/popdat/detailX.shtm>. Accessed April 2013.
- 182 U.S. Department of Commerce, United States Census Bureau. <http://factfinder2.census.gov/faces/nav/jsf/pages/searchresults.xhtml?refresh=t>. Accessed April 2013.
- 183 Pinkerton, J. Houston Drivers Seldom Charged in Pedestrian Crashes. *The Houston Chronicle*, article dated August 1, 2011. <http://www.chron.com/news/houston-texas/article/Houston-drivers-seldom-charged-in-pedestrian-2082000.php>. Accessed April 2013.
- 184 Transportation Planning and Programming Division. Highway Designation File: Interstate Highway No. 635. Texas Department of Transportation. <https://www.txdot.gov/tpp/hwy/ih/ih0635.htm>. Accessed July 24, 2013.
- 185 Transportation Planning and Programming Division. Highway Designation File: Interstate Highway No. 410. Texas Department of Transportation. <https://www.txdot.gov/tpp/hwy/ih/ih0410.htm>. Accessed July 24, 2013.

- 186 Transportation Planning and Programming Division. Highway Designation File: Interstate Highway No. 35. Texas Department of Transportation.  
<https://www.txdot.gov/tpp/hwy/ih/ih0035.htm>. Accessed July 24, 2013.
- 187 Transportation Planning and Programming Division. Highway Designation File: Interstate Highway No. 45. Texas Department of Transportation.  
<https://www.txdot.gov/tpp/hwy/ih/ih0045.htm>. Accessed July 24, 2013.
- 188 Transportation Planning and Programming Division. Highway Designation File: U.S. Highway No. 75. Texas Department of Transportation.  
<https://www.txdot.gov/tpp/hwy/us/us0075.htm>. Accessed July 24, 2013.
- 189 Transportation Planning and Programming Division. Highway Designation File: Interstate Highway No. 30. Texas Department of Transportation.  
<https://www.txdot.gov/tpp/hwy/ih/ih0030.htm>. Accessed July 24, 2013.
- 190 Transportation Planning and Programming Division. Highway Designation File: U.S. Highway No. 175. Texas Department of Transportation.  
<https://www.txdot.gov/tpp/hwy/us/us0175.htm>. Accessed July 24, 2013.
- 191 Transportation Planning and Programming Division. Highway Designation File: Interstate Highway No. 10. Texas Department of Transportation.  
<https://www.txdot.gov/tpp/hwy/ih/ih0010.htm>. Accessed July 24, 2013.
- 192 Transportation Planning and Programming Division. Highway Designation File: Interstate Highway No. 20. Texas Department of Transportation.  
<https://www.txdot.gov/tpp/hwy/ih/ih0020.htm>. Accessed July 24, 2013.
- 193 Transportation Planning and Programming Division. Highway Designation File: U.S. Highway No. 59. Texas Department of Transportation.  
<https://www.txdot.gov/tpp/hwy/us/us0059.htm>. Accessed July 24, 2013.
- 194 Kuhnert, P.M., K.-A. Do, and R. McClure. (2000). Combining Non-Parametric Models with Logistic Regression: an Application to Motor Vehicle Injury Data. *Computational Statistics and Data Analysis*, Vol. 34, No. 3, pp. 371–386.
- 195 Karlaftis, M.G., and I. Golias (2002). Effects of Road Geometry and Traffic Volumes on Rural Roadway Accident Rates. *Accident Analysis & Prevention*, Vol. 34, No. 3, pp. 357–365.
- 196 Montella, A., M. Aria, A. D’Ambrosio, and F. Mauriello (2011). Data-Mining Techniques for Exploratory Analysis of Pedestrian Crashes. In *Transportation Research Record 2237*, Transportation Research Board, National Research Council, Washington, D.C., pp. 107–116.
- 197 Chang, L., and W. Chen (2005). Data Mining of Tree-Based Models to Analyze Freeway Accident Frequency. *Journal of Safety Research*, Vol. 36, No. 4, pp. 365–375.
- 198 Chang, L., and H. Wang. (2006). Analysis of Traffic Injury Severity: An Application of Non-Parametric Classification Tree Techniques. *Accident Analysis & Prevention*, Vol. 38, No. 5, pp. 1019–1027.
- 199 Kashani, A.T., and A.S. Mohaymany (2011). Analysis of Traffic Injury Severity on Two-Lane, Two-Way Rural Road Based on Classification Tree Models. *Safety Science*, Issue 49, pp. 1314–1320.

- 200 Chang, L-Y, and J-T Chien (2013). Analysis of Driver Injury Severity in Truck-Involved Accidents Using a Non-Parametric Classification Tree Model. *Safety Science*, Issue 51, pp. 17–22.
- 201 Breiman, L., J.H. Friedman, R.A. Olshen, and C.J. Stone (1984). *Classification and Regression Trees*. Wadsworth International Group, Belmont, California.
- 202 IBM Corp. Released 2012. IBM SPSS Statistics for Windows, Version 21.0. Armonk, NY: IBM Corp.
- 203 Kim, J., G.F. Ulfarsson, V.N. Shankar, and S. Kim (2008). Age and Pedestrian Injury Severity in Motor-Vehicle Crashes: A Heteroskedastic Logit Analysis. *Accident Analysis & Prevention*, Vol. 40, No. 5, pp. 1695–1702.
- 204 Kim, J., G.F. Ulfarsson, V.N. Shankar, and F. Mannering (2010). A Note on Modeling Pedestrian-Injury Severity in Motor-Vehicle Crashes with the Mixed Logit Model. *Accident Analysis & Prevention*, Vol. 42, No. 6, pp. 1751–1758.
- 205 Holubowycz, O.T. (1995). Age, Sex, and Blood Alcohol Concentration of Killed and Injured Pedestrians. *Accident Analysis & Prevention*, Vol. 27, No. 3, pp. 417–422.
- 206 Fitzpatrick, K., and E.S. Park (2009). Safety Effectiveness of HAWK Pedestrian Treatment. In *Transportation Research Record 2140*, Transportation Research Board, National Research Council, Washington, D.C., pp. 214–223.
- 207 Lefler, D.E., and H.C. Gabler (2004). The Fatality and Injury Risk of Light Truck Impacts with Pedestrians in the United States. *Accident Analysis & Prevention*, Vol. 36, No. 2, pp. 295–304.
- 208 “Focused Approach to Safety” webpage. *FHWA Safety website*. <http://safety.fhwa.dot.gov>. Accessed July 22, 2013.





**Texas A&M Transportation Institute**  
**College Station, TX 77843-3135**  
**979-845-1734**  
**<http://tti.tamu.edu>**