

# Guidelines on Design and Construction of High Performance Thin HMA Overlays

Cindy K. Estakhri  
Tommy Blackmore  
Tom Scullion

Published: August 2016

<http://tti.tamu.edu/documents/5-5598-05-WS2>



# WORKSHOP NOTES

## Guidelines on the Use and Inspection of Thin Surface Mixes in TxDOT's Maintenance and Pavement Preservation Programs



### WORKSHOP INSTRUCTORS:

Tom Scullion, PE  
Tommy Blackmore  
Cindy Estakhri, PE

April 2016





# Class Overview

## Part I – Morning 10:00 to noon

- Why Thin Overlays
- Types of Thin Overlays
- Materials Selection
- Specifications
- Mix Design
- Site Selection
- Houston Candidates

## Part II – Afternoon 1:00-3:00

- Project Inspection
- Tack Coat/Bonding Underseals
- Mixture Placement and Compaction
  - Weather/Temperature
  - Good Practices
  - Haul Distances
  - Managing Windrows
- Acceptance Testing



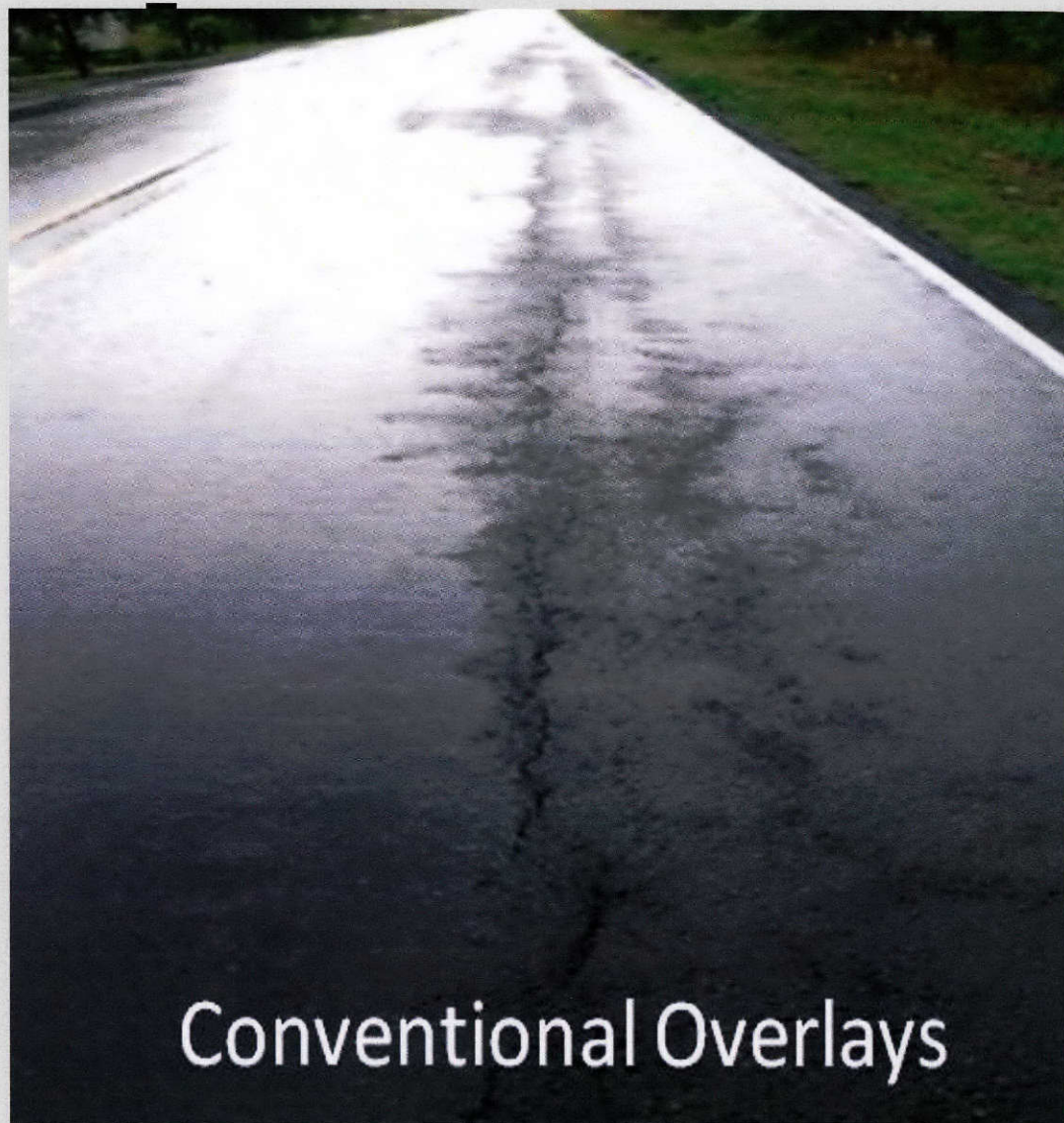



## Statewide Cost-Savings - TOM vs. Conventional Overlays

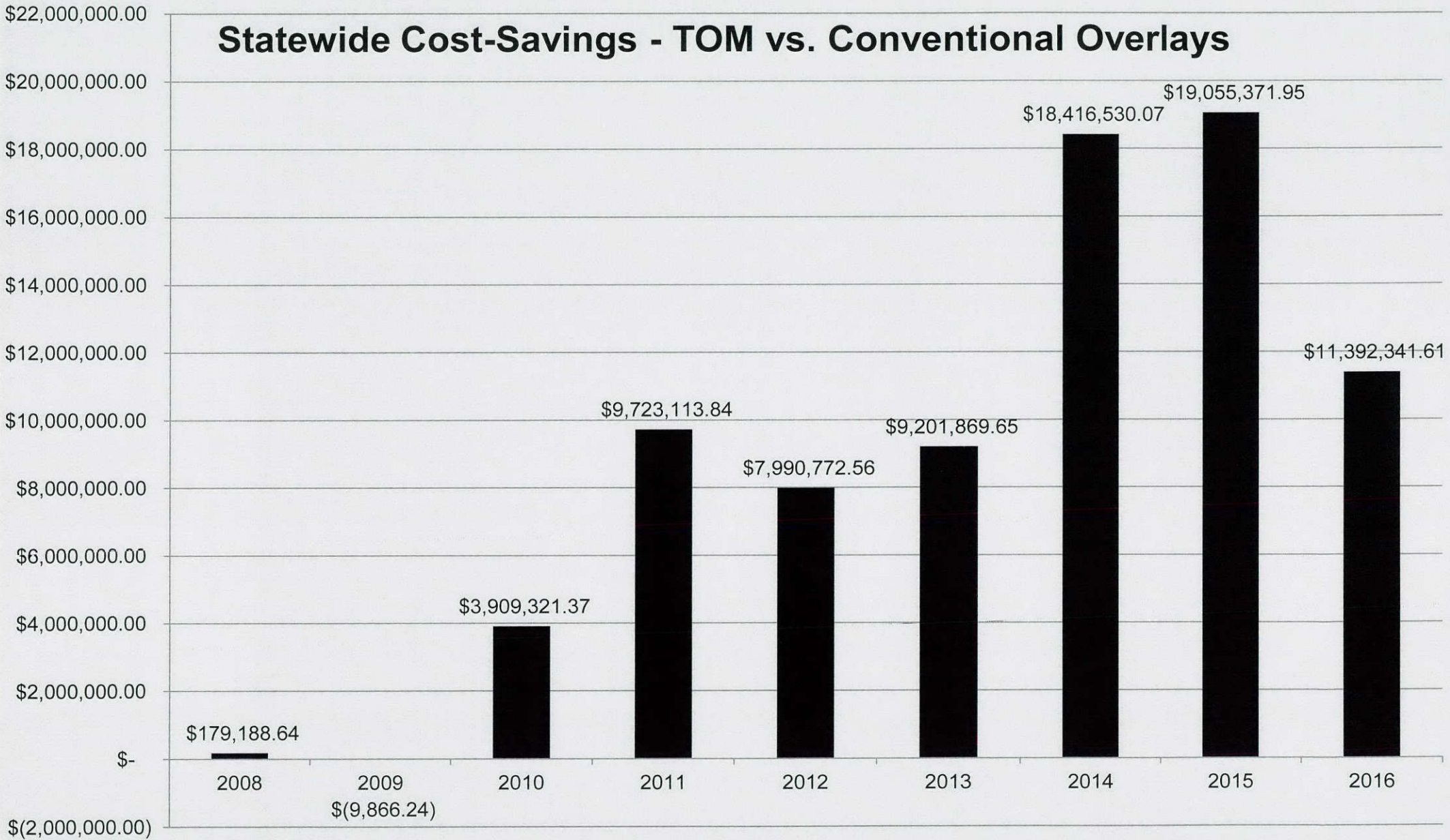



Rut/Crack resistance

Skid resistance

SAC B – High 30's to Mid 40's

SAC A – High 40's to Low 50's

Smoothness (IRI improvement)

Typically 25-35% improvement –  
depends on pre-existing conditions

Sound Abatement

2 to 6 times reduction in noise

96.5-98dB = PFC

IH-35 (ADT >100k):  
Before/After

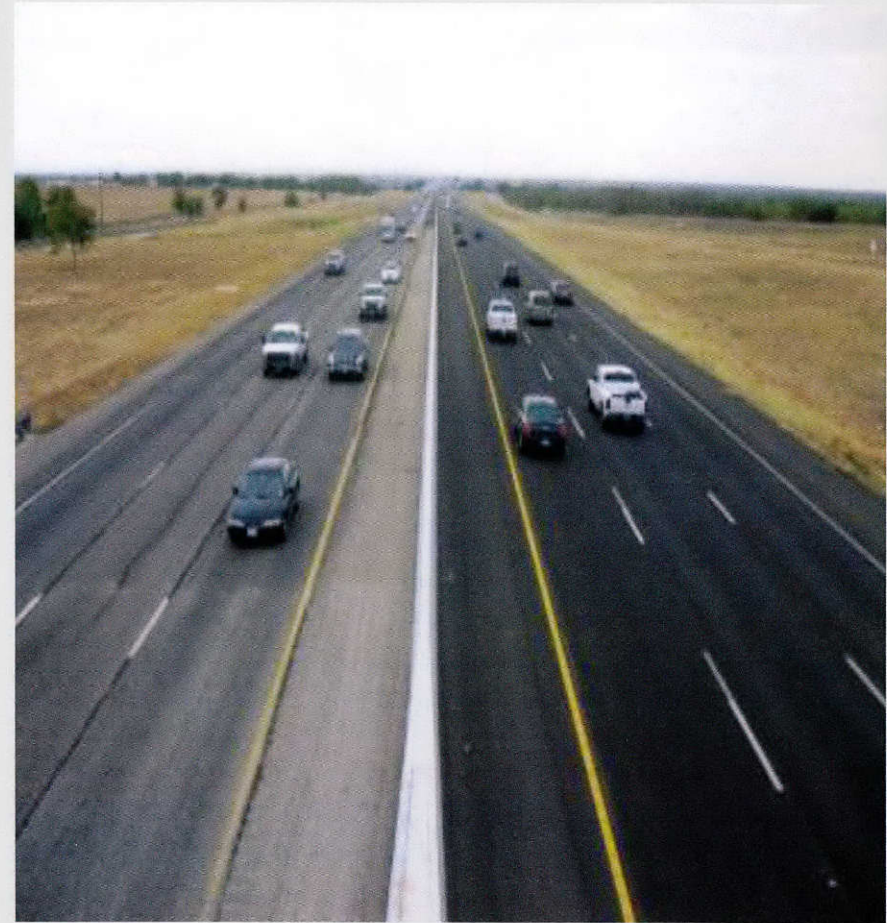



# Long-Term Performance – TOMs, Austin District

## Long-Term Distress Performance (2008-2014)

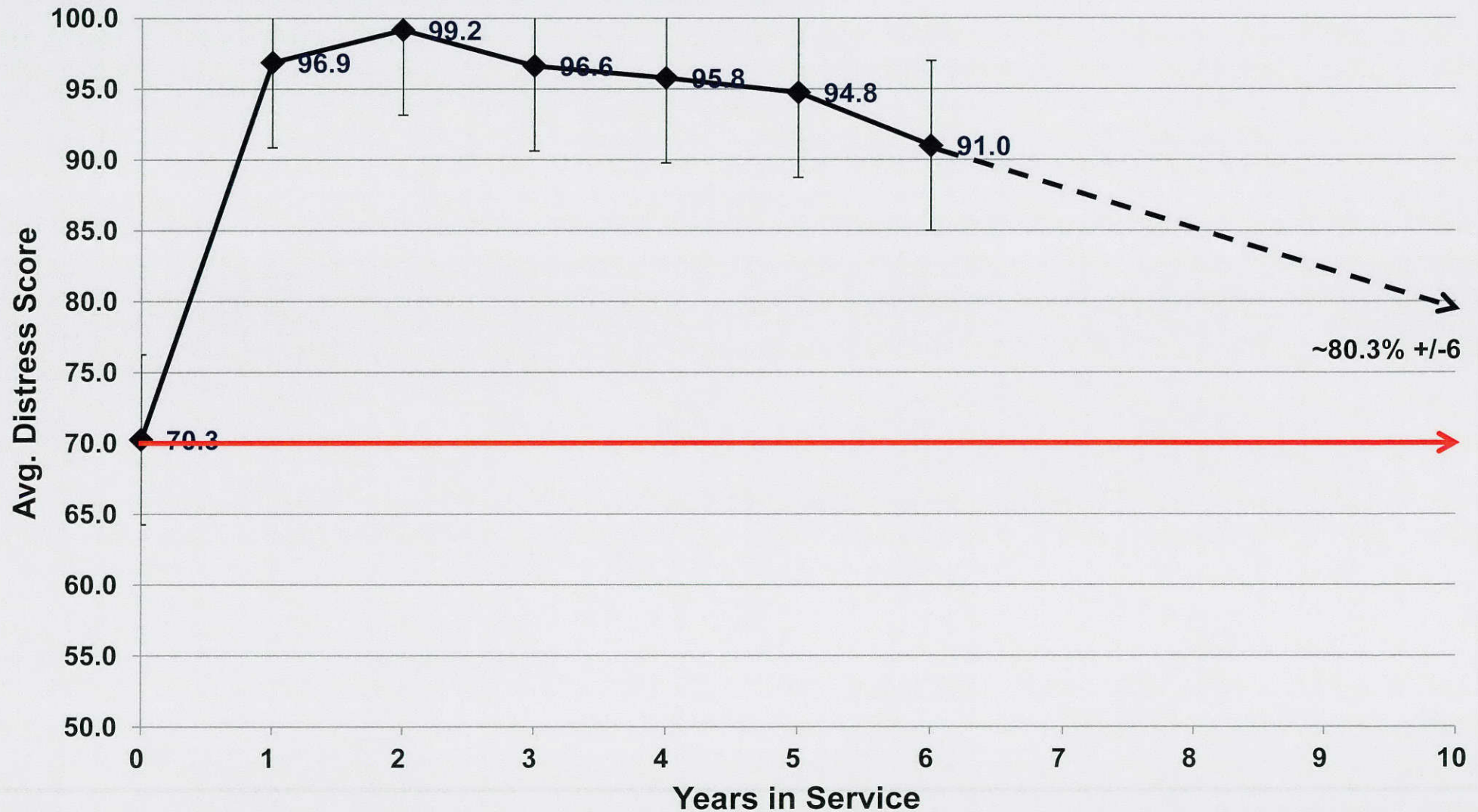



# Types of Thin Overlays

Transportation  
Institute



# Aggregate Components



Grade 5 (1 / 4 inch)



Screenings



# Mixture Types

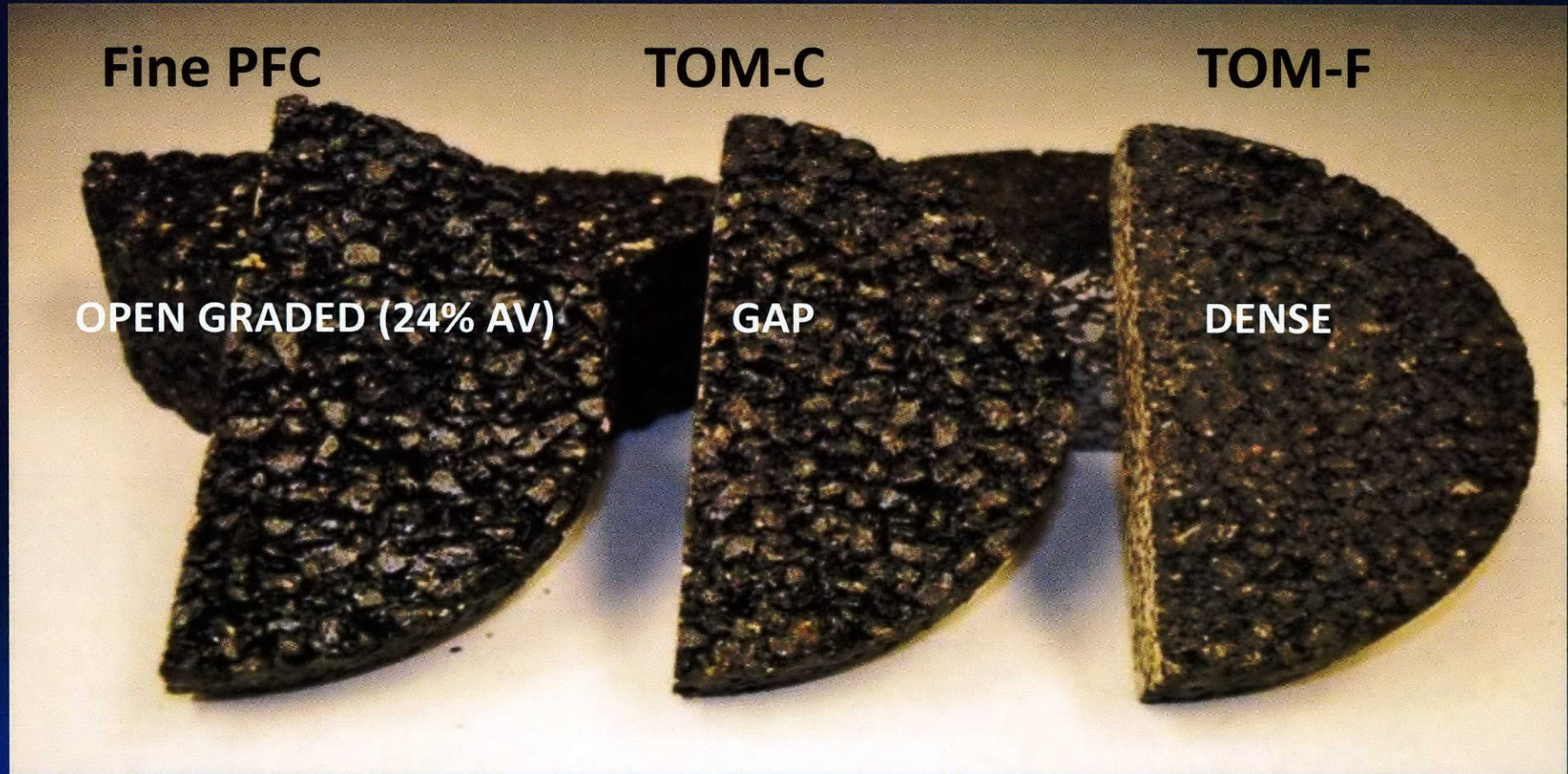

- 30% Cost savings over traditional mixes - lifts of 1 inch or less
- Pass Rutting (HWTT) and Cracking (OT) performance tests
- Mandate PG 76-22 SAC A Grade 5 Rock + Screenings
- Structurally Sound Pavements ONLY



# Key Components of Mix Design and Material Properties

- High-quality aggregate – SAC A for high volume roads
- PG 70 or 76 (Polymer Modified binders)
- RAP and RAS (shingles) not allowed
- Minimum binder content ( Over 6%)
- Pay for binder separately ??
- Performance test requirements
- Warm mix additives (for long haul distances)



# SAC A and SAC B blending

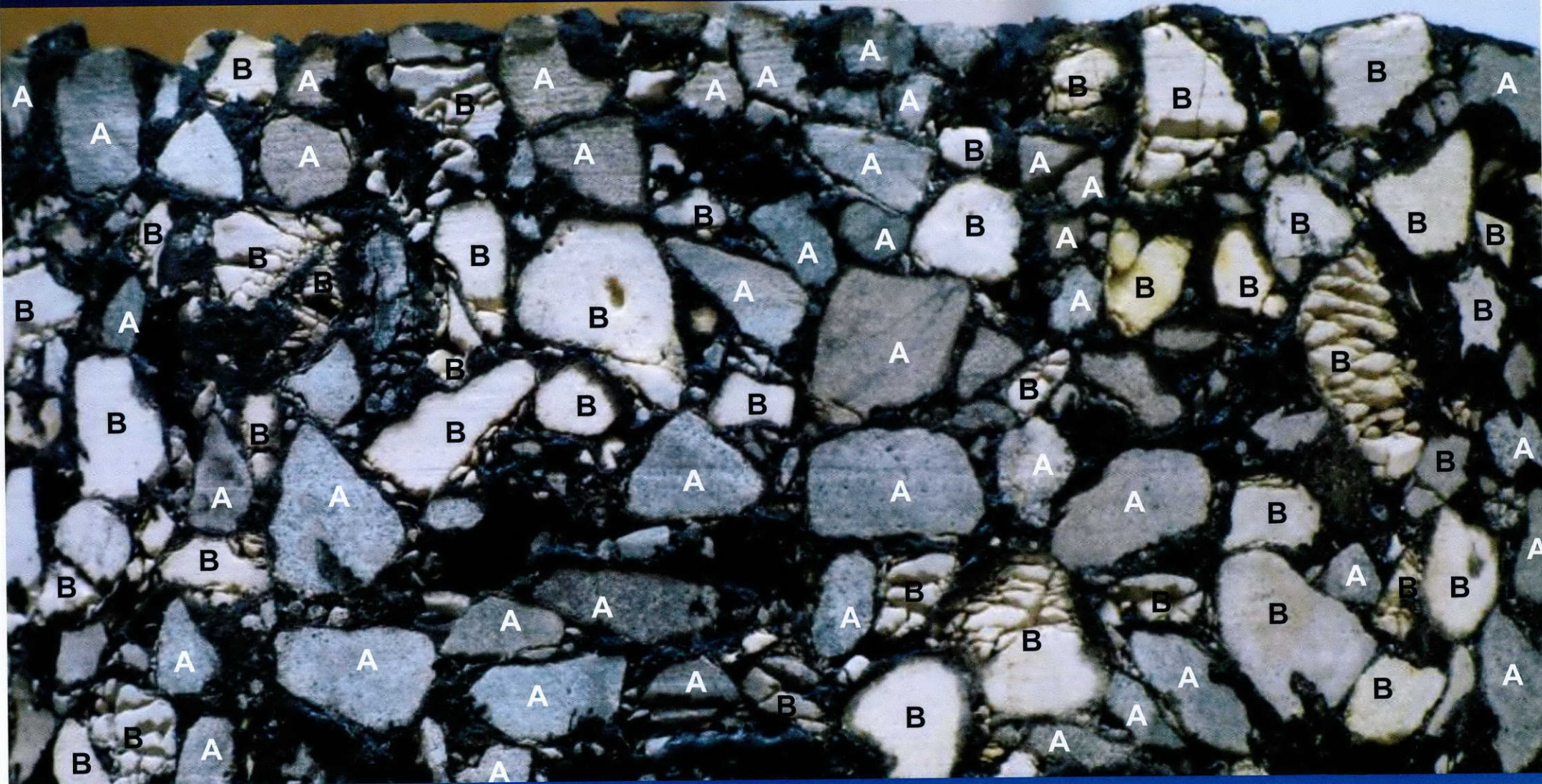



# Mix Design and Specifications

TRANSPORTATION  
Institute



# TOM-C and TOM-F Specification

## Item 347

### Thin Overlay Mixtures (TOM)



#### 1. DESCRIPTION

Construct a thin surface course composed of a compacted mixture of aggregate and asphalt binder mixed hot in a mixing plant. Produce a thin surface course with a minimum lift thickness of 1/2 in. for TOM Type F mixture and 3/4 in. for TOM Type C mixture.



# Higher Aggregate Quality Requirements

**Table 1**  
**Aggregate Quality Requirements**

Property	Test Method	Requirement
<b>Coarse Aggregate</b>		
SAC	Tex-499-A (AQMP)	A <sup>1</sup>
Deleterious material, %, Max	Tex-217-F, Part I	1.5
Decantation, %, Max	Tex-217-F, Part II	1.5
Micro-Deval abrasion, %	Tex-461-A	Note <sup>2</sup>
Los Angeles abrasion, %, Max	Tex-410-A	30
Magnesium sulfate soundness, 5 cycles, %, Max	Tex-411-A	20
Crushed face count, <sup>3</sup> %, Min	Tex-460-A, Part I	95
Flat and elongated particles @ 5:1, %, Max	Tex-280-F	10
<b>Fine Aggregate</b>		
Linear shrinkage, %, Max	Tex-107-E	3
<b>Combined Aggregate<sup>4</sup></b>		
Sand equivalent, %, Min	Tex-203-F	45

1. Surface Aggregate Classification of "A" is required unless otherwise shown on the plans.
2. Used to estimate the magnesium sulfate soundness loss in accordance with Section 347.2.1.1.2., "Micro-Deval Abrasion."
3. Only applies to crushed gravel.
4. Aggregates, without mineral filler or additives, combined as used in the job-mix formula (JMF).



# Thermal Imaging Requirement

- 4.7.1.1. **When Using a Thermal Imaging System.** The Contractor may pave any time the roadway is dry and the roadway surface temperature is at least 32°F; however, the Engineer may restrict the Contractor from paving surface mixtures if the ambient temperature is likely to drop below 32°F within 12 hr. of paving. Provide output data from the thermal imaging system to demonstrate to the Engineer that no recurring severe thermal segregation exists in accordance with Section 347.4.7.3.1.2., "Thermal Imaging System."



# Bogus delete this

~~4.7.1.1. **When Using a Thermal Imaging System.** The Contractor may pave any time the roadway is dry and the roadway surface temperature is at least 32°F; however, the Engineer may restrict the Contractor from paving surface mixtures if the ambient temperature is likely to drop below 32°F within 12 hr. of paving. Provide output data from the thermal imaging system to demonstrate to the Engineer that no recurring severe thermal segregation exists in accordance with Section 347.4.7.3.1.2., "Thermal Imaging System."~~



# Critical Requirement

4.7.2. **Tack Coat.** Clean the surface before placing the tack coat. The Engineer will set the rate between 0.04 and 0.10 gal. of residual asphalt per square yard of surface area. Apply a uniform tack coat at the specified rate

**Trackless Tack strongly recommended**



# Houston's Plan Notes 1 of 2

## **Item 347: Thin Overlay Mixture (TOM)**

Provide an asphalt binder PG 76-22. Substitution of the PG binder is not allowed.

Place mixture at the compacted lift thickness of one (1) inch.

Provide 100% SAC "A" aggregate. Blending of coarse aggregate is not allowed. A maximum of 25% SAC "B" screening material can be used.

Do not use RAP and RAS in the mixture.

A Pave-IR system or Thermal camera system is mandatory for this project. The contractor must demonstrate that the mixture is being placed with no severe thermal segregation.

Provide a mix which lasts more than 500 cycles in the Overlay Tester.

For breakdown rolling use two steel-wheel rollers working in tandem without excessive breakage of the aggregate and provide a smooth surface and uniform texture, keeping the rollers as close as possible to the lay-down machine. Do not use pneumatic-tire rollers. Use a steel wheel as the finish roller.



# Houston's Plan Notes 2 of 2

**Water flow measurements as per Tx Method 246 are mandatory for setting rolling patterns. The contractor must report the selected patterns to TxDOT and show that it meets the water flow requirements**

**[ftp://ftp.dot.state.tx.us/pub/txdot-info/cst/TMS/200-F\\_series/pdfs/bit246.pdf](ftp://ftp.dot.state.tx.us/pub/txdot-info/cst/TMS/200-F_series/pdfs/bit246.pdf)**

**Avoid excessive compaction where water flows of greater than 10 minutes are not allowed, the final surface must have acceptable macro-texture.**

**The tack coat must be a hot applied trackless tack.**

**All construction joints must be placed under the paint stripes between the lanes. (No joints near wheel paths)**

**Performance test will be required on all mix design and trial batch samples, for each mold 6 samples at optimum asphalt content at 7% air voids content each will be 6 inches in diameter by 2.4 inches thick (Hamburg sized samples). The samples are to be sent to the Texas Transportation Institute (TTI) for Hamburg Wheel Test and Overlay test. This work is subsidiary to the various bid items.**



# Typical Water Flow – 6 seconds for PFC

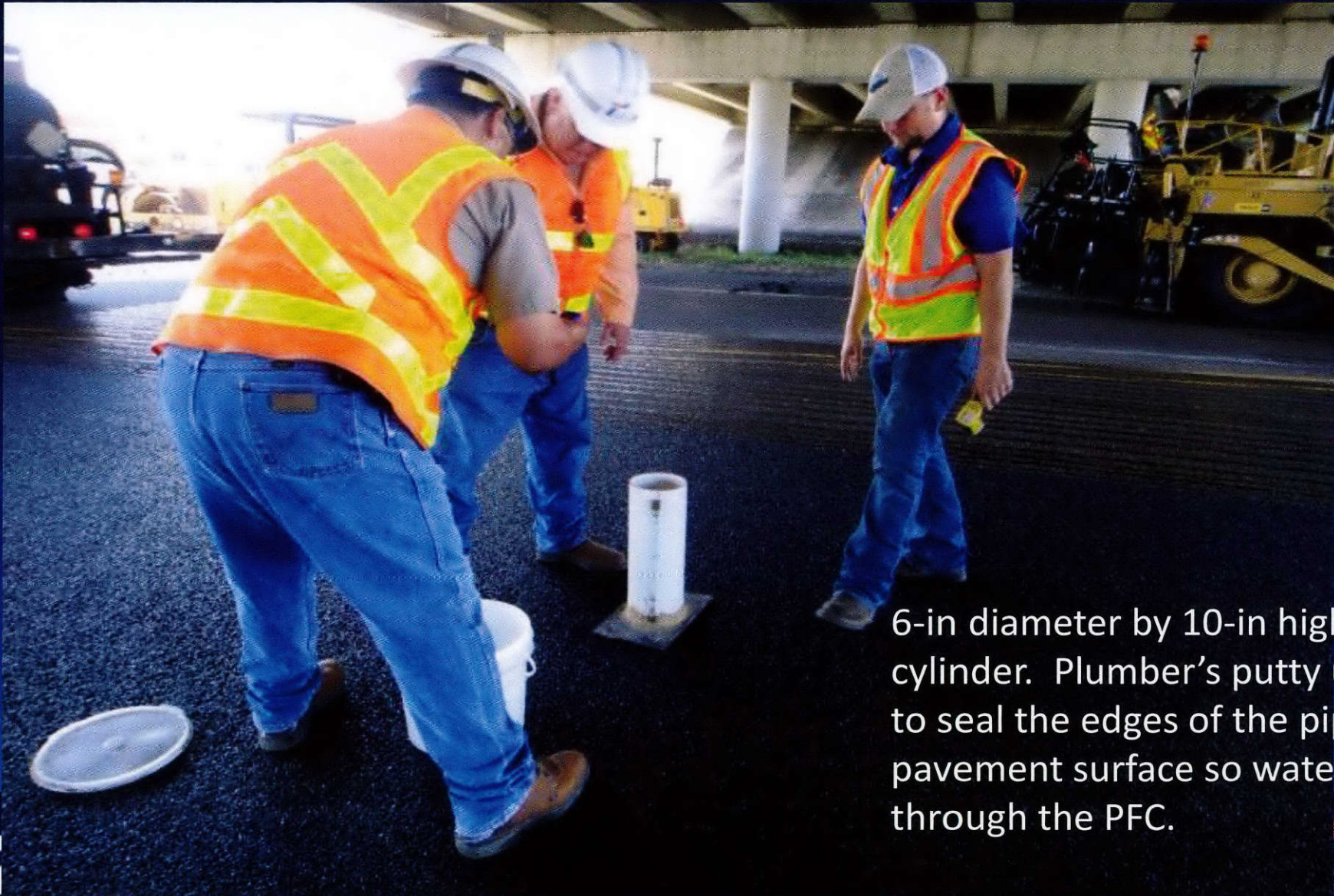

6-in diameter by 10-in high cylinder. Plumber's putty used to seal the edges of the pipe to pavement surface so water flows through the PFC.



# New Approaches to Mix Design

## Balancing Rutting and Reflection Cracking Requirements

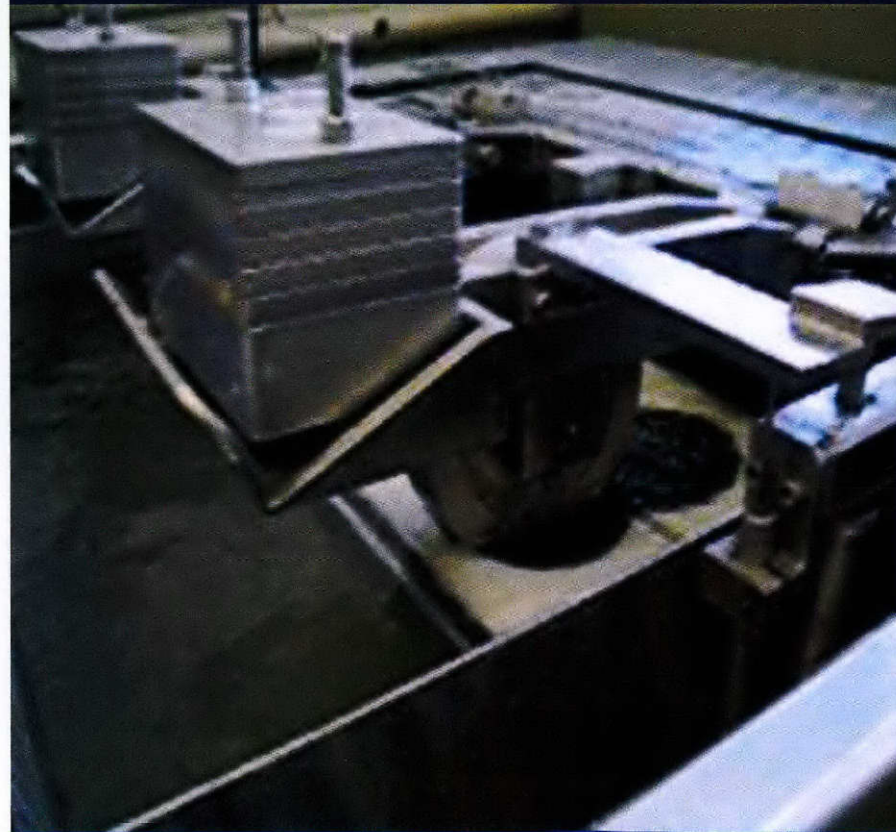

Rutting test

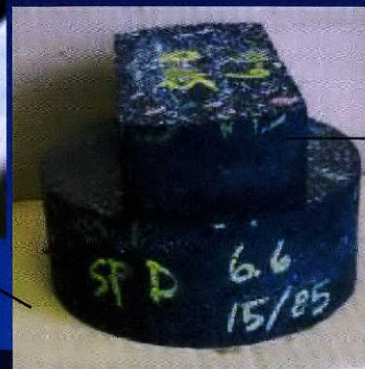

Standard prep

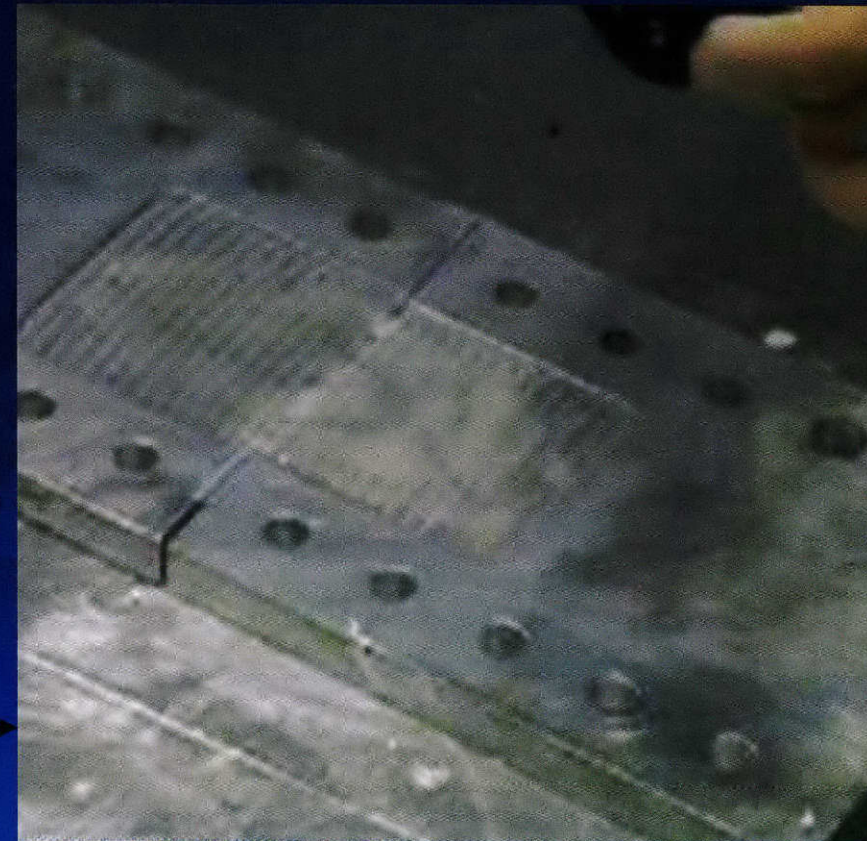

Reflection Cracking test



# Mix Design & Material Properties

## Laboratory Mixture Design Properties

Mixture Property	Test Method	Requirement
Target laboratory-molded density, % (TGC)	Tex 207 F	97.5 <sup>1</sup>
Design gyrations (N <sub>design</sub> for SGC)	Tex-241-F	50 <sup>2</sup>
Hamburg Wheel test, passes at 12.5 mm rut depth for PG 70 mixtures	Tex-242-F	15,000 Min
Hamburg Wheel test, passes at 12.5 mm rut depth for PG 76 mixtures	Tex-242-F	20,000 Min
Tensile strength (dry), psi.	Tex-226-F	85-200
Overlay test, number of cycles	Tex-248-F	300 Min
Drain-down, %	Tex-235-F	0.20 Max

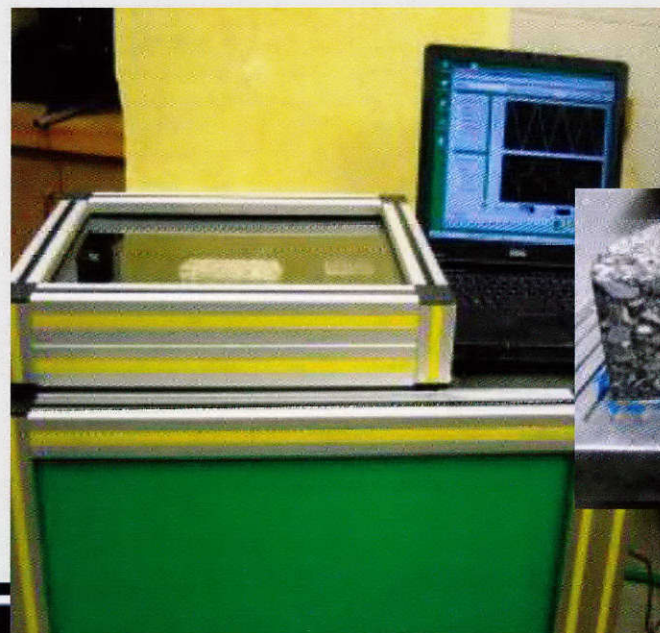
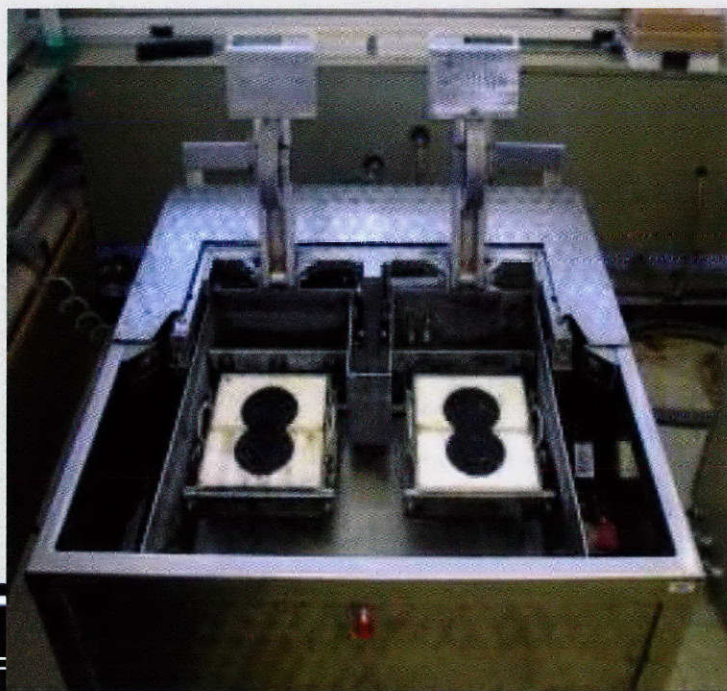



Century Asphalts TOM Mix for Houston  
HWTT = 5.4 and 3.9 mm OT = 1000 cycles





# Conventional vs. TOM Surface Mixes

<i>Properties</i>	<i>Conventional HMA</i>	<i>TOM-C</i>	<i>TOM-F</i>
Gradation	Dense	GAP	Dense
Polymer Modified AC	Maybe	Yes	Yes
High Quality Aggr.	Maybe	Yes	Yes
AC Content	~ 4.8 – 5.2%	6.0% min	6.5% min
RAP	Yes	No	No
RAS	Yes	No	No
Rutting Requirement	Yes	Yes	Yes
Cracking Requirement	No	Yes	Yes



# Fine PFC Specification

**Item 342**

**Permeable Friction Course (PFC)**



**1. DESCRIPTION**

Construct a hot-mix asphalt (HMA) surface course composed of a compacted permeable mixture of aggregate, asphalt binder, and additives mixed hot in a mixing plant.



**Table 4**  
**Master Gradation Limits (% Passing by Weight or Volume) and Laboratory Mixture Design Properties**

Sieve Size	PG 76 Mixtures		A-R Mixtures		Test Procedure
	Fine (PFC-F)	Coarse (PFC-C)	Fine (PFCR-F)	Coarse (PFCR-C)	
3/4"	-	100.0 <sup>1</sup>	100.0 <sup>1</sup>	100.0 <sup>1</sup>	Tex-200-F
1/2"	100.0 <sup>1</sup>	80.0-100.0	95.0-100.0	80.0-100.0	
3/8"	95.0-100.0	35.0-60.0	50.0-80.0	35.0-60.0	
#4	20.0-55.0	1.0-20.0	0.0-8.0	0.0-20.0	
#8	1.0-10.0	1.0-10.0	0.0-4.0	0.0-10.0	
#200	1.0-4.0	1.0-4.0	0.0-4.0	0.0-4.0	
<b>Mixture Properties</b>					
Asphalt binder content, %	6.0-7.0	6.0-7.0	8.0-10.0	7.0-9.0	-
Design gyrations (N <sub>design</sub> )	50	50	50	50	Tex-241-F
Lab-molded density, %	78.0 Max	82.0 Max	82.0 Max	82.0 Max	Tex-207-F
Hamburg Wheel test, <sup>2</sup> passes at 12.5 mm rut depth	10,000 Min <sup>3</sup>	Note <sup>2</sup>	Note <sup>2</sup>	Note <sup>2</sup>	Tex-242-F
Overlay tester, <sup>2</sup> number of cycles	200 Min	Note <sup>2</sup>	Note <sup>2</sup>	Note <sup>2</sup>	Tex-248-F
Drain-down, %	0.10 Max	0.10 Max	0.10 Max	0.10 Max	Tex-235-F
Fiber content, % by wt. of total PG 76 mixture	0.20 <sup>4</sup> -0.50	0.20 <sup>4</sup> -0.50	-	-	Calculated
Lime content, % by wt. of total aggregate	1.0 <sup>5</sup>	1.0 <sup>5</sup>	1.0 <sup>5</sup>	1.0 <sup>5</sup>	Calculated
CRM content, % by wt. of A-R binder	-	-	15.0 Min	15.0 Min	Calculated
Boil test <sup>6</sup>	-	-	-	-	Tex-530-C
Cantabro loss, %	20.0 Max	20.0 Max	20.0 Max	20.0 Max	Tex-245-F

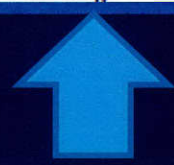



# Fine PFC vs Conventional PFC

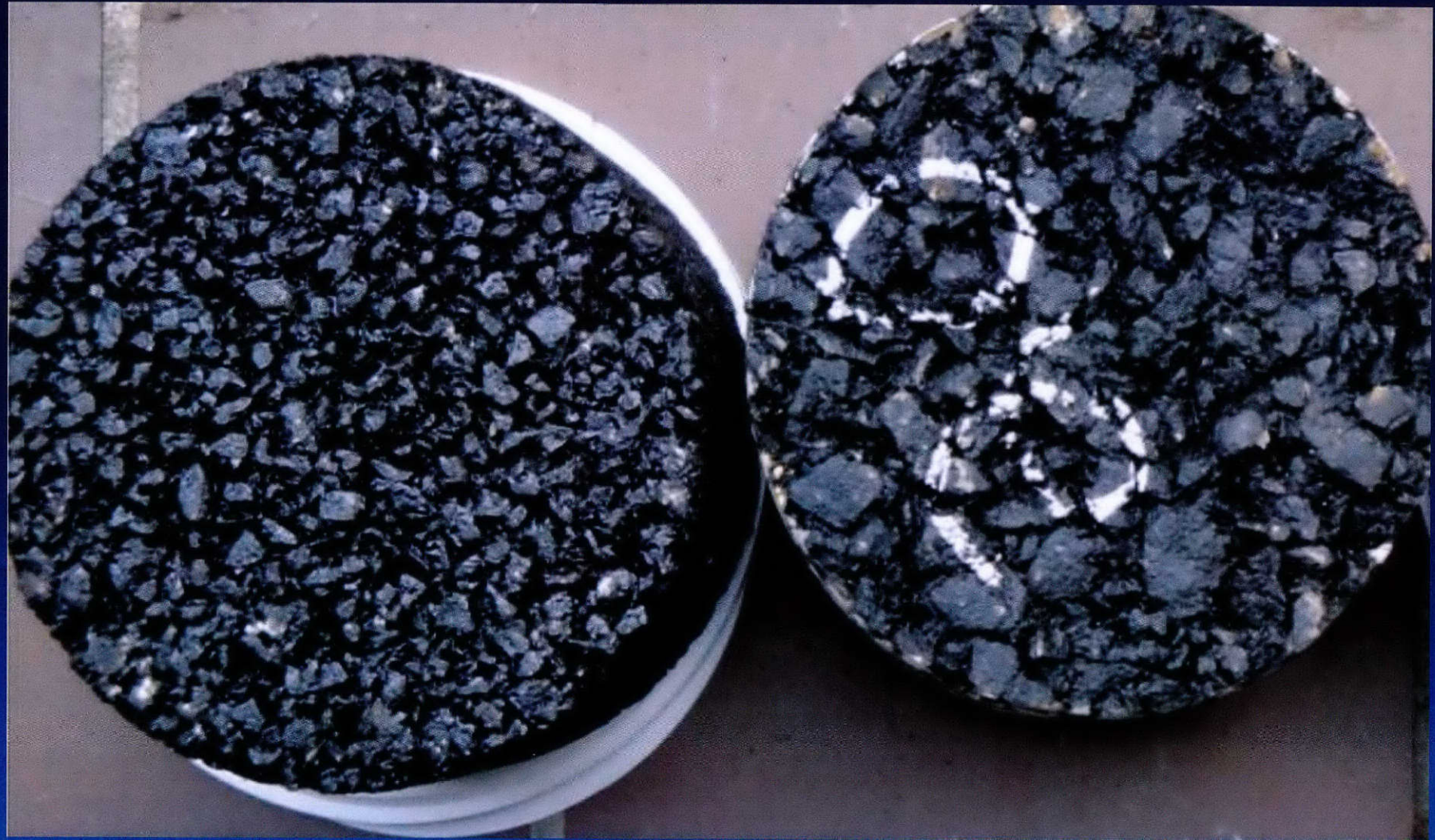







# Good Candidates for TOM C –

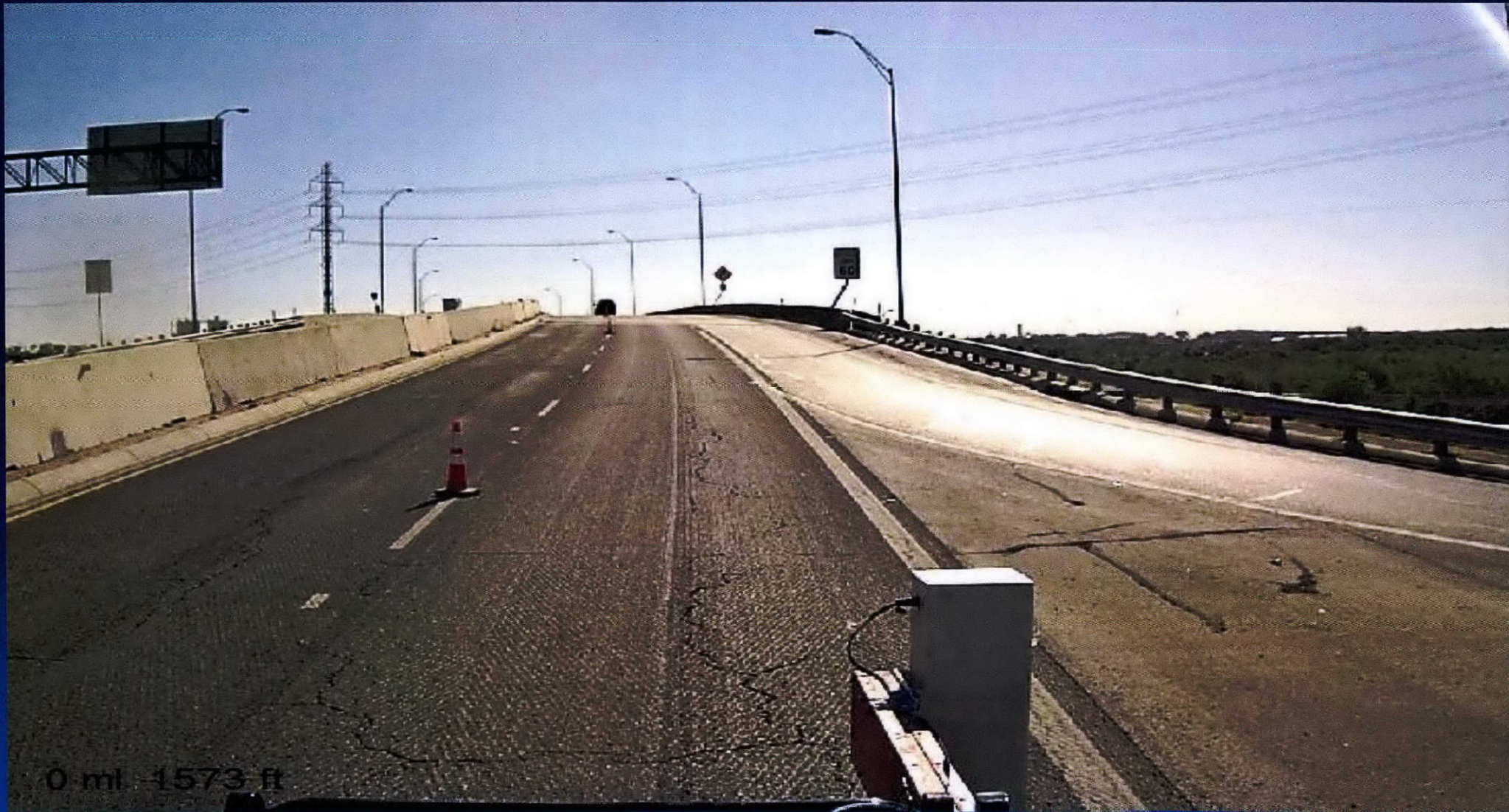



# District Use of TOM-C

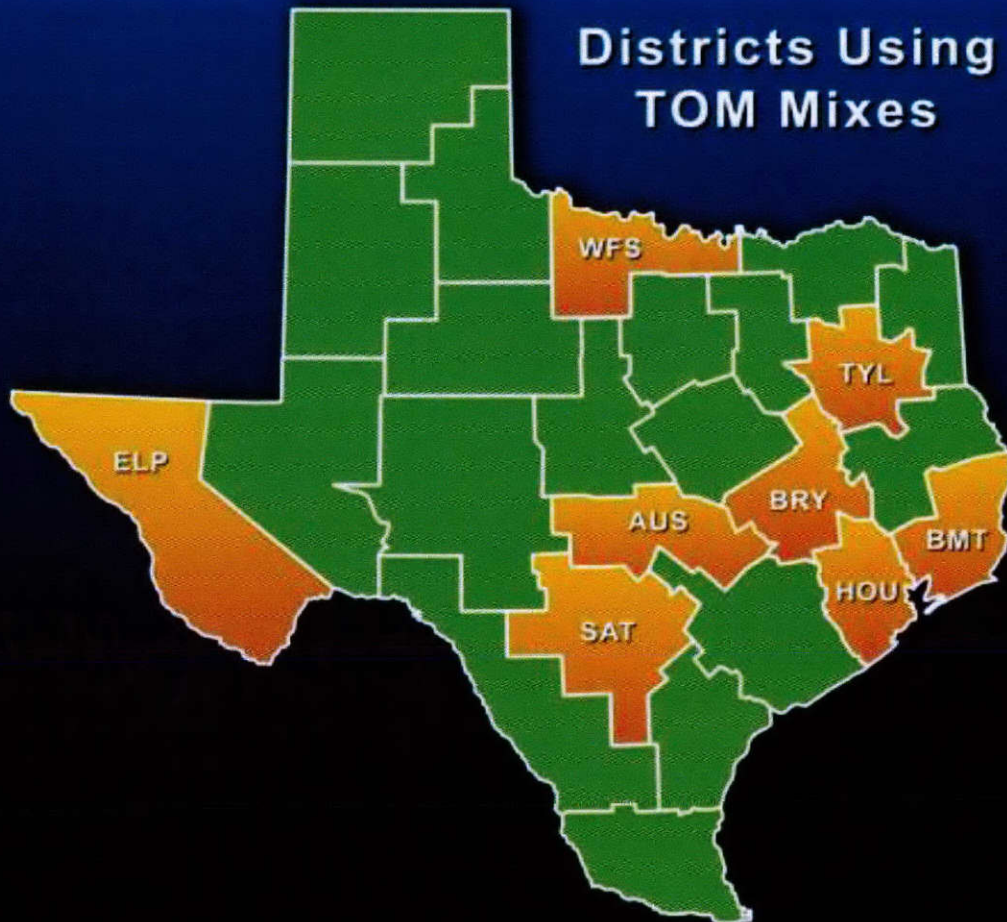

## Houston Projects

- US 59 Main lanes
- US 59 Frontage Roads
- IH 45
- FM 1488
- FM 1887

## Upcoming

- FM 1960



# Successful High Volume Traffic TOM-C Applications





# Successful Low



# Thinlay:

## A Win-Win Deep in the Heart of Texas

Low life-cycle costs, skid resistance, and noise reduction make this pavement popular with everyone

By Kelli Reyna and Martha K. Silver

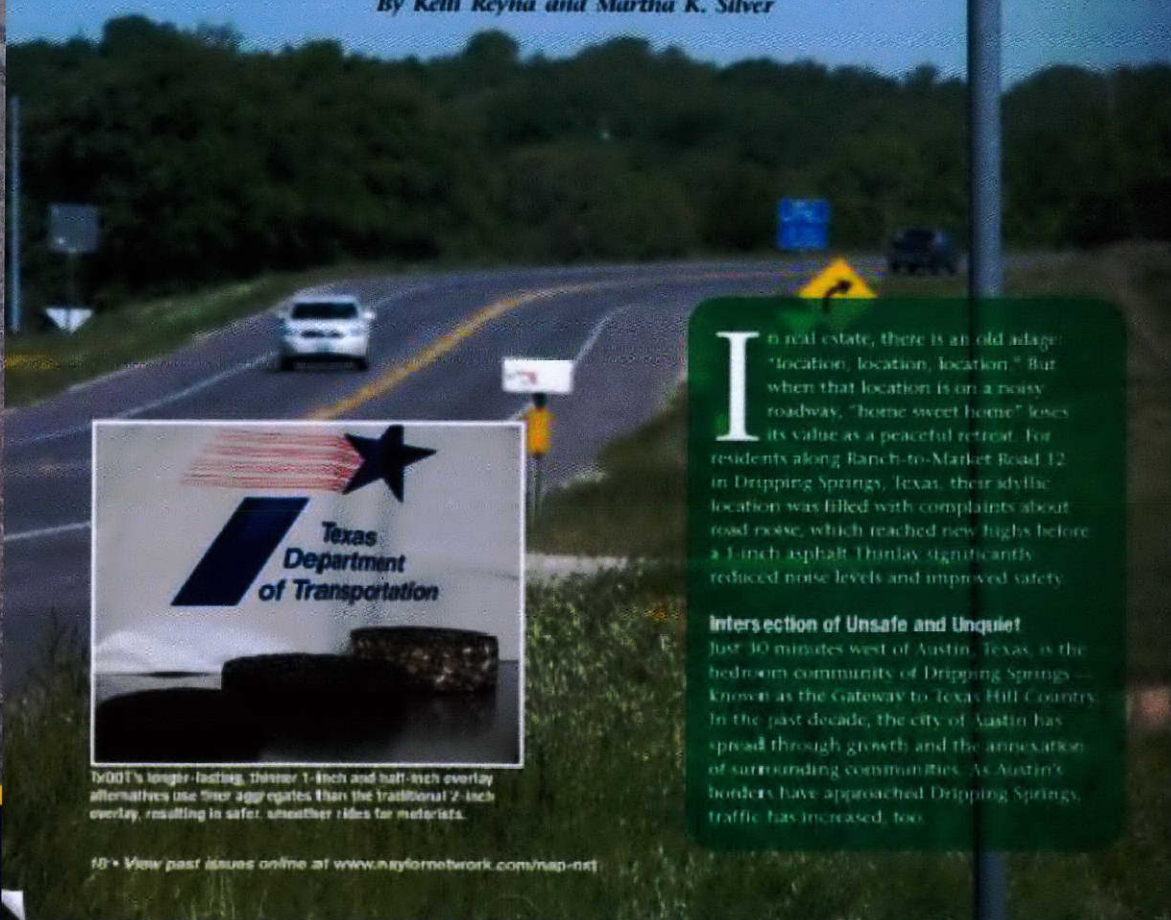

TxDOT's longer-lasting, thinner 1-inch and half-inch overlay alternatives use finer aggregates than the traditional 2-inch overlay, resulting in safer, smoother rides for motorists.

10 • View past issues online at [www.nyxflornetwork.com/nap-ntf](http://www.nyxflornetwork.com/nap-ntf)

In real estate, there is an old adage: "location, location, location." But when that location is on a noisy roadway, "home sweet home" loses its value as a peaceful retreat. For residents along Ranch-to-Market Road 12 in Dripping Springs, Texas, their idyllic location was filled with complaints about road noise, which reached new highs before a 1-inch asphalt Thinlay significantly reduced noise levels and improved safety.

#### Intersection of Unsafe and Unquiet

Just 30 minutes west of Austin, Texas, is the bedroom community of Dripping Springs — known as the Gateway to Texas Hill Country. In the past decade, the city of Austin has spread through growth and the annexation of surrounding communities. As Austin's borders have approached Dripping Springs, traffic has increased, too.



# Good Candidates for TOM-F Mixes

$\frac{1}{2}$  to  $\frac{3}{4}$  inch thick

- As a maintenance alternative for seal coats.
- Sections where an additional seal coat is not a good option.
- FM 2920 Tomball
  - April 2016





# Where ½-in TOM-F Overlays Used

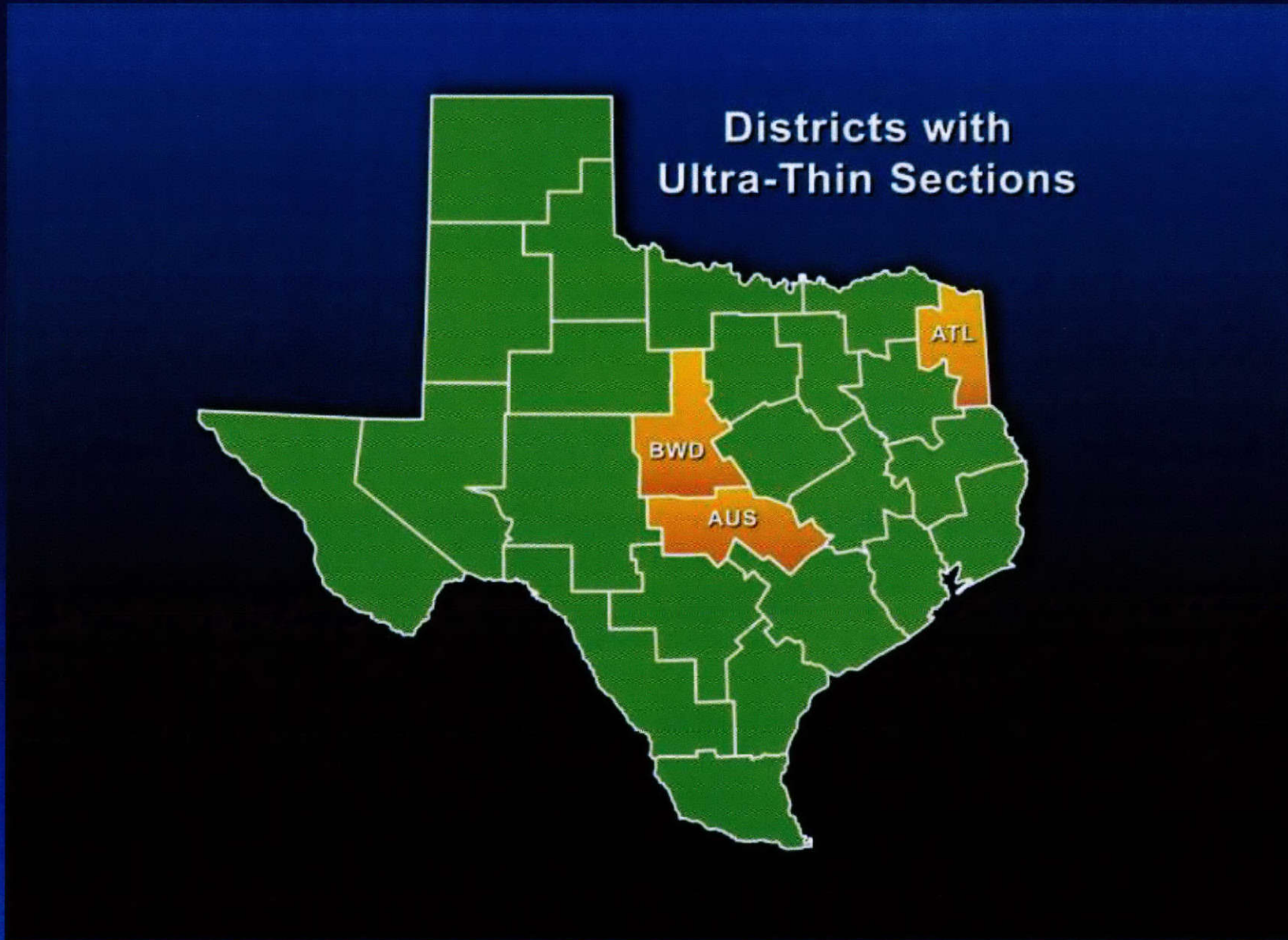



# Successful Uses of TOM-F Mixes





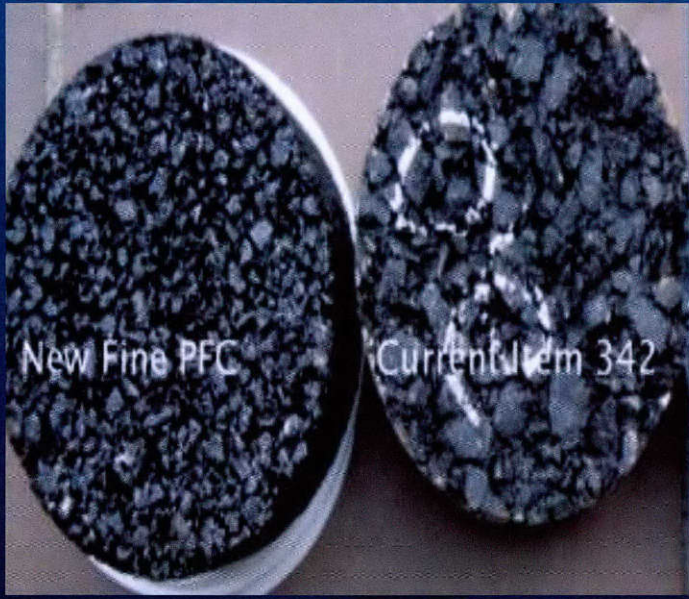

# Districts Using Fine PFC's

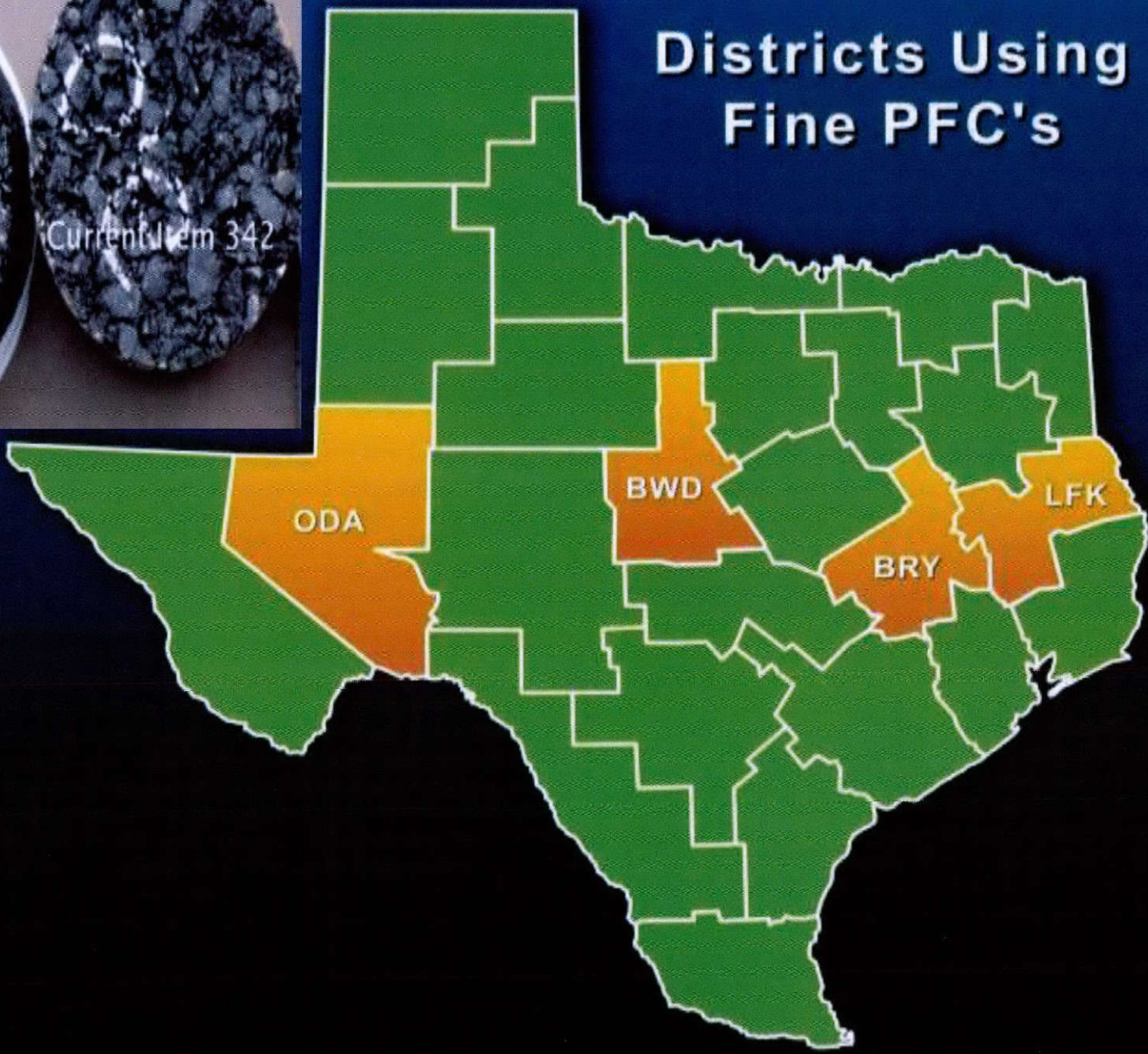



# July 2012 Full Scale Project Brownwood

- Full scale project US 183, Brownwood, to correct bleeding surface trt.
- 8.75 miles, 5000 tons, \$97/ton (Zack Burkett), CSJ 6231-69-001





Sept 2012

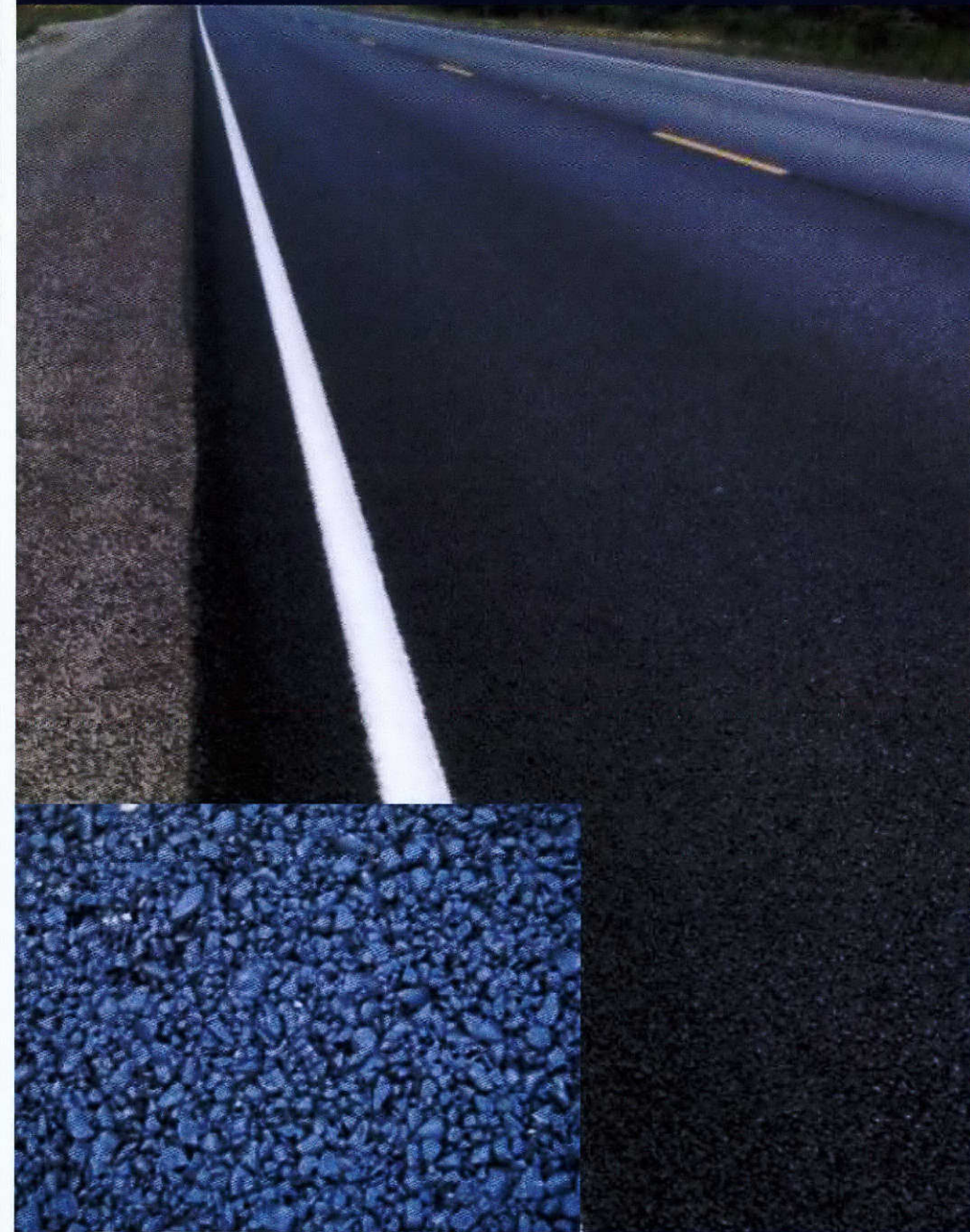

Cost ~ \$3.50 sq yd



# Typical Water Flow – 6 seconds



6-in diameter by 10-in high cylinder. Plumber's putty used to seal the edges of the pipe to pavement surface so water flows through the PFC.



Video showing typical traffic





# What's next for Fine PFC

Looking to place Fine PFC over deteriorated existing coarse PFC





# Site Selection

Transportation  
Institute



# Pavement Selection Considerations

- Use on structurally sound pavements – Pavements needing extensive base repair or requiring structural improvement should be avoided.
- Use on pavements requiring only restoration of the surface wearing course properties, such as skid resistance, elimination of surface distresses, improve ride quality, reduce noise.



# Good Candidates

- Shallow rutting < ½ in
- Top down cracking
- Longitudinal cracking
- Raveling
- Highly oxidized surface
- Polished surface – restore skid
- Acceptable ride quality (or level up also needed)
- Where cross slope correction not required
- Overlay not needed on shoulders
- CRCP Concrete pavements (Repair failures)
- JCP Concrete (Check joint movement)
- Bridge decks
- Where low noise surface is desired
- Both low and high volume traffic roadways



# Candidate Evaluation Process

- Is it a good Candidate for a TOM
  - Video Log (always)
  - GPR (Flexible) (if needed)
  - FWD (Flexible) (if needed)
  - TPAD (Concrete – especially Jointed) (if needed)
- If so:
  - what prep work is needed
    - Do I need a level up and/or chip seal?
    - Which areas need patching/milling
  - What problem areas are identified
    - Driveways
    - Intersections



# Surface Preparation (Austin District)

- Preparing and Repairing
  - Perform crack sealing and spot repair in highly distressed areas
  - Milled-in shoulder texturing and raised profile markings will reflect through – remove or fill
  - Mill and fill areas with fatigue cracking or shallow rutted areas with a fine dense-graded mix
    - Helps match existing surface
    - Promotes better ride with thin overlay
- Level-up
  - Should get a 25 to 35% improvement in IRI
  - If roughness > 120 in/mile, place level-up



# Video Log





# Roadway Video Logging



NcGrz	Star	End	Len	Comment
1	0+	0+3154	226	Outside lane to the go
2	0+	2+0+3793	860	
3	0+	3+0+4512	588	Center Lane
4	0+	5+0+1	64	274 Outside Lane
5	1+	1+141803	79	Outside Lane
6	1+	2+142988	245	Both Center & Outside
7	1+	3+143801	293	Center Lane
8	1+	3+144492	530	Outside Lane
9	1+	4+145225	410	Outside Lane
10	2+	1+2+1670	162	Outside Lane
11	2+	3+2+3239	130	Both Center and Outsi
12	2+	4+2+4971	103	Outside Lane
13	3+	1+3+1498	136	Center Lane
14	3+	2+3+2570	76	Outside Lane
15	3+	2+3+3270	294	Center Lane
16	4+	4+4+4394	115	Center Lane
17	5+	25+	372	97 Center Lane
18	5+	65+	936	100 CL
19	5+	526+	47	80 CL
20	5+	3+5+3943	150	Center Lane

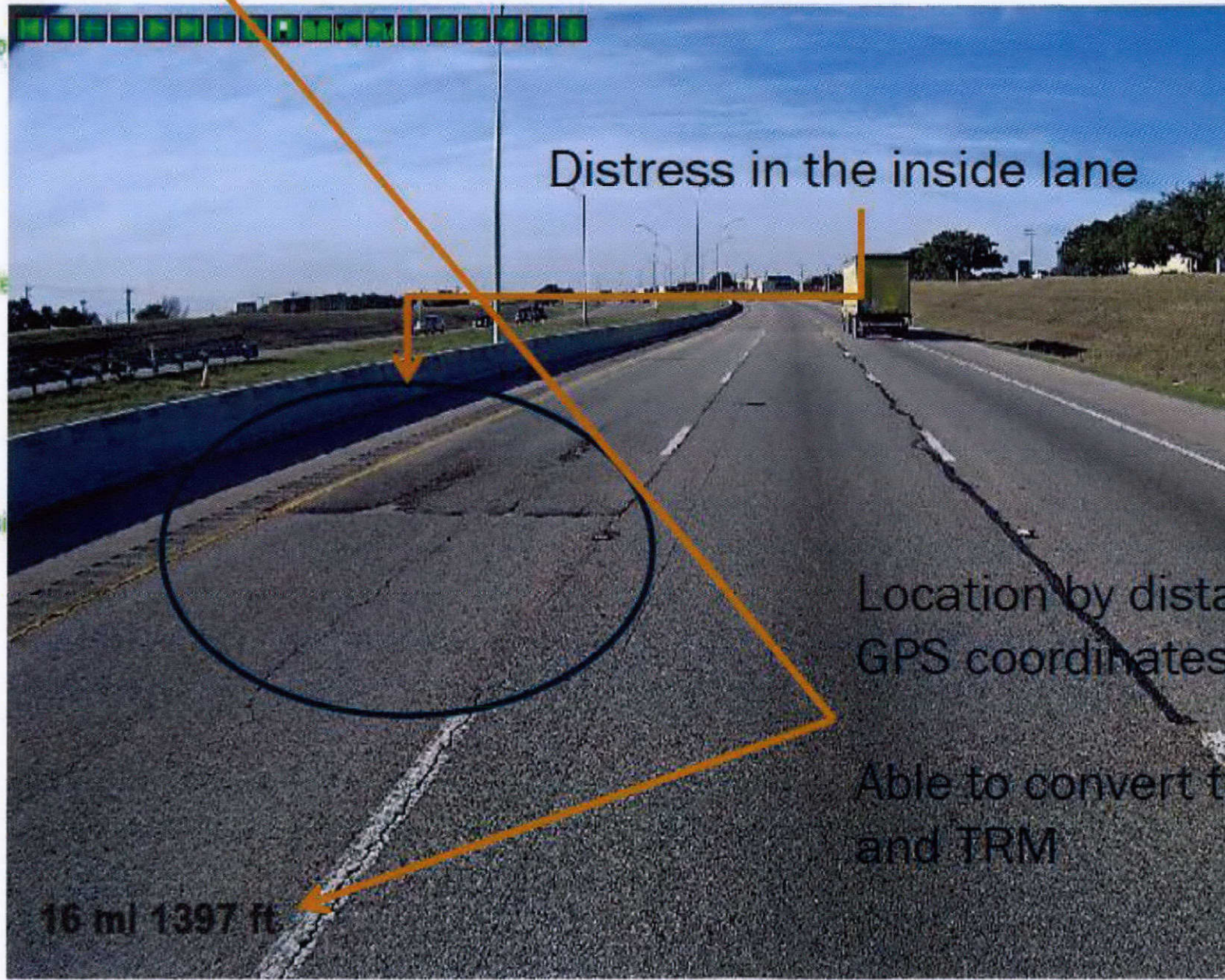





NcGrzStarEnd LenComment

	NcGrz	Star	End	Len	Comment
1	0+	10+3154	226	Outside lane to the g	
2	0+	2+0+3793	860		
3	0+	3+0+4512	588	Center Lane	
4	0+	5+1+	54	274 Outside Lane	
5	1+	1+1+1803	79	Outside Lane	
6	1+	2+1+2988	245	Both Center & Outsid	
7	1+	3+1+3801	293	Center Lane	
8	1+	3+1+4492	530	Outside Lane	
9	1+	4+1+5225	410	Outside Lane	
10	2+	1+2+1670	162	Outside Lane	
11	2+	3+2+3239	130	Both Center and Out	
12	2+	4+2+4971	103	Outside Lane	
13	3+	1+3+1498	136	Center Lane	
14	3+	2+3+2570	76	Outside Lane	
15	3+	2+3+3270	294	Center Lane	
16	4+	4+4+4394	115	Center Lane	
17	5+	25+	372	97 Center Lane	
18	5+	85+	936	100 CL	
19	5+	526+	47	80 CL	
20	5+	3+5+3943	150	Center Lane	

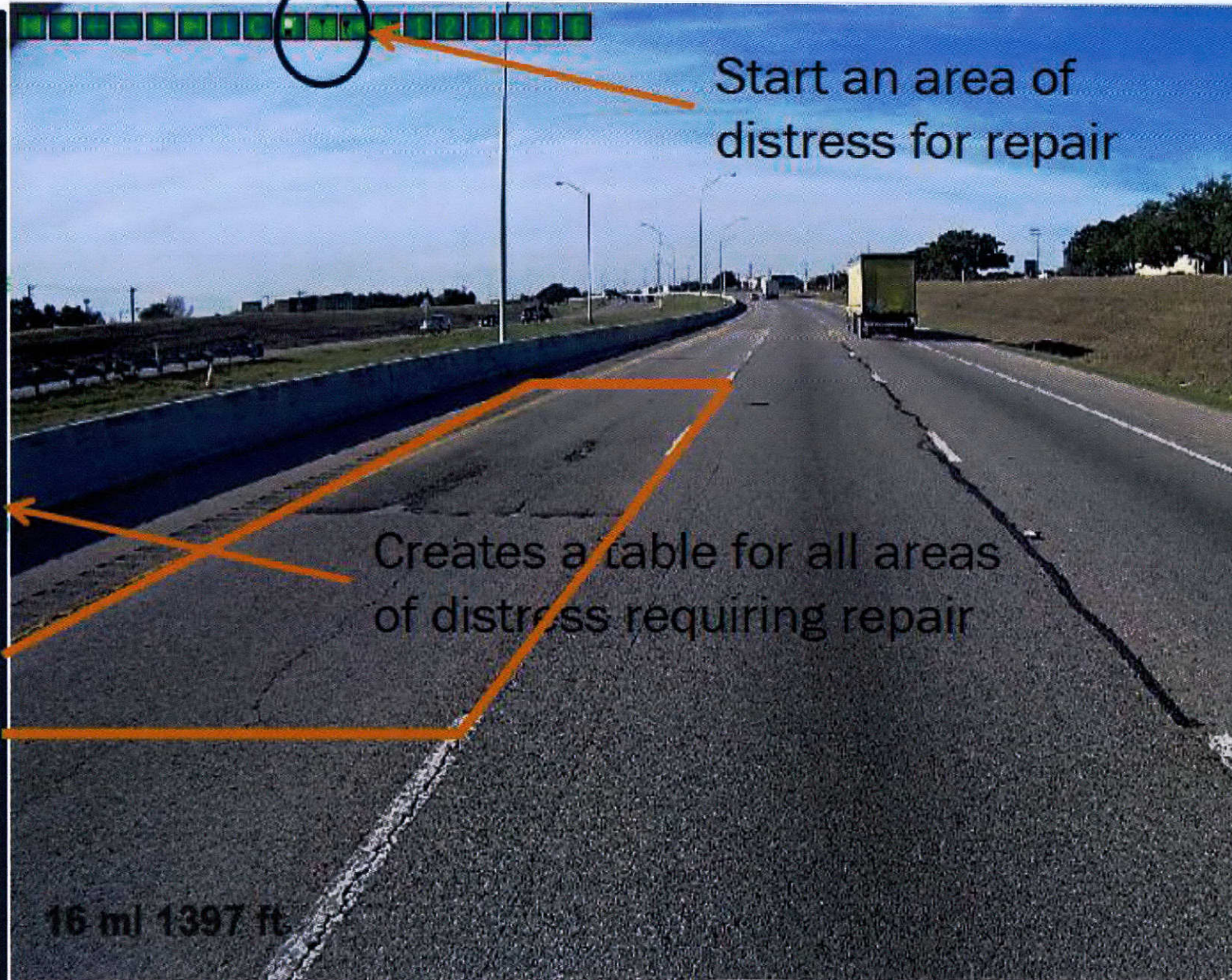

Maps the repair area





# Pavement Selection Consideration for TOMs

## Does the Projects have any near surface defects

- Ground Penetrating Radar (GPR): Determine existing pavement thickness, including HMA and base course thickness, near surface defects (stripping)





# Pavement Selection Consideration for TOM

- Is the project structurally OK
  - Falling Weight Deflectometer (Flexible): or TPAD Testing (Concrete)  
Pavement response to determine overall pavement capacity and subgrade support

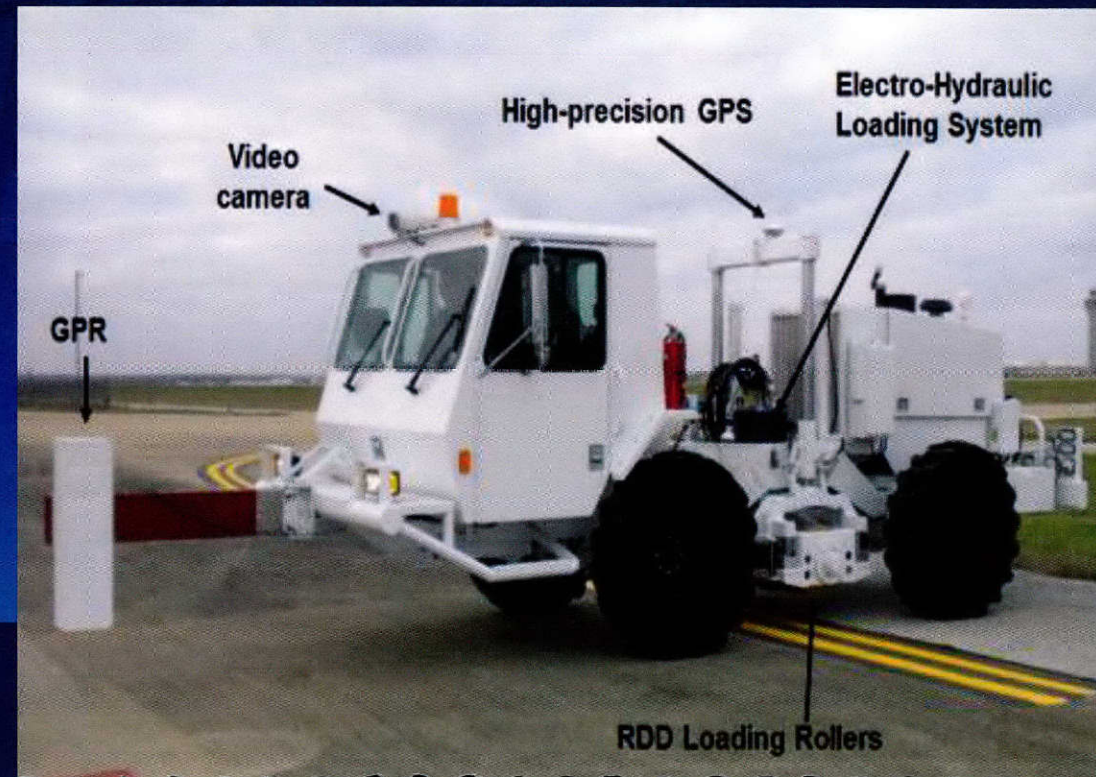



**US 59 Frontage Road BW 8 to Bissonnet to South Gessner**



**Case 1**

**Is this JCP a candidate for a Thin Overlay**



**Yes good for thin Overlay  
 90% of project looked like this**

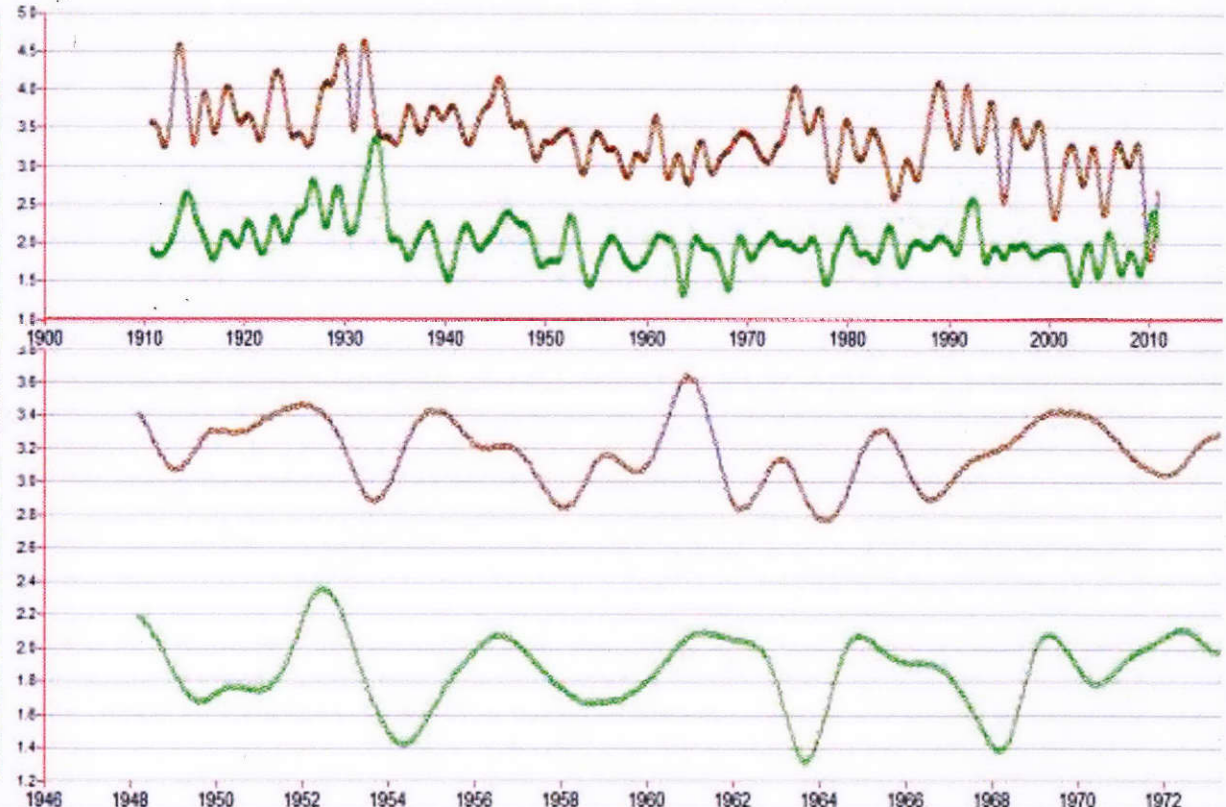
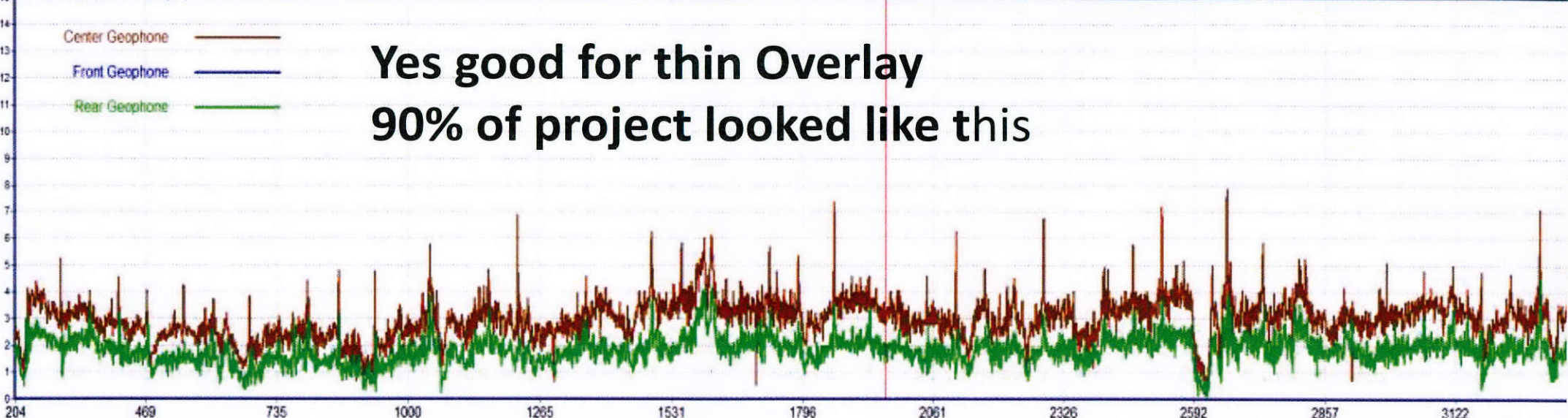



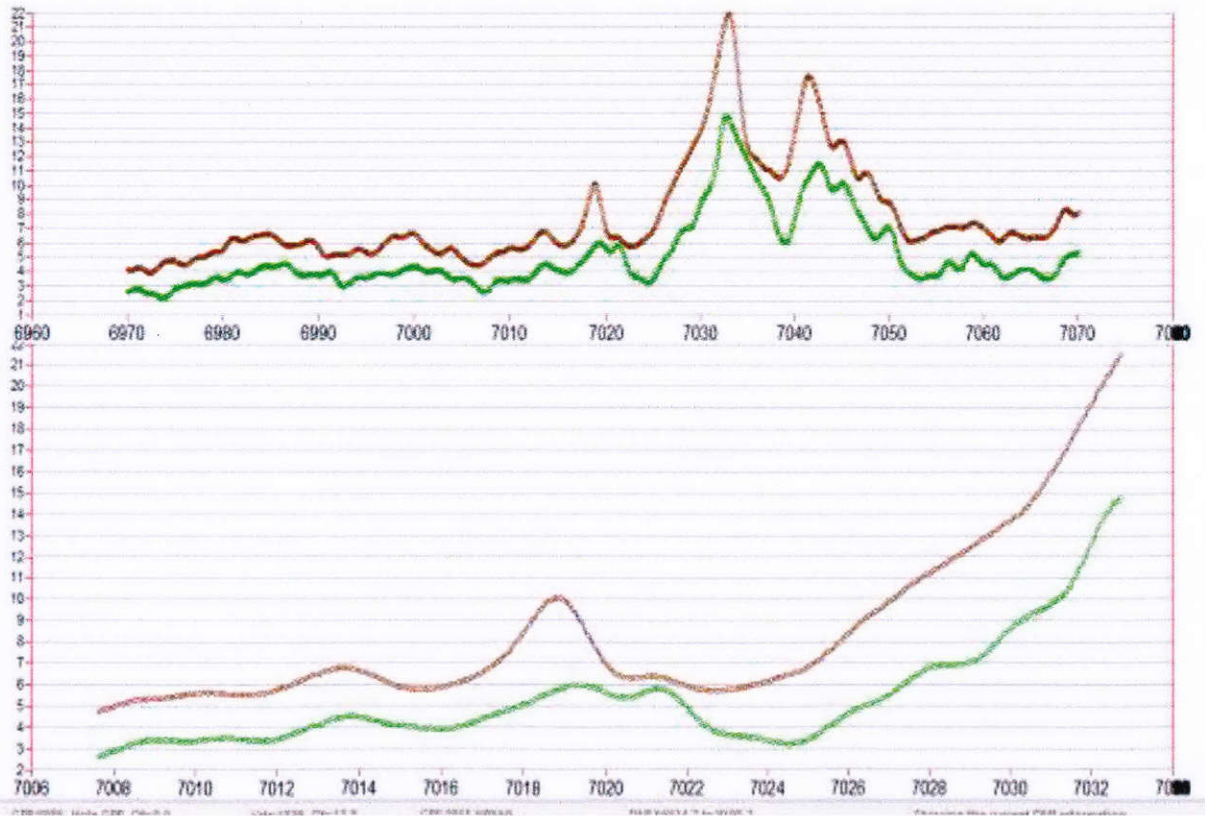
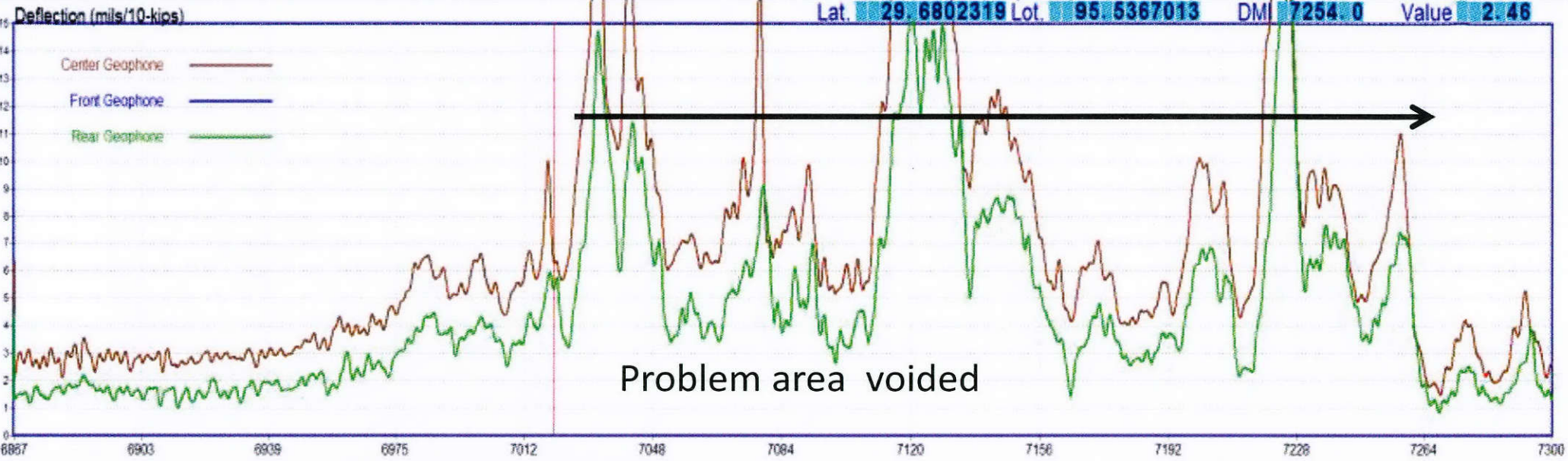



# Structurally Deficient – Not Good Candidates









# Case Study on FM 1960

- Is it a Good candidate
- What areas of Concern

Texas A&M  
Transportation  
Institute



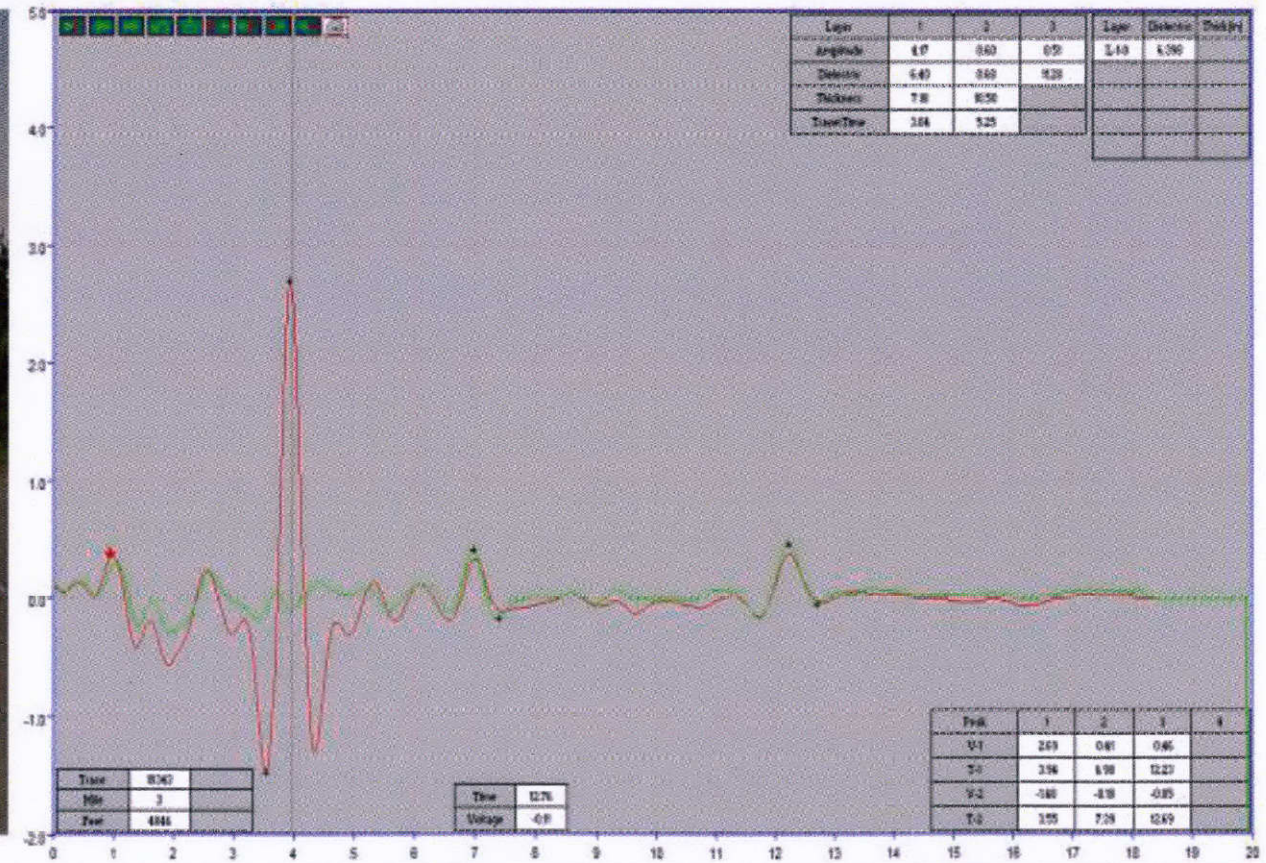
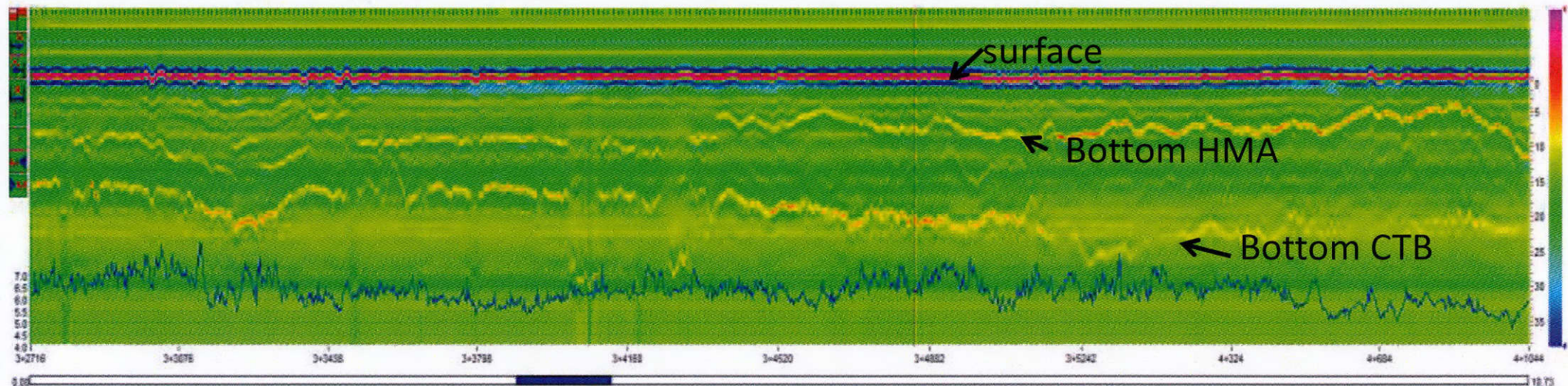



# Transition from wide shoulder also start of poor surface mix about 1.25 miles east of US 59





Poor Surface Mix raveling (thermal segregation) at least 60% of section





# Typical narrow shoulder section

## Full edge paving Mill 1 inch





Typical Wide shoulder section  
Possible only Pave 18 inches inside  
shoulder and taper mix





# Few localized bumps must be milled flat





Few areas with wide cracks

Patch any failures or locations with loose material





# Many major intersections



3 mi 2966 ft



# Lots of traffic loops etc





# Case Study 2

## IH 45

TRANSPORTATION  
INSTITUTE



# Trapped Water under outside lane ?



Gulf Fwy

© 2014 Google  
© 2014 Google

Google earth

of transportation



# Drill Dry Hole what is this (Moisture/Uretek/grout)

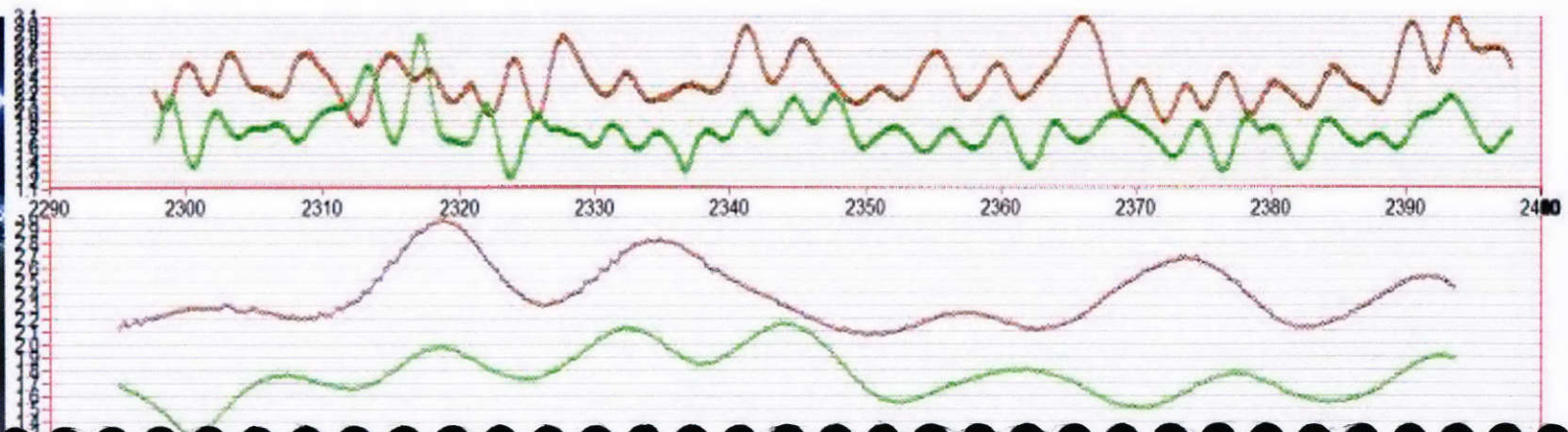
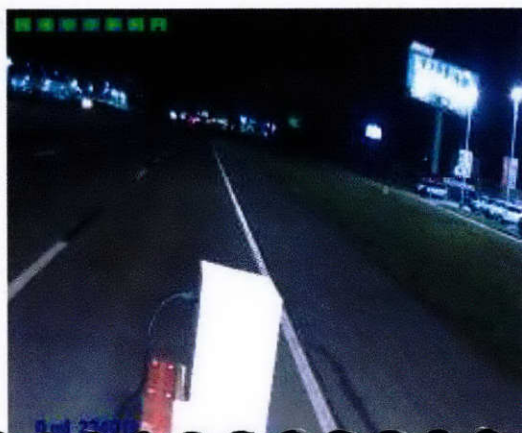
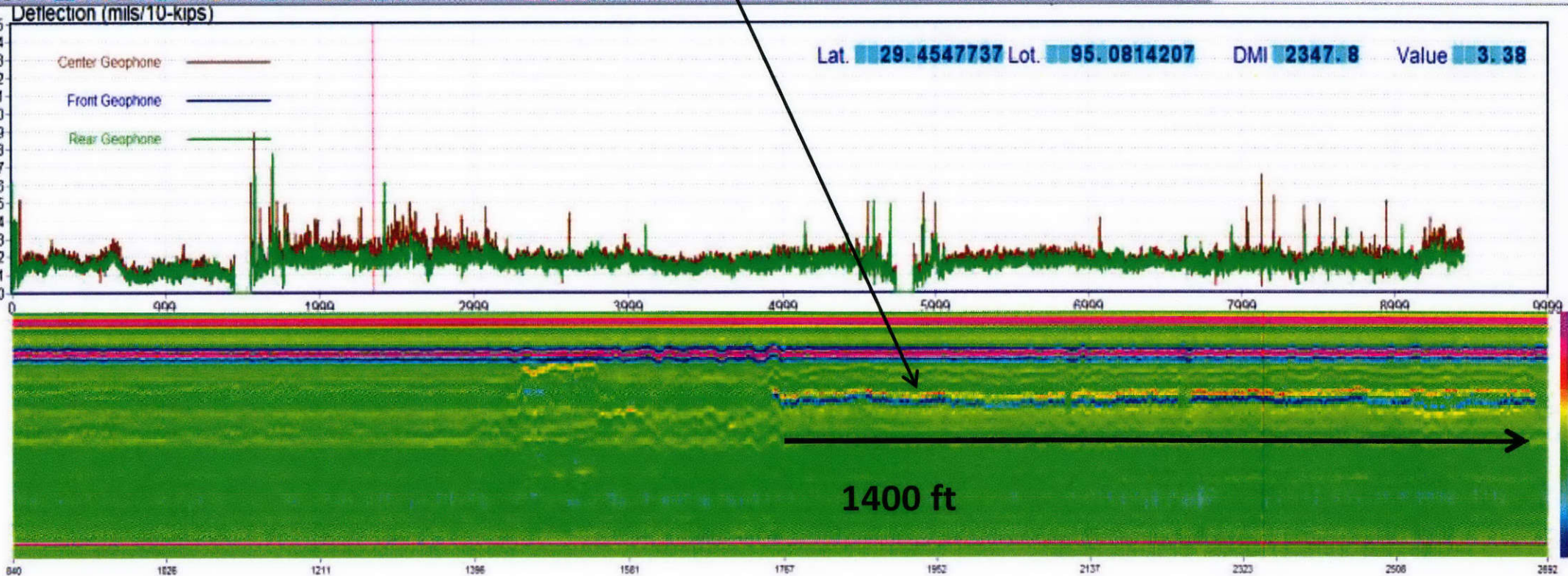



Is this patch stable



© 2014 Google  
© 2014 Google

Google



# NB problem patch

Raw data file has 7147750 point and 26591 group. Current road segment is:3

File Edit View Help

FCR ok bad Data View 1 Data View 2 R < R > Other UT Data View 3 Data View 4

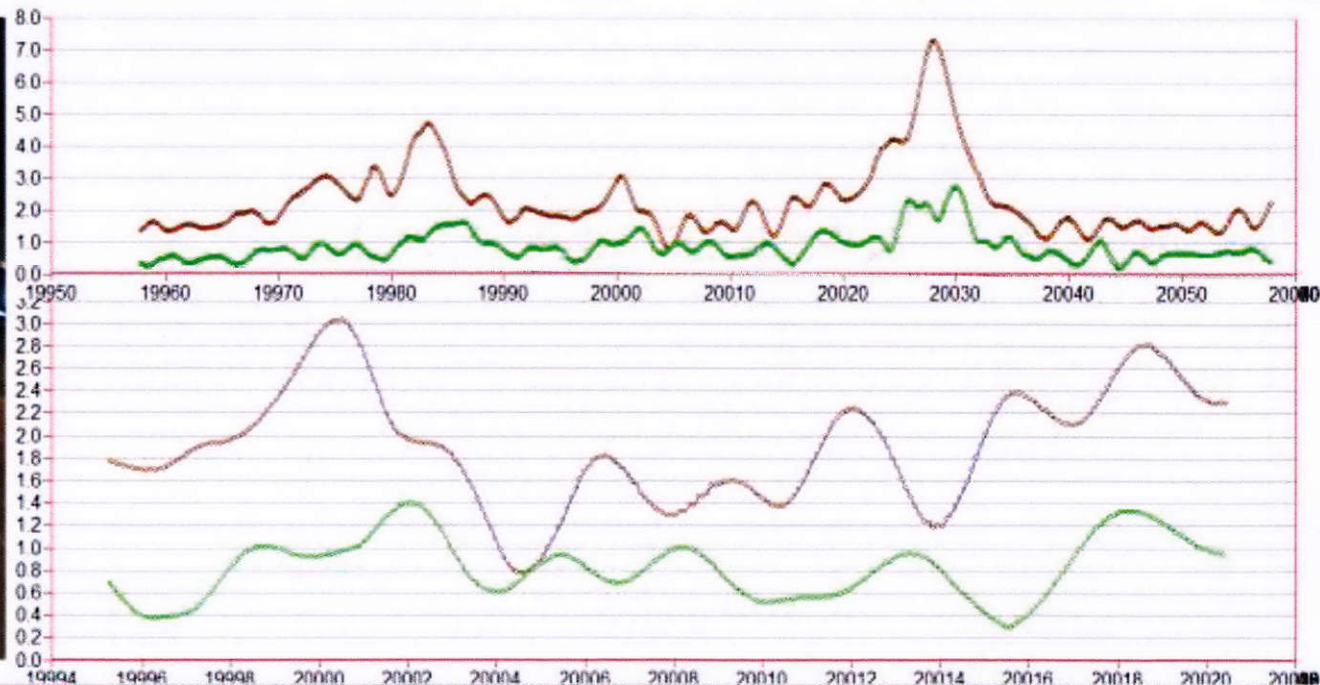
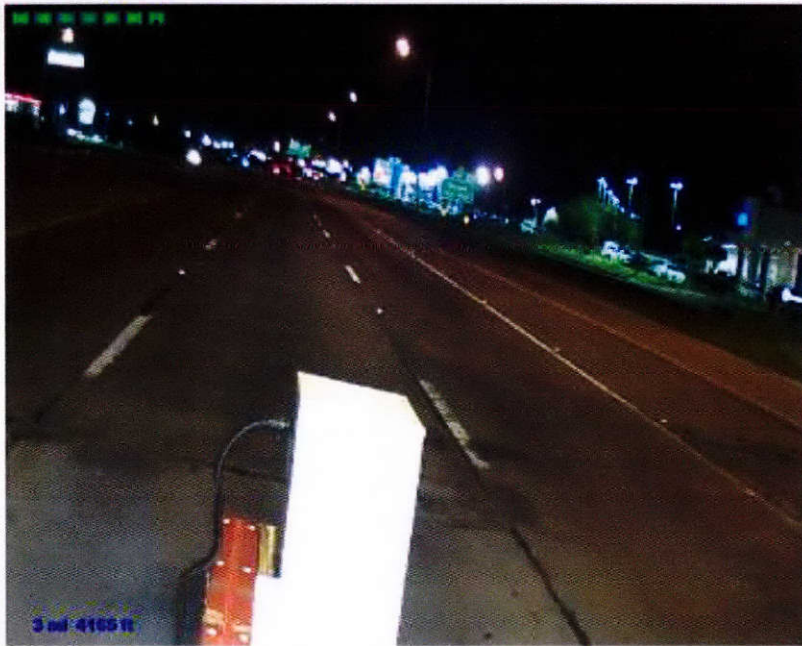
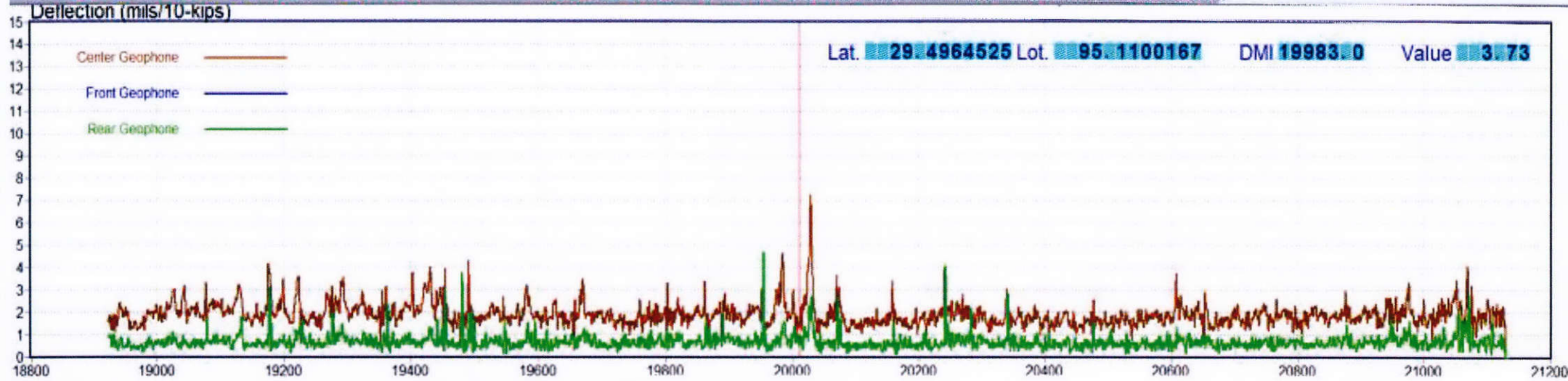



End of Part I of Class

TRANSPORTATION  
Institute



# Part II of Class

## Project Inspection

- Surface prep
- HMA bonding
- Compaction
- Acceptance



# Mixture Types

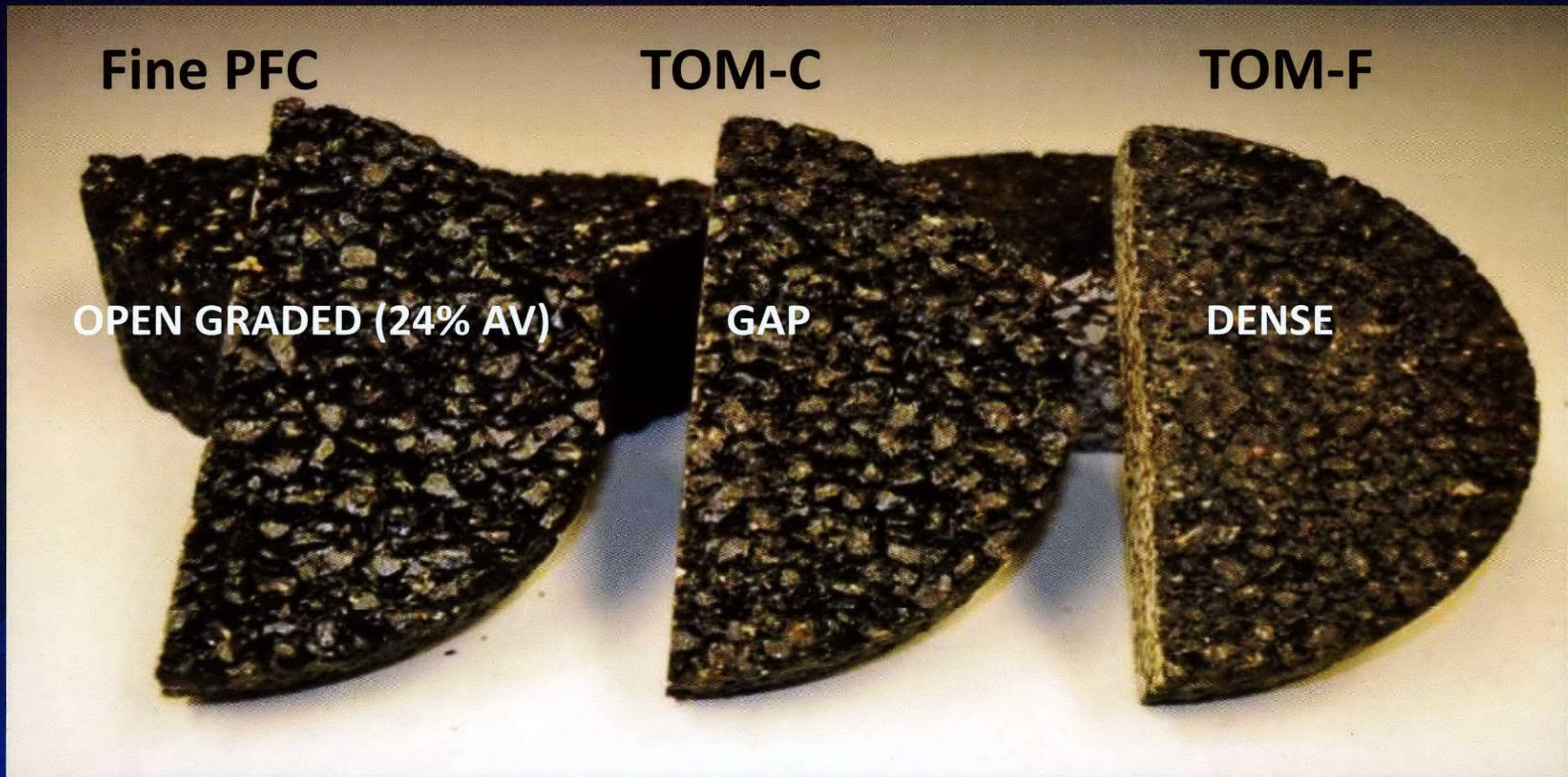

- 30% Cost savings over traditional mixes - lifts of 1 inch or less
- Pass Rutting (HWTT) and Cracking (OT) performance tests
- Mandate PG 76-22 SAC A Grade 5 Rock + Screenings







NcGrzStarEnd LenComment

NcGrz	Star	End	Len	Comment
1	0+	10+3154	226	Outside lane to the g
2	0+2'	0+3793	860	
3	0+3'	0+4512	588	Center Lane
4	0+5'	0+61+	64	274 Outside Lane
5	1+1'	1+1803	79	Outside Lane
6	1+2'	1+2988	245	Both Center & Outsid
7	1+3'	1+3801	293	Center Lane
8	1+3'	1+4492	530	Outside Lane
9	1+4'	1+5225	410	Outside Lane
10	2+1'	2+1670	162	Outside Lane
11	2+3'	2+3239	130	Both Center and Out
12	2+4'	2+4971	163	Outside Lane
13	3+1'	3+1498	136	Center Lane
14	3+2'	3+2570	76	Outside Lane
15	3+2'	3+3270	294	Center Lane
16	4+4'	4+4394	115	Center Lane
17	5+	5+25+	372	97 Center Lane
18	5+	5+936	100	CL
19	5+	5+526+	47	80 CL
20	5+3'	5+3943	150	Center Lane

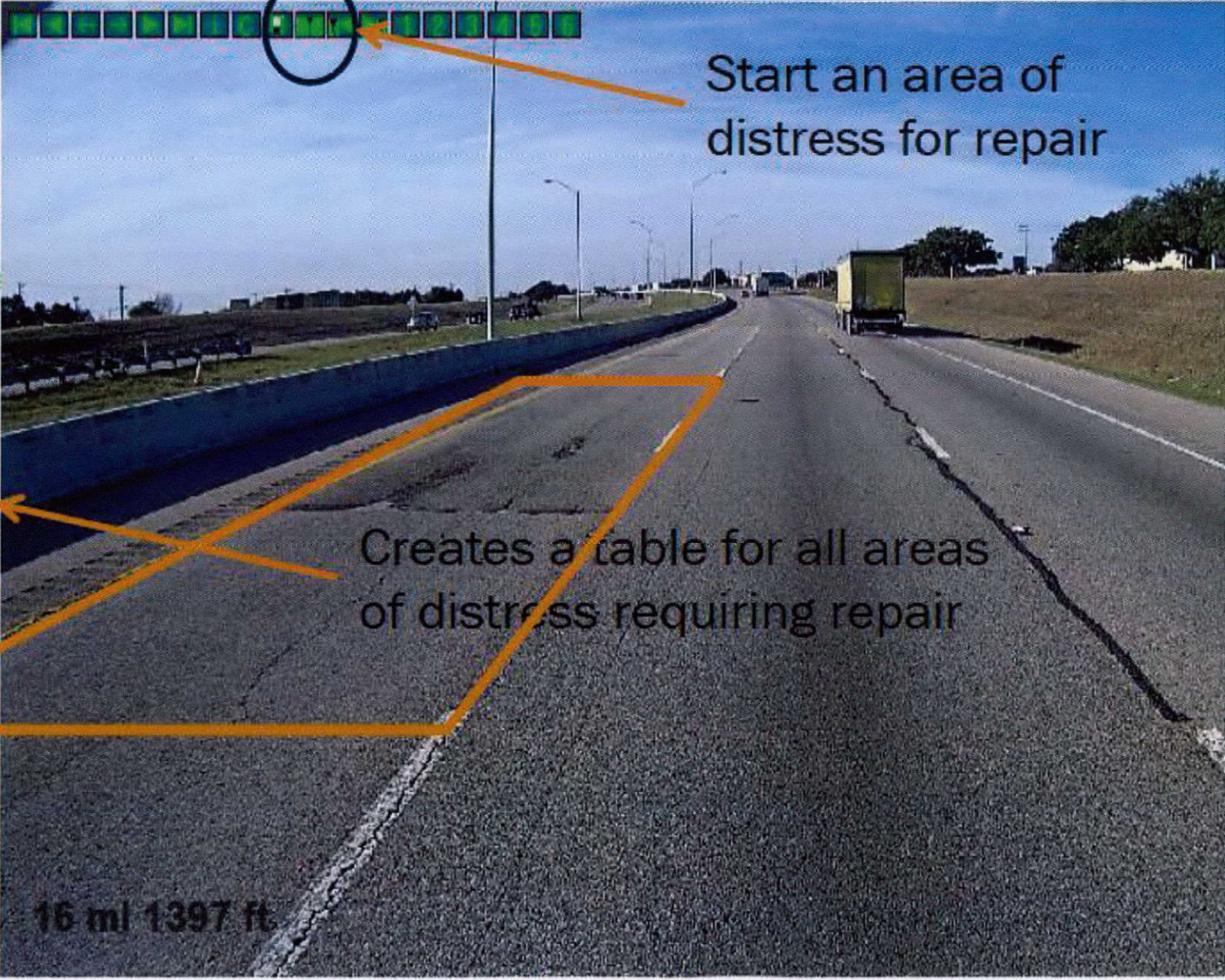

Start an area of distress for repair

Creates a table for all areas of distress requiring repair

Maps the repair area

16 mi 1397 ft



# Houston's Plan Notes 1 of 2

## **Item 347: Thin Overlay Mixture (TOM)**

Provide an asphalt binder PG 76-22. Substitution of the PG binder is not allowed.

Place mixture at the compacted lift thickness of one (1) inch.

Provide 100% SAC "A" aggregate. Blending of coarse aggregate is not allowed. A maximum of 25% SAC "B" screening material can be used.

Do not use RAP and RAS in the mixture.

A Pave-IR system or Thermal camera system is mandatory for this project. The contractor must demonstrate that the mixture is being placed with no severe thermal segregation.

Provide a mix which lasts more than 500 cycles in the Overlay Tester.

For breakdown rolling use two steel-wheel rollers working in tandem without excessive breakage of the aggregate and provide a smooth surface and uniform texture, keeping the rollers as close as possible to the lay-down machine. Do not use pneumatic-tire rollers. Use a steel wheel as the finish roller.



# Houston's Plan Notes 2 of 2

**Water flow measurements as per Tx Method 246 are mandatory for setting rolling patterns. The contractor must report the selected patterns to TxDOT and show that it meets the water flow requirements**

**[ftp://ftp.dot.state.tx.us/pub/txdot-info/cst/TMS/200-F\\_series/pdfs/bit246.pdf](ftp://ftp.dot.state.tx.us/pub/txdot-info/cst/TMS/200-F_series/pdfs/bit246.pdf)**

**Avoid excessive compaction where water flows of greater than 10 minutes are not allowed, the final surface must have acceptable macro-texture.**

**The tack coat must be a hot applied trackless tack.**

**All construction joints must be placed under the paint stripes between the lanes. (No joints near wheel paths)**

**Performance test will be required on all mix design and trial batch samples, for each mold 6 samples at optimum asphalt content at 7% air voids content each will be 6 inches in diameter by 2.4 inches thick (Hamburg sized samples). The samples are to be sent to the Texas Transportation Institute (TTI) for Hamburg Wheel Test and Overlay test. This work is subsidiary to the various bid items.**



# Typical Water Flow – 6 seconds for PFC



6-in diameter by 10-in high cylinder. Plumber's putty used to seal the edges of the pipe to pavement surface so water flows through the PFC.



# Keys to Successful Construction

- Preparation
  - Spot Repair: Isolated failures
  - Level-Up: Areas with greater than 120 in/mile
  - Milling: Recommend micromilling for smaller peak to valley

TRANSPORTATION  
Institute



# Surface Preparation

- Preparing and Repairing
  - Perform crack sealing and spot repair in highly distressed areas
  - Milled-in shoulder texturing and raised profile markings will reflect through – remove or fill
  - Mill and fill areas with fatigue cracking or shallow rutted areas with a fine dense-graded mix
    - Helps match existing surface
    - Promotes better ride with thin overlay
- Level-up
  - Should get a 25 to 35% improvement in IRI
  - If roughness > 120 in/mile, place level-up



# Milling

- Milling recommended if
  - Pavement highly oxidized/stiff
  - Cross-slope corrections needed
  - Minor to moderate ride issues
  - Extensive thermal or top-down cracking (>40 percent by area)
  - Extensive recent crack seal
  - Micromilling recommended if milling required - creates a finer finish with small peak-to-valley depths to prevent compaction and ride issues



# Plant Inspection/Role of Inspector





# Plant Inspection

- Proportioning aggregates
- Metering Asphalt
- Setting Feeding Unit
- Pugmill Mixer
- Mixing Time
- Checks on Asphalt Content



# Sampling and Testing

- Purpose of tests
- Sampling Schedule
- Testing Trial Batch

4.4.2.1.13. **Trial Batch Testing.** Test the trial batch to ensure the mixture produced using the proposed JMF1 meets the mixture requirements in Table 8. Ensure the trial batch mixture is also in compliance with the Hamburg Wheel test, Overlay test, and drain-down requirements listed in Table 7. Use a Department-approved laboratory to perform the Hamburg Wheel test on the trial batch mixture or request that the Department perform the Hamburg Wheel test. Obtain and provide approximately 50 lb. of trial batch mixture in sealed containers, boxes, or bags labeled with the CSJ, mixture type, lot, and subplot number for the Overlay test. The Engineer will be allowed 10 working days to provide the Contractor with Hamburg Wheel test and Overlay test results on the trial batch. Provide the Engineer with a copy of the trial batch test results.



# Production

- Keep Plant clean to prevent clumps = Pop outs
- Load Temperatures = 315 – 330 F

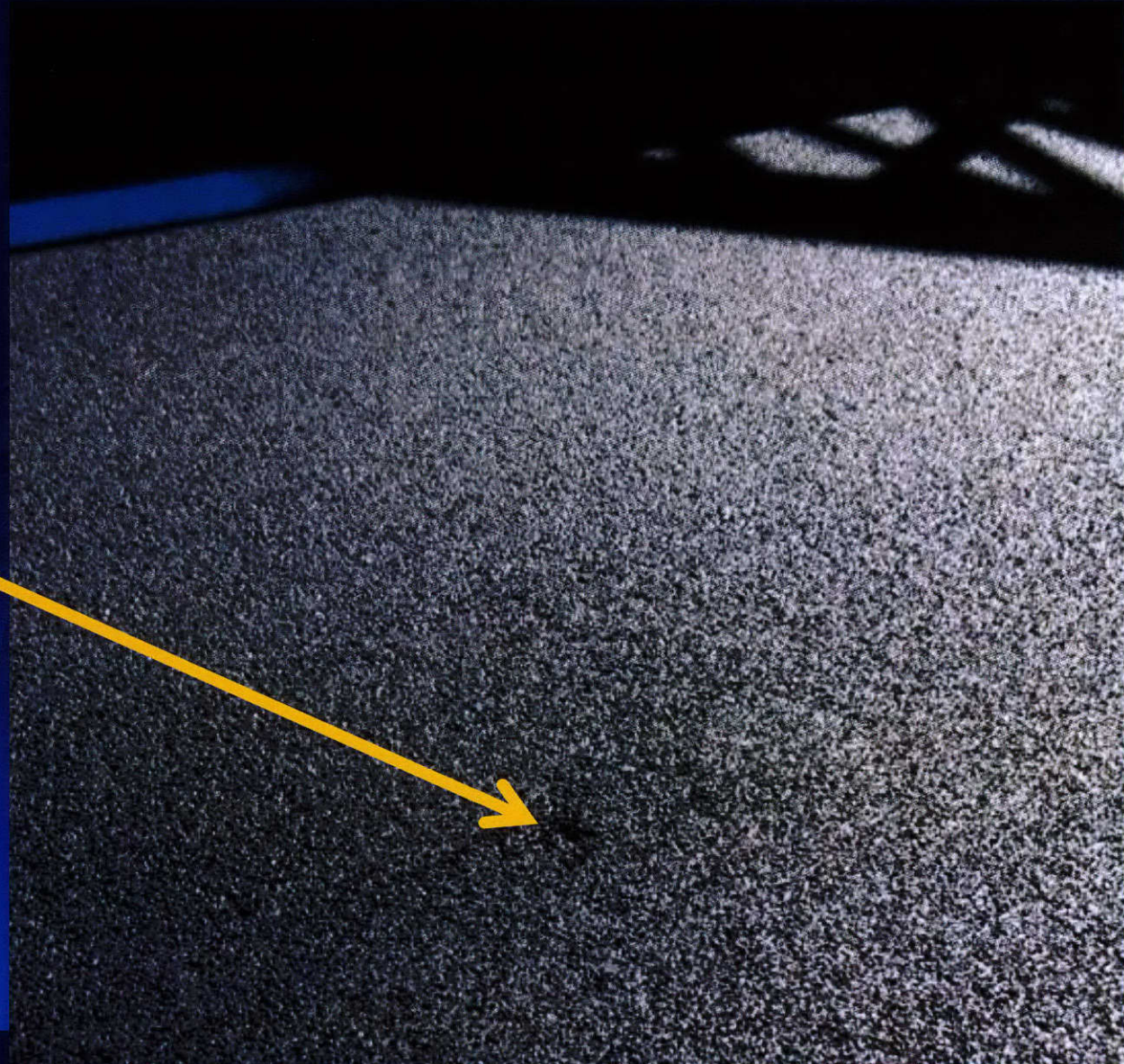



# Tack Coats/Bonding/Underseals

Transportation  
Institute



# Seal and Bond

- Bond is critical for thin overlays
- TOM-C is somewhat open graded, so a good seal is important to prevent moisture infiltration.

4.7.2. **Tack Coat.** Clean the surface before placing the tack coat. The Engineer will set the rate between 0.04 and 0.10 gal. of residual asphalt per square yard of surface area. Apply a uniform tack coat at the specified rate

**Trackless Tack Strongly Recommended**



# Tack Coats

- Bonding
  - On existing HMA, apply non-tracking tack, chip seal, or use spray paver.
  - Apply non-tracking tacks at 0.03 to 0.06 gal/sy







23.9	19.0	14.8	10.7	9.6	9.3	25.6	15.1	21	29 grams
.056	.044	.035	.025	.022	.021	.060	.036	.05	.068 gal/sq yard



# Problems with the spray bar





# Check Nozzle Angles

CORRECT

All Nozzles at the Same Angle



INCORRECT

Some Nozzles at Different Angles





# Poor Nozzle Alignment

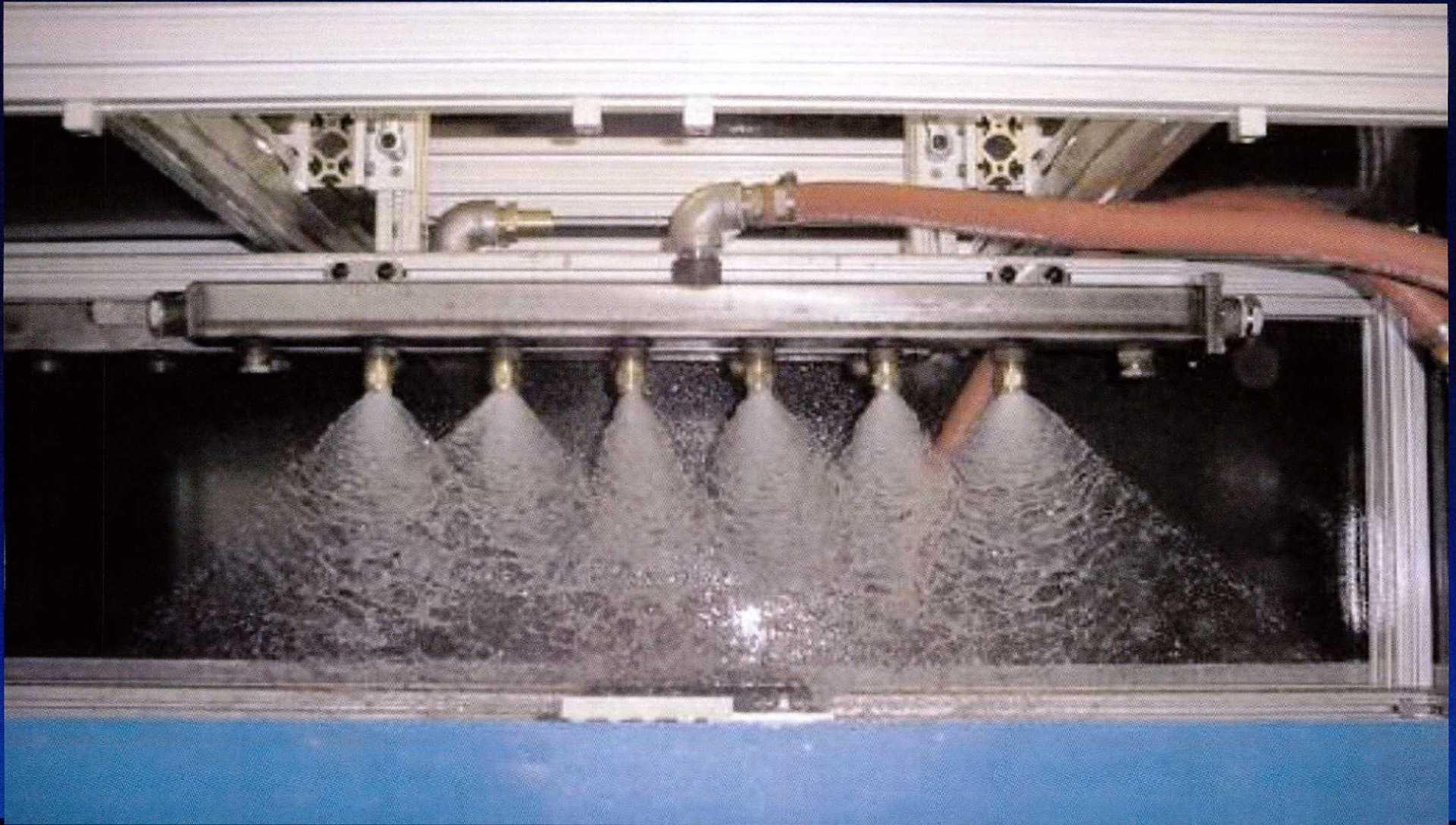



# Proper Nozzle Alignment





# Check Nozzle Angles

**YES**

Same Angle

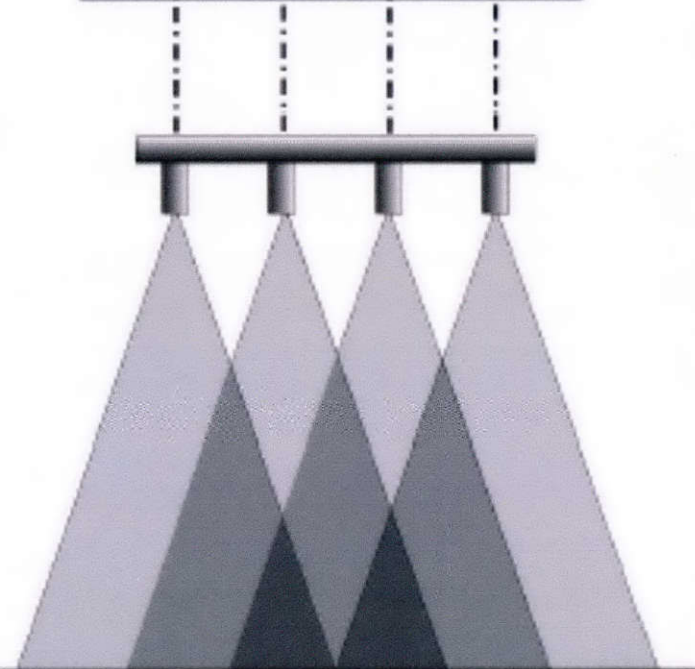

Fans are the same width

**NO**

Different Angles

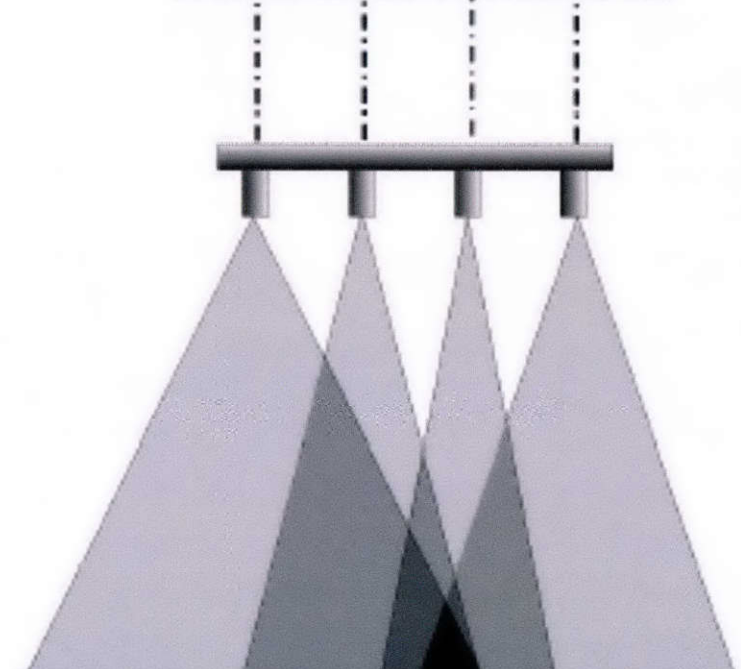

Fans are different widths



# Real problems with heavy shot rates under Roadtec loads





# Underseals

- Underseals (chip seals/interlayers)
  - Only if significant unsealed cracks
  - If milling will expose underlying cracking
  - If overlaying newly widened sections
  - Use polymer modified binder in chip seal
  - Design chip seal with smaller aggregate (Grade 4 or 5)
  - Use proper chip seal construction practices







# Seal Coat and Bonding Best Practices

- Light aggregate rates when using underseals
- Prefer heavy tacks - prevent bonding issues in areas with too much aggregate
- Windrow and transfer material with a shuttle buggy in the adjacent lane
- VERY clean surface to promote good bonding
- Take cores to verify bond and thickness



# Roadtec feeding paver and also dropping stuff









# Direct Tensile Bond Test ASTM C-1583

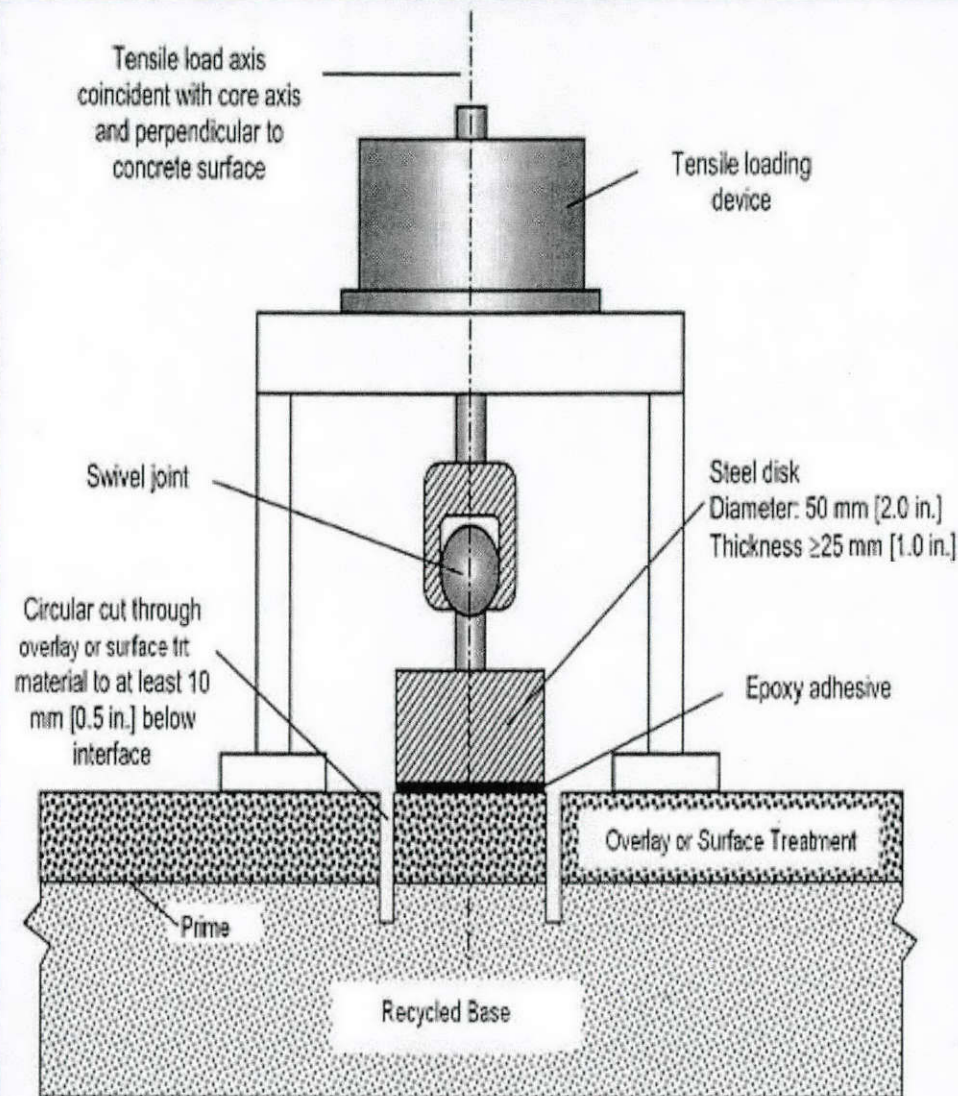



# Sequence in the Bond strength test

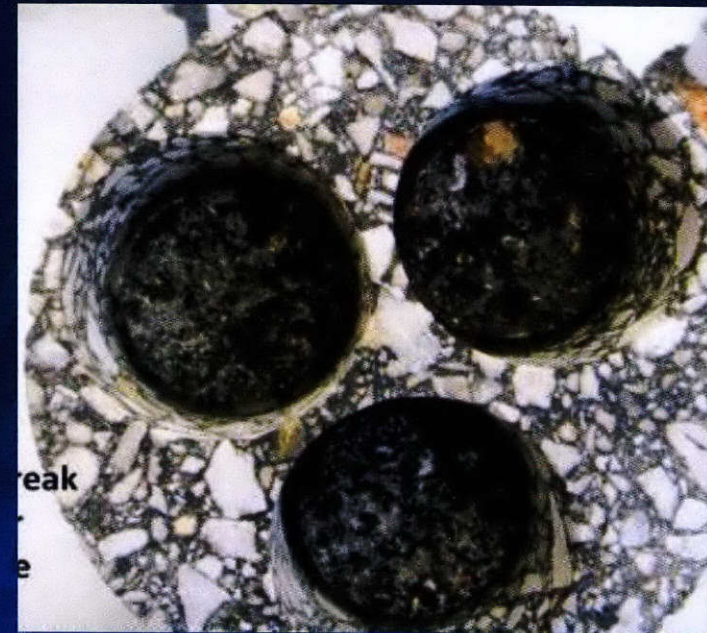



Thin Overlay did not Bond to Traffic  
Loops....mill them out!!





# Placement and Compaction

TRANSPORTATION  
Institute



# Good Paving Practices

- Laydown Machine Operation
- Rollers
- Materials Transver vs traditional pick up
- Pave IR



# Mixture Placement

## Best Practice

- Use a shuttle buggy to maintain temperature
- Use insulated truck and trapped
- WMA additive helped as a compaction aid in cooler temperatures
- District may require WMA for hauls greater than 50 miles





# Temperature Requirements

- Item 347 allows the following:
  - Roadway temperature of 32F when using thermal imaging system **NOT RECOMMENDED!!!**
  - **Use the following Plan Note:**
  - When not using thermal imaging system, surface temperature should be min 60F



# Thermal Profile – SR 220



- Good thermal uniformity
- $\Delta T$  between 18 and 28 °F
- Paver idle 7% of time due to paver stops
- AVG speed 26.9 ft/min

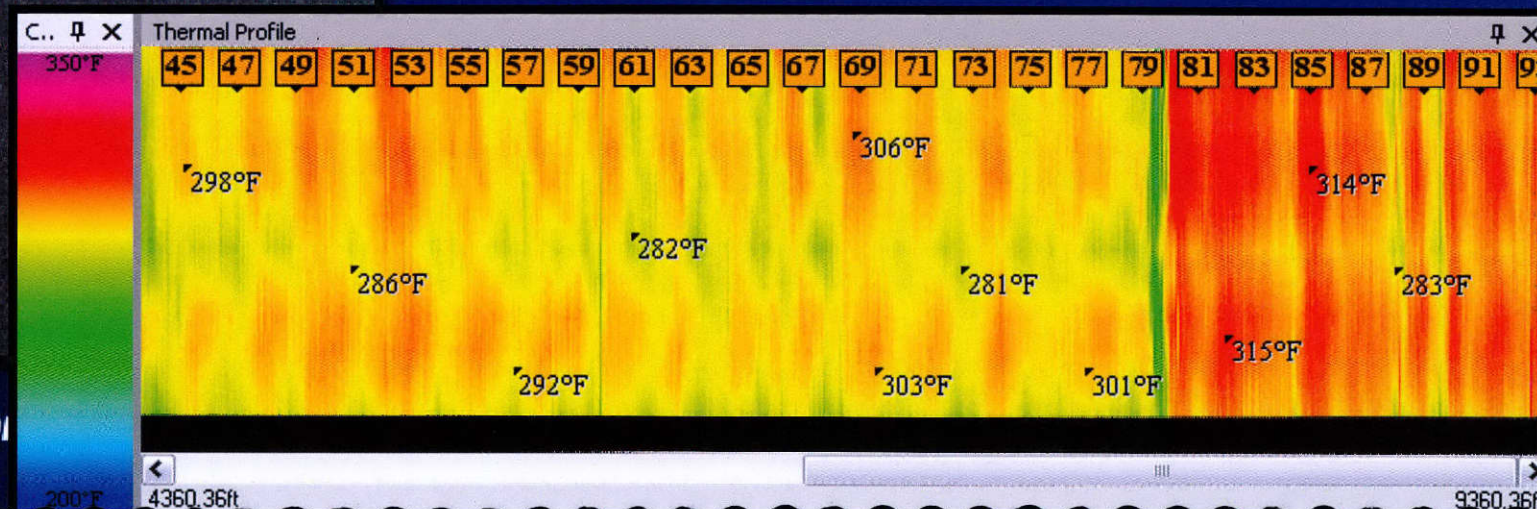



View and  
annotate  
profile

Histograms

Project metrics

- Paver speed
- Idle time
- Total duration

# Post-Process view and report from IR Profile

**Thermal Profile Results Summary**

Number of Profiles	Moderate 25.0°F < differential <= 50.0°F		Severe differential > 50.0°F	
	Number	Percent	Number	Percent
127	18	14	2	2

ID: Demonstration Page: 1

---

**Summary of Locations with Thermal Segregation**

Profile Nr	Beginning Location		Ending Location		Max Temp	Min Temp	Temperature Differential
	Station	GPS in °	Station	GPS in °			
1	325.47	97.62704 W, 30.77293 N	326.97	97.62713 W, 30.77251 N	327.4	273.7	53.6
2	326.97	97.62713 W, 30.77261 N	328.47	97.62727 W, 30.77212 N	311.2	269.1	42.1

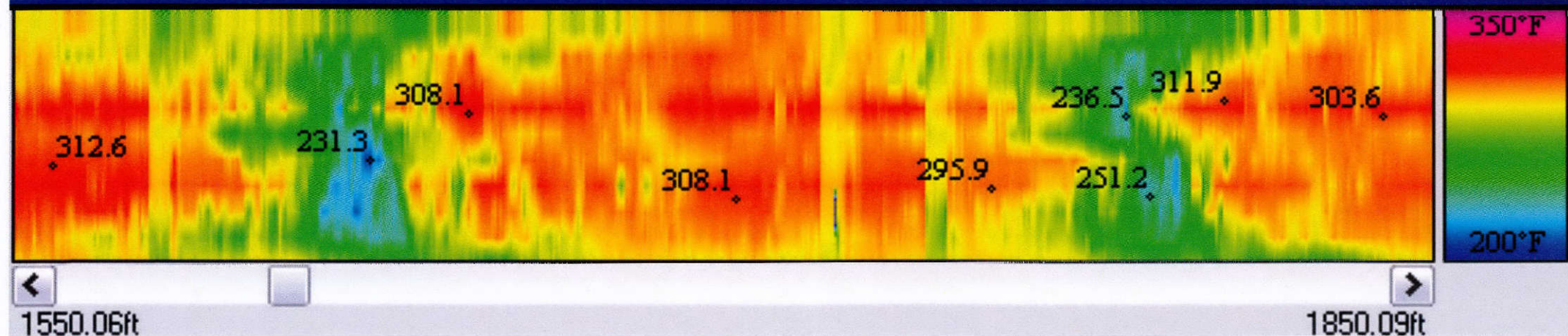



# Measured temperature drops on thin lifts; Need 2 rollers working in echelon

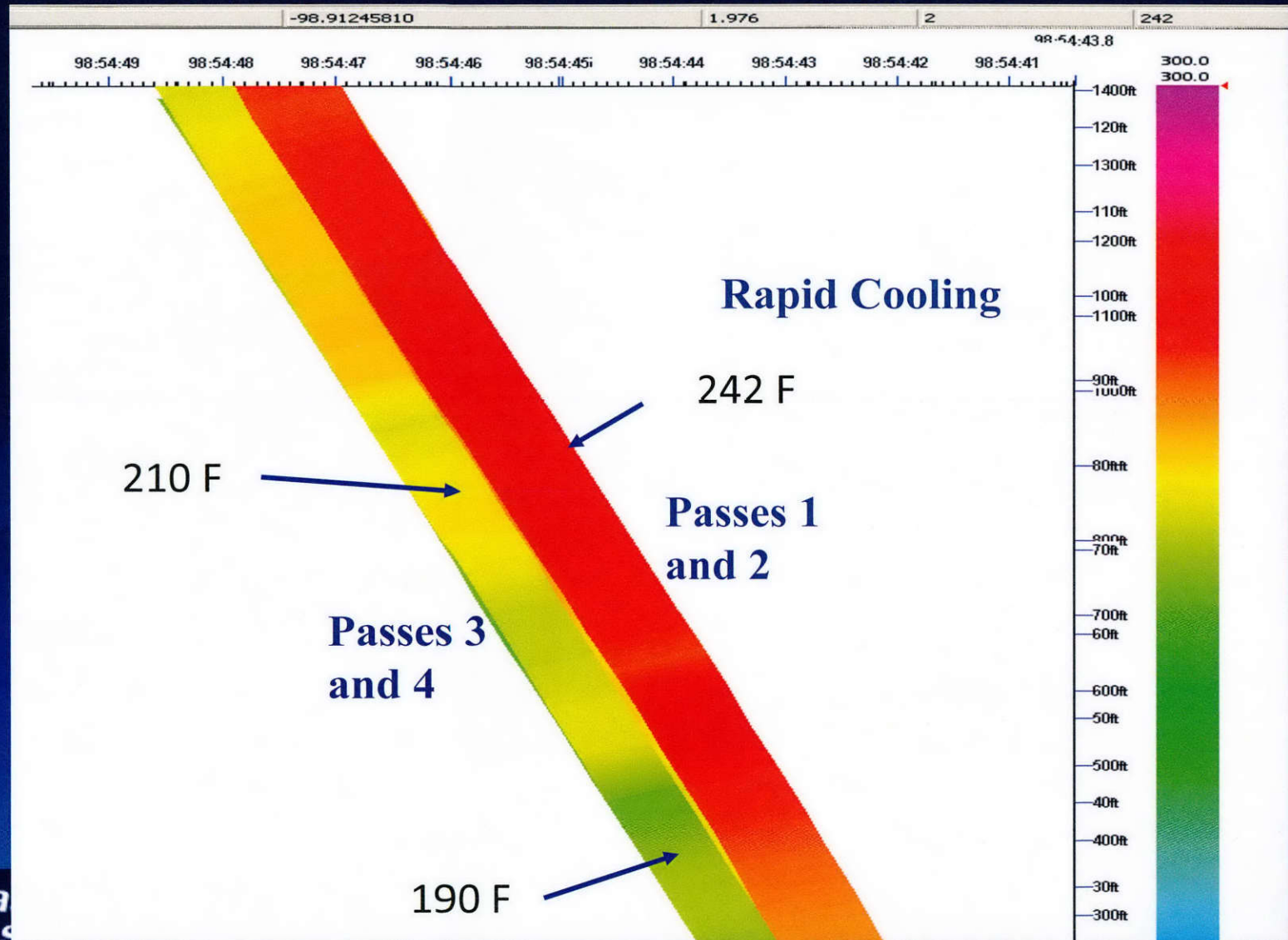



# Placement and Compaction

## – Limit hand work

- Irregularities show up more dramatically in thin overlays

## – No pneumatics.... Closes surface

- Macrotexture for skid resistance is diminished
- Cools too quick to take out impressions

## – Rollers should be right behind the paver Harsh mix and cools quickly



# Compaction





# Compaction

- Recommend dual rollers in tandem
- TOM-C (3 passes – each pass is one vibratory/one static)
- TOM-F mixes 3-5 static passes
- Fine PFC, 1 to 3 static passes
- Need adequate release agents (mix very sticky)



# SH 73 Beaumont's first TOM-C

- Rolling Crown
- Over-compaction

Texas A&M  
Transportation  
Institute



# Day 1 Problems Streaking + No water flow

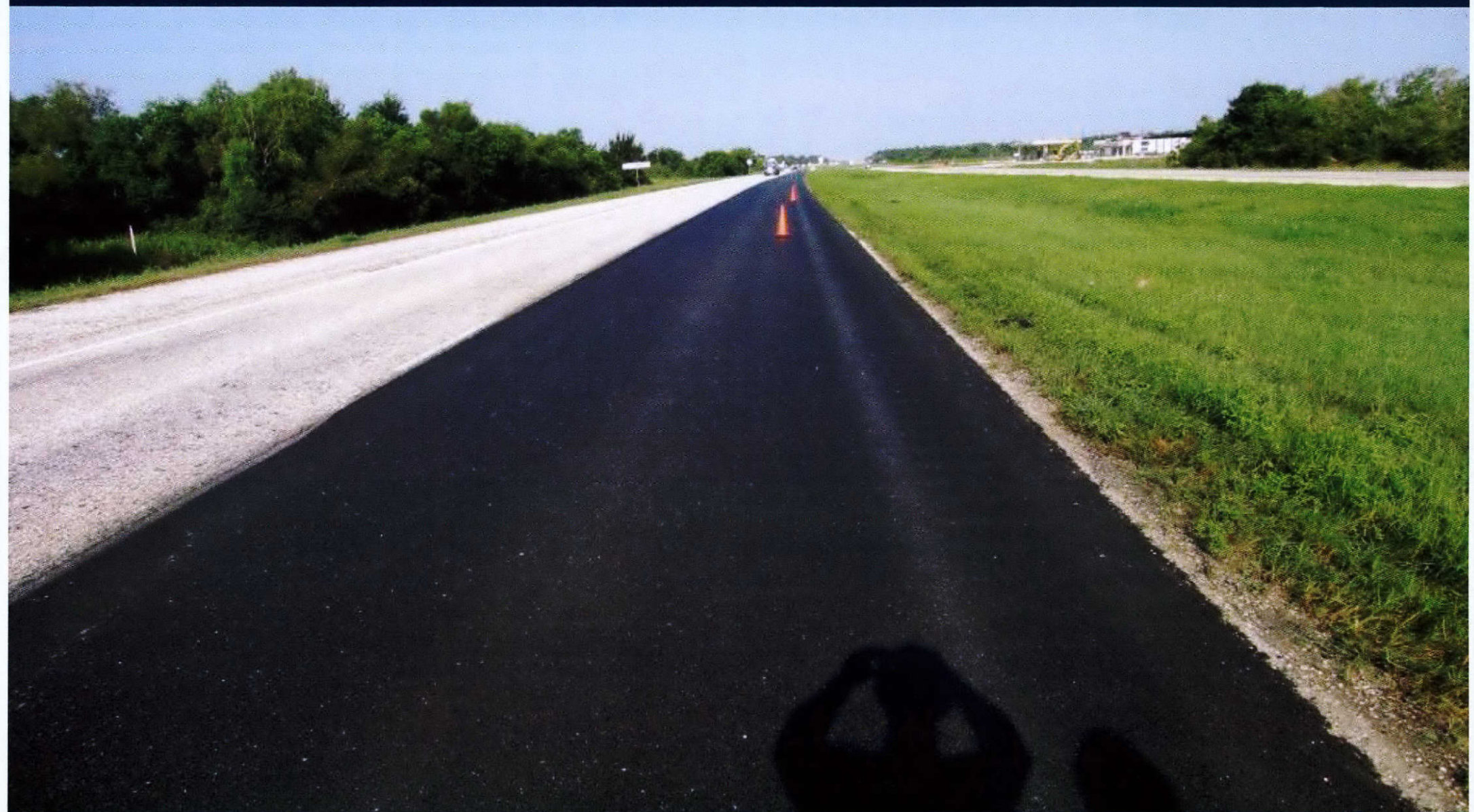



Day 1 > 15 mins





# Paving Operation

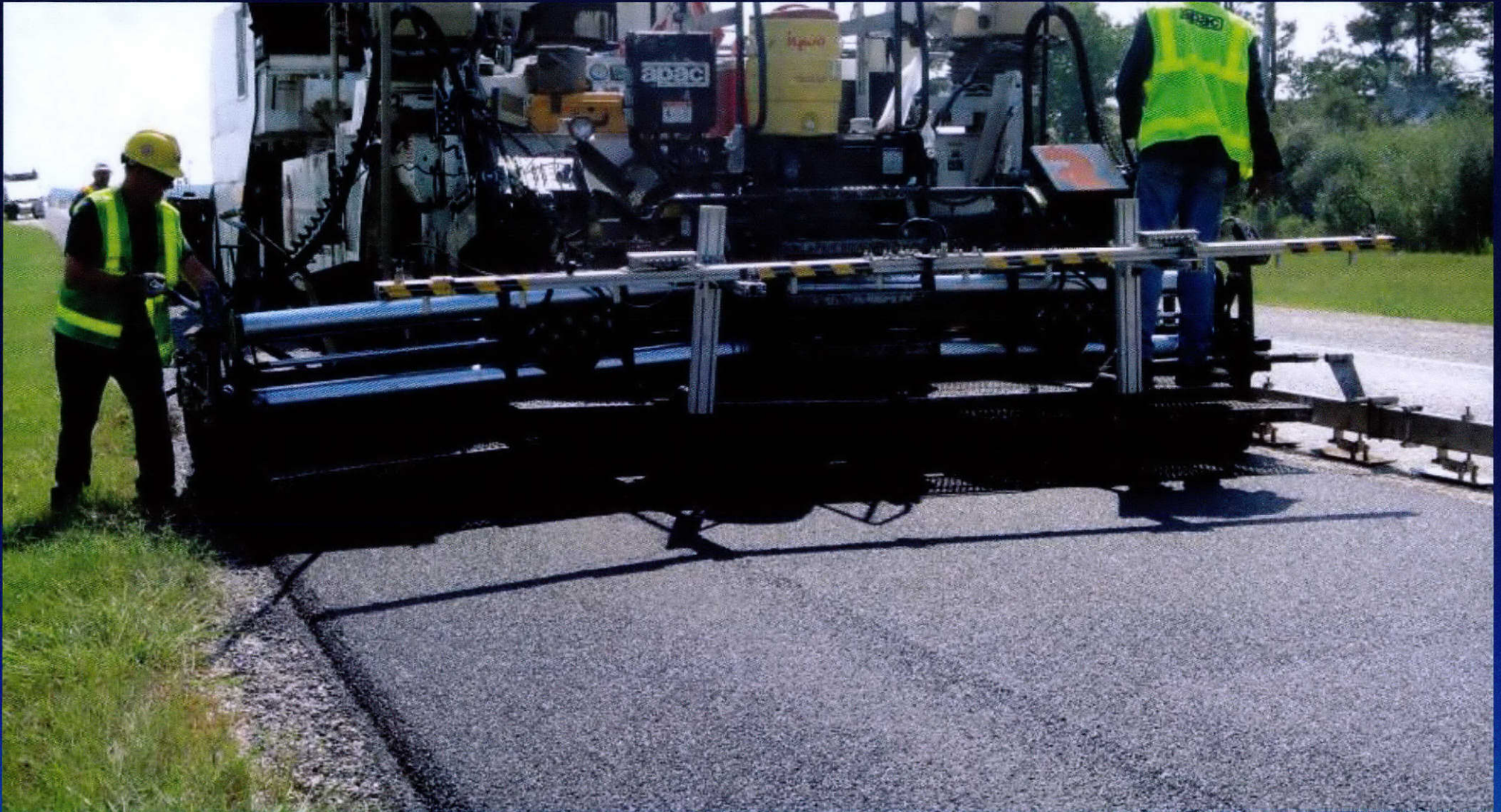



# Rolling Crown was an Issue





# Adjustments to Rolling pattern

- Two rollers side by side in main lanes
- Smaller roller only doing edge
- Change to vib up static back
- Water flow 4 mins
- Texture good





# Acceptance Testing

TRANSPORTATION  
Institute



# Acceptance Testing

- Acceptance in the Field
  - Water Flow Test (Tex 246-F)
    - (Flow rate > 2 minutes) for TOMs
    - < 20 secs for PFC





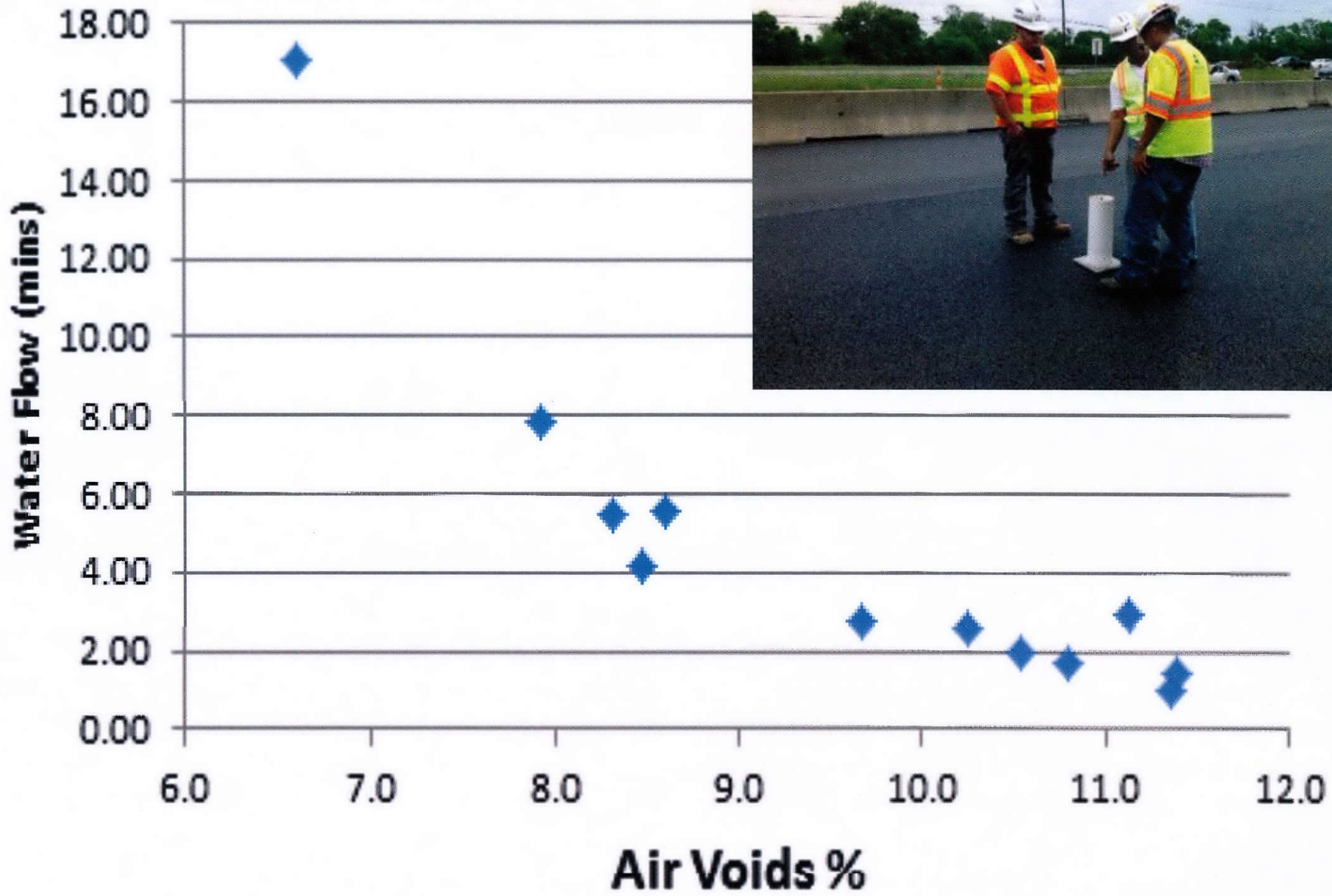



For more information contact:

[T-Scullion@tti.tamu.edu](mailto:T-Scullion@tti.tamu.edu)

[T-Blackmore@tti.tamu.edu](mailto:T-Blackmore@tti.tamu.edu)

[C-estakhri@tti.tamu.edu](mailto:C-estakhri@tti.tamu.edu)











**Texas A&M Transportation Institute**  
**College Station, TX 77843-3135**  
**979-845-1734**  
**<http://tti.tamu.edu>**